

Thyristor/Diode and Thyristor/Thyristor, 250A (MAGN-A-PAK Power Modules)



MAGN-A-PAK

FEATURES

- High voltage
- Electrically isolated by DBC ceramic (Al_2O_3)
- 3500 V_{RMS} isolating voltage
- Industrial standard package
- High surge capability
- Modules uses high voltage power thyristor/diodes in two basic configurations
- Simple mounting
- UL approved file E320098
- Compliant to RoHS
- Designed and qualified for multiple level

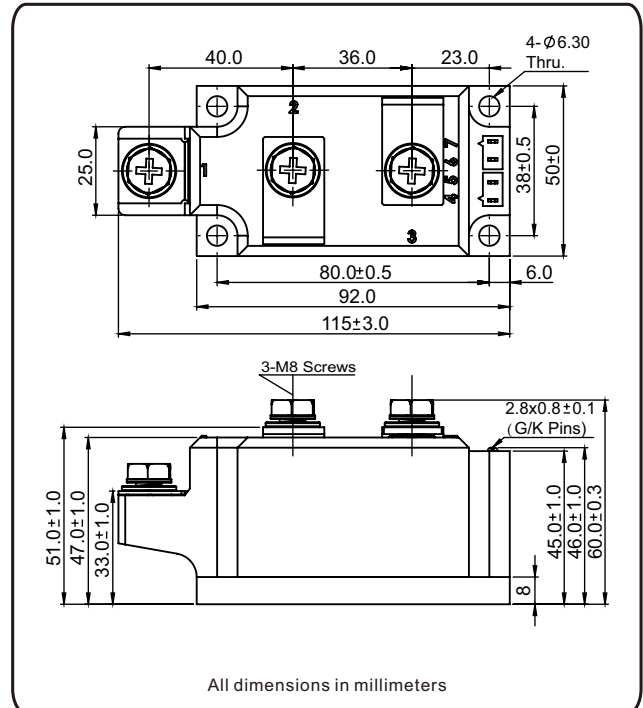

APPLICATIONS

- DC motor control and drives
- Battery charges
- Welders
- Power converters
- Lighting control
- Heat and temperature control
- Ups

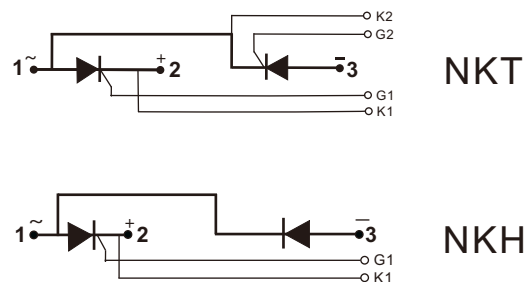

PRODUCT SUMMARY	
$I_T(AV)/I_F(AV)$	250 A

MAJOR RATINGS AND CHARACTERISTICS			
SYMBOL	CHARACTERISTICS	VALUE	UNITS
$I_T(AV)/I_F(AV)$	85 °C	250	A
$I_T(RMS)$	85 °C	393	A
I_{TSM}/I_{FSM}	50 Hz	8500	
	60 Hz	8925	
I^2t	50 Hz	361	kA ² s
	60 Hz	329	
$I^2t_{\sqrt{t}}$		3612	kA ² /√s
V_{DRM}/V_{RRM}	Range	400 to 1600	V
T_J	Range	-40 to 125	°C

ELECTRICAL SPECIFICATIONS

VOLTAGE RATINGS				
TYPE NUMBER	VOLTAGE CODE	V_{RRM}/V_{DRM} , MAXIMUM REPETITIVE PEAK REVERSE VOLTAGE V	V_{RSM}/V_{DSM} , MAXIMUM NON-REPETITIVE PEAK REVERSE VOLTAGE V	I_{RRM}/I_{DRM} AT 125 °C mA
NKT250/..T NKH250/..T	04	400	500	30
	08	800	900	
	10	1000	1100	
	12	1200	1300	
	14	1400	1500	
	16	1600	1700	

FORWARD CONDUCTION							
PARAMETER	SYMBOL	TEST CONDITIONS		VALUES	UNITS		
Maximum average on-state current at case temperature	$I_{T(AV)}$ $I_{F(AV)}$	180° conduction, half sine wave ,50Hz		250	A		
				85	°C		
Maximum RMS on-state current	$I_{T(RMS)}$	180° conduction, half sine wave ,50Hz , $T_C = 85^\circ\text{C}$		393	A		
Maximum peak, one-cycle, on-state non-repetitive surge current	I_{TSM} I_{FSM}	t = 10 ms	No voltage reapplied	Sine half wave, initial $T_J = T_J$ maximum	8500		
		t = 8.3 ms			8925		
Maximum I^2t for fusing	I^2t	t = 10 ms			100% V_{RRM} reapplied		361
		t = 8.3 ms					329
		t = 10 ms	253				
		t = 8.3 ms	230				
Maximum $I^2\sqrt{t}$ for fusing	$I^2\sqrt{t}$	t = 0.1 ms to 10 ms, no voltage reapplied		3612	$\text{kA}^2\sqrt{\text{s}}$		
Maximum on-state voltage drop	V_{TM}	$I_{TM} = 750\text{A}$, $T_J = 25^\circ\text{C}$, 180° conduction		1.7	V		
Maximum forward voltage drop	V_{FM}	$I_{FM} = 750\text{A}$, $T_J = 25^\circ\text{C}$, 180° conduction		1.4			
Maximum holding current	I_H	Anode supply = 12 V initial $I_T = 1\text{A}$, $T_J = 25^\circ\text{C}$		200	mA		
Maximum latching current	I_L	Anode supply = 12 V resistive load = 1 Ω Gate pulse: 10 V, 100 μs , $T_J = 25^\circ\text{C}$		400			

SWITCHING					
PARAMETER	SYMBOL	TEST CONDITIONS		VALUES	UNITS
Typical delay time	t_d	$T_J = 25^\circ\text{C}$, gate current = 1A, $dI_g/dt = 1\text{A}/\mu\text{s}$ $V_d = 0.67 V_{DRM}$		1.0	μs
Typical rise time	t_r			2.0	
Typical turn-off time	t_q	$I_{TM} = 300\text{A}$, $dI/dt = 15\text{A}/\mu\text{s}$, $T_J = T_J$ maximum $V_R = 50\text{V}$, $dV/dt = 20\text{V}/dt$, gate 0V, 100 Ω		50 to 150	

BLOCKING					
PARAMETER	SYMBOL	TEST CONDITIONS		VALUES	UNITS
Maximum peak reverse and off-state leakage current	I_{RRM} , I_{DRM}	$T_J = 125^\circ\text{C}$		30	mA
RMS isolation Voltage	V_{ISO}	50 Hz, circuit to base, all terminals shorted, 25°C, 1s		3500	V
Critical rate of rise of off-state voltage	dV/dt	$T_J = T_J$ maximum, exponential to 67% rated V_{DRM}		1000	$\text{V}/\mu\text{s}$

TRIGGERING					
PARAMETER	SYMBOL	TEST CONDITIONS		VALUES	UNITS
Maximum peak gate power	P_{GM}	$t_p \leq 5 \text{ ms}, T_J = T_J \text{ maximum}$		10	W
Maximum average gate power	$P_{G(AV)}$	$f = 50 \text{ Hz}, T_J = T_J \text{ maximum}$		2	
Maximum peak gate current	I_{GM}	$t_p \leq 5 \text{ ms}, T_J = T_J \text{ maximum}$		3	A
Maximum peak negative gate voltage	$-V_{GM}$			5	V
Maximum required DC gate voltage to trigger	V_{GT}	$T_J = 25 \text{ }^\circ\text{C}$	Anode supply = 12 V, resistive load; $R_a = 1\Omega$	2	
Maximum required DC gate current to trigger	I_{GT}			200	
Maximum gate voltage that will not trigger	V_{GD}	$T_J = T_J \text{ maximum}, 67\% V_{DRM} \text{ applied}$		0.25	V
Maximum gate current that will not trigger	I_{GD}			10	mA
Maximum rate of rise of turned-on current	di/dt	$T_J = T_J \text{ maximum}, I_{TM} = 400\text{A}$ rated V_{DRM} applied		500	A/ μs

THERMAL AND MECHANICAL SPECIFICATIONS					
PARAMETER	SYMBOL	TEST CONDITIONS		VALUES	UNITS
junction operating and storage temperature range	T_J, T_{stg}			- 40 to 125	$^\circ\text{C}$
Maximum thermal resistance, junction to case per junction	R_{thJC}	DC operation		0.125	$^\circ\text{C/W}$
Typical thermal resistance, case to heatsink per module	R_{thCS}	Mounting surface, smooth, flat and greased		0.02	
Mounting torque $\pm 10\%$	MAP to heatsink, M6 busbar to MAP, M8	A mounting compound is recommended and the torque should be rechecked after a period of about 3 hours to allow for the spread of the compound.		4 to 6	N.m
Approximate weight				900	g
				31.7	oz.
Case style				MAGN-A-PAK	

ORDERING INFORMATION TABLE

Device code	NKT	250	/	16	T
	①	②		③	④

- 1** - Module type: NKT for (Thyristor + Thyristor) module
NKH for (Thyristor + Diode) module
- 2** - Current rating: $I_{T(AV)} / I_{F(AV)}$
- 3** - Voltage code x 100 = V_{RRM}
- 4** - "T" for terminal type

Nell High Power Products

Fig.1 On-state current vs. voltage characteristics

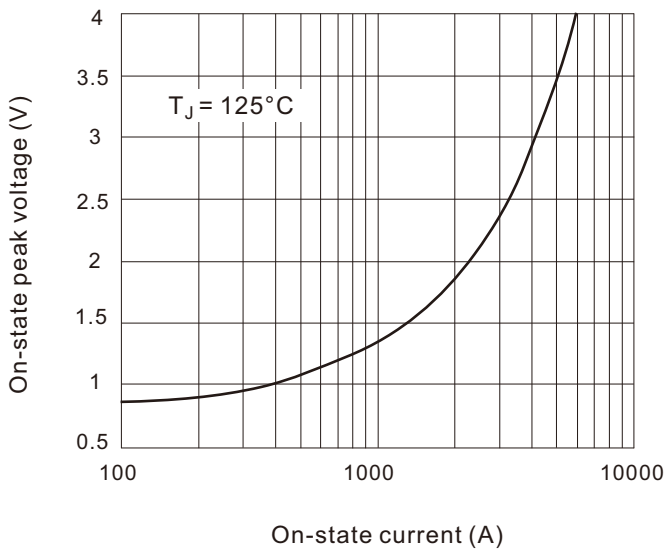

Fig.2 Transient thermal impedance(junction-case)

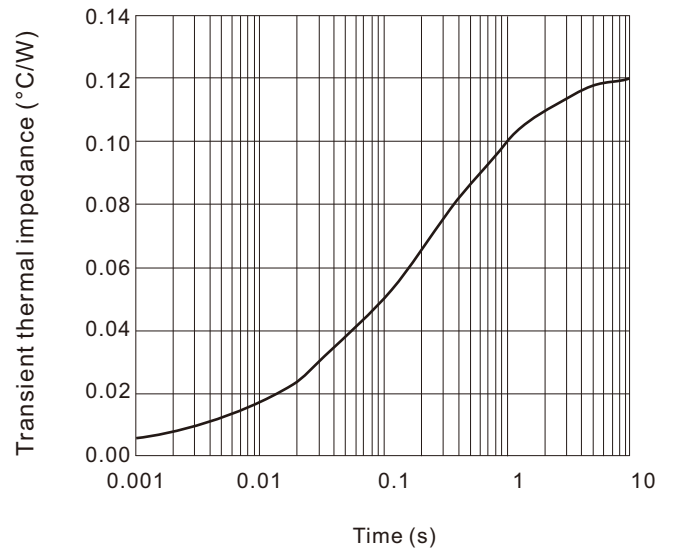

Fig.3 Power consumption vs. average current

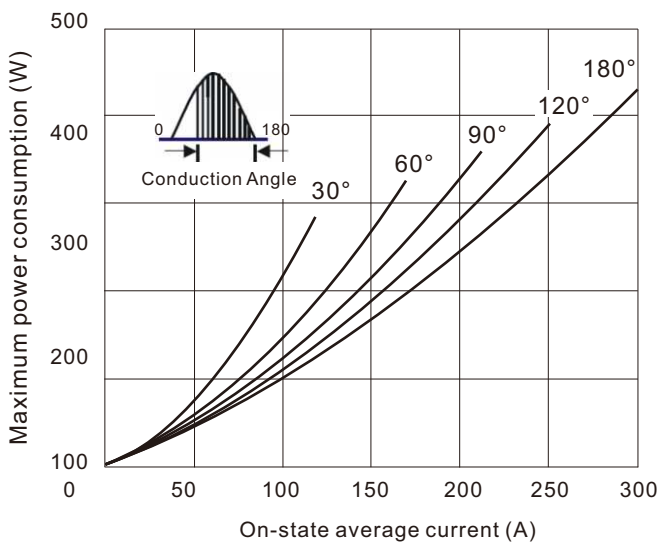

Fig.4 Case temperature vs. on-state average current

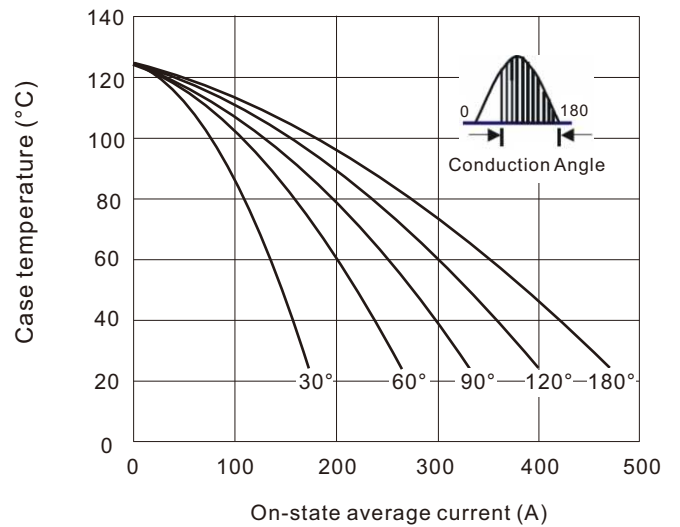

Fig.5 On-state surge current vs cycles

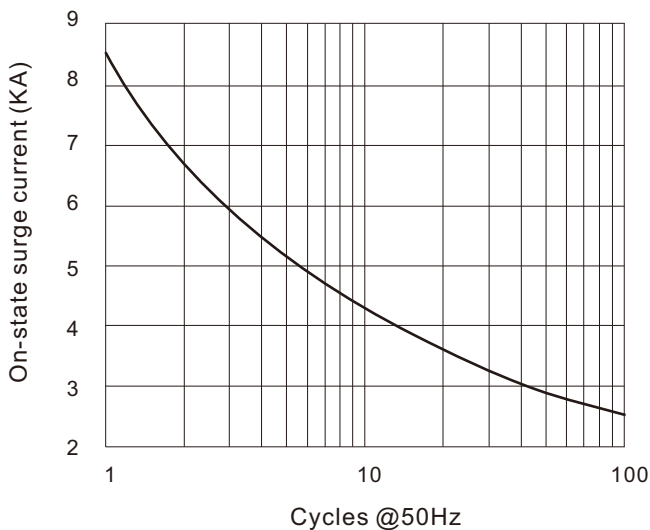

Fig.6 I^2t characteristics

