

## PRECISION MICROPOWER SHUNT VOLTAGE REFERENCE

 Check for Samples: [TL4050-Q1](#)

### FEATURES

- Qualified for Automotive Applications
- Fixed Output Voltages of 2.048 V, 2.5 V, 4.096 V, 5 V
- Tight Output Tolerances and Low Temperature Coefficient
  - Max 0.1%, 50 ppm/°C – A Grade
  - Max 0.2%, 50 ppm/°C – B Grade
  - Max 0.5%, 50 ppm/°C – C Grade
- Low Output Noise: 41  $\mu\text{V}_{\text{RMS}}$  Typ
- Wide Operating Current Range: 60  $\mu\text{A}$  Typ to 15 mA
- Stable With All Capacitive Loads; No Output

### Capacitor Required

- Available in Extended Temperature Range: –40°C to 125°C

### APPLICATIONS

- Data-Acquisition Systems
- Power Supplies and Power-Supply Monitors
- Instrumentation and Test Equipment
- Process Controls
- Precision Audio
- Automotive Electronics
- Energy Management
- Battery-Powered Equipment

DBZ (SOT-23-3) PACKAGE  
(TOP VIEW)

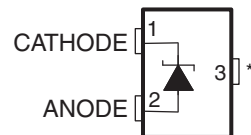

\*Pin 3 is attached to Substrate and must be connected to ANODE or left open.

DCK (SC-70) PACKAGE  
(TOP VIEW)

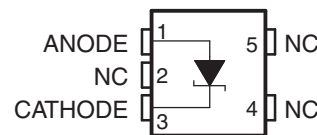

NC – No internal connection

### DESCRIPTION

The TL4050-Q1 family of shunt voltage references are versatile easy-to-use references suitable for a wide array of applications. The two-terminal fixed-output device requires no external capacitors for operation and is stable with all capacitive loads. Additionally, the reference offers low dynamic impedance, low noise, and low temperature coefficient to ensure a stable output voltage over a wide range of operating currents and temperatures.

The TL4050-Q1 is available in three initial tolerances, ranging from 0.1% (maximum) for the A grade to 0.5% (maximum) for the C grade. Thus, a great deal of flexibility is available to designers in choosing the best cost-to-performance ratio for their applications. Packaged in the space-saving SOT-23-3 and SC-70 packages and requiring a minimum current of 45  $\mu\text{A}$  (typical), the TL4050-Q1 also is ideal for portable applications.

The TL4050x-Q1 characterization is for operation over an ambient temperature range of –40°C to 125°C.

### PACKAGE AND ORDERING INFORMATION

For the most-current package and ordering information, see the Package Option Addendum at the end of this document, or see the TI Web site at [www.ti.com](http://www.ti.com).

Package drawings, thermal data, and symbolization are available at [www.ti.com/packaging](http://www.ti.com/packaging).



Please be aware that an important notice concerning availability, standard warranty, and use in critical applications of Texas Instruments semiconductor products and disclaimers thereto appears at the end of this data sheet.

**FUNCTIONAL BLOCK DIAGRAM**

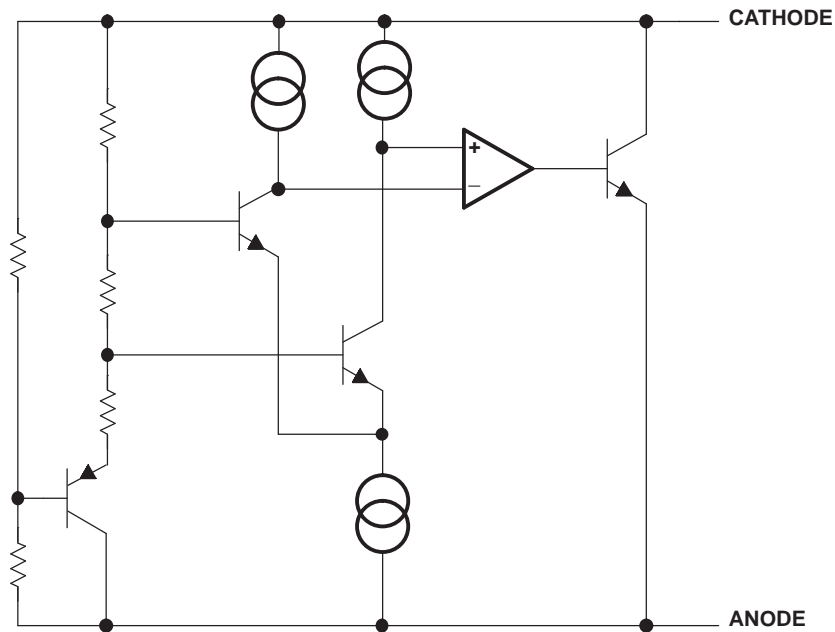

**ABSOLUTE MAXIMUM RATINGS<sup>(1)</sup>**

over free-air temperature range (unless otherwise noted)

		MIN	MAX	UNIT
$I_Z$	Continuous cathode current	-10	20	mA
$T_J$	Operating virtual junction temperature		150	°C
$T_{stg}$	Storage temperature range	-65	150	°C

(1) Stresses beyond those listed under *Absolute Maximum Ratings* may cause permanent damage to the device. These are stress ratings only, and functional operation of the device at these or any other conditions beyond those indicated under *Recommended Operating Conditions* is not implied. Exposure to absolute-maximum-rated conditions for extended periods may affect device reliability.

## THERMAL INFORMATION

THERMAL METRIC <sup>(1)</sup>	TL4050-Q1		UNIT
	DBZ	DCK	
	3 PINS	5 PINS	
$\theta_{JA}$ Junction-to-ambient thermal resistance <sup>(2)</sup>	331.1	289.9	°C/W
$\theta_{JcTop}$ Junction-to-case (top) thermal resistance <sup>(3)</sup>	107.5	56.4	°C/W
$\theta_{JB}$ Junction-to-board thermal resistance <sup>(4)</sup>	63.4	93	°C/W
$\psi_{JT}$ Junction-to-top characterization parameter <sup>(5)</sup>	4.9	0.7	°C/W
$\psi_{JB}$ Junction-to-board characterization parameter <sup>(6)</sup>	61.7	91.4	°C/W
$\theta_{JcBot}$ Junction-to-case (bottom) thermal resistance <sup>(7)</sup>	N/A	N/A	°C/W

- (1) For more information about traditional and new thermal metrics, see the *IC Package Thermal Metrics* application report, [SPRA953](#).
- (2) The junction-to-ambient thermal resistance under natural convection is obtained in a simulation on a JEDEC-standard, high-K board, as specified in JESD51-7, in an environment described in JESD51-2a.
- (3) The junction-to-case (top) thermal resistance is obtained by simulating a cold plate test on the package top. No specific JEDEC-standard test exists, but a close description can be found in the ANSI SEMI standard G30-88.
- (4) The junction-to-board thermal resistance is obtained by simulating in an environment with a ring cold plate fixture to control the PCB temperature, as described in JESD51-8.
- (5) The junction-to-top characterization parameter,  $\psi_{JT}$ , estimates the junction temperature of a device in a real system and is extracted from the simulation data for obtaining  $\theta_{JA}$ , using a procedure described in JESD51-2a (sections 6 and 7).
- (6) The junction-to-board characterization parameter,  $\psi_{JB}$ , estimates the junction temperature of a device in a real system and is extracted from the simulation data for obtaining  $\theta_{JA}$ , using a procedure described in JESD51-2a (sections 6 and 7).
- (7) The junction-to-case (bottom) thermal resistance is obtained by simulating a cold plate test on the exposed (power) pad. No specific JEDEC standard test exists, but a close description can be found in the ANSI SEMI standard G30-88.

## RECOMMENDED OPERATING CONDITIONS

		MIN	MAX	UNIT	
$I_Z$	Cathode current	(1)	15	mA	
$T_A$	Free-air temperature	I temperature	-40	85	°C
		Q temperature	-40	125	

- (1) See parametric tables

### TL4050x20-Q1 ELECTRICAL CHARACTERISTICS

at extended temperature range, full range  $T_A = -40^{\circ}\text{C}$  to  $125^{\circ}\text{C}$  (unless otherwise noted)

PARAMETER	TEST CONDITIONS	$T_A$	TL4050A20-Q1			TL4050B20-Q1			TL4050C20-Q1			UNIT
			MIN	TYP	MAX	MIN	TYP	MAX	MIN	TYP	MAX	
$V_Z$	Reverse breakdown voltage $I_Z = 100 \mu\text{A}$	$25^{\circ}\text{C}$	2.048			2.048			2.048			V
$\Delta V_Z$	Reverse breakdown voltage tolerance $I_Z = 100 \mu\text{A}$	$25^{\circ}\text{C}$	-2.048	2.048		-4.096	4.096		-10.24	10.24		mV
		Full range	-12.288	12.288		-14.7456	14.7456		-17.2032	17.2032		
$I_{Z,\text{min}}$	Minimum cathode current	$25^{\circ}\text{C}$	41		60		41		60		$\mu\text{A}$	
		Full range			65				65			
$\alpha_{VZ}$	Average temperature coefficient of reverse breakdown voltage $I_Z = 10 \text{ mA}$	$25^{\circ}\text{C}$	$\pm 20$			$\pm 20$			$\pm 20$			ppm/ $^{\circ}\text{C}$
		$25^{\circ}\text{C}$	$\pm 15$			$\pm 15$			$\pm 15$			
		$25^{\circ}\text{C}$	$\pm 15$			$\pm 15$			$\pm 15$			
		Full range	$\pm 50$			$\pm 50$			$\pm 50$			
$\frac{\Delta V_Z}{\Delta I_Z}$	Reverse breakdown voltage change with cathode current change $I_{Z,\text{min}} < I_Z < 1 \text{ mA}$	$25^{\circ}\text{C}$	0.3	0.8		0.3	0.8		0.3	0.8		mV
		Full range			1.2				1.2			
	$1 \text{ mA} < I_Z < 15 \text{ mA}$	$25^{\circ}\text{C}$	2.3		6		2.3		6			
		Full range			8				8			
$Z_Z$	Reverse dynamic impedance $I_Z = 1 \text{ mA}$ , $f = 120 \text{ Hz}$ , $I_{AC} = 0.1 I_Z$	$25^{\circ}\text{C}$	0.3			0.3			0.3			$\Omega$
$e_N$	Wideband noise $I_Z = 100 \mu\text{A}$ , $10 \text{ Hz} \leq f \leq 10 \text{ kHz}$	$25^{\circ}\text{C}$	34			34			34			$\mu\text{V}_{\text{RMS}}$
	Long-term stability of reverse breakdown voltage $t = 1000 \text{ h}$ , $T_A = 25^{\circ}\text{C} \pm 0.1^{\circ}\text{C}$ , $I_Z = 100 \mu\text{A}$		120			120			120			ppm
$V_{\text{HYST}}$	Thermal hysteresis <sup>(1)</sup> $\Delta T_A = -40^{\circ}\text{C}$ to $125^{\circ}\text{C}$		0.7			0.7			0.7			mV

(1) Thermal hysteresis is defined as  $V_{Z,25^{\circ}\text{C}}$  (after cycling to  $-40^{\circ}\text{C}$ ) –  $V_{Z,25^{\circ}\text{C}}$  (after cycling to  $125^{\circ}\text{C}$ ).

**TL4050x25-Q1 ELECTRICAL CHARACTERISTICS**

 at extended temperature range, full range  $T_A = -40^{\circ}\text{C}$  to  $125^{\circ}\text{C}$  (unless otherwise noted)

PARAMETER	TEST CONDITIONS	$T_A$	TL4050B25-Q1			UNIT
			MIN	TYP	MAX	
$V_Z$	Reverse breakdown voltage	$I_Z = 100\ \mu\text{A}$		2.5		V
$\Delta V_Z$	Reverse breakdown voltage tolerance	$I_Z = 100\ \mu\text{A}$			5	mV
		Full range	-5		18	
$I_{Z,\text{min}}$	Minimum cathode current	$I_Z = 100\ \mu\text{A}$		41	60	$\mu\text{A}$
		Full range	-18		65	
$\alpha_{VZ}$	Average temperature coefficient of reverse breakdown voltage	$I_Z = 10\ \text{mA}$	$25^{\circ}\text{C}$	$\pm 20$		ppm/ $^{\circ}\text{C}$
		$I_Z = 1\ \text{mA}$	$25^{\circ}\text{C}$	$\pm 15$		
		$I_Z = 100\ \mu\text{A}$	$25^{\circ}\text{C}$	$\pm 15$		
		Full range			$\pm 50$	
$\frac{\Delta V_Z}{\Delta I_Z}$	Reverse breakdown voltage change with cathode current change	$I_{Z,\text{min}} < I_Z < 1\ \text{mA}$	$25^{\circ}\text{C}$	0.3	0.8	mV
			Full range			
		$1\ \text{mA} < I_Z < 15\ \text{mA}$	$25^{\circ}\text{C}$	2.3	6	
			Full range			
$Z_Z$	Reverse dynamic impedance	$I_Z = 1\ \text{mA}$ , $f = 120\ \text{Hz}$ , $I_{AC} = 0.1\ I_Z$	$25^{\circ}\text{C}$	0.3		$\Omega$
$e_N$	Wideband noise	$I_Z = 100\ \mu\text{A}$ , $10\ \text{Hz} \leq f \leq 10\ \text{kHz}$	$25^{\circ}\text{C}$	41		$\mu\text{V}_{\text{RMS}}$
	Long-term stability of reverse breakdown voltage	$t = 1000\ \text{h}$ , $T_A = 25^{\circ}\text{C} \pm 0.1^{\circ}\text{C}$ , $I_Z = 100\ \mu\text{A}$		120		ppm
$V_{\text{HYST}}$	Thermal hysteresis <sup>(1)</sup>	$\Delta T_A = -40^{\circ}\text{C}$ to $125^{\circ}\text{C}$		0.7		mV

 (1) Thermal hysteresis is defined as  $V_{Z,25^{\circ}\text{C}}$  (after cycling to  $-40^{\circ}\text{C}$ ) –  $V_{Z,25^{\circ}\text{C}}$  (after cycling to  $125^{\circ}\text{C}$ ).

### TL4050x41-Q1 ELECTRICAL CHARACTERISTICS

at extended temperature range, full range  $T_A = -40^{\circ}\text{C}$  to  $125^{\circ}\text{C}$  (unless otherwise noted)

PARAMETER	TEST CONDITIONS	$T_A$	TL4050B41-Q1			UNIT
			MIN	TYP	MAX	
$V_Z$	Reverse breakdown voltage	$I_Z = 100\ \mu\text{A}$		4.096		V
$\Delta V_Z$	Reverse breakdown voltage tolerance	$I_Z = 100\ \mu\text{A}$	25°C	-8.2	8.2	mV
			Full range	-29	29	
$I_{Z,\text{min}}$	Minimum cathode current		25°C	52	68	$\mu\text{A}$
			Full range		78	
$\alpha_{VZ}$	Average temperature coefficient of reverse breakdown voltage	$I_Z = 10\ \text{mA}$	25°C	$\pm 30$		ppm/°C
		$I_Z = 1\ \text{mA}$	25°C	$\pm 20$		
		$I_Z = 100\ \mu\text{A}$	25°C	$\pm 20$		
			Full range		$\pm 50$	
$\frac{\Delta V_Z}{\Delta I_Z}$	Reverse breakdown voltage change with cathode current change	$I_{Z,\text{min}} < I_Z < 1\ \text{mA}$	25°C	0.2	0.9	mV
			Full range			
		$1\ \text{mA} < I_Z < 15\ \text{mA}$	25°C	2	7	
			Full range			
$Z_Z$	Reverse dynamic impedance	$I_Z = 1\ \text{mA}$ , $f = 120\ \text{Hz}$ , $I_{AC} = 0.1\ I_Z$	25°C	0.5		$\Omega$
$e_N$	Wideband noise	$I_Z = 100\ \mu\text{A}$ , $10\ \text{Hz} \leq f \leq 10\ \text{kHz}$	25°C	93		$\mu\text{V}_{\text{RMS}}$
	Long-term stability of reverse breakdown voltage	$t = 1000\ \text{h}$ , $T_A = 25^{\circ}\text{C} \pm 0.1^{\circ}\text{C}$ , $I_Z = 100\ \mu\text{A}$		120		ppm
$V_{\text{HYST}}$	Thermal hysteresis <sup>(1)</sup>	$\Delta T_A = -40^{\circ}\text{C}$ to $125^{\circ}\text{C}$		1.148		mV

(1) Thermal hysteresis is defined as  $V_{Z,25^{\circ}\text{C}}$  (after cycling to  $-40^{\circ}\text{C}$ ) –  $V_{Z,25^{\circ}\text{C}}$  (after cycling to  $125^{\circ}\text{C}$ ).

## TL4050x50-Q1 ELECTRICAL CHARACTERISTICS

 at extended temperature range, full range  $T_A = -40^{\circ}\text{C}$  to  $125^{\circ}\text{C}$  (unless otherwise noted)

PARAMETER	TEST CONDITIONS	$T_A$	TL4050A50-Q1			TL4050B50-Q1			TL4050C50-Q1			UNIT
			MIN	TYP	MAX	MIN	TYP	MAX	MIN	TYP	MAX	
$V_Z$	Reverse breakdown voltage	$I_Z = 100\ \mu\text{A}$	25°C			5			5			V
$\Delta V_Z$	Reverse breakdown voltage tolerance	$I_Z = 100\ \mu\text{A}$	25°C			-5			5			mV
			Full range			-30			30			
$I_{Z,\text{min}}$	Minimum cathode current		25°C			56			74			$\mu\text{A}$
			Full range			90			90			
$\alpha_{VZ}$	Average temperature coefficient of reverse breakdown voltage	$I_Z = 10\ \text{mA}$	25°C			$\pm 30$			$\pm 30$			ppm/°C
		$I_Z = 1\ \text{mA}$	25°C			$\pm 20$			$\pm 20$			
		$I_Z = 100\ \mu\text{A}$	25°C			$\pm 20$			$\pm 20$			
			Full range			$\pm 50$			$\pm 50$			
$\frac{\Delta V_Z}{\Delta I_Z}$	Reverse breakdown voltage change with cathode current change	$I_{Z,\text{min}} < I_Z < 1\ \text{mA}$	25°C			0.2			1			mV
			Full range			1.4			1.4			
		$1\ \text{mA} < I_Z < 15\ \text{mA}$	25°C			2			8			
			Full range			12			12			
$Z_Z$	Reverse dynamic impedance	$I_Z = 1\ \text{mA}$ , $f = 120\ \text{Hz}$ , $I_{AC} = 0.1 I_Z$	25°C			0.5			0.5			$\Omega$
$e_N$	Wideband noise	$I_Z = 100\ \mu\text{A}$ , $10\ \text{Hz} \leq f \leq 10\ \text{kHz}$	25°C			93			93			$\mu\text{V}_{\text{RMS}}$
	Long-term stability of reverse breakdown voltage	$t = 1000\ \text{h}$ , $T_A = 25^{\circ}\text{C} \pm 0.1^{\circ}\text{C}$ , $I_Z = 100\ \mu\text{A}$				120			120			ppm
$V_{\text{HYST}}$	Thermal hysteresis <sup>(1)</sup>	$\Delta T_A = -40^{\circ}\text{C}$ to $125^{\circ}\text{C}$				1.4			1.4			mV

 (1) Thermal hysteresis is defined as  $V_{Z,25^{\circ}\text{C}}$  (after cycling to  $-40^{\circ}\text{C}$ ) –  $V_{Z,25^{\circ}\text{C}}$  (after cycling to  $125^{\circ}\text{C}$ ).

TYPICAL CHARACTERISTICS

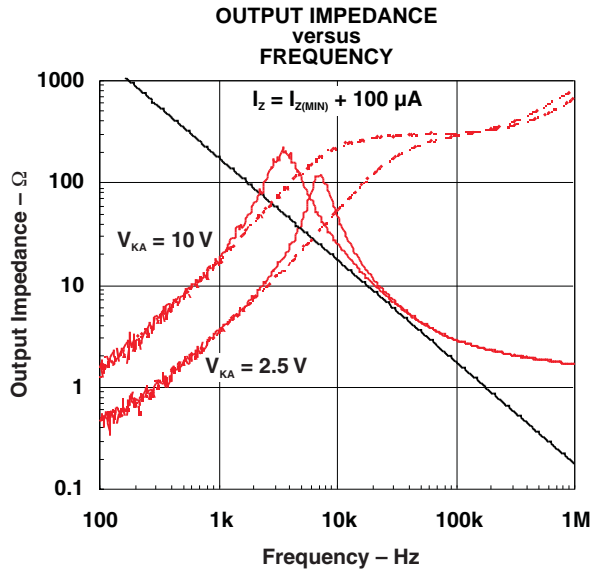

Figure 1.

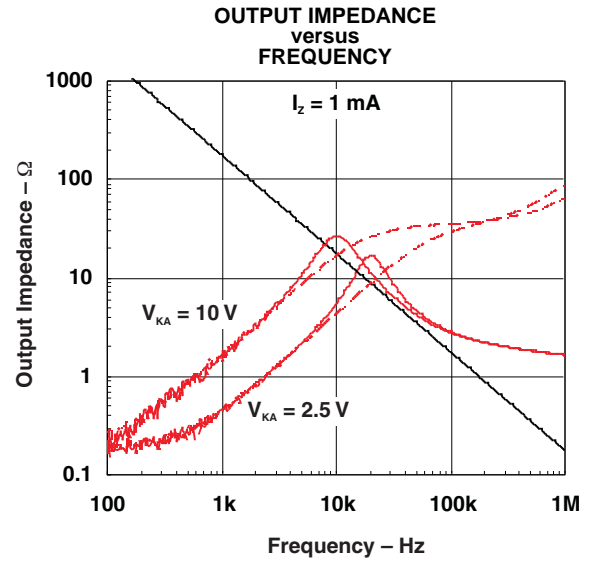

Figure 2.

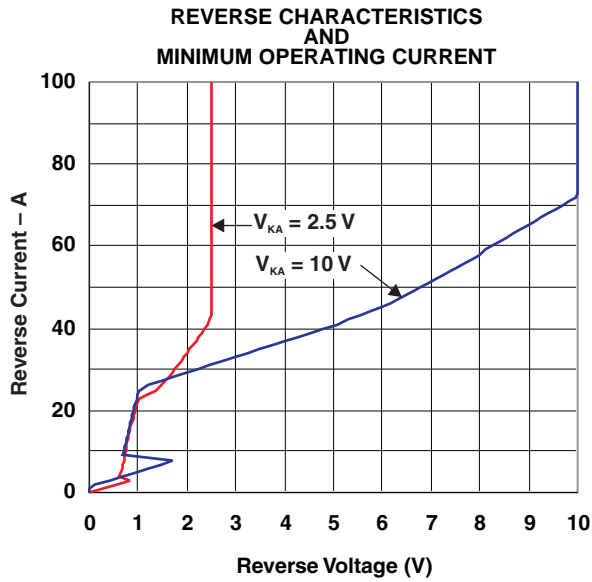

Figure 3.

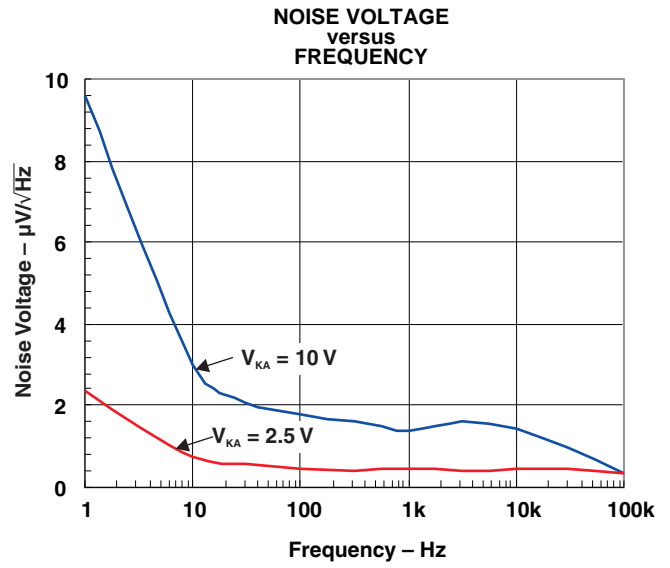

Figure 4.

TYPICAL CHARACTERISTICS (continued)

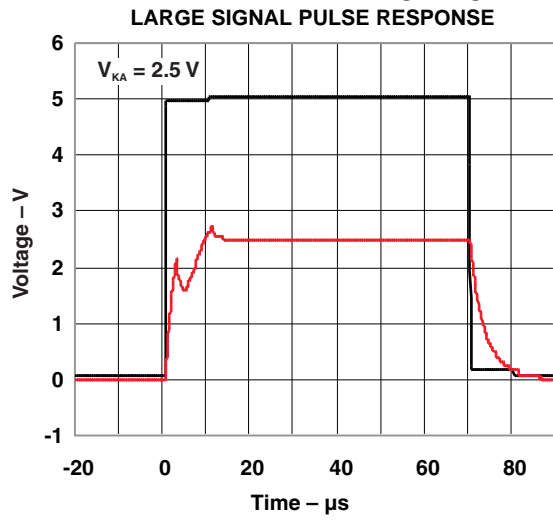

Figure 5.

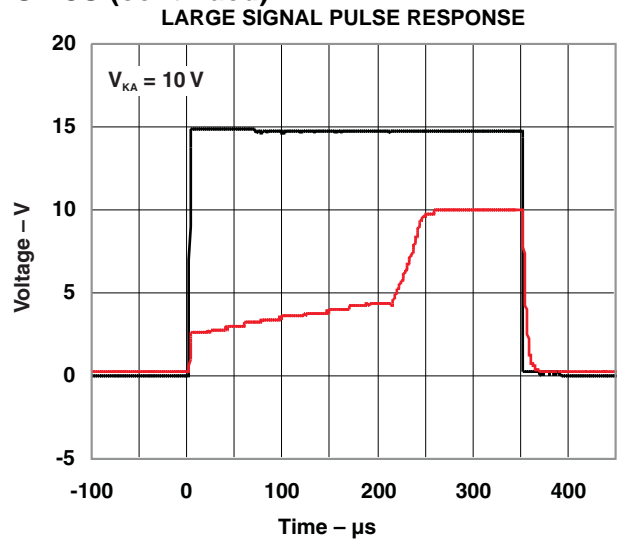
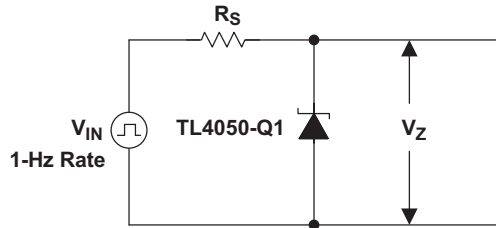

Figure 6.

**APPLICATION INFORMATION**



**Figure 7. Start-Up Test Circuit**

**Output Capacitor**

The TL4050-Q1 does not require an output capacitor across cathode and anode for stability. However, in an application using an output bypass capacitor, the TL4050-Q1 is stable with all capacitive loads.

**SOT-23-3 Pin Connections**

There is a parasitic Schottky diode connected between pins 2 and 3 of the SOT-23-3 packaged device. Thus, pin 3 of the SOT-23-3 package must be left floating or connected to pin 2.

**Use With ADCs or DACs**

The design of the TL4050x41-Q1 is as a cost-effective voltage reference, as required in 12-bit data-acquisition systems. For 12-bit systems operating from 5-V supplies, such as the ADS7842 (see Figure 8), the TL4050x41-Q1 (4.096 V) permits operation with an LSB of 1 mV.

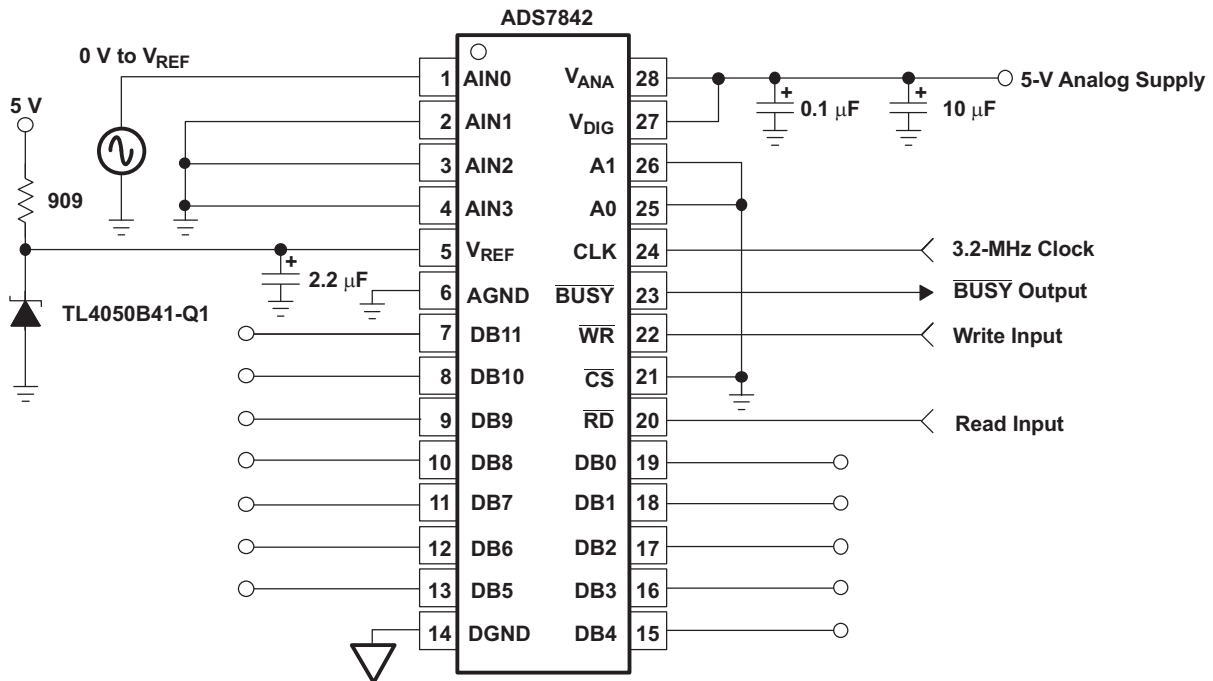

**Figure 8. Data-Acquisition Circuit With TL4050x41-Q1**

## Cathode and Load Currents

In a typical shunt-regulator configuration (see [Figure 9](#)), an external resistor,  $R_S$ , connects between the supply and the cathode of the TL4050-Q1. Proper choice of  $R_S$  is essential, as  $R_S$  sets the total current available to supply the load ( $I_L$ ) and bias the TL4050-Q1 ( $I_Z$ ). In all cases,  $I_Z$  must stay within a specified range for proper operation of the reference. Taking into consideration one extreme in the variation of the load and supply voltage (maximum  $I_L$  and minimum  $V_S$ ),  $R_S$  must be small enough to supply the minimum  $I_Z$  required for operation of the regulator, as given by data-sheet parameters. At the other extreme, maximum  $V_S$  and minimum  $I_L$ ,  $R_S$  must be large enough to limit  $I_Z$  to less than its maximum-rated value of 15 mA.

[Equation 1](#) calculates  $R_S$ :

$$R_S = \frac{(V_S - V_Z)}{(I_L + I_Z)} \quad (1)$$

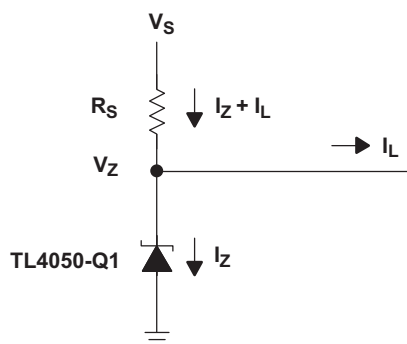

**Figure 9. Shunt Regulator**

**PACKAGING INFORMATION**

Orderable Device	Status (1)	Package Type	Package Drawing	Pins	Package Qty	Eco Plan (2)	Lead/Ball Finish	MSL Peak Temp (3)	Op Temp (°C)	Top-Side Markings (4)	Samples
TL4050A50QDBZRQ1	ACTIVE	SOT-23	DBZ	3	3000	Green (RoHS & no Sb/Br)	CU NIPDAU	Level-1-260C-UNLIM	-40 to 125	TLGU	<a href="#">Samples</a>
TL4050A50QDCKRQ1	ACTIVE	SC70	DCK	5	3000	Green (RoHS & no Sb/Br)	CU NIPDAU	Level-1-260C-UNLIM	-40 to 125	7GU	<a href="#">Samples</a>
TL4050B25QDBZRQ1	ACTIVE	SOT-23	DBZ	3	3000	Green (RoHS & no Sb/Br)	CU NIPDAU	Level-1-260C-UNLIM	-40 to 125	TLHU	<a href="#">Samples</a>
TL4050B25QDCKRQ1	ACTIVE	SC70	DCK	5	3000	Green (RoHS & no Sb/Br)	CU NIPDAU	Level-1-260C-UNLIM	-40 to 125	7HU	<a href="#">Samples</a>
TL4050B41QDBZRQ1	ACTIVE	SOT-23	DBZ	3	3000	Green (RoHS & no Sb/Br)	CU NIPDAU	Level-1-260C-UNLIM	-40 to 125	TMXU	<a href="#">Samples</a>
TL4050B50QDBZRQ1	ACTIVE	SOT-23	DBZ	3	3000	Green (RoHS & no Sb/Br)	CU NIPDAU	Level-1-260C-UNLIM	-40 to 125	TLJU	<a href="#">Samples</a>
TL4050B50QDCKRQ1	ACTIVE	SC70	DCK	5	3000	Green (RoHS & no Sb/Br)	CU NIPDAU	Level-1-260C-UNLIM	-40 to 125	7JU	<a href="#">Samples</a>
TL4050C20QDBZRQ1	ACTIVE	SOT-23	DBZ	3	3000	Green (RoHS & no Sb/Br)	CU NIPDAU	Level-1-260C-UNLIM	-40 to 125	TMYU	<a href="#">Samples</a>
TL4050C50QDBZRQ1	ACTIVE	SOT-23	DBZ	3	3000	Green (RoHS & no Sb/Br)	CU NIPDAU	Level-1-260C-UNLIM	-40 to 125	TKZU	<a href="#">Samples</a>

(1) The marketing status values are defined as follows:

**ACTIVE:** Product device recommended for new designs.

**LIFEBUY:** TI has announced that the device will be discontinued, and a lifetime-buy period is in effect.

**NRND:** Not recommended for new designs. Device is in production to support existing customers, but TI does not recommend using this part in a new design.

**PREVIEW:** Device has been announced but is not in production. Samples may or may not be available.

**OBSOLETE:** TI has discontinued the production of the device.

(2) Eco Plan - The planned eco-friendly classification: Pb-Free (RoHS), Pb-Free (RoHS Exempt), or Green (RoHS & no Sb/Br) - please check <http://www.ti.com/productcontent> for the latest availability information and additional product content details.

**TBD:** The Pb-Free/Green conversion plan has not been defined.

**Pb-Free (RoHS):** TI's terms "Lead-Free" or "Pb-Free" mean semiconductor products that are compatible with the current RoHS requirements for all 6 substances, including the requirement that lead not exceed 0.1% by weight in homogeneous materials. Where designed to be soldered at high temperatures, TI Pb-Free products are suitable for use in specified lead-free processes.

**Pb-Free (RoHS Exempt):** This component has a RoHS exemption for either 1) lead-based flip-chip solder bumps used between the die and package, or 2) lead-based die adhesive used between the die and leadframe. The component is otherwise considered Pb-Free (RoHS compatible) as defined above.

**Green (RoHS & no Sb/Br):** TI defines "Green" to mean Pb-Free (RoHS compatible), and free of Bromine (Br) and Antimony (Sb) based flame retardants (Br or Sb do not exceed 0.1% by weight in homogeneous material)

<sup>(3)</sup> MSL, Peak Temp. -- The Moisture Sensitivity Level rating according to the JEDEC industry standard classifications, and peak solder temperature.

<sup>(4)</sup> Multiple Top-Side Markings will be inside parentheses. Only one Top-Side Marking contained in parentheses and separated by a "~" will appear on a device. If a line is indented then it is a continuation of the previous line and the two combined represent the entire Top-Side Marking for that device.

**Important Information and Disclaimer:** The information provided on this page represents TI's knowledge and belief as of the date that it is provided. TI bases its knowledge and belief on information provided by third parties, and makes no representation or warranty as to the accuracy of such information. Efforts are underway to better integrate information from third parties. TI has taken and continues to take reasonable steps to provide representative and accurate information but may not have conducted destructive testing or chemical analysis on incoming materials and chemicals. TI and TI suppliers consider certain information to be proprietary, and thus CAS numbers and other limited information may not be available for release.

In no event shall TI's liability arising out of such information exceed the total purchase price of the TI part(s) at issue in this document sold by TI to Customer on an annual basis.

**OTHER QUALIFIED VERSIONS OF TL4050A50-Q1, TL4050B25-Q1, TL4050B41-Q1, TL4050B50-Q1, TL4050C50-Q1 :**

- Catalog: [TL4050A50](#), [TL4050B25](#), [TL4050B41](#), [TL4050B50](#), [TL4050C50](#)

NOTE: Qualified Version Definitions:

- Catalog - TI's standard catalog product

## TAPE AND REEL INFORMATION



### QUADRANT ASSIGNMENTS FOR PIN 1 ORIENTATION IN TAPE



\*All dimensions are nominal

Device	Package Type	Package Drawing	Pins	SPQ	Reel Diameter (mm)	Reel Width W1 (mm)	A0 (mm)	B0 (mm)	K0 (mm)	P1 (mm)	W (mm)	Pin1 Quadrant
TL4050A50QDBZRQ1	SOT-23	DBZ	3	3000	179.0	8.4	3.15	2.95	1.22	4.0	8.0	Q3
TL4050A50QDCKRQ1	SC70	DCK	5	3000	179.0	8.4	2.2	2.5	1.2	4.0	8.0	Q3
TL4050B25QDBZRQ1	SOT-23	DBZ	3	3000	179.0	8.4	3.15	2.95	1.22	4.0	8.0	Q3
TL4050B25QDCKRQ1	SC70	DCK	5	3000	179.0	8.4	2.2	2.5	1.2	4.0	8.0	Q3
TL4050B41QDBZRQ1	SOT-23	DBZ	3	3000	179.0	8.4	3.15	2.95	1.22	4.0	8.0	Q3
TL4050B50QDBZRQ1	SOT-23	DBZ	3	3000	179.0	8.4	3.15	2.95	1.22	4.0	8.0	Q3
TL4050B50QDCKRQ1	SC70	DCK	5	3000	179.0	8.4	2.2	2.5	1.2	4.0	8.0	Q3
TL4050C20QDBZRQ1	SOT-23	DBZ	3	3000	179.0	8.4	3.15	2.95	1.22	4.0	8.0	Q3
TL4050C50QDBZRQ1	SOT-23	DBZ	3	3000	179.0	8.4	3.15	2.95	1.22	4.0	8.0	Q3

**TAPE AND REEL BOX DIMENSIONS**

\*All dimensions are nominal

Device	Package Type	Package Drawing	Pins	SPQ	Length (mm)	Width (mm)	Height (mm)
TL4050A50QDBZRQ1	SOT-23	DBZ	3	3000	203.0	203.0	35.0
TL4050A50QDCKRQ1	SC70	DCK	5	3000	203.0	203.0	35.0
TL4050B25QDBZRQ1	SOT-23	DBZ	3	3000	203.0	203.0	35.0
TL4050B25QDCKRQ1	SC70	DCK	5	3000	203.0	203.0	35.0
TL4050B41QDBZRQ1	SOT-23	DBZ	3	3000	203.0	203.0	35.0
TL4050B50QDBZRQ1	SOT-23	DBZ	3	3000	203.0	203.0	35.0
TL4050B50QDCKRQ1	SC70	DCK	5	3000	203.0	203.0	35.0
TL4050C20QDBZRQ1	SOT-23	DBZ	3	3000	203.0	203.0	35.0
TL4050C50QDBZRQ1	SOT-23	DBZ	3	3000	203.0	203.0	35.0

DCK (R-PDSO-G5)

PLASTIC SMALL-OUTLINE PACKAGE



- NOTES:
- A. All linear dimensions are in millimeters.
  - B. This drawing is subject to change without notice.
  - C. Body dimensions do not include mold flash or protrusion. Mold flash and protrusion shall not exceed 0.15 per side.
  - D. Falls within JEDEC MO-203 variation AA.

DCK (R-PDSO-G5)

PLASTIC SMALL OUTLINE



- NOTES:
- All linear dimensions are in millimeters.
  - This drawing is subject to change without notice.
  - Customers should place a note on the circuit board fabrication drawing not to alter the center solder mask defined pad.
  - Publication IPC-7351 is recommended for alternate designs.
  - Laser cutting apertures with trapezoidal walls and also rounding corners will offer better paste release. Customers should contact their board assembly site for stencil design recommendations. Example stencil design based on a 50% volumetric metal load solder paste. Refer to IPC-7525 for other stencil recommendations.

DBZ (R-PDSO-G3)

PLASTIC SMALL-OUTLINE

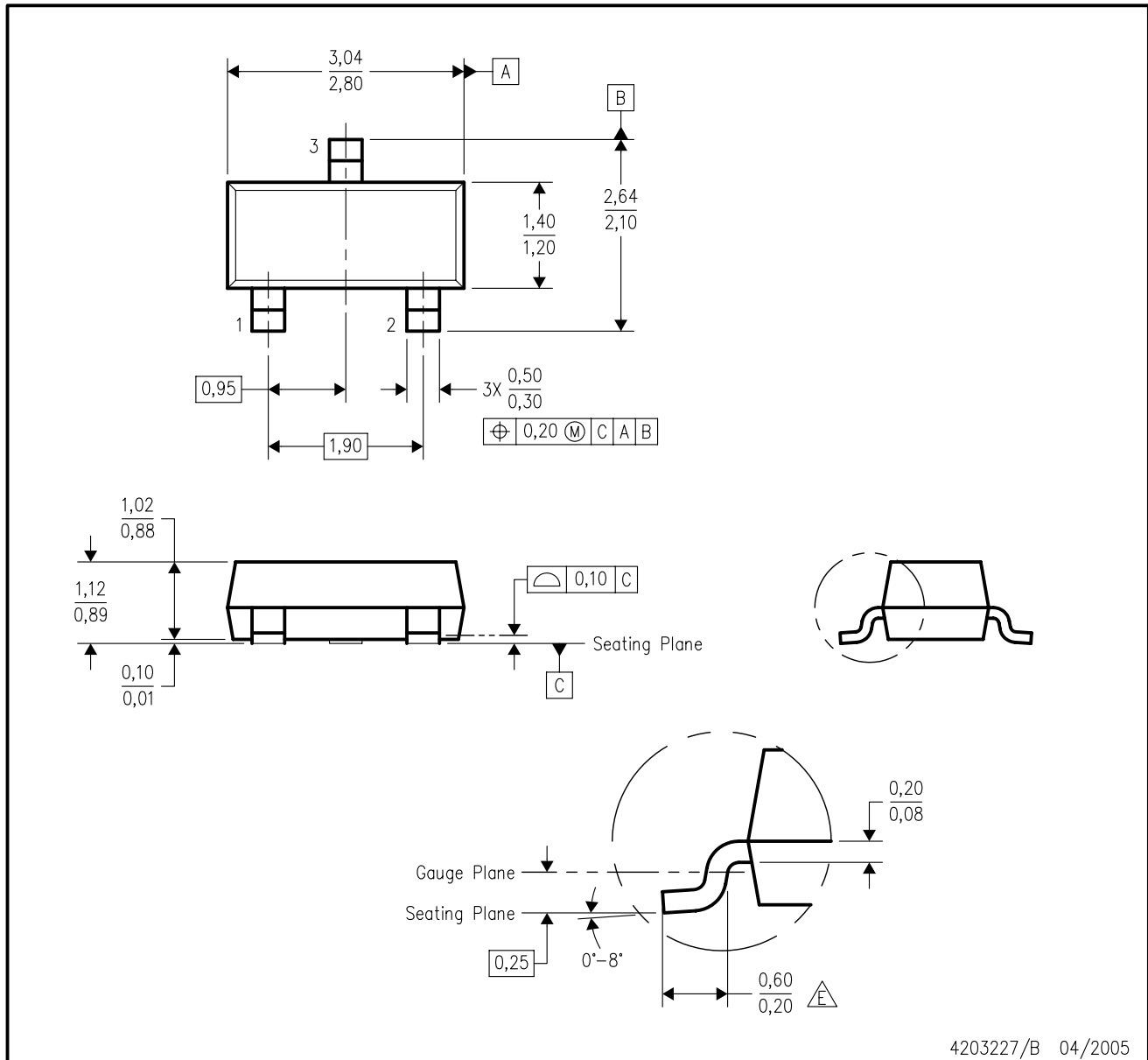

- NOTES:
- A. All linear dimensions are in millimeters. Dimensioning and tolerancing per ASME Y14.5M-1994.
  - B. This drawing is subject to change without notice.
  - C. Lead dimensions are inclusive of plating.
  - D. Body dimensions are exclusive of mold flash and protrusion. Mold flash and protrusion not to exceed 0.25 per side.
  - $\triangle E$  Falls within JEDEC TO-236 variation AB, except minimum foot length.

DBZ (R-PDSO-G3)

PLASTIC SMALL OUTLINE

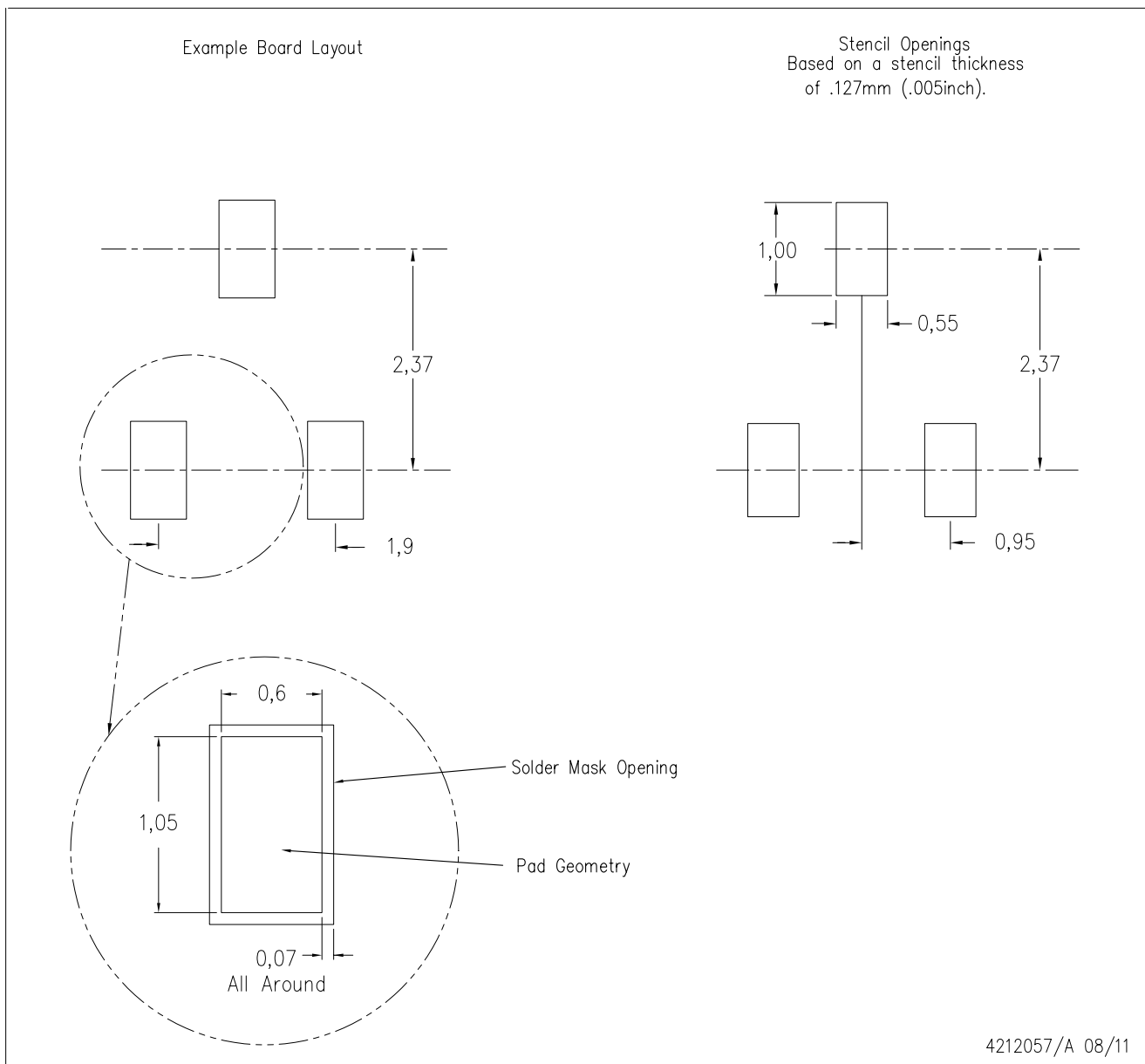

- NOTES:
- A. All linear dimensions are in millimeters.
  - B. This drawing is subject to change without notice.
  - C. Customers should place a note on the circuit board fabrication drawing not to alter the center solder mask defined pad.
  - D. Publication IPC-7351 is recommended for alternate designs.
  - E. Laser cutting apertures with trapezoidal walls and also rounding corners will offer better paste release. Customers should contact their board assembly site for stencil design recommendations. Example stencil design based on a 50% volumetric metal load solder paste. Refer to IPC-7525 for other stencil recommendations.

## IMPORTANT NOTICE

Texas Instruments Incorporated and its subsidiaries (TI) reserve the right to make corrections, enhancements, improvements and other changes to its semiconductor products and services per JESD46, latest issue, and to discontinue any product or service per JESD48, latest issue. Buyers should obtain the latest relevant information before placing orders and should verify that such information is current and complete. All semiconductor products (also referred to herein as "components") are sold subject to TI's terms and conditions of sale supplied at the time of order acknowledgment.

TI warrants performance of its components to the specifications applicable at the time of sale, in accordance with the warranty in TI's terms and conditions of sale of semiconductor products. Testing and other quality control techniques are used to the extent TI deems necessary to support this warranty. Except where mandated by applicable law, testing of all parameters of each component is not necessarily performed.

TI assumes no liability for applications assistance or the design of Buyers' products. Buyers are responsible for their products and applications using TI components. To minimize the risks associated with Buyers' products and applications, Buyers should provide adequate design and operating safeguards.

TI does not warrant or represent that any license, either express or implied, is granted under any patent right, copyright, mask work right, or other intellectual property right relating to any combination, machine, or process in which TI components or services are used. Information published by TI regarding third-party products or services does not constitute a license to use such products or services or a warranty or endorsement thereof. Use of such information may require a license from a third party under the patents or other intellectual property of the third party, or a license from TI under the patents or other intellectual property of TI.

Reproduction of significant portions of TI information in TI data books or data sheets is permissible only if reproduction is without alteration and is accompanied by all associated warranties, conditions, limitations, and notices. TI is not responsible or liable for such altered documentation. Information of third parties may be subject to additional restrictions.

Resale of TI components or services with statements different from or beyond the parameters stated by TI for that component or service voids all express and any implied warranties for the associated TI component or service and is an unfair and deceptive business practice. TI is not responsible or liable for any such statements.

Buyer acknowledges and agrees that it is solely responsible for compliance with all legal, regulatory and safety-related requirements concerning its products, and any use of TI components in its applications, notwithstanding any applications-related information or support that may be provided by TI. Buyer represents and agrees that it has all the necessary expertise to create and implement safeguards which anticipate dangerous consequences of failures, monitor failures and their consequences, lessen the likelihood of failures that might cause harm and take appropriate remedial actions. Buyer will fully indemnify TI and its representatives against any damages arising out of the use of any TI components in safety-critical applications.

In some cases, TI components may be promoted specifically to facilitate safety-related applications. With such components, TI's goal is to help enable customers to design and create their own end-product solutions that meet applicable functional safety standards and requirements. Nonetheless, such components are subject to these terms.

No TI components are authorized for use in FDA Class III (or similar life-critical medical equipment) unless authorized officers of the parties have executed a special agreement specifically governing such use.

Only those TI components which TI has specifically designated as military grade or "enhanced plastic" are designed and intended for use in military/aerospace applications or environments. Buyer acknowledges and agrees that any military or aerospace use of TI components which have **not** been so designated is solely at the Buyer's risk, and that Buyer is solely responsible for compliance with all legal and regulatory requirements in connection with such use.

TI has specifically designated certain components as meeting ISO/TS16949 requirements, mainly for automotive use. In any case of use of non-designated products, TI will not be responsible for any failure to meet ISO/TS16949.

### Products

Audio	<a href="http://www.ti.com/audio">www.ti.com/audio</a>
Amplifiers	<a href="http://amplifier.ti.com">amplifier.ti.com</a>
Data Converters	<a href="http://dataconverter.ti.com">dataconverter.ti.com</a>
DLP® Products	<a href="http://www.dlp.com">www.dlp.com</a>
DSP	<a href="http://dsp.ti.com">dsp.ti.com</a>
Clocks and Timers	<a href="http://www.ti.com/clocks">www.ti.com/clocks</a>
Interface	<a href="http://interface.ti.com">interface.ti.com</a>
Logic	<a href="http://logic.ti.com">logic.ti.com</a>
Power Mgmt	<a href="http://power.ti.com">power.ti.com</a>
Microcontrollers	<a href="http://microcontroller.ti.com">microcontroller.ti.com</a>
RFID	<a href="http://www.ti-rfid.com">www.ti-rfid.com</a>
OMAP Applications Processors	<a href="http://www.ti.com/omap">www.ti.com/omap</a>
Wireless Connectivity	<a href="http://www.ti.com/wirelessconnectivity">www.ti.com/wirelessconnectivity</a>

### Applications

Automotive and Transportation	<a href="http://www.ti.com/automotive">www.ti.com/automotive</a>
Communications and Telecom	<a href="http://www.ti.com/communications">www.ti.com/communications</a>
Computers and Peripherals	<a href="http://www.ti.com/computers">www.ti.com/computers</a>
Consumer Electronics	<a href="http://www.ti.com/consumer-apps">www.ti.com/consumer-apps</a>
Energy and Lighting	<a href="http://www.ti.com/energy">www.ti.com/energy</a>
Industrial	<a href="http://www.ti.com/industrial">www.ti.com/industrial</a>
Medical	<a href="http://www.ti.com/medical">www.ti.com/medical</a>
Security	<a href="http://www.ti.com/security">www.ti.com/security</a>
Space, Avionics and Defense	<a href="http://www.ti.com/space-avionics-defense">www.ti.com/space-avionics-defense</a>
Video and Imaging	<a href="http://www.ti.com/video">www.ti.com/video</a>

### TI E2E Community

[e2e.ti.com](http://e2e.ti.com)