



深圳市首韩科技有限公司

SHENZHEN SHOUHAN TECHNOLOGY CO., LTD

Tel: 0755-27597601 Fax: 0755-27597491

承 认 书
SPECIFICATION FOR APPROVAL

客 户 Customer:

产品名称 Project:

轻触开关

规格型号 Part No:

TS5208A 160gf

贵公司承认印 Approval signatures

| 料 号/Part No. | 签 章/Signatures |
|--------------|----------------|
| | |

日期 Date:

| | | |
|-------------|-----|--|
| 拟制/Drawn | 李春风 |  |
| 审核/Check | 张栋 | |
| 批准/Approved | 罗孝金 | |



产 品 规 格 书

PRODUCT SPECIFICATION

| | | | |
|-------------------------------|------------------------------------|--|---|
| SIRLES | | 系列:FLIP SWITCHES(轻触开关) | |
| MODEL | | 型号: TS5208A 160gf | |
| 1.RATING | | 额定值:50mA 12V DC | |
| 2.CONSTRUTION DIMENSION 结构尺寸 | | Apply to the appended drawing:符合附加图纸 | |
| 3.APPEARANCE 外观 | | Have no remarkable damage,crack and rust etc:无明显损伤,裂纹,锈迹等. | |
| 4.CONTACTLOOP 接触回路 | | Monople loop:单通单极回路 | |
| ITEM 专案 | TEST CONDITION 测试条件 | SPECIFICATION 规格 | |
| 5.CAPABILITY OF ELECTRIC 电气性能 | | | |
| 5A | INSULATION RESISTANCE 绝缘电阻 | Measurements shall be made following Application of DC500V potential across terminals and across terminals and fuame for 1minute,在端子之间和端子与壳之间加 DC250V 条件下,持续 1 分钟测量. | 100M Ω min 100 M Ω 以上. |
| 5B | WITHSTAND VILTAGE 耐电压 | AC250V、50HZ、1 min (imin(interrupting current \leq 500uA). AC250V、50HZ、1 分钟(漏电流 500uA) | There shall be no briakdown 无击穿现象出现。 |
| 5C | CONTACT CIRCUIT 接触电路 | Addition 1.5-2 time force on the top of the keystrok and press the switch,DC50V100mA 在按键顶端上等于作用力 1.5-2 倍的力按动开关,DC50V,10Ma. | 50m Ω Max (50m Ω 以下). |
| 5D | SWITCH CONNECTION FLASH 开关接触点抖动 | Addition DC5V on the two side of switch,at a speed of 3-5time a sec.to press the switch.在开关的两端加 DC5V 的电压,以 3-5 次/秒的速度按动开关. | The flash time between open not more than 10ms. 开关在接通和断开时的接点抖动时间不大于 10 ms. |
| 6.MECHANICAL EFFICIENCY 机械性能 | | | |
| 6A | CONTACT STRENGTH 按键强度 | The contact shall be capable of a rorce of 5N for 5 seconds in any directions.沿开关动作方向可承受静能压力 5N, 保持 5 秒钟. | Switch electric andmechanical efficiency does not break 无损开关电气或者机械性能 |
| 6B | CONTACT JOURNEY | | 按键行程 0.15 \pm 0.05mm |
| 6C | DRIVE FORCE 驱动力 | Being measure at across spring piece and across keystoke forergometer. 用测力计在按键与弹片之间测量. | Contact switch'sd drive dirive fouce was160 \pm 30gf. 按键的开关驱动力为 160 \pm 30gf |

| | | | |
|---|---|---|--|
| 6D | CONNECTION STRENGTH 接线端强度 | A force of 1N being applying in any directions of the switch connection partt..在接线端的作用方向施加 1N 的力. | Switch mechanical efficiency does not break.无损开关机械性能. |
| 6E | MECHANICAL LIFE 机械寿命 | Operatin at a rate of 30-50 cycles a minute. 以 30-50 次/分的驱动速度操作. | Life:100000cycles 寿命:100000次 |
| 7.ENVIRONME NT---RESISTANT EFFICIENCY 耐环境性能 | | | |
| 7A | CHANGE OF TEMPERATURE 温度变化 | The first temperature shall be 70 °C ,3h and changed to-25°C, 0.5h, 5cycles of above test. 先 70°C, 3h, 然后-25°C, 0.5h, 如此重复 5 次. | 1. The appearance should not break.外观应无损伤. 2. Contact resistance $\leq 100 M \Omega$ 接触电阻 $\leq 100M\Omega$ |
| 7B | HUMIDITY RESISTANT 耐湿热 | 40 \pm 2°C in temperature and 90-95%RH, Ruring thetest time without load; After testing the temperature should be 24h. 经 40 \pm 2°C, 相对湿度 90-95%, 试验期间, 开关不动作, 不带电负荷, 试验后恢复到常温 24h. | 3. Insulation resistance $\geq 100 M \Omega$. 绝缘电阻 $\geq 100 M \Omega$ |
| 8.IOINTING EFFICIENCY 焊接性能 | | | |
| 8A | SOLDERABILITY 可焊性 | Temperature260 \pm 5 °C ;Duration;3 \pm 0.5S:温度在 260 \pm 5°C, 持续 3 \pm 0.5S. | Solderability part should above 90% 可焊部分被焊料覆盖面应在 90% 以上. |
| 8B | SOLDER—RESISTANT 耐焊剂性 | Warm-up temperature:100°C,40S, 焊锡温度 260 \pm 5 °C, 浸焊时间 5 \pm 0.5S. | Froth height of assist solder should under board and switch electric and mechanical efficien- cy does not break.助焊剂发泡不应超过印制板,无损伤开关电气或机械动作性能. |
| 8C | JOINTING—RESISTANT 耐焊接热 | Jointing temperature: 260 \pm 5 °C ,Duration of immersion: 5 \pm 1S. 焊锡温度 260 \pm 5°C, 浸焊时间 5 \pm 1S | efficiency does not break 无损伤开关电气或机械动作性能. |
| 8D | NORMAL JOLNTING TIMES 正常焊接次数 | | ≤ 2 times 小于 2 次 |
| 9.NOTES | | | |
| 9A | The whole boxes of switch should keep in the temperature -30--80 °C and less than 80%RH withort acidic,alkalescence,caustic gas in the environment of the storage. 整箱包装的开关,应在温度为-30--80°C,相对湿度不大于 80%,周围的空气中没有酸性、碱性或其他腐蚀性气体的库房内保管。 | | |
| 9B | Operating Temperature Range:-20 to 70°C 操作温度的范围: -25 to 70°C | | |
| 9C | Switch should install in a correct method. 开关应按正确的安装方法进行正确安装使用。 | | |

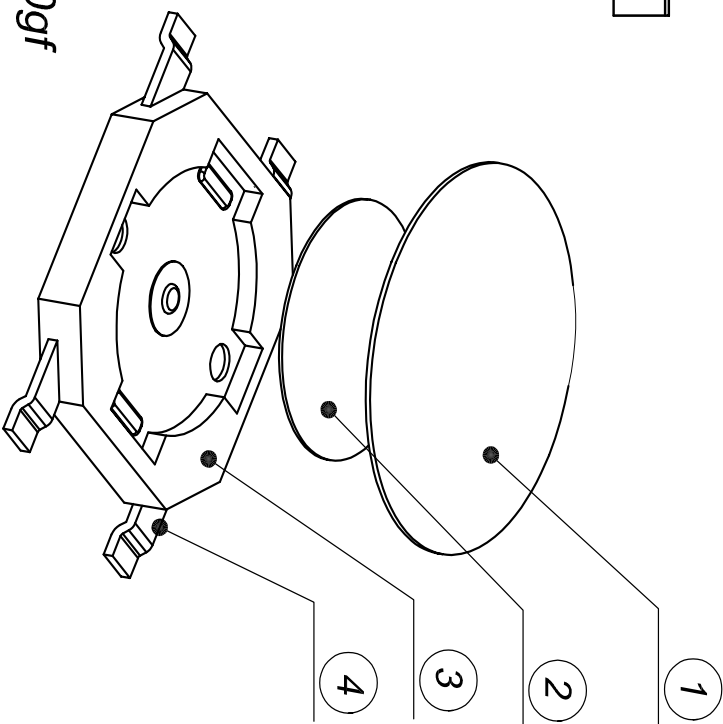
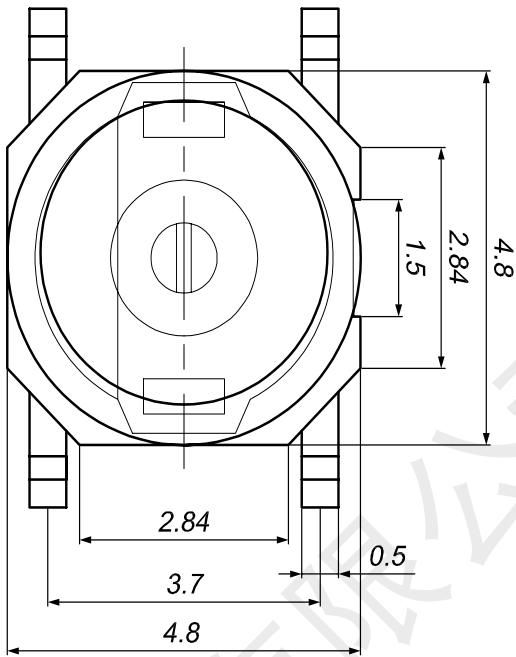

1. Rating: DC12V 50mA.
2. Travel: 0.15±0.05mm.
3. Operating Force: 160±30gf
4. Contact Resistance: 50mΩMax.
5. Life: 100,000 Cycles Min.

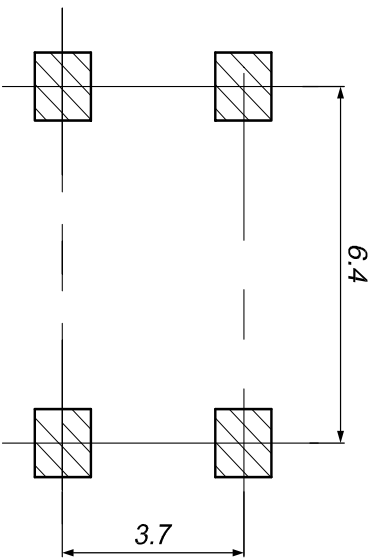

电路简图
SCHEMATIC

印制线路板
Recommended P.C.B layout

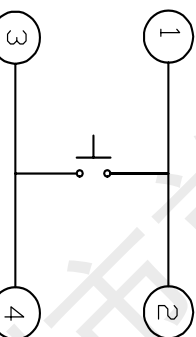

| 序号 NO. | 名称 DESCRIPTION | 材料 MATERIAL | 颜色 COLOR | 备注 REMARK |
|-----------|-------------------|----------------|-------------|--------------|
| 4 | 嵌件 | 磷铜 | — | 镀银 |
| 3 | 底座 | PA46 | — | — |
| 2 | 簧片 | 不锈钢 | — | 材料进口 |
| 1 | 防水层 | 防水胶片 | — | — |

首韩
SHOHAN
深圳市首韩科技有限公司

CUSTOMER 名称
COPY TITLE: 轻触开关

TYPE NO. TSS5208A 160gf

MATERIAL ARAM3.608.014.AZ

DRAWING NO. 8SCALE UNIT mm A4

| | | | | | | | | | | | | |
|------------------------|-----|----------|-------------|--------------|----|---|-----------------|----------|-----|----------------|-------------------|--------|
| 工程变更通知单 EN(OCN) NO. | REV | DATE | DESCRIPTION | 变更 CHANGE | 承認 | GENERAL TOLERANCE UNLESS OTHERWISE NOTED | DESIGN CHECK | 設計 校閱 | 李春风 | 材料 MATERIAL | 圖號 DRAWING NO. | 8SCALE |
| | PA | 06/03/28 | NEW | | | | CHECK | 審定 | 张栋 | | | |
| | | | | | | | APPRO. | 承認 | 罗孝金 | | | |