



**Series 804 Push-Pull High-Speed Mighty Mouse**  
**Rear and Front Mount Jam-Nut PCB or Solder Cup Receptacle**  
**804-030 and 804-031 Ordering Information**



Series 804  
High-Speed

**Rear panel jam nut 804-030/031 - shell style 07**

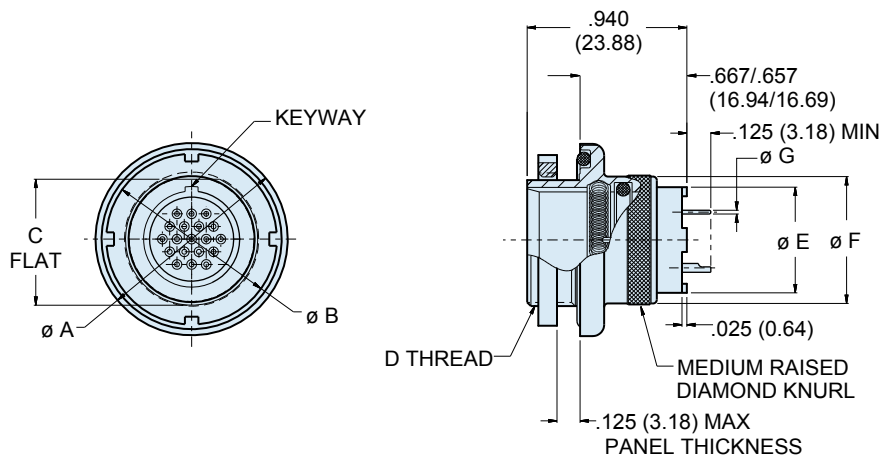

Shell Size	M Flat		Ø N	
	In.	mm.	In.	mm.
6	.479 .475	12.17 12.07	.510	12.95
7	.606 .602	15.39 15.29	.635	16.13
9	.667 .663	16.94 16.84	.698	17.73
10	.734 .729	18.64 18.52	.760	19.30

Dimensions												
Shell Size	Ø A		Ø B		C Flat		D Threads	Ø E		Ø F		Ø F Tail Dia.
	In.	mm.	In.	mm.	In.	mm.		In.	mm.	In.	mm.	
6	.730	18.54	.625	15.87	.467	14.40	.5000-32 UN-2A	.330	8.38	.483	12.27	.018/.022 (.46/.56)
7	.910	23.11	.750	19.05	.594	15.09	.6250-28 UN-2A	.432	10.97	.570	14.48	
9	1.000	25.40	.812	20.62	.655	16.64	.6875-28 UN-2A	.551	14.00	.685	17.40	
10	1.085	27.48	.875	22.22	.721	18.31	.7500-28 UN-2A	.620	15.75	.725	18.42	

Receptacle Key Positions		
Position	A°	B°
A	150°	210°
B	75°	210°
C	95°	230°
D	140°	275°
E	75°	275°
F	95°	210°

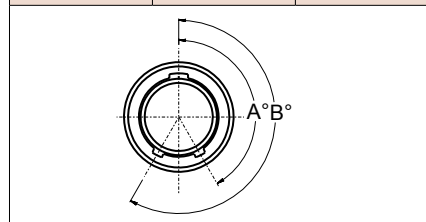

**Front panel jam nut 804-030/031 - shell style 00**

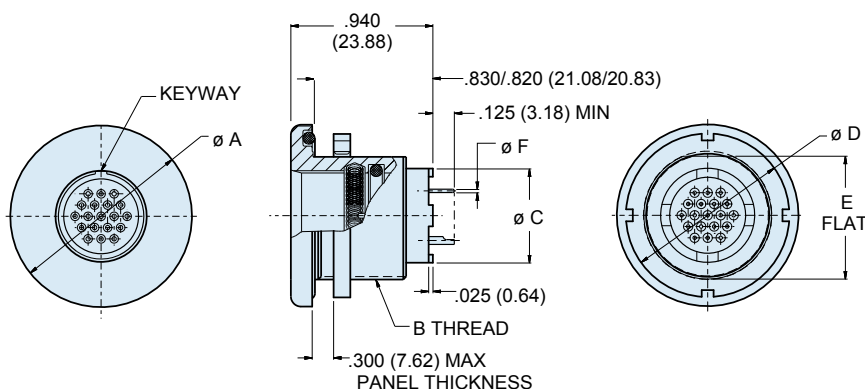

Dimensions										
Shell Size	Ø A		B Threads	Ø C		Ø D		E Flat		Ø F Tail Dia.
	In.	mm.		In.	mm.	In.	mm.	In.	mm.	
6	.885	22.48	.5625-28 UN-2A	.330	8.38	.688	17.47	.530	13.46	.018/.022 (.46/.56)
7	.995	25.27	.6875-28 UN-2A	.432	10.97	.812	20.62	.663	16.84	
9	1.075	27.31	.7500-28 UN-2A	.551	14.00	.875	22.22	.720	18.29	
10	1.140	28.95	.8125-28 UN-2A	.620	15.75	.938	23.82	.788	20.02	

Front Mount Jam Nut Panel Cutout				
Shell Size	P Flat		Ø R	
	In.	mm.	In.	mm.
6	.542 .538	13.77 13.67	.575	14.61
7	.676 .671	17.17 17.04	.698	17.73
9	.732 .728	18.59 18.49	.760	19.30
10	.801 .796	20.35 20.22	.822	20.88

Dimensions in Inches (millimeters) are subject to change without notice.