

Technical data

Losses (dielectric)		< 0,25 W/kvar
Dielectric dissipation factortan δ_0		$2 \cdot 10^{-4}$
Overvoltage		$U_N + 10\%$ (up to 8 hours daily) $U_N + 15\%$ (up to 30 hours daily) $U_N + 20\%$ (up to 5 minutes) $U_N + 30\%$ (up to 1 minute)
Overcurrent		$1,3 \cdot I_N$ $1,5 \cdot I_N$ with 10 % overvoltage, 15 % over-capacitance and harmonics included
Inrush current		up to 300 times rated current
Ambient temperature category		-25/D
Lower category temperature	Θ_{\min}	- 25 °C
Upper category temperature	Θ_{\max}	+ 55 °C
Average rel. humidity		≤ 75 %
Storage temperature limit	Θ_{stg}	- 55/+ 70 °C
Load duration (service life)	$t_{LD(\text{co})}$	100 000 operating hours
Degree of protection		IP 20, indoor mounting (optionally with capacitor cover for IP 55)
Test data:		
AC test voltage		
between terminals	U_{TT}	$2,15 \cdot U_N$, 50 Hz, 10 s
between terminals and case	U_{TC}	$U_N \leq 660 \text{ V}$: 3000 Vac, 50 Hz, 10 s $U_N > 660 \text{ V}$: 6000 Vac, 50 Hz, 10 s
Dissipation factor (50 Hz)	tan δ	≤ $10 \cdot 10^{-4}$

B 25 667

Power Factor Correction and Filtering

Available ratings

3-phase capacitors

U_N (V)	AC	230	400	415	440	480	525	690
Output (kvar, 50 Hz)								
2,5								
5,0								
6,3								
7,5								
8,3								
10,0								
10,4								
11,2								
12,5								
14,2								
15,0								
16,7								
18,8								
20,8								
25,0								

1-phase capacitors

2,5								
3,3								
5,0								
5,2								
6,3								
6,5								
7,5								
8,3								
10,0								
10,4								
12,5								
15,0								

 Data book range

Characteristics and ordering codes for three-phase capacitors

50 Hz		60 Hz		$C_N^{1)}$	Dimensions	Appr.	Type	Ordering	Pg.	
Q_N	I_N	Q_N	I_N	μF	$d \times h$	weight	MKK-	code ²⁾		
kvar	A	kvar	A		mm	kg		B25667-		
$U_N = 230 \text{ Vac (phase/phase)}$										
2,5	6,3	3,0	7,5	3×50	121×164	1,2	230-D-02,5-01	-A2157-A375	320	
5,0	12,6	6,3	15,7	3×104	121×164	1,3	230-D-05-01	-A2317-A375		
7,5	18,8	9,0	22,6	3×150	121×164	1,3	230-D-07,5-01	-A2457-A375		
10,4	26,1	12,5	31,4	3×209	121×164	1,5	230-D-10-01	-A2627-A375		
12,5	31,4	—	—	3×250	121×200	1,7	230-D-12,5-01	-A2757-A375		
$U_N = 400 \text{ Vac (phase/phase)}$										
5,0	7,2	6,0	8,7	3×33	121×164	1,2	400-D-05-01	-A3996-A375	322	
6,3	9,0	7,5	10,8	3×42	121×164	1,2	400-D-06,3-01	-A3127-A375		
7,5	10,8	9,0	13,0	3×50	121×164	1,2	400-D-07,5-01	-A3147-A375		
8,3	12,0	10,0	14,5	3×55	121×164	1,3	400-D-08,33-01	-A3167-A375		
10,4	15,0	12,0	18,0	3×69	121×164	1,3	400-D-10-01	-A3207-A375		
12,5	18,0	15,0	21,7	3×83	121×164	1,3	400-D-12,5-01	-A3247-A375		
15,0	21,7	18,0	26,0	3×100	121×164	1,5	400-D-15-01	-A3297-A375		
16,7	24,0	20,0	29,0	3×111	121×200	1,6	400-D-16,7-01	-A3337-A375		
20,8	30,0	25,0	36,0	3×138	142×200	2,0	400-D-20-01	-A3417-A375		
25,0	36,0	—	—	3×166	142×200	2,2	400-D-25-01	-A3497-A375		
$U_N = 415 \text{ Vac (phase/phase)}$										
5,0	7,0	6,0	8,4	3×31	121×164	1,2	415-D-05-01	-A4926-A375	326	
6,3	8,7	7,5	10,5	3×39	121×164	1,2	415-D-06,3-01	-A4117-A375		
10,4	14,5	12,5	17,4	3×64	121×164	1,2	415-D-10-01	-A4197-A375		
12,5	17,4	15,0	20,9	3×77	121×164	1,3	415-D-12,5-01	-A4237-A375		
15,0	20,9	18,0	25,0	3×93	121×164	1,4	415-D-15-01	-A4277-A375		
16,7	23,3	20,0	27,9	3×103	121×164	1,5	415-D-16,7-01	-A4307-A375		
20,8	29,0	—	—	3×128	121×200	1,7	415-D-20-01	-A4387-A375		
25,0	34,8	—	—	3×154	142×200	2,1	415-D-25-01	-A4467-A375		
$U_N = 440 \text{ Vac (phase/phase)}$										
5,0	6,6	6,0	7,9	3×27	121×164	1,2	440-D-05-01	-A4826-A375		326
7,5	9,9	9,0	11,8	3×41	121×164	1,2	440-D-07,5-01	-A4127-A375		
10,4	13,7	12,5	16,4	3×57	121×164	1,3	440-D-10-01	-A4177-A375		
11,2	14,7	13,5	17,7	3×61	121×164	1,4	440-D-11,2-01	-A4187-A375		
12,5	16,4	15,0	19,7	3×69	121×164	1,4	440-D-12,5-01	-A4207-A375		
14,2	18,7	17,0	22,4	3×78	121×164	1,5	440-D-14,2-01	-A4237-A365		

More values for $U_N = 440 \text{ V}$, cont'd on next page

1) Capacitance tolerance – 5/+ 10 %
2) Example: B25667-A2157-A375

B 25 667 Power Factor Correction and Filtering

Characteristics and ordering codes for three-phase capacitors

50 Hz		60 Hz		C_N ¹⁾	Dimensions	Appr.	Type	Ordering	Pg.	
Q_N kvar	I_N A	Q_N kvar	I_N A	μF	$d \times h$ mm	weight kg	MKK-	code ²⁾ B25667-		
$U_N = 440 \text{ Vac (phase/phase)}$										
15,0	19,7	18,0	23,7	3×82	121×164	1,6	440-D-15-01	-A4247-A375	328	
16,7	21,9	20,0	26,3	3×92	121×200	1,7	440-D-16,7-01	-A4277-A365		
18,8	24,7	22,5	29,6	3×103	142×200	2,0	440-D-18,8-01	-A4307-A365		
20,8	27,3	25,0	32,8	3×114	142×200	2,1	440-D-20-01	-A4347-A375		
25,0	32,8	—	—	3×137	142×200	2,3	440-D-25-01	-A4417-A375		
$U_N = 480 \text{ Vac (phase/phase)}$										
5,0	6,0	6,0	7,2	3×23	121×164	1,1	480-D-05-01	-A4696-A375	330	
6,3	7,5	7,5	9,0	3×29	121×164	1,2	480-D-06,3-01	-A4866-A375		
7,5	9,0	9,0	10,8	3×35	121×164	1,2	480-D-07,5-01	-A4107-A375		
8,3	10,0	10,0	12,0	3×38	121×164	1,2	480-D-08,3-01	-A4117-A365		
10,4	12,5	12,5	15,0	3×48	121×164	1,3	480-D-10-01	-A4147-A375		
12,5	15,0	15,0	18,0	3×58	121×164	1,5	480-D-12,5-01	-A4177-A365		
15,0	18,0	18,0	21,7	3×69	121×200	1,7	480-D-15-01	-A4207-A365		
16,7	20,0	20,0	24,0	3×77	121×200	1,8	480-D-16,7-01	-A4237-A355		
20,8	25,0	25,0	30,0	3×96	142×200	2,2	480-D-20-01	-A4287-A375		
25,0	30,0	—	—	3×115	142×200	2,4	480-D-25-01	-A4347-A365		
$U_N = 525 \text{ Vac (phase/phase)}$										
6,3	6,9	7,5	8,3	3×24	121×164	1,1	525-D-06,25-01	-A5726-A375		332
8,3	9,2	10,0	11,0	3×32	121×164	1,2	525-D-08,3-01	-A5966-A375		
10,4	11,5	12,5	13,7	3×40	121×164	1,4	525-D-10-01	-A5127-A375		
12,5	13,8	15,0	16,5	3×48	121×164	1,5	525-D-12,5-01	-A5147-A375		
15,0	16,5	18,0	19,8	3×58	121×200	1,7	525-D-15-01	-A5177-A375		
16,7	18,4	20,0	22,0	3×64	121×200	1,8	525-D-16,7-01	-A5197-A375		
20,8	22,9	25,0	27,5	3×80	142×200	2,2	525-D-20-01	-A5247-A375		
25,0	27,5	—	—	3×96	142×200	2,5	525-D-25-01	-A5287-A375		
$U_N = 690 \text{ Vac (phase/phase)}^3)$										
5,0	4,2	6,0	5,0	3×33	121×164	1,2	690-Y-05-01	-A6996-A375	334	
10,0	8,4	12,5	10,5	3×70	121×164	1,3	690-Y-10-01	-A6207-A375		
12,5	10,5	15,0	12,5	3×84	121×164	1,4	690-Y-12,5-01	-A6257-A375		
15,0	12,6	18,0	15,0	3×100	121×164	1,5	690-Y-15-01	-A6307-A375		
20,8	17,4	—	—	3×139	142×200	2,0	690-Y-20-01	-A6417-A375		
25,0	21,0	—	—	3×167	142×200	2,2	690-Y-25-01	-A6507-A375		

1) Capacitance tolerance – 5/+ 10 %

2) Example: B25667-A4247-A375

3) Star connection: the triple capacitance of a delta connection is stated (refer also to section 3.4.2).

Characteristics and ordering codes for single-phase capacitors

50 Hz		60 Hz		$C_N^{1)}$	Dimensions	Appr.	Type	Ordering	Pg.
Q_N	I_N	Q_N	I_N	μF	$d \times h$	weight	MKK-	code ²⁾	
kvar	A	kvar	A		mm	kg		B25667-	
$U_N = 230 \text{ Vac (phase/neutral)}$									
2,5	10,9	3,0	13,0	150	121 × 164	1,1	230-I-02,5-01	-A2157-A175	336
3,3	14,5	4,0	17,4	200	121 × 164	1,1	230-I-03,3-01	-A2207-A175	
5,2	22,6	6,2	27,0	313	121 × 164	1,1	230-I-05-01	-A2317-A175	
8,3	36,2	—	—	502	121 × 164	1,3	230-I-08,3-01	-A2507-A175	
$U_N = 400 \text{ Vac (phase/neutral)}$									
5,0	12,5	6,0	15,0	100	121 × 164	1,1	400-I-05-01	-A3107-A175	338
6,3	15,6	7,5	18,8	124	121 × 164	1,1	400-I-06,3-01	-A3127-A175	
7,5	18,8	9,0	22,5	149	121 × 164	1,1	400-I-07,5-01	-A3147-A175	
8,3	20,8	10,0	25,0	166	121 × 164	1,1	400-I-08,3-01	-A3167-A175	
10,4	26,0	12,5	31,2	207	121 × 164	1,2	400-I-10,4-01	-A3207-A175	
12,5	31,3	15,0	37,5	249	121 × 164	1,3	400-I-12,5-01	-A3247-A175	
$U_N = 525 \text{ Vac (phase/neutral)}$									
6,5	12,4	7,8	14,9	75	121 × 164	1,1	525-I-06,5-01	-A5756-A175	340
8,3	15,9	10,0	19,0	96	121 × 164	1,2	525-I-08,3-01	-A5966-A175	
10,0	19,0	12,0	22,9	116	121 × 164	1,3	525-I-10-01	-A5117-A175	
12,5	23,8	15,0	28,6	144	121 × 164	1,5	525-I-12,5-01	-A5147-A175	
15,0	28,5	18,0	34,3	173	121 × 200	1,7	525-I-15-01	-A5177-A175	

1) Capacitance tolerance – 5/+ 10 %

2) Example: B25667-A2157-A175

B 25 667

Power Factor Correction and Filtering

Dimensional drawing

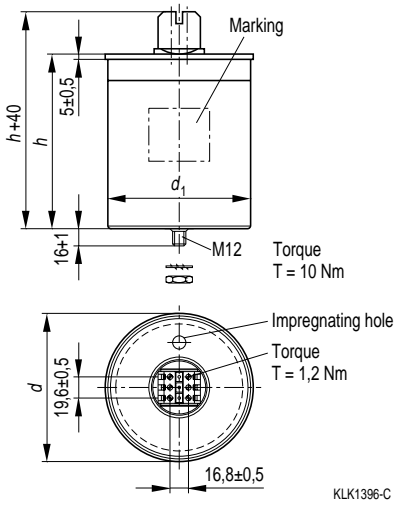

Dimensions in mm

$\varnothing d -1,5$	$h \pm 2,0$	$\varnothing d_1 -0,6$	Creepage distance min.	Clearance min.
121,6	164	116,2	12,7	9,6
121,6	200	116,2	12,7	9,6
142	200	136,6	12,7	9,6

Mounting parts

Toothed washer J12,5 DIN 6797

Hex nut M12 ISO 4035

or

nut C61010-A415-C15

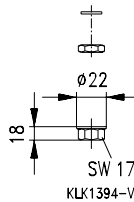

Included in delivery:

Discharge resistors

Hex nut

Toothed washer

Protection covers

Molded plastic capacitor cover

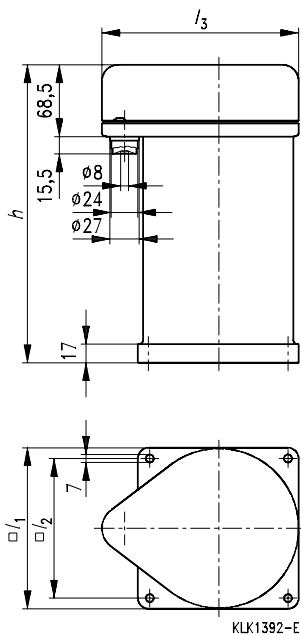

Molded plastic terminal cover

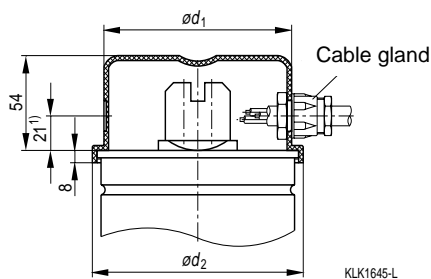

Capacitor cover

Capacitor diameter	Degree of protection	Ordering code	Dimensions (mm)				Weight g
			l_1	l_2	l_3	h	
121,6 mm	IP55	B44066-X9122	134	110	177	243	300
142,0 mm	IP55	B44066-X9142	154,5	130,5	186	280	600

Terminal cover

Capacitor diameter	For cable gland	For cable diameter	Ordering code	Dimensions (mm)	
				$\varnothing d_1$	$\varnothing d_2$
121,6 mm	PG 13,5	9 ... 13 mm	B44066-K1211	116	125
121,6 mm	PG 16	10 ... 14 mm	B44066-K1212	116	125
142,0 mm	PG 21	14 ... 18 mm	B44066-K1421	137	145

1) Perforation for second cable gland

B 25 667

Power Factor Correction and Filtering

230 Vac / 3 ph / 12,5 kvar
MKK-230-D-12,5-01

Ordering code: B25667-A2757-A375

Characteristics

C_N , tol.	$3 \times 250,8 \mu\text{F} +10/-5 \%$
Q_N	12,5 kvar
U_N	AC 230 V
f_N	50 Hz
I_N	$3 \times 31,4 \text{ A}$
$\tan \delta_0$	$2 \cdot 10^{-4}$

Maximum ratings

U_{max}	$1,1 \cdot U_N$, 8 h daily
I_{max}	$1,3 \cdot I_N$
I_s	$200 \cdot I_N$
$(du/dt)_{\text{max}}$	8 V/ μs
$(du/dt)_s$	20 V/ μs

Test data

U_{TT}	AC 500 V, 10 s
U_{TC}	AC 3000 V, 50 Hz, 10 s
$\tan \delta$ (50 Hz)	$\leq 9 \cdot 10^{-4}$

Climatic category – 25/D

Θ_{min}	- 25 °C
Θ_{max}	+ 55 °C
Humidity	Average relative humidity $\leq 75 \%$
$t_{LD(\text{co})}$	100000 h
Θ_{stg}	- 55 to + 70 °C

Remarks

Natural cooling
Delta connection
IEC 831-1/2, EN 60831-1/2, VDE 560-46/47

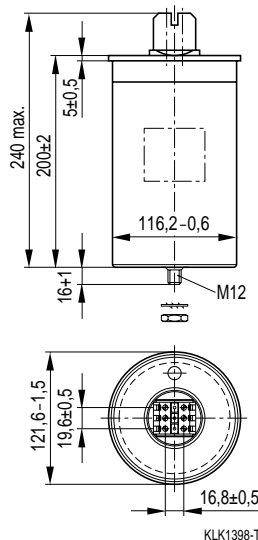

Design data

Dimensions $\varnothing \times l$	121,6 mm \times 200 mm
Approx. weight	1700 g
Impregnation	Gas
Fixing	Threaded bolt M12
Mounting hole	14 mm
Max. torque	10 Nm
Terminals	Safe-to-touch terminals
Max. torque	1,2 Nm
Terminal cross section	16 mm ²
Creepage distance	12,7 mm
Clearance	9,6 mm
Overpressure disconnecter	
Any mounting position	
Black painted case	

Thermal data

B25667-A2757-A375

Dielectric power dissipation P_D
versus repetition frequency f_0

$U_N = AC\ 230\ V$ —————
 $0,9 \cdot U_N = AC\ 207\ V$ - - - - -

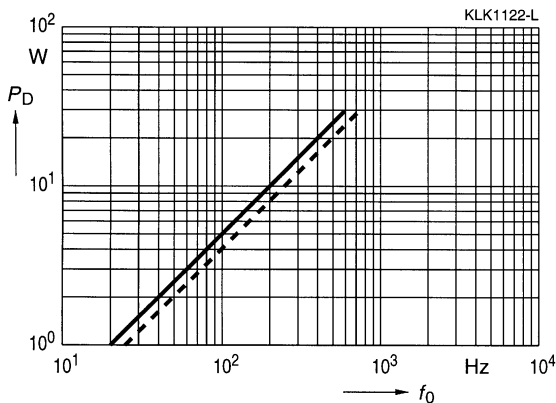

Ohmic power dissipation P_R
versus rms current value I

$R_S (70\ ^\circ C) = 9,5\ m\Omega$

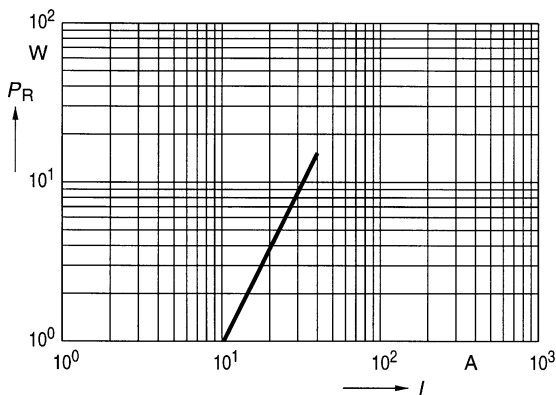

Permissible ambient temperature Θ_A
versus total power dissipation P

Natural cooling —————
Forced cooling 2 m/s - - - - -
Permissible capacitor
temperature - · - · - · -

black painted

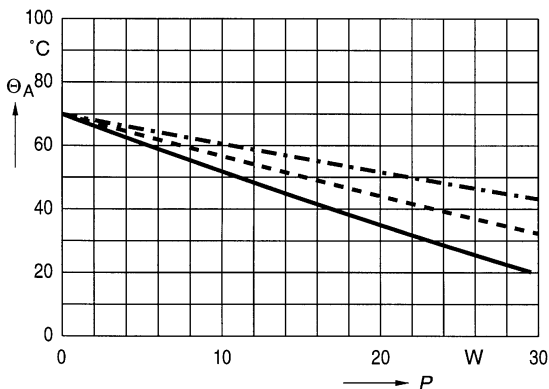

B 25 667

Power Factor Correction and Filtering

400 Vac / 3 ph / 12,5 kvar
MKK-400-D-12,5-01

Ordering code: B25667-A3247-A375

Characteristics

C_N , tol.	$3 \times 82,9 \mu\text{F} +10/-5 \%$
Q_N	12,5 kvar
U_N	AC 400 V
f_N	50 Hz
I_N	$3 \times 18 \text{ A}$
$\tan \delta_0$	$2 \cdot 10^{-4}$

Maximum ratings

U_{max}	$1,1 \cdot U_N$, 8 h daily
I_{max}	$1,3 \cdot I_N$
I_s	$200 \cdot I_N$
$(du/dt)_{\text{max}}$	14 V/ μs
$(du/dt)_s$	35 V/ μs

Test data

U_{TT}	AC 860 V, 10 s
U_{TC}	AC 3000 V, 50 Hz, 10 s
$\tan \delta$ (50 Hz)	$\leq 6 \cdot 10^{-4}$

Climatic category – 25/D

Θ_{min}	- 25 °C
Θ_{max}	+ 55 °C
Humidity	Average relative humidity $\leq 75 \%$
$t_{LD(\text{co})}$	100000 h
Θ_{stg}	- 55 to + 70 °C

Remarks

Natural cooling
Delta connection
IEC 831-1/2, EN 60831-1/2, VDE 560-46/47

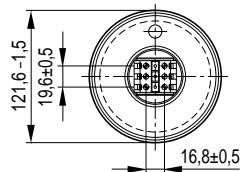
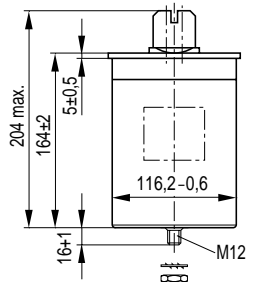

Design data

Dimensions $\varnothing \times l$	121,6 mm \times 164 mm
Approx. weight	1300 g
Impregnation	Gas
Fixing	Threaded bolt M12
Mounting hole	14 mm
Max. torque	10 Nm
Terminals	Safe-to-touch terminals
Max. torque	1,2 Nm
Terminal cross section	16 mm ²
Creepage distance	12,7 mm
Clearance	9,6 mm
Overpressure disconnecter	
Any mounting position	
Black painted case	

Thermal data

B25667-A3247-A375

Dielectric power dissipation P_D
versus repetition frequency f_0

$U_N = AC\ 400\ V$ —————
 $0,9 \cdot U_N = AC\ 360\ V$ - - - - -

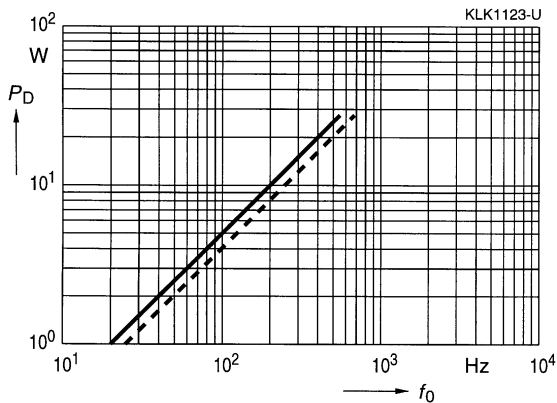

Ohmic power dissipation P_R
versus rms current value I

$R_S (70\ ^\circ C) = 12\ m\Omega$

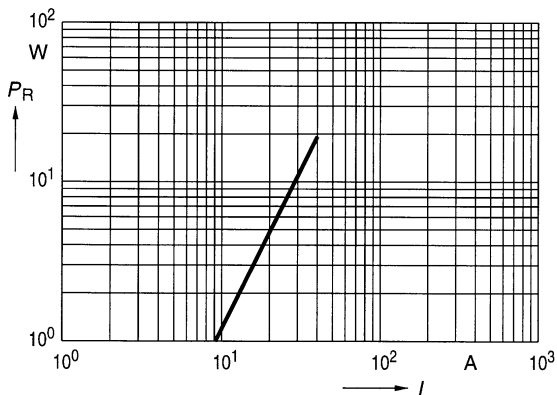

Permissible ambient temperature Θ_A
versus total power dissipation P

Natural cooling —————
Forced cooling 2 m/s - - - - -
Permissible capacitor
temperature - · - · - ·

black painted

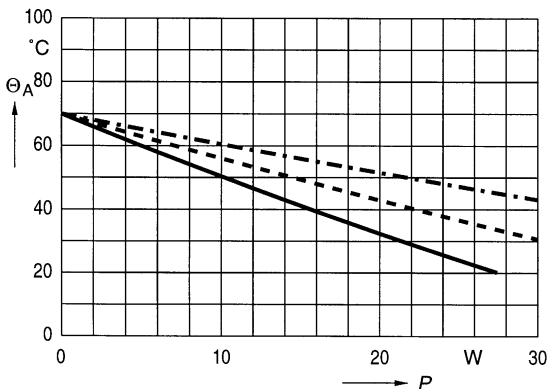

B 25 667

Power Factor Correction and Filtering

400 Vac / 3 ph / 25 kvar
MKK-400-D-25-01

Ordering code: B25667-A3497-A375

Characteristics

C_N , tol.	$3 \times 165,9 \mu\text{F} +10/-5 \%$
Q_N	25 kvar
U_N	AC 400 V
f_N	50 Hz
I_N	$3 \times 36,1 \text{ A}$
$\tan \delta_0$	$2 \cdot 10^{-4}$

Maximum ratings

U_{max}	$1,1 \cdot U_N$, 8 h daily
I_{max}	$1,3 \cdot I_N$
I_s	$200 \cdot I_N$
$(du/dt)_{\text{max}}$	10 V/ μs
$(du/dt)_s$	25 V/ μs

Test data

U_{TT}	AC 860 V, 10 s
U_{TC}	AC 3000 V, 50 Hz, 10 s
$\tan \delta$ (50 Hz)	$\leq 7 \cdot 10^{-4}$

Climatic category – 25/D

Θ_{min}	- 25 °C
Θ_{max}	+ 55 °C
Humidity	Average relative humidity $\leq 75 \%$
$t_{LD(\text{co})}$	100000 h
Θ_{stg}	- 55 to + 70 °C

Remarks

Natural cooling
Delta connection
IEC 831-1/2, EN 60831-1/2, VDE 560-46/47

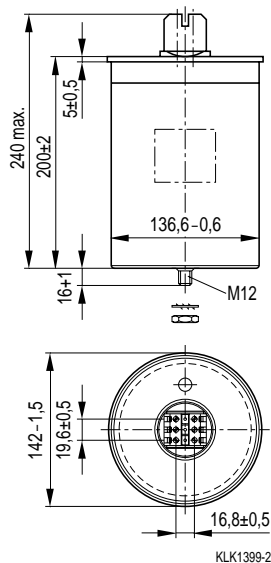

Design data

Dimensions $\varnothing \times l$	142 mm \times 200 mm
Approx. weight	2200 g
Impregnation	Gas
Fixing	Threaded bolt M12
Mounting hole	14 mm
Max. torque	10 Nm
Terminals	Safe-to-touch terminals
Max. torque	1,2 Nm
Terminal cross section	16 mm ²
Creepage distance	12,7 mm
Clearance	9,6 mm
Overpressure disconnecter	
Any mounting position	
Black painted case	

Thermal data

B25667-A3497-A375

Dielectric power dissipation P_D
versus repetition frequency f_0

$U_N = AC\ 400\ V$ —————
 $0,9 \cdot U_N = AC\ 360\ V$ - - - - -

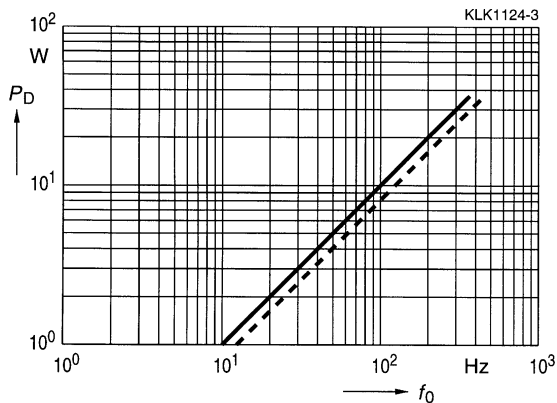

Ohmic power dissipation P_R
versus rms current value I

$R_S (70\ ^\circ C) = 9,8\ m\Omega$

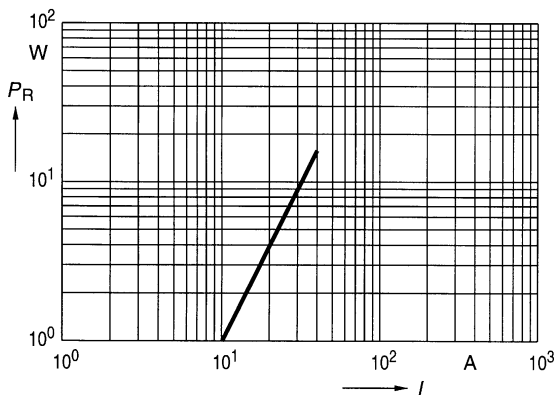

Permissible ambient temperature Θ_A
versus total power dissipation P

Natural cooling —————
Forced cooling 2 m/s - - - - -
Permissible capacitor
temperature - · - · - · -

black painted

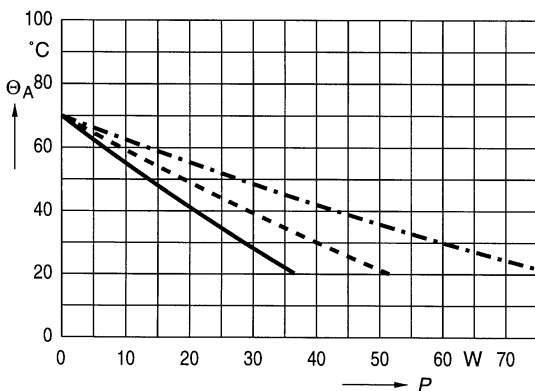

B 25 667

Power Factor Correction and Filtering

415 Vac / 3 ph / 25 kvar
MKK-415-D-25-01

Ordering code: B25667-A4467-A375

Characteristics

C_N , tol.	$3 \times 154,1 \mu\text{F} +10/-5 \%$
Q_N	25 kvar
U_N	AC 415 V
f_N	50 Hz
I_N	$3 \times 34,8 \text{ A}$
$\tan \delta_0$	$2 \cdot 10^{-4}$

Maximum ratings

U_{max}	$1,1 \cdot U_N$, 8 h daily
I_{max}	$1,3 \cdot I_N$
I_s	$200 \cdot I_N$
$(du/dt)_{\text{max}}$	10 V/ μs
$(du/dt)_s$	25 V/ μs

Test data

U_{TT}	AC 900 V, 10 s
U_{TC}	AC 3000 V, 50 Hz, 10 s
$\tan \delta$ (50 Hz)	$\leq 7 \cdot 10^{-4}$

Climatic category – 25/D

Θ_{min}	- 25 °C
Θ_{max}	+ 55 °C
Humidity	Average relative humidity $\leq 75 \%$
$t_{\text{LD(co)}}$	100000 h
Θ_{stg}	- 55 to + 70 °C

Remarks

Natural cooling
Delta connection
IEC 831-1/2, EN 60831-1/2, VDE 560-46/47

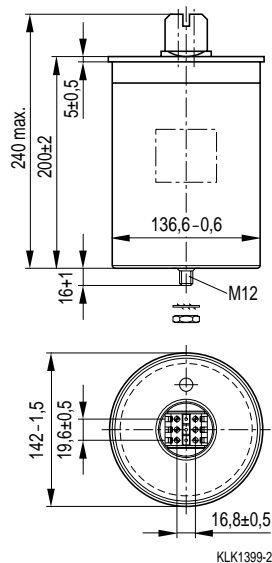

Design data

Dimensions $\varnothing \times l$	142 mm \times 200 mm
Approx. weight	2100 g
Impregnation	Gas
Fixing	Threaded bolt M12
Mounting hole	14 mm
Max. torque	10 Nm
Terminals	Safe-to-touch terminals
Max. torque	1,2 Nm
Terminal cross section	16 mm ²
Creepage distance	12,7 mm
Clearance	9,6 mm
Overpressure disconnecter	
Any mounting position	
Black painted case	

Thermal data

B25667-A4467-A375

Dielectric power dissipation P_D
versus repetition frequency f_0

$U_N = AC\ 415\ V$ —————
 $0,9 \cdot U_N = AC\ 374\ V$ - - - - -

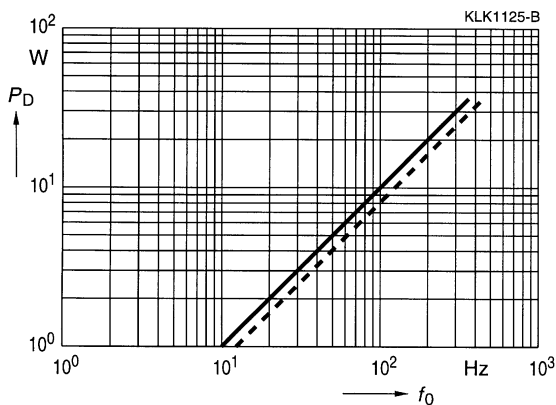

Ohmic power dissipation P_R
versus rms current value I

$R_S (70\ ^\circ C) = 11\ m\Omega$

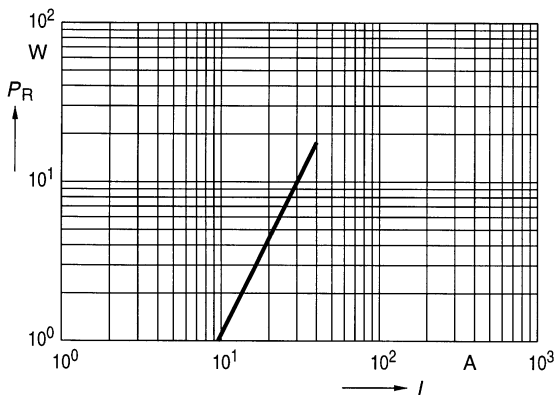

Permissible ambient temperature Θ_A
versus total power dissipation P

Natural cooling —————
Forced cooling 2 m/s - - - - -
Permissible capacitor
temperature - · - · - · -

black painted

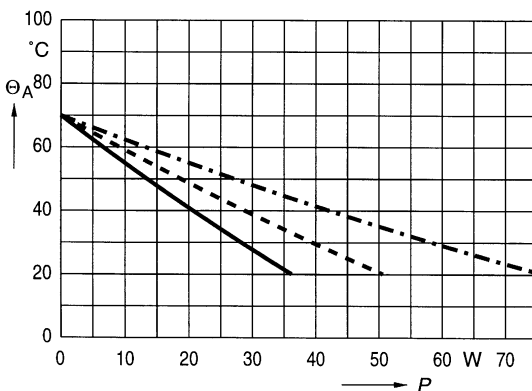

B 25 667

Power Factor Correction and Filtering

440 Vac / 3 ph / 18,8 kvar
MKK-440-D-18,8-01

Ordering code: B25667-A4307-A365

Characteristics

C_N , tol.	$3 \times 103,1 \mu\text{F} +10/-5 \%$
Q_N	18,8 kvar
U_N	AC 440 V
f_N	50 Hz
I_N	$3 \times 24,7 \text{ A}$
$\tan \delta_0$	$2 \cdot 10^{-4}$

Maximum ratings

U_{max}	$1,1 \cdot U_N$, 8 h daily
I_{max}	$1,3 \cdot I_N$
I_s	$200 \cdot I_N$
$(du/dt)_{\text{max}}$	12 V/ μs
$(du/dt)_s$	30 V/ μs

Test data

U_{TT}	AC 950 V, 10 s
U_{TC}	AC 3000 V, 50 Hz, 10 s
$\tan \delta$ (50 Hz)	$\leq 6 \cdot 10^{-4}$

Climatic category – 25/D

Θ_{min}	- 25 °C
Θ_{max}	+ 55 °C
Humidity	Average relative humidity $\leq 75 \%$
$t_{\text{LD(co)}}$	100000 h
Θ_{stg}	- 55 to + 70 °C

Remarks

Natural cooling
Delta connection
IEC 831-1/2, EN 60831-1/2, VDE 560-46/47

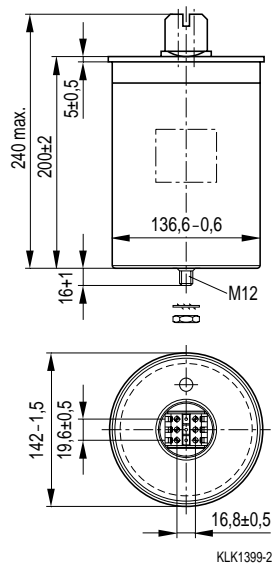

Design data

Dimensions $\varnothing \times l$	142 mm \times 200 mm
Approx. weight	2000 g
Impregnation	Gas
Fixing	Threaded bolt M12
Mounting hole	14 mm
Max. torque	10 Nm
Terminals	Safe-to-touch terminals
Max. torque	1,2 Nm
Terminal cross section	16 mm ²
Creepage distance	12,7 mm
Clearance	9,6 mm
Overpressure disconnecter	
Any mounting position	
Black painted case	

Thermal data

B25667-A4307-A365

Dielectric power dissipation P_D
versus repetition frequency f_0

$U_N = AC\ 440\ V$ —————
 $0,9 \cdot U_N = AC\ 396\ V$ - - - - -

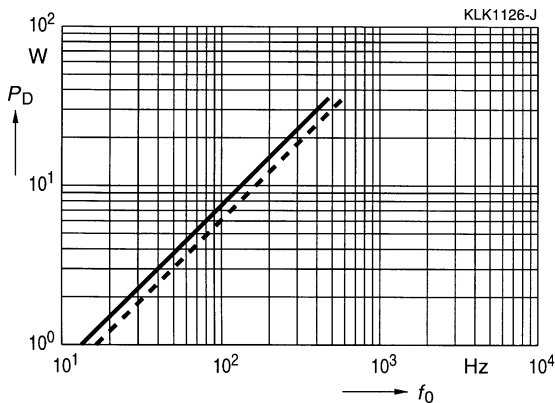

Ohmic power dissipation P_R
versus rms current value I

$R_S (70\ ^\circ C) = 13\ m\Omega$

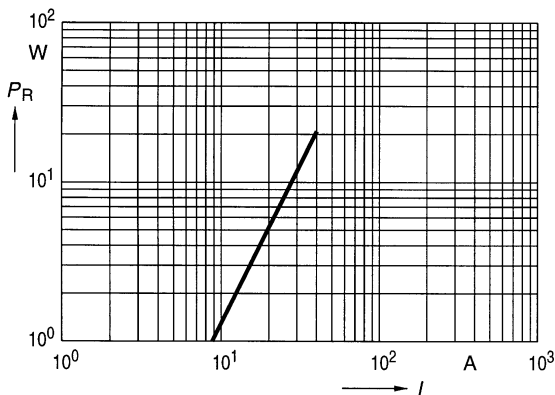

Permissible ambient temperature Θ_A
versus total power dissipation P

Natural cooling —————
Forced cooling 2 m/s - - - - -
Permissible capacitor
temperature - · - · - · -

black painted

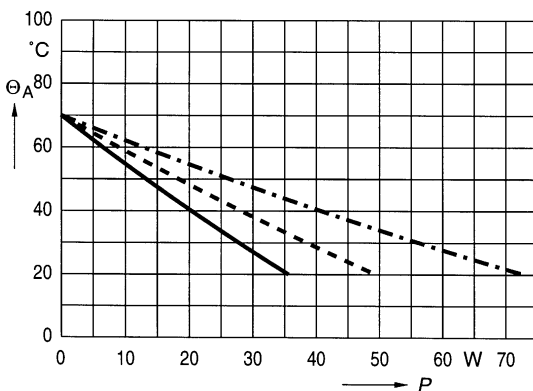

B 25 667

Power Factor Correction and Filtering

480 Vac / 3 ph / 25 kvar
 MKK-480-D-25-01

Ordering code: B25667-A4347-A365

Characteristics

C_N , tol.	$3 \times 115,2 \mu\text{F} +10/-5 \%$
Q_N	25 kvar
U_N	AC 480 V
f_N	50 Hz
I_N	$3 \times 30,1 \text{ A}$
$\tan \delta_0$	$2 \cdot 10^{-4}$

Maximum ratings

U_{max}	$1,1 \cdot U_N$, 8 h daily
I_{max}	$1,3 \cdot I_N$
I_s	$200 \cdot I_N$
$(du/dt)_{\text{max}}$	14 V/ μs
$(du/dt)_s$	35 V/ μs

Test data

U_{TT}	AC 1050 V, 10 s
U_{TC}	AC 3000 V, 50 Hz, 10 s
$\tan \delta$ (50 Hz)	$\leq 6 \cdot 10^{-4}$

Climatic category – 25/D

Θ_{min}	- 25 °C
Θ_{max}	+ 55 °C
Humidity	Average relative humidity $\leq 75 \%$
$t_{LD(\text{co})}$	100000 h
Θ_{stg}	- 55 to + 70 °C

Remarks

Natural cooling
 Delta connection
 IEC 831-1/2, EN 60831-1/2, VDE 560-46/47

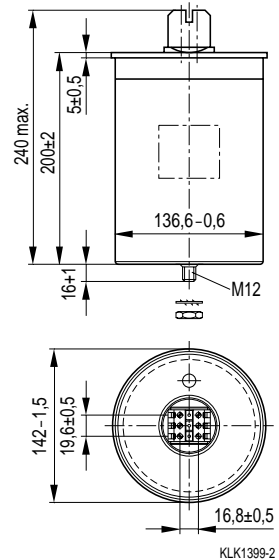

Design data

Dimensions $\varnothing \times l$	142 mm \times 200 mm
Approx. weight	2400 g
Impregnation	Gas
Fixing	Threaded bolt M12
Mounting hole	14 mm
Max. torque	10 Nm
Terminals	Safe-to-touch terminals
Max. torque	1,2 Nm
Terminal cross section	16 mm ²
Creepage distance	12,7 mm
Clearance	9,6 mm
Overpressure disconnecter	
Any mounting position	
Black painted case	

Thermal data

B25667-A4347-A365

Dielectric power dissipation P_D
versus repetition frequency f_0

$U_N = AC\ 480\ V$ —————
 $0,9 \cdot U_N = AC\ 432\ V$ - - - - -

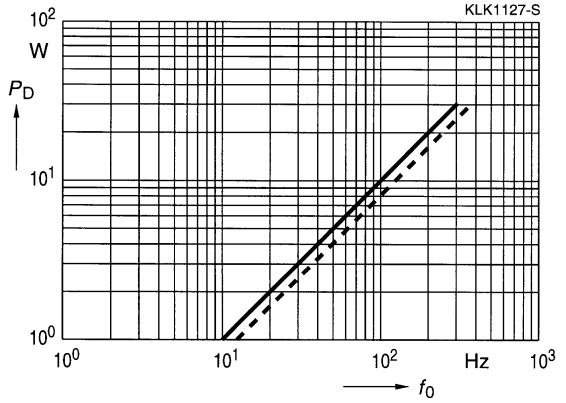

Ohmic power dissipation P_R
versus rms current value I

$R_S (70\ ^\circ C) = 10\ m\Omega$

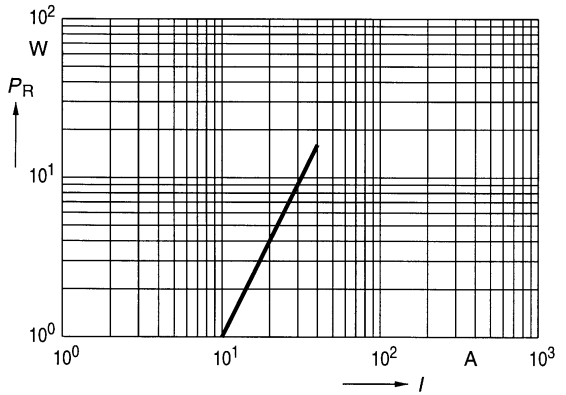

Permissible ambient temperature Θ_A
versus total power dissipation P

Natural cooling —————
Forced cooling 2 m/s - - - - -
Permissible capacitor
temperature - · - · - ·

black painted

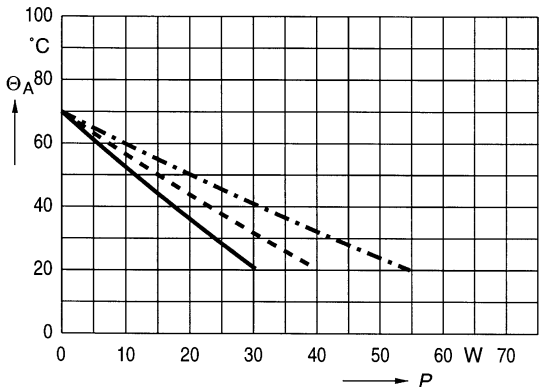

B 25 667

Power Factor Correction and Filtering

525 Vac / 3 ph / 25 kvar
 MKK-525-D-25-01

Ordering code: B25667-A5287-A375

Characteristics

C_N , tol.	$3 \times 96,3 \mu\text{F} +10/-5 \%$
Q_N	25 kvar
U_N	AC 525 V
f_N	50 Hz
I_N	$3 \times 27,5 \text{ A}$
$\tan \delta_0$	$2 \cdot 10^{-4}$

Maximum ratings

U_{max}	$1,1 \cdot U_N$, 8 h daily
I_{max}	$1,3 \cdot I_N$
I_s	$200 \cdot I_N$
$(du/dt)_{\text{max}}$	16 V/ μs
$(du/dt)_s$	40 V/ μs

Test data

U_{TT}	AC 1150 V, 10 s
U_{TC}	AC 3000 V, 50 Hz, 10 s
$\tan \delta$ (50 Hz)	$\leq 5 \cdot 10^{-4}$

Climatic category – 25/D

Θ_{min}	- 25 °C
Θ_{max}	+ 55 °C
Humidity	Average relative humidity $\leq 75 \%$
$t_{LD(\text{co})}$	100000 h
Θ_{stg}	- 55 to + 70 °C

Remarks

Natural cooling
 Delta connection
 IEC 831-1/2, EN 60831-1/2, VDE 560-46/47

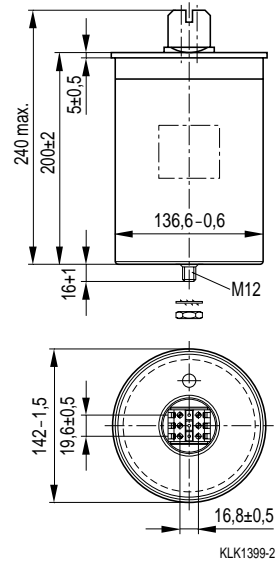

Design data

Dimensions $\varnothing \times l$	142 mm \times 200 mm
Approx. weight	2500 g
Impregnation	Gas
Fixing	Threaded bolt M12
Mounting hole	14 mm
Max. torque	10 Nm
Terminals	Safe-to-touch terminals
Max. torque	1,2 Nm
Terminal cross section	16 mm ²
Creepage distance	12,7 mm
Clearance	9,6 mm
Overpressure disconnecter	
Any mounting position	
Black painted case	

Thermal data

B25667-A5287-A375

Dielectric power dissipation P_D
versus repetition frequency f_0

$U_N = AC\ 525\ V$ —————
 $0,9 \cdot U_N = AC\ 473\ V$ - - - - -

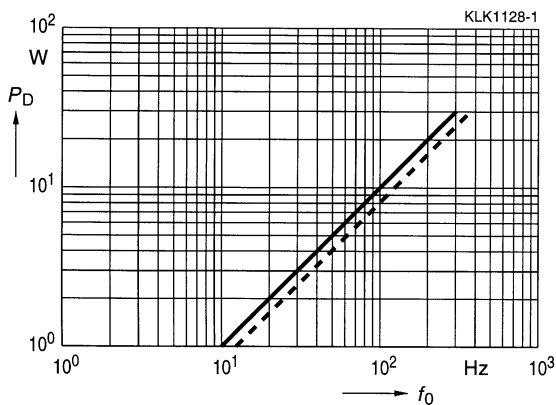

Ohmic power dissipation P_R
versus rms current value I

$R_S (70\ ^\circ C) = 11\ m\Omega$

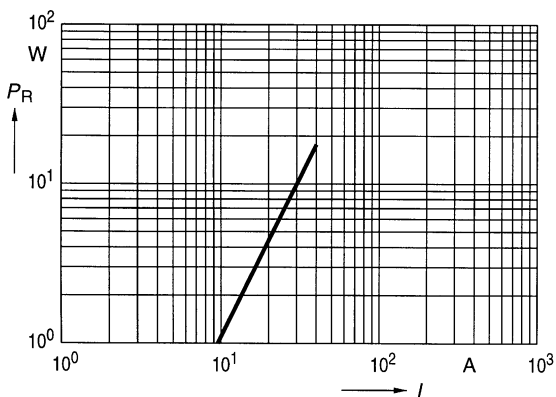

Permissible ambient temperature Θ_A
versus total power dissipation P

Natural cooling —————
Forced cooling 2 m/s - - - - -
Permissible capacitor
temperature - · - · - · -

black painted

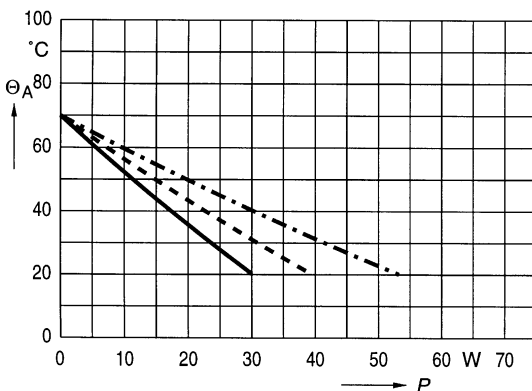

B 25 667

Power Factor Correction and Filtering

690 Vac / 3 ph / 25 kvar
 MKK-690-Y-25-01

Ordering code: B25667-A6507-A375

Characteristics

C_N , tol.	$3 \times 167,2 \mu\text{F} +10/-5 \%$
Q_N	25 kvar
U_N	AC 690 V
f_N	50 Hz
I_N	$3 \times 20,9 \text{ A}$
$\tan \delta_0$	$2 \cdot 10^{-4}$

Maximum ratings

U_{max}	$1,1 \cdot U_N$, 8 h daily
I_{max}	$1,3 \cdot I_N$
I_s	$200 \cdot I_N$
$(du/dt)_{\text{max}}$	20 V/ μs
$(du/dt)_s$	50 V/ μs

Test data

U_{TT}	AC 1500 V, 10 s
U_{TC}	AC 6000 V, 50 Hz, 10 s
$\tan \delta$ (50 Hz)	$\leq 6 \cdot 10^{-4}$

Climatic category – 25/D

Θ_{min}	- 25 °C
Θ_{max}	+ 55 °C
Humidity	Average relative humidity $\leq 75 \%$
$t_{LD(\text{co})}$	100000 h
Θ_{stg}	- 55 to + 70 °C

Remarks

Natural cooling
 Star connection
 IEC 831-1/2, EN 60831-1/2, VDE 560-46/47

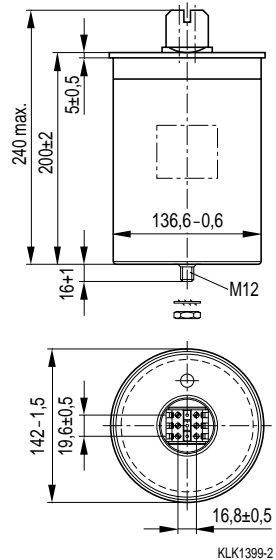

Design data

Dimensions $\varnothing \times l$	142 mm \times 200 mm
Approx. weight	2200 g
Impregnation	Gas
Fixing	Threaded bolt M12
Mounting hole	14 mm
Max. torque	10 Nm
Terminals	Safe-to-touch terminals
Max. torque	1,2 Nm
Terminal cross section	16 mm ²
Creepage distance	12,7 mm
Clearance	9,6 mm
Overpressure disconnecter	
Any mounting position	
Black painted case	

Thermal data

B25667-A6507-A375

Dielectric power dissipation P_D
versus repetition frequency f_0

$U_N = \text{AC } 690 \text{ V}$ —————
 $0,9 \cdot U_N = \text{AC } 621 \text{ V}$ - - - - -

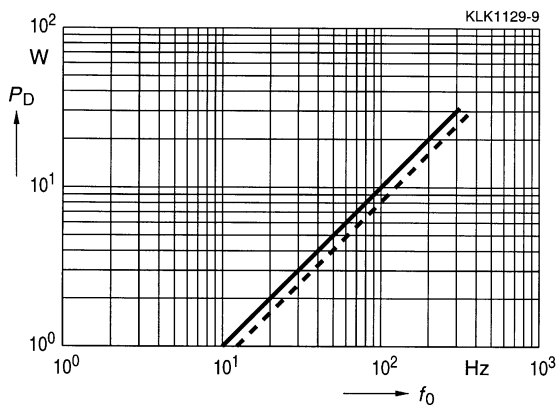

Ohmic power dissipation P_R
versus rms current value I

$R_S (70 \text{ }^\circ\text{C}) = 24 \text{ m}\Omega$

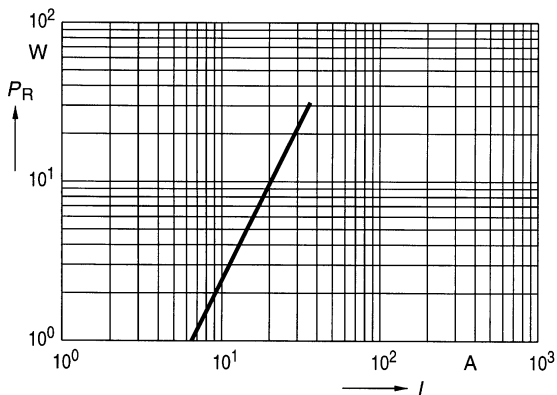

Permissible ambient temperature Θ_A
versus total power dissipation P

Natural cooling —————
Forced cooling 2 m/s - - - - -
Permissible capacitor
temperature - · - · - ·

black painted

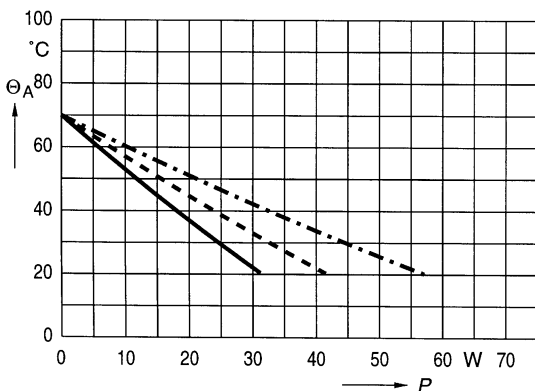

B 25 667

Power Factor Correction and Filtering

230 Vac / 1 ph / 5,2 kvar
MKK-230-I-05-01

Ordering code: B25667-A2317-A175

Characteristics

C_N , tol.	$1 \times 313 \mu\text{F} +10/-5 \%$
Q_N	5,2 kvar
U_N	AC 230 V
f_N	50 Hz
I_N	22,6 A
$\tan \delta_0$	$2 \cdot 10^{-4}$

Maximum ratings

U_{max}	$1,1 \cdot U_N$, 8 h daily
I_{max}	$1,3 \cdot I_N$
I_s	$200 \cdot I_N$
$(du/dt)_{\text{max}}$	10 V/ μs
$(du/dt)_s$	25 V/ μs

Test data

U_{TT}	AC 500 V, 10 s
U_{TC}	AC 3000 V, 50 Hz, 10 s
$\tan \delta$ (50 Hz)	$\leq 6 \cdot 10^{-4}$

Climatic category – 25/D

Θ_{min}	- 25 °C
Θ_{max}	+ 55 °C
Humidity	Average relative humidity $\leq 75 \%$
$t_{LD(\text{co})}$	100000 h
Θ_{stg}	- 55 to + 70 °C

Remarks

Natural cooling
IEC 831-1/2, EN 60831-1/2, VDE 560-46/47

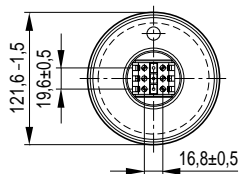
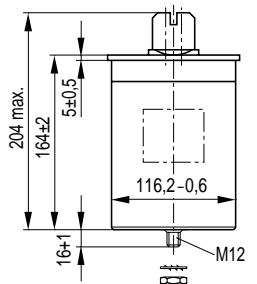

KLK1397-K

Design data

Dimensions $\varnothing \times l$	121,6 mm \times 164 mm
Approx. weight	1100 g
Impregnation	Gas
Fixing	Threaded bolt M12
Mounting hole	14 mm
Max. torque	10 Nm
Terminals	Safe-to-touch terminals
Max. torque	1,2 Nm
Terminal cross section	16 mm ²
Creepage distance	12,7 mm
Clearance	9,6 mm
Overpressure disconnecter	
Any mounting position	
Black painted case	

Thermal data

B25667-A2317-A175

Dielectric power dissipation P_D
 versus repetition frequency f_0

$U_N = \text{AC } 230 \text{ V}$ —————
 $0,9 \cdot U_N = \text{AC } 207 \text{ V}$ - - - - -

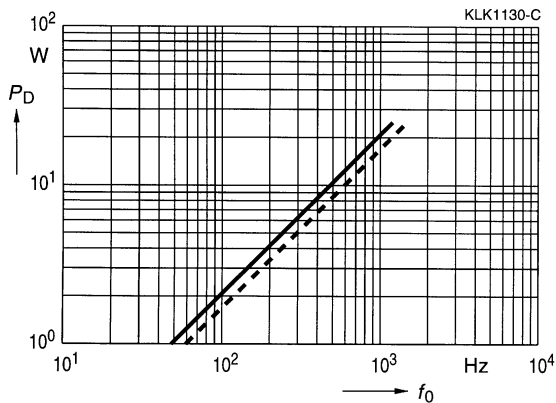

Ohmic power dissipation P_R
 versus rms current value I

$R_S (70 \text{ }^\circ\text{C}) = 4,7 \text{ m}\Omega$

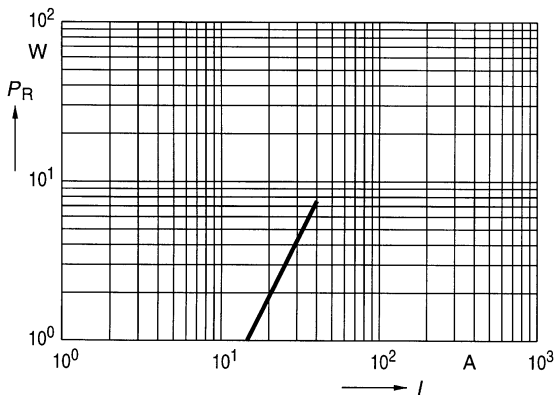

Permissible ambient temperature Θ_A
 versus total power dissipation P

Natural cooling —————
 Forced cooling 2 m/s - - - - -
 Permissible capacitor
 temperature - · - · - ·

black painted

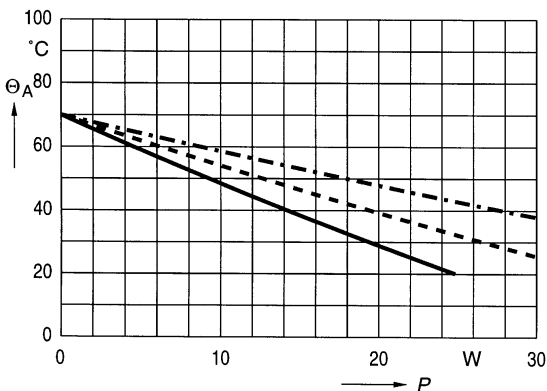

B 25 667

Power Factor Correction and Filtering

400 Vac / 1 ph / 12,5 kvar
MKK-400-I-12,5-01

Ordering code: B25667-A3247-A175

Characteristics

C_N , tol.	$1 \times 249 \mu\text{F} +10/-5 \%$
Q_N	12,5 kvar
U_N	AC 400 V
f_N	50 Hz
I_N	31,3 A
$\tan \delta_0$	$2 \cdot 10^{-4}$

Maximum ratings

U_{max}	$1,1 \cdot U_N$, 8 h daily
I_{max}	$1,3 \cdot I_N$
I_s	$200 \cdot I_N$
$(du/dt)_{\text{max}}$	14 V/ μs
$(du/dt)_s$	35 V/ μs

Test data

U_{TT}	AC 860 V, 10 s
U_{TC}	AC 3000 V, 50 Hz, 10 s
$\tan \delta$ (50 Hz)	$\leq 5 \cdot 10^{-4}$

Climatic category – 25/D

Θ_{min}	- 25 °C
Θ_{max}	+ 55 °C
Humidity	Average relative humidity $\leq 75 \%$
$t_{LD(\text{co})}$	100000 h
Θ_{stg}	- 55 to + 70 °C

Remarks

Natural cooling
IEC 831-1/2, EN 60831-1/2, VDE 560-46/47

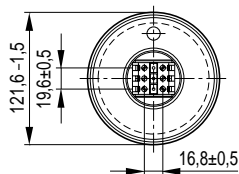
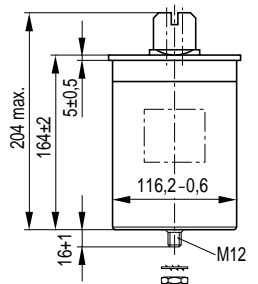

KLK1397-K

Design data

Dimensions $\varnothing \times l$	121,6 mm \times 164 mm
Approx. weight	1300 g
Impregnation	Gas
Fixing	Threaded bolt M12
Mounting hole	14 mm
Max. torque	10 Nm
Terminals	Safe-to-touch terminals
Max. torque	1,2 Nm
Terminal cross section	16 mm ²
Creepage distance	12,7 mm
Clearance	9,6 mm
Overpressure disconnecter	
Any mounting position	
Black painted case	

Thermal data

B25667-A3247-A175

Dielectric power dissipation P_D
versus repetition frequency f_0

$U_N = AC\ 400\ V$ —————
 $0,9 \cdot U_N = AC\ 360\ V$ - - - - -

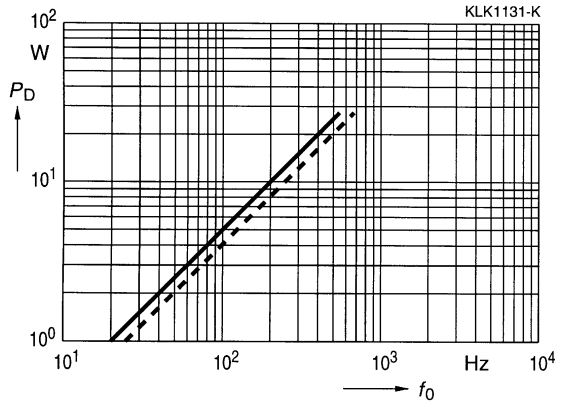

Ohmic power dissipation P_R
versus rms current value I

$R_S (70\ ^\circ C) = 4,4\ m\Omega$

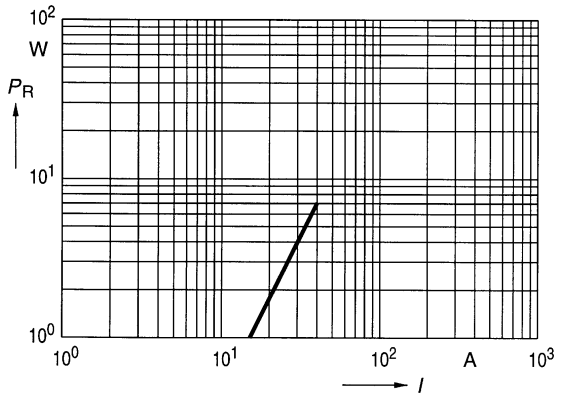

Permissible ambient temperature Θ_A
versus total power dissipation P

Natural cooling —————
Forced cooling 2 m/s - - - - -
Permissible capacitor
temperature - · - · - ·

black painted

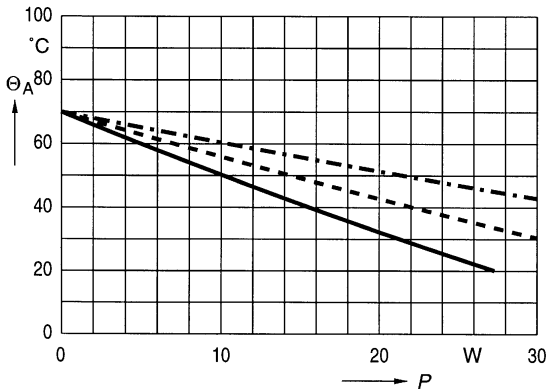

B 25 667

Power Factor Correction and Filtering

525 Vac / 1 ph / 15 kvar
 MKK-525-I-15-01

Ordering code: B25667-A5177-A175

Characteristics

C_N , tol.	$1 \times 173 \mu\text{F} +10/-5 \%$
Q_N	15 kvar
U_N	AC 525 V
f_N	50 Hz
I_N	28,5 A
$\tan \delta_0$	$2 \cdot 10^{-4}$

Maximum ratings

U_{max}	$1,1 \cdot U_N$, 8 h daily
I_{max}	$1,3 \cdot I_N$
I_s	$200 \cdot I_N$
$(du/dt)_{\text{max}}$	16 V/ μs
$(du/dt)_s$	40 V/ μs

Test data

U_{TT}	AC 1150 V, 10 s
U_{TC}	AC 3000 V, 50 Hz, 10 s
$\tan \delta$ (50 Hz)	$\leq 5 \cdot 10^{-4}$

Climatic category – 25/D

Θ_{min}	- 25 °C
Θ_{max}	+ 55 °C
Humidity	Average relative humidity $\leq 75 \%$
$t_{LD(\text{co})}$	100000 h
Θ_{stg}	- 55 to + 70 °C

Remarks

Natural cooling
 IEC 831-1/2, EN 60831-1/2, VDE 560-46/47

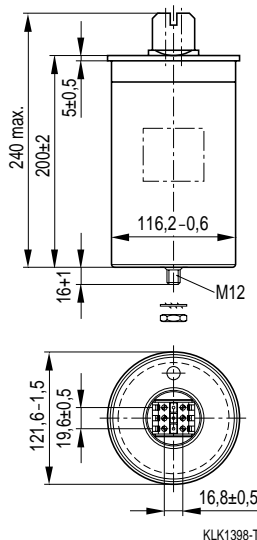

Design data

Dimensions $\varnothing \times l$	121,6 mm \times 200 mm
Approx. weight	1700 g
Impregnation	Gas
Fixing	Threaded bolt M12
Mounting hole	14 mm
Max. torque	10 Nm
Terminals	Safe-to-touch terminals
Max. torque	1,2 Nm
Terminal cross section	16 mm ²
Creepage distance	12,7 mm
Clearance	9,6 mm
Overpressure disconnecter	
Any mounting position	
Black painted case	

Thermal data

B25667-A5177-A175

Dielectric power dissipation P_D
versus repetition frequency f_0

$U_N = AC\ 525\ V$ —————
 $0,9 \cdot U_N = AC\ 473\ V$ - - - - -

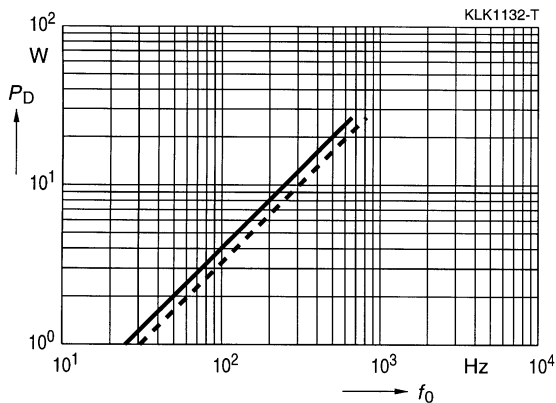

Ohmic power dissipation P_R
versus rms current value I

$R_S (70\ ^\circ C) = 6,8\ m\Omega$

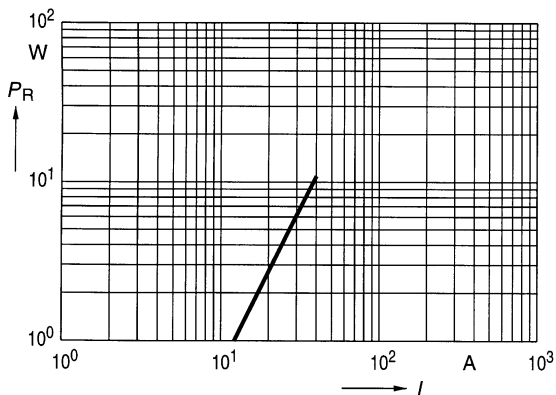

Permissible ambient temperature Θ_A
versus total power dissipation P

Natural cooling —————
Forced cooling 2 m/s - - - - -
Permissible capacitor
temperature - · - · - · -

black painted

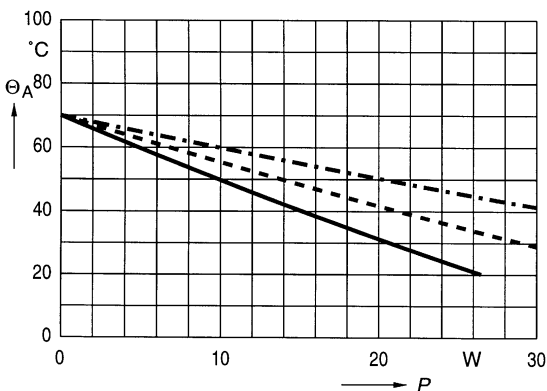

SIEMENS

Now order even more

We've really got things in store

When you need bigger batches than usual, we don't leave you with empty hands. We've pushed up maximum order quantities quite a bit, all of ten times for ceramic chip capacitors for example. But we've got lots more in



store for you, like SCS depots right there in our plants, extra stock with distributors, and experienced sales engineers on the spot around the world. An extensive range of non-SCS components is available too – just contact us.

SCS – dependable, fast and competent

