

# MBR3020CT THRU MBR30200CT

## SCHOTTKY BARRIER RECTIFIER

Reverse Voltage - 20 to 200 Volts Forward Current - 30Amperes



### FEATURES

- Plastic package has Underwriters Laboratory Flammability Classification 94V-0
- Metal silicon junction ,majority carrier conduction
- Guard ring for overvoltage protection
- Low power loss ,high efficiency
- High current capability ,Low forward voltage drop
- Single rectifier construction
- High surge capability
- For use in low voltage ,high frequency inverters, free wheeling ,and polarity protection applications
- High temperature soldering guaranteed:260°C/10 seconds, 0.25"(6.35mm)from case
- Component in accordance to RoHS 2002/95/EC and WEEE 2002/96/EC



### TO-220AB

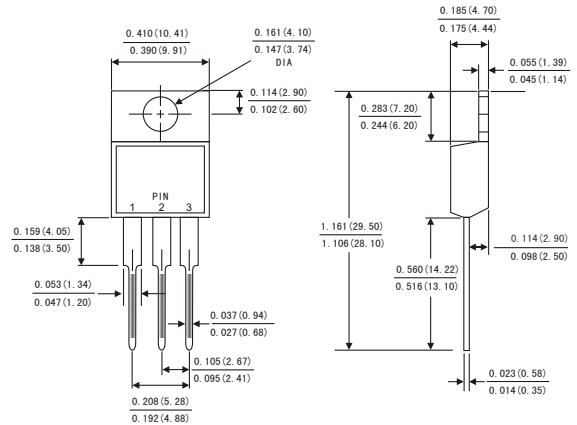

Dimensions in inches and (millimeters)

### MECHANICAL DATA

- Case: JEDEC TO-220AB molded plastic body
- Terminals: Lead solderable per MIL-STD-750,method 2026
- Polarity: As marked
- Mounting Position: Any
- Weight: 0.08ounce, 2.24 grams

### MAXIMUM RATINGS AND ELECTRICAL CHARACTERISTICS

(Ratings at 25°C ambient temperature unless otherwise specified ,Single phase ,half wave ,resistive or inductive load. For capacitive load,derate by 20%.)

	Symbols	MBR 3020CT	MBR 3030CT	MBR 3040CT	MBR 3045CT	MBR 3060CT	MBR 3080CT	MBR 30100CT	MBR 30150CT	MBR 30200CT	Units
Maximum repetitive peak reverse voltage	V <sub>RRM</sub>	20	30	40	45	60	80	100	150	200	Volts
Maximum RMS voltage	V <sub>RMS</sub>	14	21	28	32	42	56	70	105	140	Volts
Maximum DC blocking voltage	V <sub>DC</sub>	20	30	40	45	60	80	100	150	200	Volts
Maximum average forward rectified current(see Fig.1)	Per leg	15.0 30.0									Amps
	Total device										
Peak forward surge current 8.3ms single half sine-wave superimposed on rated load (JEDEC method)	I <sub>FSM</sub>	250.0									Amps
Maximum instantaneous forward voltage at 30.0 A	V <sub>F</sub>	0.60			0.75	0.85		0.95			Volts
Maximum instantaneous reverse current at rated DC blocking voltage(Note 1)	T <sub>c</sub> = 25°C	0.2									mA
	T <sub>c</sub> = 125°C	30			50						
Typical thermal resistance (Note 2)	R <sub>θJC</sub>	3.0									°C/W
Operating junction temperature range	T <sub>J</sub>	-65 to +150									°C
Storage temperature range	T <sub>STG</sub>	-65 to +150									°C

- Notes: 1.Pulse test: 300 μs pulse width,1% duty cycle  
2.Thermal resistance from junction to case

# MBR3020CT THRU MBR30200CT

## SCHOTTKY BARRIER RECTIFIER

Reverse Voltage - 20 to 200 Volts Forward Current - 30Amperes



FIG.1-FORWARD CURRENT DERATING CURVE

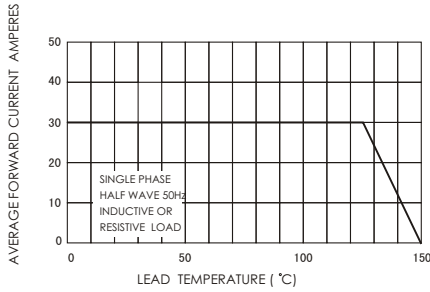

FIG.2-MAXIMUM NON-REPETITIVE PEAK FORWARD SURGE CURRENT PER DIODE

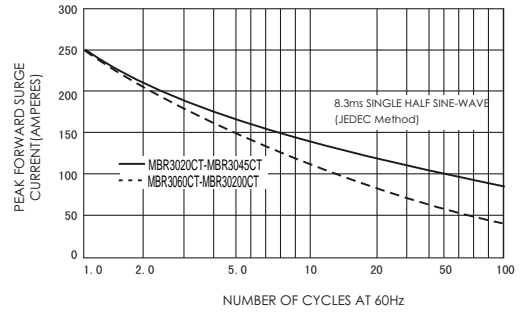

FIG.3-TYPICAL INSTANTANEOUS FORWARD CHARACTERISTICS

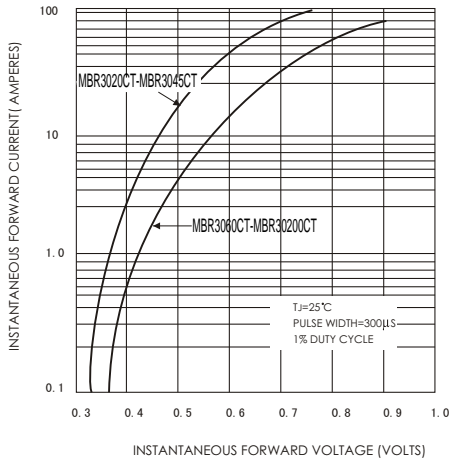

FIG.4-TYPICAL REVERSE CHARACTERISTICS

