

LM25056A

System Power Measurement IC with PMBus™

General Description

The LM25056A combines high performance analog and digital technology with a PMBus™ compliant SMBus™/I²C interface to accurately measure the operating conditions of electrical systems including computing and storage blades connected to a backplane power bus. The LM25056A continuously supplies real-time power, voltage, current, and temperature data to the system management host via the SMBus interface.

The LM25056A monitoring block captures both real-time and average values of subsystem operating parameters (V_{IN} , I_{IN} , P_{IN} , V_{AUX}) as well as peak power. Accurate power measurement is accomplished by measuring the product of the input voltage and current through a shunt resistor. LM25056A current measurement has a $\pm 0.5\%$ accuracy over the temperature range of $+10^{\circ}\text{C}$ to $+85^{\circ}\text{C}$ with operation from -40°C to $+125^{\circ}\text{C}$. A black box (Telemetry/Fault Snapshot) function captures and stores telemetry data and device status in the event of a warning or a fault.

PMBus is a trademark of SMIF, Inc. SMBus is a trademark of Intel Corp.

Features

- Input voltage range: 3V to 17V
- I²C/SMBus™ interface with PMBus compliant command structure
- Remote temperature sensing with programmable warning and shutdown thresholds
- Real time monitoring of V_{IN} , I_{IN} , P_{IN} , V_{AUX} with 12-bit resolution and 1 kHz sampling rate
- Current measurement error: $\pm 0.5\%$: $+10^{\circ}\text{C}$ to $+85^{\circ}\text{C}$
- Voltage measurement error: $\pm 1.0\%$: $+10^{\circ}\text{C}$ to $+85^{\circ}\text{C}$
- Power measurement error: $\pm 1.5\%$: $+10^{\circ}\text{C}$ to $+85^{\circ}\text{C}$
- True input power measurement using simultaneous sampling of V_{IN} and I_{IN} accurately averages dynamic power readings
- Averaging of V_{IN} , I_{IN} , P_{IN} , and V_{AUX} over programmable interval ranging from 0.001 to 4 seconds
- User programmable WARN and FAULT thresholds with $\overline{\text{SMBA}}$ notification
- Black box capture of telemetry measurements and device status triggered by WARN and FAULT conditions
- Full featured application development software
- LLP-24 package

Applications

- Server backplane systems
- Base station power distribution systems
- Subsystem power measurement

Typical Application Schematic

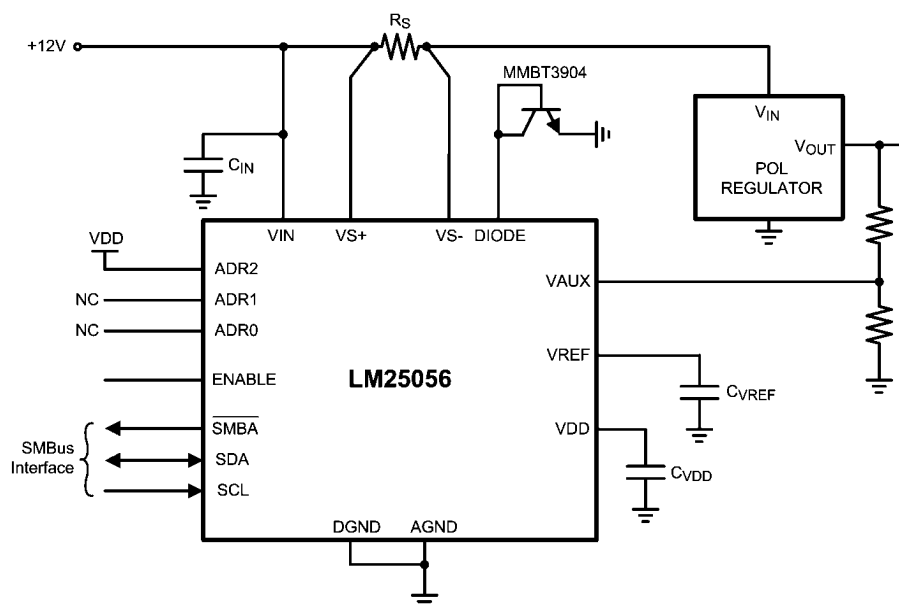

30180001

Connection Diagram

Solder exposed pad to ground.

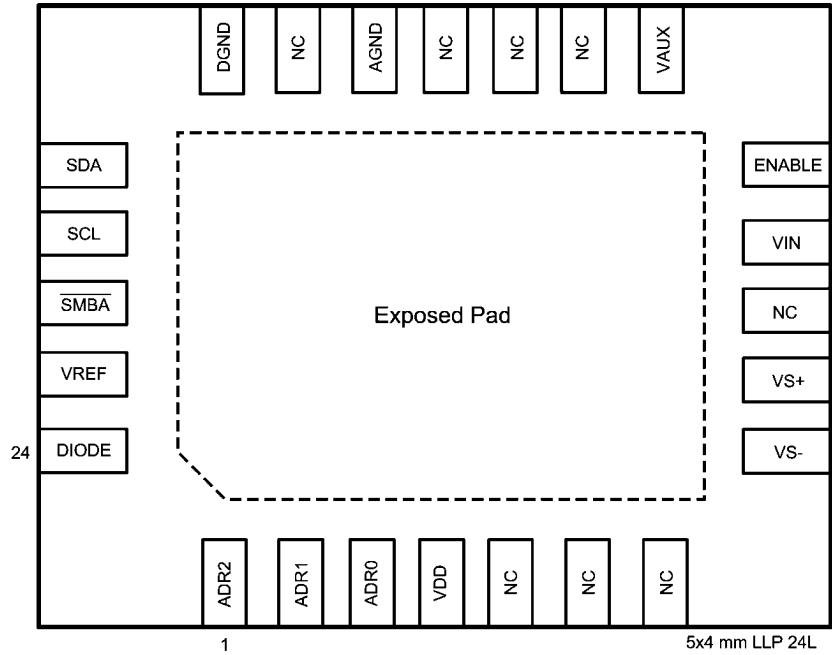

Top View
LLP-24

30180002

Ordering Information

Order Number	Package Type	Package Drawing	Supplied As
LM25056APSQ	LLP-24	SQA24B	1,000 units in tape and reel
LM25056APSQE	LLP-24	SQA24B	250 units in tape and reel
LM25056APSQX	LLP-24	SQA24B	4,500 units in tape and reel

Pin Descriptions

Pin No.	Name	Description	Applications Information
PAD	Exposed Pad	Exposed pad of LLP package	No internal electrical connections. Solder to the ground plane to reduce thermal resistance.
1	ADR2	SMBus address line 2	3 - state address line. Should be connected to GND, VDD, or left floating.
2	ADR1	SMBus address line 1	3 - state address line. Should be connected to GND, VDD, or left floating.
3	ADR0	SMBus address line 0	3 - state address line. Should be connected to GND, VDD, or left floating.
4	VDD	Internal sub-regulator output	Internally sub-regulated 3.7V bias supply. Connect a 1 μ F capacitor on this pin to ground for bypassing. VDD can be driven from an external voltage for low voltage operation.
5	NC	No Connect	Not bonded to die. Can be connected to the ground plane.
6	NC	No Connect	Not bonded to die. Can be connected to the ground plane.
7	NC	No Connect	Not bonded to die. Can be connected to the ground plane.
8	VS-	Current sense input (-)	Negative IIN sense amplifier input. The voltage across the current sense resistor (R_S) is measured from VS+ to this pin.
9	VS+	Current sense input (+)	Positive IIN sense amplifier input. The voltage across the current sense resistor (R_S) is measured from this pin to VS-.
10	NC	No Connect	Not bonded to die. Can be connected to the ground plane.
11	VIN	Positive supply input	A small 0.1 μ F ceramic bypass capacitor close to this pin is recommended. VIN is measured from this pin.
12	ENABLE	Enable	Enable pin. This pin has a rising threshold of +1.2V to enable the LM25056A. Lowering this pin below the 75mV hysteresis from the +1.2V threshold will put the part into power down mode.
13	VAUX	Auxiliary voltage input	Auxiliary pin allows voltage telemetry from an external source. Full scale input of 1.2V
14	NC	No Connect	Not bonded to die. Can be connected to the ground plane.
15	NC	No Connect	Not bonded to die. Can be connected to the ground plane.
16	NC	No Connect	Not bonded to die. Can be connected to the ground plane.
17	AGND	Analog ground	Connect analog ground to digital ground and then to a quiet system ground. Be sure to avoid high current return ground lines.
18	NC	No Connect	Not bonded to die. Can be connected to the ground plane.
19	DGND	Digital ground	Connect analog ground to digital ground and then to a clean system ground. Be sure to avoid high current return ground lines.
20	SDA	SMBus data pin	Data pin for SMBus.
21	SCL	SMBus clock	Clock pin for SMBus.
22	$\overline{\text{SMBA}}$	SMBus alert line	Alert pin for SMBus. Active low.
23	VREF	Internal reference	Internally generated precision 2.82V reference used for analog to digital conversion. Connect a 1 μ F ceramic capacitor on this pin to ground for bypassing.
24	DIODE	External diode	Connect this to a diode-configured MMBT3904 NPN transistor for temperature monitoring.

Absolute Maximum Ratings (Note 1)

If Military/Aerospace specified devices are required, please contact the Texas Instruments Sales Office/ Distributors for availability and specifications.

VIN, VS-, VS+ to AGND/DGND	-0.3V to 24V
SCL, SDA, SMBA, ADR0, ADR1, ADR2, VDD, VAUX, DIODE, ENABLE to AGND/DGND	-0.3V to 6V
VS+ to VS-	-0.3V to +0.3V
ESD Rating (Note 2)	2kV
Human Body Model	

Storage Temperature	-65°C to +150°C
Junction Temperature	+150°C

Operating Ratings

VIN, VS-, VS+ voltage	3V to 17V
VDD	3V to 5.5V
Junction Temperature	-40°C to +125°C

Electrical Characteristics Limits in standard type are for $T_J = +25^\circ\text{C}$ only; limits in boldface type apply over the junction temperature (T_J) range of -40°C to $+85^\circ\text{C}$ unless otherwise stated. Minimum and Maximum limits are guaranteed through test, design, or statistical correlation. Typical values represent the most likely parametric norm at $T_J = +25^\circ\text{C}$, and are provided for reference purposes only. Unless otherwise stated the following conditions apply: $V_{IN} = 12\text{V}$. See (Note 3) and (Note 4).

Symbol	Parameter	Conditions	Min.	Typ.	Max.	Units
Input (VIN Pin)						
$I_{\text{SUPPLY-EN}}$	Supply current, enabled	ENABLE > 1.2V		1.7	2.8	mA
$I_{\text{SUPPLY-DIS}}$	Supply current, disabled	ENABLE < 1.2V		10	100	μA
VREF Reference						
VREF	Reference voltage			2.82		V
VDD Regulator (VDD pin)						
VDD			3.1	3.7	4.1	V
I_{VDDLIM}	VDD current limit	$V_{IN} = 12\text{V}$		50		mA
POR_{VDD}	Power on reset threshold at VDD	VDD increasing		2.4	3.0	V
POR_{HYS}	POR hysteresis	VDD decreasing		90		mV
ADC and MUX						
Resolution				12		Bits
t_{RR}	Acquisition round robin time	Update all telemetry channels		1		ms
Telemetry Accuracy						
I_{INIB}	Current sense input bias current			20		μA
I_{INFSR}	Current sense full scale range, $V_{\text{SENSE}} = \text{VS+} - \text{VS-}$	GAIN = 0		29.68		mV
		GAIN = 1		60.88		mV
I_{INLSB}	Current sense input LSB	GAIN = 0		7.25		μV
		GAIN = 1		14.87		μV
VAUX_{FSR}	VAUX input full scale range (ADC native range)			1.199		V
VAUX_{LSB}	VAUX input LSB			293		μV
VIN_{FSR}	Supply voltage measurement full scale range	For calculation only, observe maximum voltage ratings.		25.13		V
VIN_{LSB}	Supply voltage measurement LSB			6.14		mV
I_{INERR}	Current sense measurement error	GAIN = 0, $V_{\text{SENSE}} = 25\text{ mV}$, $+10^\circ\text{C}$ to $+85^\circ\text{C}$	-0.5		+0.5	%
I_{INERR}	Current sense measurement error	GAIN = 0, $V_{\text{SENSE}} = 25\text{ mV}$	-1.5		+1.5	%
I_{INERR}	Current sense measurement error	GAIN = 0, $V_{\text{SENSE}} = 5\text{ mV}$, $+10^\circ\text{C}$ to $+85^\circ\text{C}$	-5		+5	%
I_{INERR}	Current sense measurement error	GAIN = 1, $V_{\text{SENSE}} = 55\text{ mV}$,		1		%
P_{ERR}	Input power measurement error	GAIN = 0, $V_{IN} = 12\text{V}$, $V_{\text{SENSE}} = 25\text{ mV}$, $+10^\circ\text{C}$ to $+85^\circ\text{C}$	-1.5		+1.5	%
P_{ERR}	Input power measurement error	GAIN = 0, $V_{IN} = 12\text{V}$, $V_{\text{SENSE}} = 25\text{ mV}$	-3		+3	%
P_{ERR}	Input power measurement error	GAIN = 1, $V_{IN} = 12\text{V}$, $V_{\text{SENSE}} = 55\text{ mV}$		2		%
VIN_{ERR}	Input voltage measurement error	$V_{IN} = 12\text{V}$, $+10^\circ\text{C}$ to $+85^\circ\text{C}$	-1.0		+1.0	%

Symbol	Parameter	Conditions	Min.	Typ.	Max.	Units
V _{INERR}	Input voltage measurement error	V _{IN} = 12V	-1.5		+1.5	%
V _{AUXERR}	Auxiliary measurement error	V _{AUX} = 1V, +10°C to +85C	-1.5		+1.5	%
V _{AUXERR}	Auxiliary measurement error	V _{AUX} = 1V	-2.5		+2.5	%
Remote Diode Temperature Sensor						
T _{ACC}	Temperature accuracy using local diode			3		°C
	Remote diode resolution			9		bits
I _{DIODE}	External diode current source	High Level		240	325	μA
		Low Level		9.2		μA
Diode Current Ratio				26		
PMBus Pin Thresholds ($\overline{\text{SMBA}}$, SDA, SCL)						
V _{IL}	Data, clock input low voltage				0.9	V
V _{IH}	Data, clock input high voltage		2.1		5.5	V
V _{OL}	Data output low voltage	I _{PULLUP} = 5 mA	0		0.4	V
I _{LEAK}	Input leakage current	SDA, $\overline{\text{SMBA}}$, SCL = 5.5V			1	μA
ENABLE Pin						
V _{EN}	ENABLE threshold voltage	Rising threshold	1.4	1.2		V
V _{EN-HYS}	ENABLE threshold voltage hysteresis			75		mV
I _{LEAK}	Input Leakage Current	ENABLE = 5V			1	mA
I _{PULLUP}	ENABLE pin pullup current			2.8		μA

Note 1: Absolute Maximum Ratings indicate limits beyond which damage to the device may occur. Operating Ratings indicate conditions for which the device is intended to be functional, but do not guarantee specific performance limits. For guaranteed specifications and conditions see the Electrical Characteristics.

Note 2: The human body model is a 100 pF capacitor discharged through a 1.5 kΩ resistor into each pin.

Note 3: Current out of a pin is indicated as a negative value.

Note 4: All limits are guaranteed. All electrical characteristics having room temperature limits are tested during production at T_A = +25°C. All bold limits are guaranteed by correlating the electrical characteristics to process and temperature variations and applying statistical process control.

Typical Performance Characteristics Unless otherwise specified the following conditions apply: $T_J = +25^\circ\text{C}$, $V_{IN} = 12\text{V}$. All graphs show junction temperature.

VIN Pin Current (Enabled)

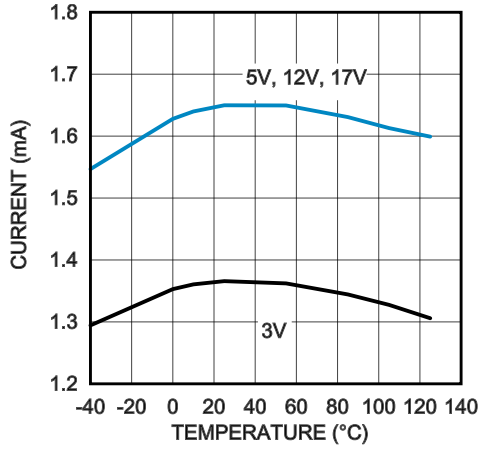

30180071

VIN Pin Current (Disabled)

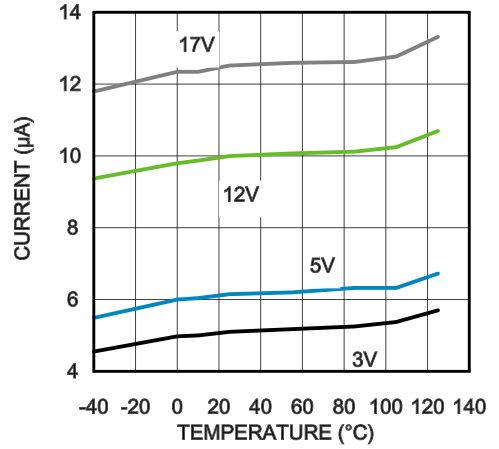

30180079

VS+ Pin Input Bias Current (Enabled)

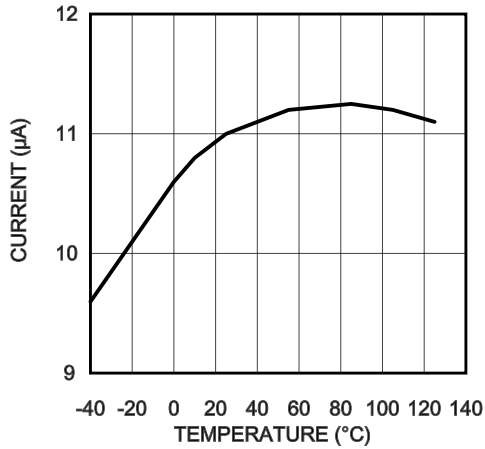

30180076

VS- Pin Input Bias Current (Enabled)

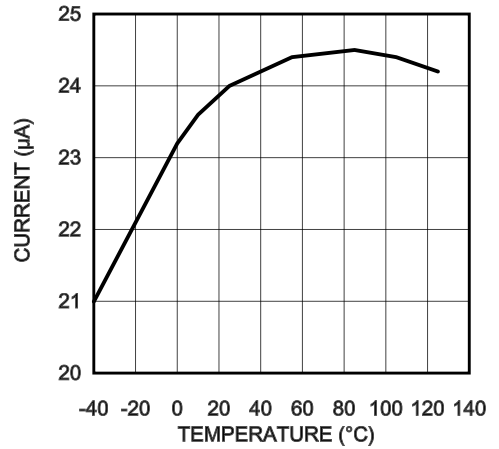

30180075

POR Threshold

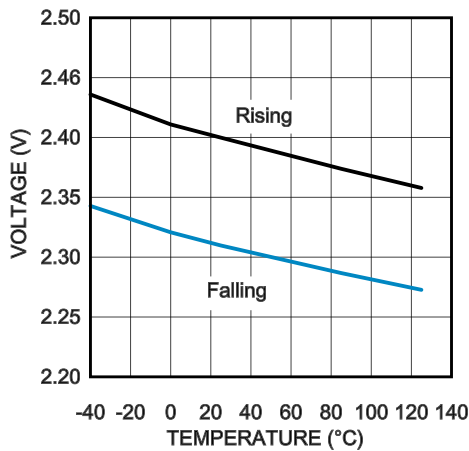

301800a13

ENABLE Threshold

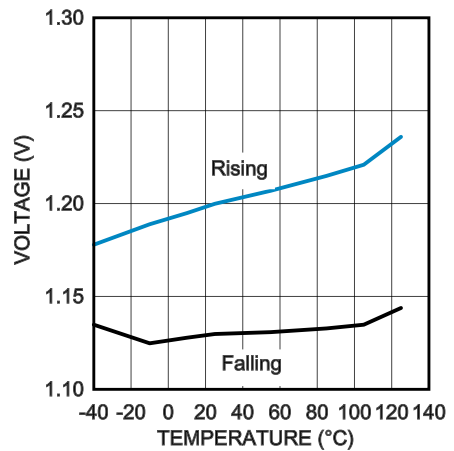

301800a14

VREF Voltage

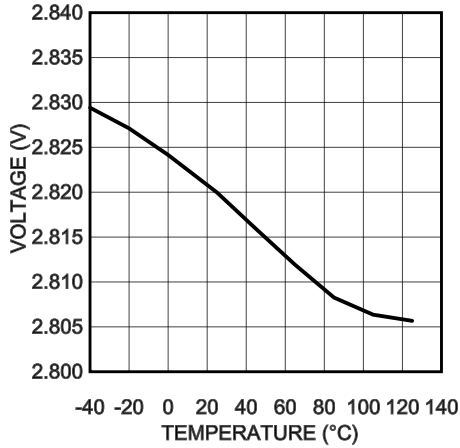

30180072

VDD Voltage

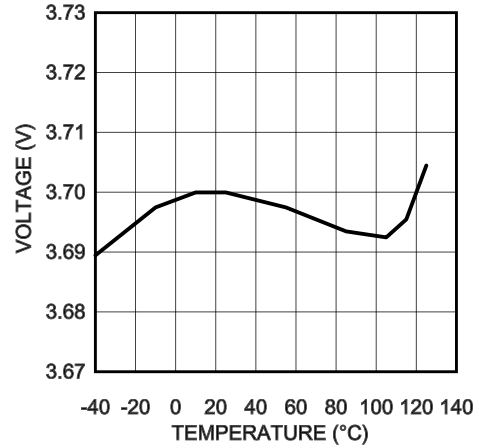

30180089

VIN Error, VIN=12V

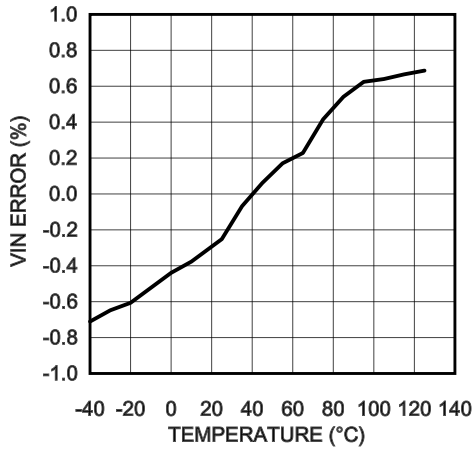

30180080

VAUX Error, VAUX=1V

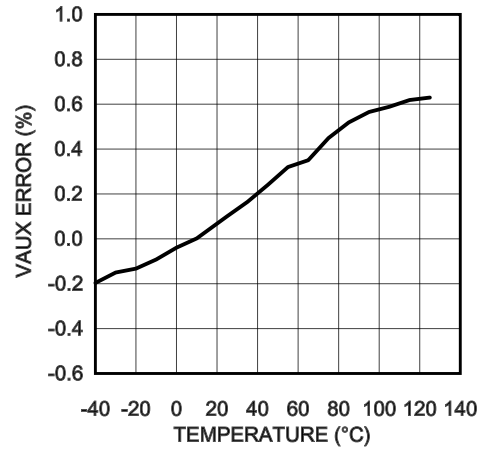

30180081

IIN Error, GAIN=0, V_{SENSE}=25mV

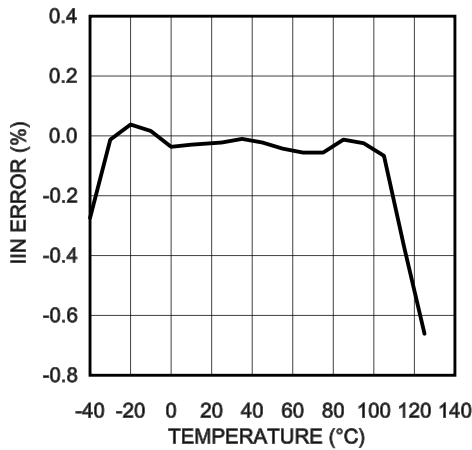

30180073

PIN Error, GAIN=0, VIN=12V, V_{SENSE}=25mV

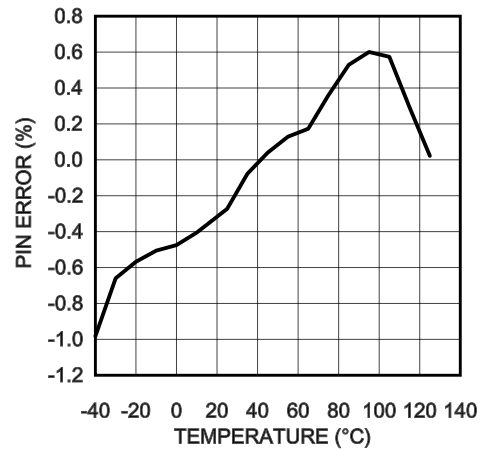

30180074

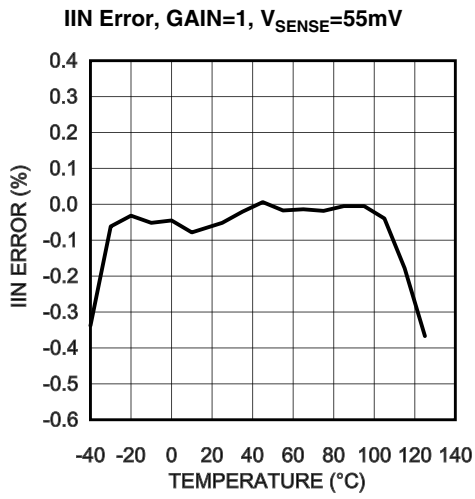

30180077

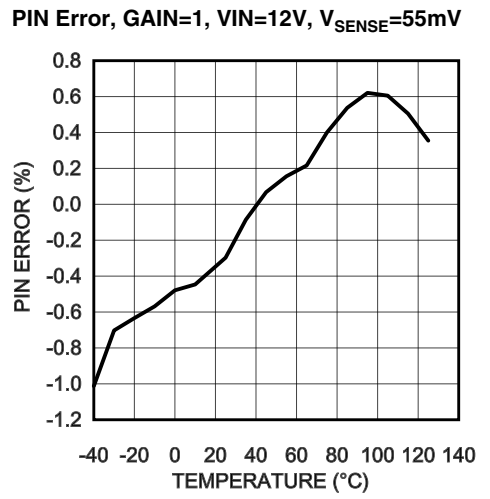

30180078

Block Diagram

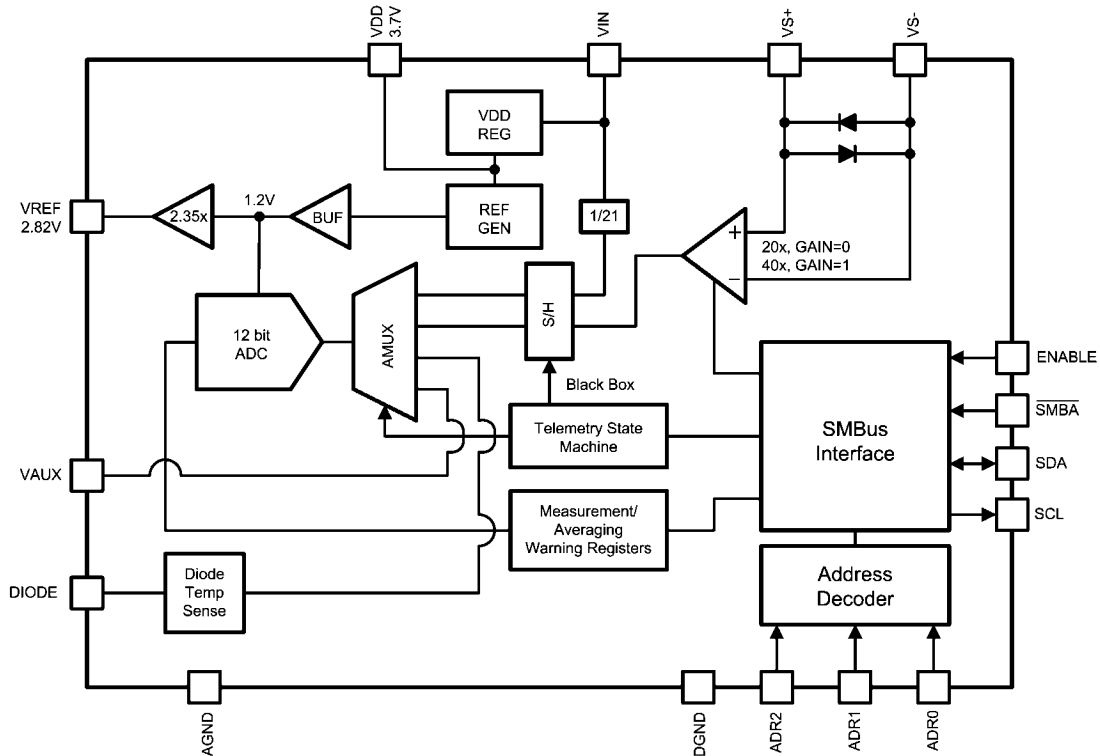

30180010

Functional Description

The LM25056A provides intelligent monitoring of the input voltage, input current, input power, temperature, and an auxiliary input. The LM25056A also provides a peak capture of the input power and programmable hardware averaging of the input voltage, current, power, temperature, and the auxiliary voltage. Warning thresholds which trigger the SMBA pin may be programmed for input and auxiliary voltage, current, power, and temperature via the PMBus interface.

Enabling/Disabling and Resetting

The LM25056A has an ENABLE pin that can be used to power on and off the device. If desired, the LM25056A can be kept in shutdown until the supply reaches a particular threshold using ENABLE with a resistor divider or with an active control as shown in Figure 1.

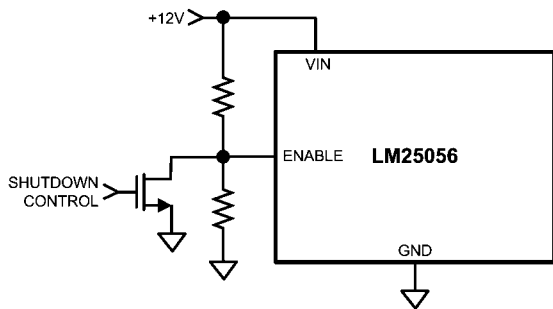

30180017

FIGURE 1. ENABLE Control

When taken low, this logic pin will reduce the quiescent current for the device and will no longer respond to PMBus commands. Also, taking the ENABLE low is a functional reset of the LM25056A. Raising ENABLE sets the part to its default operation. If this functionality is not used, then ENABLE should be left floating (an internal pull-up will maintain its operation) or tied to an external VDD voltage. Do not tie ENABLE to the onboard VDD. The VDD power-up is delayed and when power is first applied, and VDD starts low. This in turn will keep ENABLE low and the LM25056A will not start up.

VDD and VREF also have a power-on-reset (POR) circuit that holds the LM25056A in reset until it reaches the operating state. Note that if either of these output lines are inadvertently pulled low, the device is reset to its initial default state, erasing the volatile memory the same as ENABLE pulled low. Once VDD and VREF have reached the POR threshold of 2.4V, the device comes out of reset.

As an example, the SMBus address of the LM25056A is captured based on the states (GND, NC, VDD) of the ADR0, ADR1, and ADR2 pins during turn on and is latched into a volatile register once the ENABLE pin is determined to be high and the VDD and VREF has exceeded its POR threshold of 2.4V. Reassigning or postponing the address capture can be accomplished by holding the ENABLE pin to AGND. For more information on the operation of these pins, please see the PMBus Address Lines section of this datasheet.

The logic and volatile memory can also be reset with a PMBus write to the MFR_DEVICE_SETUP (D9h) register into the software reset bit. However, this software reset will not trigger a read of the states of the address pins as the ENABLE pin or VDD and VREF POR events will.

VDD Sub-Regulator

The LM25056A contains an internal linear sub-regulator which steps down the input voltage to generate a 3.7V rail used for powering low voltage and low power circuitry. When the input voltage is below 3.7V, VDD will track VIN. For input voltages 3.3V and below, VDD should be tied directly to VIN to avoid the dropout of the sub-regulator. The VDD sub-regulator should be used as the pull-up supply for the ADR2, ADR1, and ADR0 pins if they are to be tied high. It may also be used as the pull-up supply for SMBus signals (SDA, SCL, SMBA). The VDD sub-regulator is not designed to drive high currents and should not be loaded to drive high current circuits. The VDD pin is current limited to 50 mA in order to protect the LM25056A in the event of a short. The sub-regulator requires a ceramic bypass capacitance of 1 μ F or greater to be placed as close to VDD as the PCB layout allows.

Additionally, VDD can be driven from an external source to maintain telemetry readings for VIN and temperature if the VIN drops below its operation point. To do this, use an external 5V supply driving the VDD through a Schottky diode. This allows for telemetry readings down to VIN=0. A large capacitor (100 μ F) can also be placed at on the VDD line to momentarily supply current to the device to similarly maintain telemetry readings that would normally shutdown and reset the device. Note that when using an external VDD drive, ENABLE will not operate independently. To use this functionality, simply connect the external VDD source to ENABLE and lower this source to put the LM25056A into low power mode.

Remote Temperature Sensing

The LM25056A is designed to measure temperature remotely using an MMBT3904 NPN transistor. The base and collector

of the MMBT3904 should be connected to the DIODE pin and the emitter of the MMBT3904 connected to AGND. Place the MMBT3904 near the device whose temperature is to be monitored. In noisy environments with large currents or switching noise, it is especially important to bring this connection back to AGND and not just to the nearest ground plane. If the temperature of a pass MOSFET is to be measured, the MMBT3904 should be placed as close to device as the layout allows. The temperature is measured by means of a change in an external diode voltage in response to a step in current supplied by DIODE. DIODE sources 9.2 μ A but pulses 240 μ A once every millisecond in order to measure the diode temperature. Care must be taken in the PCB layout to keep the parasitic resistance between DIODE and the MMBT3904 low so as not to degrade the measurement. Additionally, a small 100 pF bypass capacitor can be placed in parallel with the MMBT3904 to reduce the effects of noise. The temperature can be read using the READ_TEMPERATURE_1 PMBus command (8Dh). The default warning limit of the LM25056A will cause SMBA to be pulled low if the measured temperature code exceeds 07D0h. The PMBus will also indicate an over temperature fault if the measured temperature code exceeds 0960h. These thresholds can be reprogrammed via the PMBus interface using the OT_WARN_LIMIT (51h) and OT_FAULT_LIMIT (4Fh) commands. If the temperature measurement and protection capability of the LM25056A is not used the DIODE pin should be grounded.

Application Section

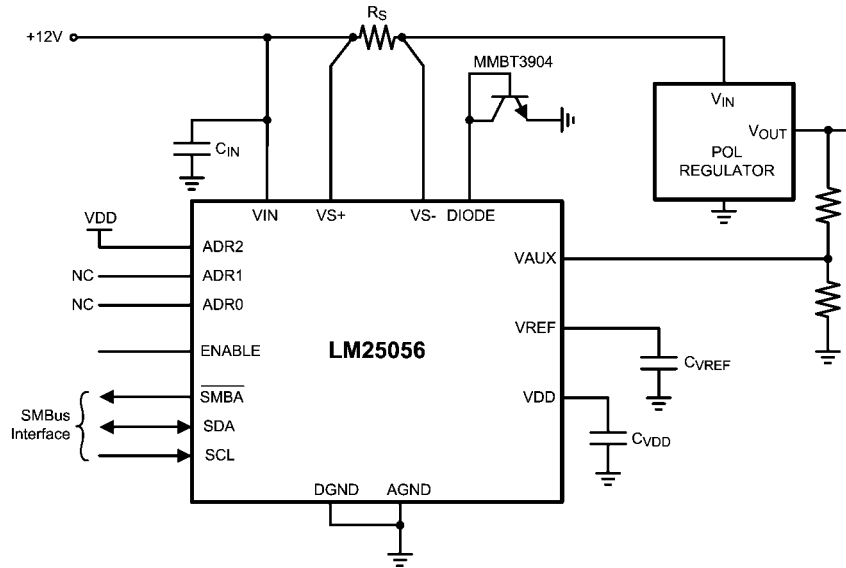

30180001

FIGURE 2. Typical Application Circuit

DESIGN-IN PROCEDURE

(Refer to [Figure 2](#) for Typical Application Circuit) Shown here is the step-by-step procedure for hardware design of the LM25056A. This procedure refers to section numbers that provide detailed information on the following design steps. The recommended design-in procedure is as follows:

Current Range, R_S : Determine the current range based on the voltage dropped across the sense resistor (R_S). Depending on the GAIN setting, the voltage across the sense resistor to get a full scale reading for the current measurement should be 30 mV for GAIN=0 and 60 mV for GAIN=1. Use the [Equation 1](#) to determine the value for R_S .

Refer to Programming Guide section: After all hardware design is complete, refer to the programming guide for a step by step procedure regarding software.

CURRENT RANGE, (R_S)

The LM25056A monitors current by measuring the voltage across the sense resistor (R_S) connected from VS+ to VS-. The required resistor value is calculated from:

$$R_S = \frac{V_S}{I_{FS}} \quad (1)$$

where I_{FS} is the expected full scale current range based on the current sense gain setting (GAIN). If the voltage across

R_S reaches V_S , the current measurement will reach the full scale measurement. As mentioned before, it is important to limit the current to the full scale reading. While there is internal circuitry intended to maintain the integrity of the other readings in the telemetry, the ADC and MUX are shared and overranging an input may compromise the integrity of the other readings.

V_S can be set to either 30 mV or 60 mV through software commands. This setting defaults to the sense voltage full scale of 30 mV (GAIN = 0), or it can be set to 60 mV (GAIN = 1). The value can be set via the PMBus with the MFR_DEVICE_SETUP (D9h) command, which defaults to the 30 mV setting. Once the current measurement full scale is known and the V_S range is chosen, calculate the shunt based on that input voltage and maximum current range. The maximum load current in normal operation can be used to determine the required power rating for resistor R_S .

Connections from R_S to the LM25056A should be made using Kelvin techniques. In the suggested layout of [Figure 3](#), the small pads at the lower corners of the sense resistor connect only to the sense resistor terminals and not to the traces carrying the high current. With this technique, only the voltage across the sense resistor is applied to VS+ and VS-, eliminating the voltage drop across the high current solder connections.

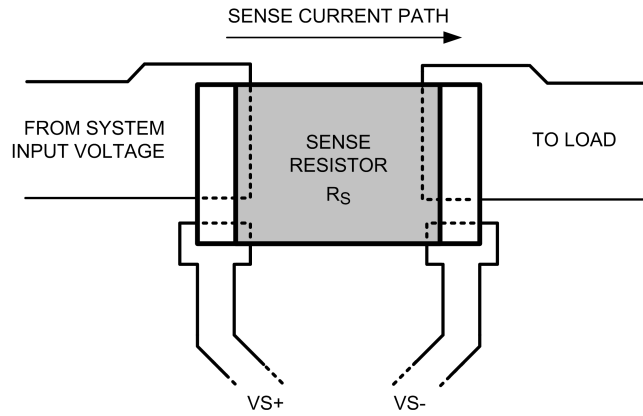

30180019

FIGURE 3. Sense Resistor Connections

PC BOARD GUIDELINES

The following guidelines should be followed when designing the PC board for the LM25056A:

- Place the LM25056A close to the board's input connector to minimize trace inductance from the connector to following devices.
- Place a small capacitor, C_{IN} , (0.1 μ F) directly adjacent to the VIN and AGND and DGND pins of the LM25056A to help minimize transients which may occur on the input supply line. Transients of several volts can easily occur when the load current is shut off.
- Place a 1 μ F capacitor as close as possible to VREF pin.
- Place a 1 μ F capacitor as close as possible to VDD pin.
- The sense resistor (R_S) should be placed close to the LM25056A. In particular, the traces to the VS+, VS-, and VIN

pins should be made as low resistance as practical to ensure maximum current and power measurement accuracy. Connect R_S using the Kelvin techniques shown in [Figure 3](#).

- The high current path from the board's input to the load and the return path should be parallel and close to each other to minimize loop inductance.
- The ground connections for the various components around the LM25056A should be connected directly to each other, and to the LM25056A's DGND and AGND pins, and then connected to the system ground at one point. Do not connect the various component grounds to each other through the high current ground line. The ground of the MMBT3904 should also be connected to the AGND pin to prevent corruption of the temperature diode measurement.

PMBus Command Support

The device features an SMBus interface that allows the use of PMBus commands to set warn levels, error masks, and get

telemetry on V_{IN} , V_{AUX} , I_{IN} , P_{IN} , and temperature. The supported PMBus commands are shown in [Table 1](#).

TABLE 1. Supported PMBus Commands

Code	Name	Function	R/W	Number Of Data Bytes	Default Value
03h	CLEAR_FAULTS	Clears the status registers and re-arms the black box registers for updating.	Send Byte	0	
19h	CAPABILITY	Retrieves the device capability.	R	1	B0h
4Fh	OT_FAULT_LIMIT	Retrieves or stores over temperature fault limit threshold.	R/W	2	0960h
51h	OT_WARN_LIMIT	Retrieves or stores over temperature warn limit threshold.	R/W	2	07D0h
57h	VIN_OV_WARN_LIMIT	Retrieves or stores input over-voltage warn limit threshold.	R/W	2	0FFFh
58h	VIN_UV_WARN_LIMIT	Retrieves or stores input under-voltage warn limit threshold.	R/W	2	0000h
78h	STATUS_BYTE	Retrieves information about the parts operating status.	R	1	01h
79h	STATUS_WORD	Retrieves information about the parts operating status.	R	2	1001h
7Ch	STATUS_INPUT	Retrieves information about input status.	R	1	00h
7Dh	STATUS_TEMPERATURE	Retrieves information about temperature status.	R	1	00h
7Eh	STATUS_CML	Retrieves information about communications status.	R	1	00h
80h	STATUS_MFR_SPECIFIC	Retrieves information about manufacturer specific device status.	R	1	10h
88h	READ_VIN	Retrieves input voltage measurement.	R	2	0000h
8Dh	READ_TEMPERATURE_1	Retrieves temperature measurement.	R	2	0000h
99h	MFR_ID	Retrieves manufacturer ID in ASCII characters (NSC).	R	3	4Eh 53h 43h
9Ah	MFR_MODEL	Retrieves Part number in ASCII characters. (LM25056A).	R	8	4Ch 4Dh 32h 35h 30h 35h 36h 00h
9Bh	MFR_REVISION	Retrieves part revision letter/number in ASCII (e.g., AA).	R	2	41h 41h
D0h	MFR_SPECIFIC_00 MFR_READ_VAUX	Retrieves auxiliary voltage measurement.	R	2	0000h
D1h	MFR_SPECIFIC_01 MFR_READ_IIN	Retrieves input current measurement.	R	2	0000h
D2h	MFR_SPECIFIC_02 MFR_READ_PIN	Retrieves input power measurement.	R	2	0000h
D3h	MFR_SPEICIFIC_03 MFR_IIN_OC_WARN_LIMIT	Retrieves or stores input current limit warn threshold.	R/W	2	0FFFh
D4h	MFR_SPECIFIC_04 MFR_PIN_OP_WARN_LIMIT	Retrieves or stores input power limit warn threshold.	R/W	2	0FFFh
D5h	MFR_SPECIFIC_05 MFR_READ_PIN_PEAK	Retrieves maximum input power measurement.	R	2	0000h
D6h	MFR_SPECIFIC_06 MFR_CLEAR_PIN_PEAK	Resets the contents of the peak input power register to zero.	Send Byte	0	

Code	Name	Function	R/W	Number Of Data Bytes	Default Value
D8h	MFR_SPECIFIC_08 MFR_ALERT_MASK	Retrieves or stores user SMBA fault mask.	R/W	2	0000h
D9h	MFR_SPECIFIC_09 MFR_DEVICE_SETUP	Retrieves or stores information about the LM25056A setup.	R/W	1	0000h
DAh	MFR_SPECIFIC_10 MFR_BLOCK_READ	Retrieves most recent diagnostic and telemetry information in a single transaction.	R	12	0080h 0000h 0000h 0000h 0000h
DBh	MFR_SPECIFIC_11 MFR_SAMPLES_FOR_AVG	Exponent value AVGN for number of samples to be averaged, range = 00h to 0Ch .	R/W	1	00h
DCh	MFR_SPECIFIC_12 MFR_READ_AVG_VIN	Retrieves averaged input voltage measurement.	R	2	0000h
DDh	MFR_SPECIFIC_13 MFR_READ_AVG_VAUX	Retrieves averaged auxiliary voltage measurement.	R	2	0000h
DEh	MFR_SPECIFIC_14 MFR_READ_AVG_IIN	Retrieves averaged input current measurement.	R	2	0000h
DFh	MFR_SPECIFIC_15 MFR_READ_AVG_PIN	Retrieves averaged input power measurement.	R	2	0000h
E0h	MFR_SPECIFIC_16 MFR_BLACK_BOX_READ	Captures diagnostic and telemetry information which are latched when an SMBA occurs after faults have been cleared.	R	12	0080h 0000h 0000h 0000h 0000h
E1h	MFR_SPECIFIC_17 MFR_DIAGNOSTIC_WORD_READ	Manufacturer-specific parallel of the STATUS_WORD to convey all FAULT/WARN data in a single transaction.	R	2	0080h
E2h	MFR_SPECIFIC_18 MFR_AVG_BLOCK_READ	Retrieves most recent average telemetry and diagnostic information in a single transaction.	R	12	0080h 0000h 0000h 0000h 0000h
E3h	MFR_SPECIFIC_19 MFR_VAUX_OV_WARN_LIMIT	Retrieves or stores auxiliary over-voltage warn limit threshold.	R	2	0FFFh
E4h	MFR_SPECIFIC_20 MFR_VAUX_UV_WARN_LIMIT	Retrieves or stores auxiliary under-voltage warn limit threshold.	R	2	0000h

STANDARD PMBus Commands

CLEAR_FAULTS (03h)

The CLEAR_FAULTS command is a standard PMBus command that resets all stored warning and fault flags and the $\overline{\text{SMBA}}$ signal. If a fault or warning condition still exists when the CLEAR_FAULTS command is issued, the $\overline{\text{SMBA}}$ signal may not clear or will re-assert almost immediately. This command uses the PMBus send byte protocol.

CAPABILITY (19h)

The CAPABILITY command is a standard PMBus command that returns information about the PMBus functions supported by the LM25056A. This command is read with the PMBus read byte protocol.

TABLE 2. CAPABILITY Register

Value	Meaning	Default
B0h	Supports Packet Error Check, 400Kbits/sec, Supports SMBus Alert	B0h

OT_FAULT_LIMIT (4Fh)

The OT_FAULT_LIMIT is a standard PMBus command that allows configuring or reading the threshold for the overtemperature fault detection. Reading and writing to this register should use the coefficients shown in the Telemetry and Warning Conversion Coefficients Table. Accesses to this command should use the PMBus read or write word protocol. If the measured temperature exceeds this value, an Overtemperature fault is triggered, OT Fault flags are set and the $\overline{\text{SMBA}}$ signal is asserted.

TABLE 3. OT_FAULT_LIMIT Register

Value	Meaning	Default
0h – 0FFEh	Overtemperature Fault Threshold Value	0960h
0FFFh	Overtemperature Fault detection disabled	n/a

OT_WARN_LIMIT (51h)

The OT_WARN_LIMIT is a standard PMBus command that allows configuring or reading the threshold for the overtemperature warning detection. Reading and writing to this register should use the coefficients shown in the Telemetry and Warning Conversion Coefficients Table. Accesses to this command should use the PMBus read or write word protocol.

If the measured temperature exceeds this value, an Overtemperature warning is triggered and the OT Warning flags are set and the $\overline{\text{SMBA}}$ signal is asserted.

TABLE 4. OT_WARN_LIMIT Register

Value	Meaning	Default
0h – 0FFEh	Overtemperature Warn Threshold Value	07D0h
0FFFh	Overtemperature Warn detection disabled	n/a

VIN_OV_WARN_LIMIT (57h)

The VIN_OV_WARN_LIMIT is a standard PMBus command that allows configuring or reading the threshold for the VIN overvoltage warning detection. Reading and writing to this register should use the coefficients shown in the Telemetry and Warning Conversion Coefficients Table. Accesses to this command should use the PMBus read or write word protocol. If the measured value of VIN rises above the value in this register, VIN OV Warn flags are set and the $\overline{\text{SMBA}}$ signal is asserted.

TABLE 5. VIN_OV_WARN_LIMIT Register

Value	Meaning	Default
0h – 0FFEh	VIN Overvoltage Warning detection threshold	0FFFh (disabled)
0FFFh	VIN Overvoltage Warning disabled	n/a

VIN_UV_WARN_LIMIT (58h)

The VIN_UV_WARN_LIMIT is a standard PMBus command that allows configuring or reading the threshold for the VIN undervoltage warning detection. Reading and writing to this register should use the coefficients shown in the Telemetry and Warning Conversion Coefficients Table. Accesses to this command should use the PMBus read or write word protocol. If the measured value of VIN falls below the value in this register, VIN UV Warn flags are set and the $\overline{\text{SMBA}}$ signal is asserted.

TABLE 6. VIN_UV_WARN_LIMIT Register

Value	Meaning	Default
1h – 0FFFh	VIN Undervoltage Warning detection threshold	0000h (disabled)
0000h	VIN Undervoltage Warning disabled	n/a

STATUS_BYTE (78h)

The STATUS_BYTE is a standard PMBus command that returns the value of a number of flags indicating the state of the LM25056A. Accesses to this command should use the PM-

Bus read byte protocol. To clear bits in this register, the underlying fault should be cleared and a CLEAR_FAULTS command issued.

TABLE 7. STATUS_BYTE Definitions

Bit	Name	Meaning	Default
7	BUSY	Not supported	0
6	OFF	Not supported	0
5	VOUT_OV	Not supported	0
4	IOUT_OC	Not supported	0
3	VIN_UV	An input undervoltage fault has occurred	0
2	TEMPERATURE	A temperature fault or warning has occurred	0
1	CML	A Communication Fault has occurred	0
0	NONE OF THE ABOVE	A fault or warning not listed in bits [7:1] has occurred	1

STATUS_WORD (79h)

The STATUS_WORD is a standard PMBus command that returns the value of a number of flags indicating the state of the LM25056A. Accesses to this command should use the

PMBus read word protocol. To clear bits in this register, the underlying fault should be cleared and a CLEAR_FAULTS command issued. The INPUT and VIN UV flags will default to 1 on startup.

TABLE 8. STATUS_WORD Definitions

Bit	Name	Meaning	Default
15	VOUT	Not supported	0
14	IOUT/POUT	Not supported	0
13	INPUT	An input voltage or current fault has occurred	0
12	MFR	A manufacturer specific fault or warning has occurred	1
11	POWER_GOOD#	Not supported	0
10	FANS	Not supported	0
9	OTHER	Not supported	0
8	UNKNOWN	Not supported	0
7	BUSY	Not supported	0
6	OFF	Not supported	0
5	VOUT_OV	Not supported	0
4	IOUT_OC	Not supported	0
3	VIN_UV	An input undervoltage fault has occurred	0
2	TEMPERATURE	A temperature fault or warning has occurred	0
1	CML	A communication fault has occurred	0
0	NONE OF THE ABOVE	A fault or warning not listed in bits [7:1] has occurred	1

STATUS_INPUT (7Ch)

The STATUS_INPUT is a standard PMBus command that returns the value of the of a number of flags related to input voltage, current, and power. Accesses to this command

should use the PMBus read byte protocol. To clear bits in this register, the underlying fault should be cleared and a CLEAR_FAULTS command issued.

TABLE 9. STATUS_INPUT Definitions

Bit	Name	Meaning	Default
7	VIN OV Fault	Not supported	0
6	VIN OV Warn	An input overvoltage warning has occurred	0
5	VIN UV Warn	An input undervoltage warning has occurred	0
4	VIN UV Fault	Not supported	0
3	Insufficient Voltage	Not supported	0
2	IIN OC Fault	Not supported	0
1	IIN OC Warn	An input overcurrent warning has occurred	0
0	PIN OP Warn	An input overpower warning has occurred	0

STATUS_TEMPERATURE (7Dh)

The STATUS_TEMPERATURE is a standard PMBus command that returns the value of the of a number of flags related to the temperature telemetry value. Accesses to this com-

mand should use the PMBus read byte protocol. To clear bits in this register, the underlying fault should be cleared and a CLEAR_FAULTS command issued.

TABLE 10. STATUS_TEMPERATURE Definitions

Bit	Name	Meaning	Default
7	OT FAULT	An overtemperature fault has occurred	0
6	OT WARN	An overtemperature warning has occurred	0
5	UT WARN	Not supported	0
4	UT FAULT	Not supported	0
3	reserved	Not supported	0
2	reserved	Not supported	0
1	reserved	Not supported	0
0	reserved	Not supported	0

STATUS_CML (7Eh)

The STATUS_CML is a standard PMBus command that returns the value of a number of flags related to communication

faults. Accesses to this command should use the PMBus read byte protocol. To clear bits in this register, a CLEAR_FAULTS command should be issued.

TABLE 11. STATUS_CML Definitions

Bit	Meaning	Default
7	Invalid or unsupported command received	0
6	Invalid or unsupported data received	0
5	Packet Error Check failed	0
4	Not supported	0
3	Not supported	0
2	Reserved	0
1	Miscellaneous communications fault has occurred	0
0	Not supported	0

STATUS_MFR_SPECIFIC (80h)

The STATUS_MFR_SPECIFIC command, is a standard PMBus command that contains manufacturer specific status information. Accesses to this command should use the PMBus read byte protocol. To clear bits in this register, the underlying fault should be cleared and a CLEAR_FAULTS command should be issued.

TABLE 12. STATUS_MFR_SPECIFIC Definitions

Bit	Meaning	Default
7	Not supported	0
6	Not supported	0
5	Not supported	0
4	Defaults loaded	1
3	Not supported	0
2	Not supported	0
1	A VAUX Overvoltage Warning has occurred	0
0	A VAUX Undervoltage Warning has occurred	0

READ_VIN (88h)

The READ_VIN is a standard PMBus command that returns the 12 bit measured value of the input voltage as read from the VIN pin. Reading this register should use the coefficients shown in the Telemetry and Warning Conversion Coefficients Table. Accesses to this command should use the PMBus read word protocol. This value is also used internally for the VIN Over and Under Voltage Warning detection.

TABLE 13. READ_VIN Register

Value	Meaning	Default
0h – 0FFFh	Measured value for VIN	0000h

READ_TEMPERATURE_1 (8Dh)

The READ_TEMPERATURE_1 is a standard PMBus command that returns the signed value of the temperature measured by the external temperature sense diode. Reading this register should use the coefficients shown in the Telemetry and Warning Conversion Coefficients Table. Accesses to this command should use the PMBus read word protocol. This value is also used internally for the Over Temperature Fault and Warning detection. This data has a range of -256°C to +255°C after the coefficients are applied.

TABLE 14. READ_TEMPERATURE_1 Register

Value	Meaning	Default
0h – 0FFFh	Measured value for TEMPERATURE	0000h

MFR_ID (99h)

The MFR_ID is a standard PMBus command that returns the identification of the manufacturer. To read the manufacturer ID, use the PMBus block read protocol.

TABLE 15. MFR_ID Register

Byte	Name	Value
0	Number of bytes	03h
1	MFR ID-1	4Eh 'N'
2	MFR ID-2	53h 'S'
3	MFR ID-3	43h 'C'

MFR_MODEL (9Ah)

The MFR_MODEL is a standard PMBus command that returns the part number of the chip. To read the manufacturer model, use the PMBus block read protocol.

TABLE 16. MFR_MODEL Register

Byte	Name	Value
0	Number of bytes	08h
1	MFR ID-1	4Ch 'L'
2	MFR ID-2	4Dh 'M'
3	MFR ID-3	32h '2'
4	MFR ID-4	35h '5'
5	MFR ID-5	30h '0'
6	MFR ID-6	35h '5'
7	MFR ID-7	36h '6'
8	MFR ID-8	00h

MFR_REVISION (9Bh)

The MFR_REVISION is a standard PMBus command that returns the revision level of the part. To read the manufacturer revision, use the PMBus block read protocol.

TABLE 17. MFR_REVISION Register

Byte	Name	Value
0	Number of bytes	02h
1	MFR ID-1	41h 'A'
2	MFR ID-2	41h 'A'

Manufacturer Specific PMBus Commands

MFR_SPECIFIC_00: MFR_READ_VAUX (D0h)

The MFR_READ_VAUX command will report the 12-bit ADC measured auxiliary voltage. Voltages greater than or equal to 1.199V to AGND will be reported at plus full scale (0FFFh). Voltages less than or equal to 0V referenced to AGND will be reported as 0 (0000h). Coefficients for the VAUX value are dependent on the value of the external divider (if used). To read data from the MFR_READ_VAUX command, use the PMBus Read Word protocol.

TABLE 18. MFR_READ_VAUX Register

Value	Meaning	Default
0h – 0FFFh	Measured value for AUX input	0000h

MFR_SPECIFIC_01: MFR_READ_IIN (D1h)

The MFR_READ_IIN command will report the 12-bit ADC measured current sense voltage. To read data from the MFR_READ_IIN command, use the PMBus™ Read Word protocol. Reading this register should use the coefficients shown in the Telemetry and Warning Conversion Coefficients Table. Please see the section on coefficient calculations to calculate the values to use.

TABLE 19. MFR_READ_IIN Register

Value	Meaning	Default
0h – 0FFFh	Measured value for input current sense voltage	0000h

MFR_SPECIFIC_02: MFR_READ_PIN (D2h)

The MFR_READ_PIN command will report the upper 12-bits of the VIN x IIN product as measured by the 12-bit ADC. To read data from the MFR_READ_PIN command, use the PMBus Read Word protocol. Reading this register should use the coefficients shown in the Telemetry and Warning Conversion Coefficients Table.

TABLE 20. MFR_READ_PIN Register

Value	Meaning	Default
0h – 0FFFh	Value for input current x input voltage	0000h

MFR_SPECIFIC_03: MFR_IIN_OC_WARN_LIMIT (D3h)

The MFR_IIN_OC_WARN_LIMIT PMBus command sets the input overcurrent warning threshold. In the event that the input current rises above the value set in this register, the IIN Overcurrent flags are set in the status registers and the SMBA is asserted. To access the MFR_IIN_OC_WARN_LIMIT register, use the PMBus Read/Write Word protocol. Reading/writing to this register should use the coefficients shown in the Telemetry and Warning Conversion Coefficients Table.

TABLE 21. MFR_IIN_OC_WARN_LIMIT Register

Value	Meaning	Default
0h – 0FFEh	Value for input over current warn limit	0FFFh
0FFFh	Input over current warning disabled	n/a

MFR_SPECIFIC_04: MFR_PIN_OP_WARN_LIMIT (D4h)

The MFR_PIN_OP_WARN_LIMIT PMBus command sets the input overpower warning threshold. In the event that the input power rises above the value set in this register, the PIN Overpower flags are set in the status registers and the SMBA is asserted. To access the MFR_PIN_OP_WARN_LIMIT register, use the PMBus Read/Write Word protocol. Reading/writing to this register should use the coefficients shown in the Telemetry and Warning Conversion Coefficients Table.

TABLE 22. MFR_PIN_OP_WARN_LIMIT Register

Value	Meaning	Default
0h – 0FFEh	Value for input over power warn limit	0FFFh
0FFFh	Input over power warning disabled	n/a

MFR_SPECIFIC_05: MFR_READ_PIN_PEAK (D5h)

The MFR_READ_PIN_PEAK command will report the maximum input power measured since a Power On reset or the last MFR_CLEAR_PIN_PEAK command. To access the MFR_READ_PIN_PEAK command, use the PMBus Read Word protocol. Use the coefficients shown in the Telemetry and Warning Coefficients Table.

TABLE 23. MFR_READ_PIN_PEAK Register

Value	Meaning	Default
0h – 0FFEh	Maximum Value for input current x input voltage since reset or last clear	0000h

MFR_SPECIFIC_06: MFR_CLEAR_PIN_PEAK (D6h)

The MFR_CLEAR_PIN_PEAK command will clear the MFR_READ_PIN_PEAK register. This command uses the PMBus Send Byte protocol.

MFR_SPECIFIC_08: MFR_ALERT_MASK (D8h)

The MFR_ALERT_MASK is used to mask the SMBA when a specific fault or warning has occurred. Each bit corresponds to one of the 9 different analog and digital faults or warnings that would normally result in an SMBA being asserted. When the corresponding bit is high, that condition will not cause the SMBA to be asserted. If that condition occurs, the registers where that condition is captured will still be updated (STATUS registers, MFR_DIAGNOSTIC_WORD, OT_FAULT_LIMIT). This register is accessed with the PMBus Read / Write Word protocol.

TABLE 24. MFR_ALERT_MASK Definitions

BIT	NAME	DEFAULT
15	VAUX UNDERVOLTAGE WARN	0
14	IIN LIMIT WARN	0
13	VIN UNDERVOLTAGE WARN	0
12	VIN OVERVOLTAGE WARN	0
11	Reserved, always set to 0	0
10	OVERTEMPERATURE WARN	0
9	VAUX OVERVOLTAGE WARN	0
8	OVERPOWER LIMIT WARN	0
7	Reserved, always set to 0	0
6	Reserved, always set to 0	0
5	Reserved, always set to 0	0
4	Reserved, always set to 0	0
3	Reserved, always set to 0	0
2	OVERTEMPERATURE FAULT	0
1	CML FAULT (Communications Fault)	0
0	Reserved, always set to 0	0

MFR_SPECIFIC_09: MFR_DEVICE_SETUP (D9h)

The MFR_DEVICE_SETUP command may be used to define operation or reset the LM25056A under host control. This command is accessed with the PMBus read / write byte protocol.

TABLE 25. MFR_DEVICE_SETUP Byte Format

Bit	Name	Meaning
7	Reserved, always set to 0	
6	Reserved, always set to 0	
5	Reserved, always set to 0	
4	Current sense gain	GAIN = 0, Low setting (30mV)
		GAIN = 1, High setting (60mV)
3	Reserved, always set to 0	
2	Reserved, always set to 0	
1	Reserved, always set to 0	
0	Software reset	0 = Default
		1 = Reset

Within this command byte, the current sense gain bit changes the range and coefficients used for current and power measurements as well as relevant warning registers. The software reset bit is used to reset the LM25056A. Writing a 1 to this bit will reset the device back to its default startup values.

MFR_SPECIFIC_10: MFR_BLOCK_READ (DAh)

The MFR_BLOCK_READ command concatenates the MFR_DIAGNOSTIC_WORD_READ with input telemetry information (IIN, VAUX, VIN, PIN) as well as READ_TEMPERATURE_1 to capture all of the operating information of the

LM25056A in a single SMBus transaction. The block is 12 bytes long with telemetry information being sent out in the same manner as if an individual READ_XXX command had been issued (shown below). The contents of the block read register are updated every clock cycle (85 ns) as long as the SMBus interface is idle. MFR_BLOCK_READ also guarantees that the VIN, VAUX, IIN and PIN measurements are all time-aligned whereas there is a chance they may not be if retrieved with individual PMBus commands.

The Block Read command is read via the PMBus block read protocol.

TABLE 26. MFR_BLOCK_READ Register Format

Byte Count (always 12)	(1 byte)
DIAGNOSTIC WORD	(1 Word)
IIN_BLOCK	(1 Word)
VAUX_BLOCK	(1 Word)
VIN_BLOCK	(1 Word)
PIN_BLOCK	(1 Word)
TEMP_BLOCK	(1 Word)

MFR_SPECIFIC_11: MFR_SAMPLES_FOR_AVG (DBh)

The MFR_SAMPLES_FOR_AVG is a manufacturer specific command for setting the number of samples used in computing the average values for IIN, VIN, VAUX, PIN. The decimal equivalent of the AVGN nibble is the power of 2 samples (e.g. AVGN=12 equates to 4096 samples used in computing the average). The LM25056A supports average numbers of 1, 2, 4, 8, 16, 32, 64, 128, 256, 512, 1024, 2048, 4096. The MFR_SAMPLES_FOR_AVG number applies to average values of IIN, VIN, VAUX, PIN simultaneously. The LM25056A uses simple averaging. This is accomplished by summing consecutive results up to the number programmed, then dividing by the number of samples. Averaging is calculated according to the following sequence:

$$Y = (X_{(N)} + X_{(N-1)} + \dots + X_{(0)}) / N$$

When the averaging has reached the end of a sequence (for example, 4096 samples are averaged), then a whole new sequence begins that will require the same number of samples

(in this example, 4096) to be taken before the new average is ready.

TABLE 27. MFR_SAMPLES_FOR_AVERAGE

AVGN	N = 2 ^{AVGN}	Averaging/Register Update Period (ms)
0000	1	1
0001	2	2
0010	4	4
0011	8	8
0100	16	16
0101	32	32
0110	64	64
0111	128	128
1000	256	256
1001	512	512
1010	1024	1024
1011	2048	2048
1100	4096	4096

Note that a change in the MFR_SAMPLES_FOR_AVG register will not be reflected in the average telemetry measurements until the present averaging interval has completed. The default setting for AVGN is 0000 and therefore the average telemetry will mirror the instantaneous telemetry until a value higher than zero is programmed.

The MFR_SAMPLES_FOR_AVG register is accessed via the PMBus read / write byte protocol.

TABLE 28. MFR_SAMPLES_FOR_AVG Register

Value	Meaning	Default
0h – 0Ch	Exponent for number of samples to average over	00h

MFR_SPECIFIC 12: MFR_READ_AVG_VIN (DCh)

The MFR_READ_AVG_VIN command will report the 12-bit ADC measured input average voltage. If the data is not ready, the returned value will be the previous averaged data. However, if there is no previously averaged data the default value (0000h) will be returned. This data is read with the PMBus Read Word protocol. This register should use the coefficients shown in the Telemetry and Warning Conversion Coefficients Table.

TABLE 29. MFR_READ_AVG_VIN Register

Value	Meaning	Default
0h – 0FFFh	Average of measured values for input voltage	0000h

MFR_SPECIFIC 13: MFR_READ_AVG_VAUX (DDh)

The MFR_READ_AVG_AUX command will report the 12-bit ADC measured auxiliary average voltage. If the data is not ready, the returned value will be the previous averaged data. However, if there is no previously averaged data the default value (0000h) will be returned. This data is read with the PMBus Read Word protocol. This register should use the coefficients

shown in the Telemetry and Warning Conversion Coefficients Table.

TABLE 30. MFR_READ_AVG_VAUX Register

Value	Meaning	Default
0h – 0FFFh	Average of measured values for auxiliary voltage	0000h

MFR_SPECIFIC 14: MFR_READ_AVG_IIN (DEh)

The MFR_READ_AVG_IIN command will report the 12-bit ADC measured current sense average voltage. If the data is not ready, the returned value will be the previous averaged data. However, if there is no previously averaged data the default value (0000h) will be returned. This data is read with the PMBus Read Word protocol. This register should use the coefficients shown in the Telemetry and Warning Conversion Coefficients Table.

TABLE 31. MFR_READ_AVG_IIN Register

Value	Meaning	Default
0h – 0FFFh	Average of measured values for current sense voltage	0000h

MFR_SPECIFIC 15: MFR_READ_AVG_PIN (DFh)

The MFR_READ_AVG_PIN command will report the upper 12-bits of the average VIN x IIN product as measured by the 12-bit ADC. If the data is not ready, the returned value will be the previous averaged data. However, if there is no previously averaged data the default value (0000h) will be returned. This data is read with the PMBus Read Word protocol. This register should use the coefficients shown in the Telemetry and Warning Conversion Coefficients Table.

TABLE 32. MFR_READ_AVG_PIN Register

Value	Meaning	Default
0h – 0FFFh	Average of measured value for input voltage x input current sense voltage	0000h

MFR_SPECIFIC 16: MFR_BLACK_BOX_READ (E0h)

The MFR_BLACK_BOX_READ command retrieves the MFR_BLOCK_READ data which was latched in at the first assertion of SMBA. It is re-armed with the CLEAR_FAULTS command. It is the same format as the MFR_BLOCK_READ registers, the only difference being that its contents are updated with the SMBA edge rather than the internal clock edge. This command is read with the PMBus Block Read protocol.

MFR_SPECIFIC 17: MFR_DIAGNOSTIC_WORD_READ (E1h)

The MFR_DIAGNOSTIC_WORD_READ PMBus command will report all of the LM25056A faults and warnings in a single read operation. The standard response to the assertion of the SMBA signal of issuing multiple read requests to various status registers can be replaced by a single word read to the MFR_DIAGNOSTIC_WORD_READ register. The MFR_DIAGNOSTIC_WORD_READ command should be read with the PMBus Read Word protocol. The MFR_DIAGNOSTIC_WORD_READ register is also returned in the MFR_BLOCK_READ, MFR_BLACK_BOX_READ, and MFR_AVG_BLOCK_READ operations.

TABLE 33. MFR_DIAGNOSTIC_WORD_READ Format

Bit	Name	Meaning	Default
15	Reserved		0
14	MFR_IIN_OC_WARN or MFR_PIN_OP_WARN	Input Overcurrent or Overpower Warning	0
13	VIN_UV_WARN	Input Undervoltage Warning	0
12	VIN_OV_WARN	Input Overvoltage Warning	0
11	Reserved		0
10	OT_WARN	Overtemperature Warning	0
9	MFR_VAUX_UNDERVOLTAGE_WARN	VAUX Undervoltage Warning	0
8	MFR_VAUX_OVERVOLTAGE_WARN	VAUX Overvoltage Warning	0
7	CONFIG_PRESET		1
6	Reserved		0
5	Reserved		0
4	Reserved		0
3	Reserved		0
2	OT_FAULT	Over Temperature Fault	0
1	CML_FAULT	Communications Fault	0
0	Reserved		0

MFR_SPECIFIC_18: MFR_AVG_BLOCK_READ (E2h)

The MFR_AVG_BLOCK_READ command concatenates the DIAGNOSTIC_WORD with input average telemetry information (IIN, VAUX, VIN, PIN) as well as TEMPERATURE to capture all of the operating information of the part in a single PMBus transaction. The block is 12 bytes long with telemetry information being sent out in the same manner as if an individual READ_AVG_XXX command had been issued (shown below). AVG_BLOCK_READ also guarantees that the VIN, VAUX, IIN, and PIN measurements are all time-aligned whereas there is a chance they may not be if read with individual PMBus commands. To read data from the AVG_BLOCK_READ command, use the SMBus Block Read protocol.

TABLE 34. MFR_AVG_BLOCK_READ Register Format

Byte Count (always 12)	(1 byte)
DIAGNOSTIC WORD	(1 word)
AVG_IIN	(1 word)
AVG_VAUX	(1 word)
AVG_VIN	(1 word)
AVG_PIN	(1 word)
TEMPERATURE	(1 word)

MFR_SPECIFIC_19: VAUX_OV_WARN_LIMIT (E3h)

The VAUX_OV_WARN_LIMIT command allows configuring or reading the threshold for the VAUX overvoltage warning detection. Reading and writing to this register should use the

coefficients shown in the Telemetry and Warning Conversion Coefficients Table. Accesses to this command should use the PMBus read or write word protocol. If the measured value of VAUX rises above the value in this register, VAUX OV Warn flags are set and the SMBA signal is asserted.

TABLE 35. VAUX_OV_WARN_LIMIT Register

Value	Meaning	Default
0h – 0FFEh	VAUX Overvoltage Warning detection threshold	0FFFh (disabled)
0FFFh	VAUX Overvoltage Warning disabled	n/a

MFR_SPECIFIC_20: VAUX_UV_WARN_LIMIT (E4h)

The VAUX_UV_WARN_LIMIT command allows configuring or reading the threshold for the VAUX undervoltage warning detection. Reading and writing to this register should use the coefficients shown in the Telemetry and Warning Conversion Coefficients Table. Accesses to this command should use the PMBus read or write word protocol. If the measured value of VAUX falls below the value in this register, VAUX UV Warn flags are set and the SMBA signal is asserted.

TABLE 36. VAUX_UV_WARN_LIMIT Register

Value	Meaning	Default
1h – 0FFFh	VAUX Undervoltage Warning detection threshold	0000h (disabled)
0000h	VAUX Undervoltage Warning disabled	n/a

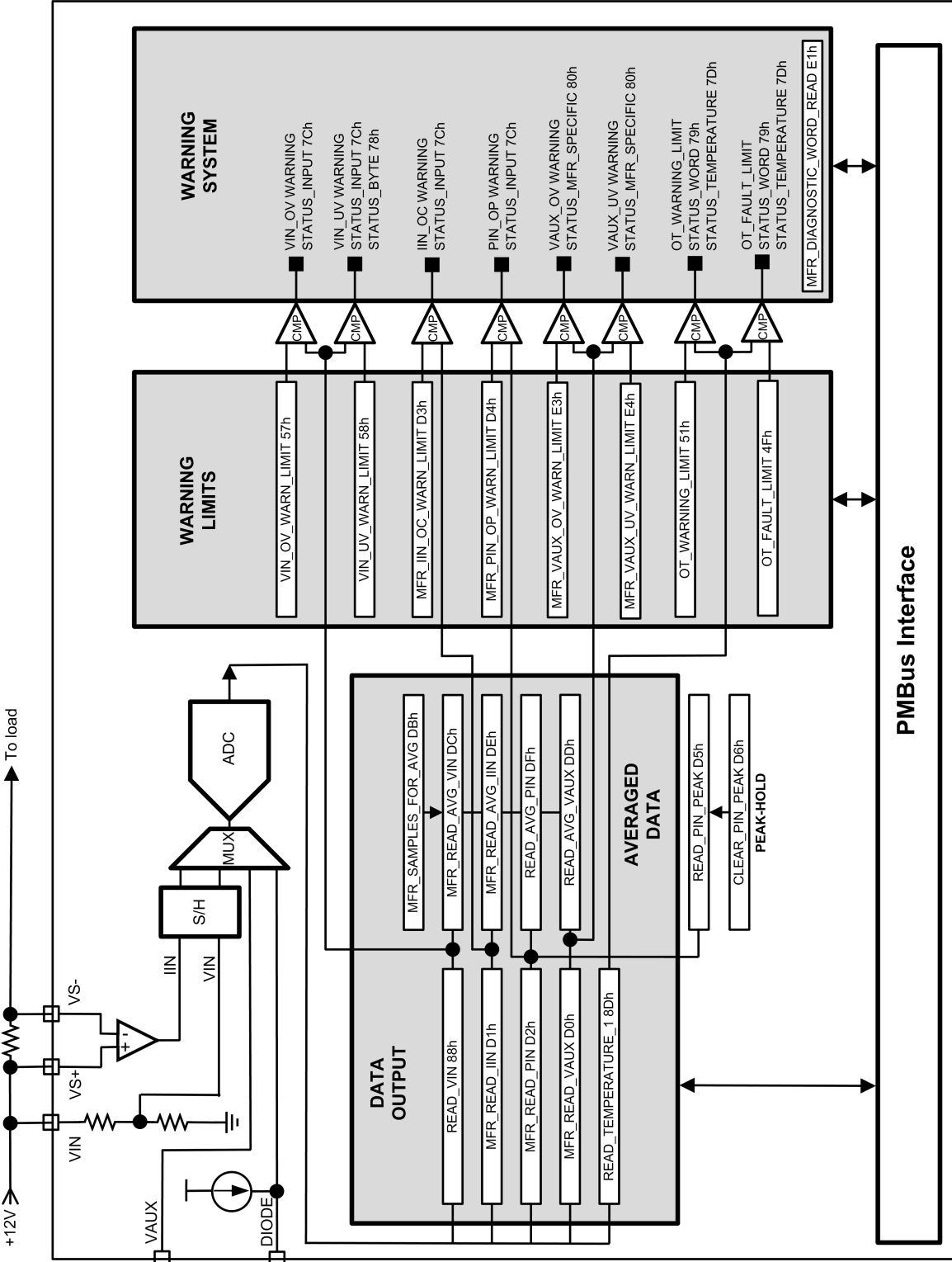

30180062

FIGURE 4. Command/Register and Alert Flow Diagram

Reading and Writing Telemetry Data and Warning Thresholds

All measured telemetry data and user programmed warning thresholds are communicated in 12 bit two's complement binary numbers read/written in 2 byte increments conforming to the Direct format as described in section 8.3.3 of the PMBus Power System Management Protocol Specification 1.1 (Part

II). The organization of the bits in the telemetry or warning word is shown in [Table 37](#), where Bit_11 is the most significant bit (MSB) and Bit_0 is the least significant bit (LSB). The decimal equivalent of all warning and telemetry words are constrained to be within the range of 0 to 4095, with the exception of temperature. The decimal equivalent value of the temperature word ranges from 0 to 65535.

TABLE 37. Telemetry and Warning Word Format

Byte	B7	B6	B5	B4	B3	B2	B1	B0
1	Bit_7	Bit_6	Bit_5	Bit_4	Bit_3	Bit_2	Bit_1	Bit_0
2	0	0	0	0	Bit_11	Bit_10	Bit_9	Bit_8

Conversion from direct format to real world dimensions of current, voltage, power, and temperature is accomplished by determining appropriate coefficients as described in section 7.2.1 of the PMBus Power System Management Protocol Specification 1.1 (Part II). According to this specification, the host system converts the values received into a reading of volts, amperes, watts, or other units using the following relationship:

$$X = \frac{1}{m}(Y \times 10^{-R} - b)$$

Where:

- X:** the calculated "real world" value (volts, amps, watt, etc.)
 - m:** the slope coefficient
 - Y:** a two byte two's complement integer received from device
 - b:** the offset, a two byte, two's complement integer
 - R:** the exponent, a one byte two's complement integer
- R is only necessary in systems where m is required to be an integer (for example, where m may be stored in a register in an integrated circuit). In those cases, R only needs to be large enough to yield the desired accuracy.

TABLE 38. Telemetry and Warning Conversion Coefficients

Commands	Condition	Format	Number of Data Bytes	m	b	R	Units
READ_VIN, MFR_READ_AVG_VIN, VIN_OV_WARN_LIMIT VIN_UV_WARN_LIMIT		DIRECT	2	16296	1343	-2	V
MFR_READ_VAUX, MFR_READ_AVG_VAUX, MFR_VAUX_OV_WARN_LIMIT MFR_VAUX_UV_WARN_LIMIT		DIRECT	2	3416	-4	0	V
*MFR_READ_IIN, MFR_IIN_OC_WARN_LIMIT, MFR_READ_AVG_IIN ,	GAIN = 0	DIRECT	2	13797	-1833	-2	A
*MFR_READ_IIN, MFR_IIN_OC_WARN_LIMIT, MFR_READ_AVG_IIN ,	GAIN = 1	DIRECT	2	6726	-537	-2	A
*MFR_READ_PIN, MFR_PIN_OP_WARN_LIMIT, MFR_READ_PIN_PEAK, MFR_READ_AVG_PIN	GAIN = 0	DIRECT	2	5501	-2908	-3	W
*MFR_READ_PIN, MFR_PIN_OP_WARN_LIMIT, MFR_READ_PIN_PEAK, MFR_READ_AVG_PIN	GAIN = 1	DIRECT	2	26882	-5646	-4	W
READ_TEMPERATURE_1, OT_FAULT_LIMIT, OT_WARN_LIMIT		DIRECT	2	1580	-14500	-2	°C

* The coefficients relating to current/power measurements and warning thresholds shown in [Table 38](#) are normalized to a sense resistor (R_S) value of 1mΩ. In general, the current/power coefficients can be calculated using the relationships shown in [Table 39](#).

TABLE 39. Current and Power Telemetry and Warning Conversion Coefficients (R_S in $m\Omega$)

Commands	Condition	Format	Number of Data Bytes	m	b	R	Units
*MFR_READ_IIN, MFR_IIN_OC_WARN_LIMIT, MFR_READ_AVG_IIN ,	GAIN = 0	DIRECT	2	$13797 \times R_S$	-1833	-2	A
*MFR_READ_IIN, MFR_IIN_OC_WARN_LIMIT, MFR_READ_AVG_IIN ,	GAIN = 1	DIRECT	2	$6726 \times R_S$	-537	-2	A
*MFR_READ_PIN, MFR_PIN_OP_WARN_LIMIT, MFR_READ_PIN_PEAK, MFR_READ_AVG_PIN	GAIN = 0	DIRECT	2	$5501 \times R_S$	-2908	-3	W
*MFR_READ_PIN, MFR_PIN_OP_WARN_LIMIT, MFR_READ_PIN_PEAK, MFR_READ_AVG_PIN	GAIN = 1	DIRECT	2	$26882 \times R_S$	-5646	-4	W

Care must be taken to adjust the exponent coefficient, R, such that the values of m and b remain within the range of -32768 to +32767. For example, if a $5\text{ m}\Omega$ sense resistor is used, the correct coefficients for the MFR_READ_IIN command with GAIN = 0 would be $m = 3363$, $b = -537$, $R = -1$.

A Note on the "b" Coefficient

Since b coefficients represent offset, for simplification b is set to zero in the following discussions.

efficients enable the data output to be converted to amps. The values shown in the example are based on having the device programmed for a 30 mV current sense range (GAIN = 0). In the 30 mV range, the LSB value is $7.25\ \mu\text{V}$ and the full scale range is 29.68 mV. In the 60 mV current sense range (GAIN = 1), the LSB value is $14.87\ \mu\text{V}$ and the full scale range in 60.88 mV.

Reading Current

The current register actually displays a value equivalent to a voltage across the user specified sense resistor, R_S . The co-

Step	Example
1. Determine full scale current and shunt value based on 29.68 mV across shunt at full scale. Use either: $I_{IN_MAX} = \frac{29.68\text{ mV}}{R_S}$ or: 	Example: Application with $250\ \mu\Omega$ shunt. $I_{IN_MAX} = \frac{29.68\text{ mV}}{0.25\text{ m}\Omega} = 118.7\text{A}$
2. Determine m': $m' = \frac{4095}{I_{IN_MAX}}$	 $m' = \frac{4095}{118.7\text{A}} = 34.50$
3. Determine exponent R necessary to set m' to integer value m: $10^R = \frac{m'}{m}$	Select R to provide integer value of m: $R = \log_{10} \left(\frac{34.50}{3450} \right)$ R = -2 m = 3450
4. Final values	R = -2 b = 0

Reading Input Voltage

Coefficients for VIN are consistent between read telemetry measurements (e.g., READ_VIN, READ_AVG_VIN) and warning thresholds (e.g., VIN_OV_WARN_LIMIT, VIN_UV_WARN_LIMIT). Input voltage values are read/written in Direct format with 12-bit resolution and a 6.14 mV LSB.

An example of calculating the PMBus coefficients for input voltage is shown below. Reading the auxiliary voltage (e.g. MFR_READ_VAUX, MFR_READ_AVG_VAUX) and setting the warning threshold (e.g. MFR_VAUX_UV_WARN_LIMIT) is done in similar manner with different coefficients provided in [Table 38](#).

Step	Example
1. Determine m' based on full scale analog input and full scale digital range: $m' = \frac{4095}{V_{IN_MAX}} = \frac{4095}{25.13V}$	$m' = \frac{4095}{25.13V} = 162.95$
2. Determine exponent R necessary to set m' to integer value m with desired accuracy: $10^R = \frac{m'}{m}$	Select R to provide 5 digit accuracy for the integer value of m (which would be 16295 in this example): $R = \log_{10} \left(\frac{162.95}{16295} \right)$ R = -2
3. Final values	m = 16295 R = -2 b = 0

Reading Power

The power calculation of the LM25056A is a relative power calculation meaning that full scale of the power register corresponds to simultaneous full scale values in the current register and voltage register such that the power register has the following relationship based on decimal equivalents of the register contents:

$$PIN = \frac{IIN \times VIN}{4095}$$

For this reason power coefficients will also vary depending on the shunt value and must be calculated for each application. The power LSB will vary depending on shunt value according to 374 mW/R_S for the GAIN=1 range or 182 mW/R_S for the GAIN=0 range.

Step	Example
1. Determine full scale power from known full scale of input current and input voltage $P_{IN_MAX} = V_{IN_MAX} \times I_{IN_MAX}$	Example: Application with 250 μΩ shunt. $P_{IN_MAX} = (25.13V) \times (118.7A) = 2983W$
2. Determine m': $m' = \frac{4095}{P_{IN_MAX}}$	$m' = \frac{4095}{2983W} = 1.3728$
3. Optional: Determine exponent R necessary to set m' to integer value m with desired accuracy: $10^R = \frac{m'}{m}$	Select R (in this case selected to provide 4 digit accuracy for the integer value of m): $R = \log_{10} \left(\frac{1.3728}{13728} \right)$ R = -4
4. Final values	m = 13728 R = -4 b = 0

Determining Telemetry Coefficients Empirically with Linear Fit

The coefficients for telemetry measurements and warning thresholds presented in [Table 38](#) are adequate for the majority of applications. Current and power coefficients must be calculated per application as they are dependent on the value of the sense resistor, R_S , used. [Table 39](#) provides the equations necessary for calculating the current and power coefficients for the general case. The small signal nature of the current measurement make it and the power measurement more susceptible to PCB parasitics than other telemetry channels. This may cause slight variations in the optimum coefficients (m, b, R) for converting from Direct format digital values to real-world values (e.g., amps and watts). The optimum coefficients can be determined empirically for a specific application and PCB layout using two or more measurements of the telemetry channel of interest. The current coefficients can be determined using the following method:

1. While the LM25056A is in normal operation measure the voltage across the sense resistor using kelvined test points and a high accuracy DVM while controlling the load current. Record the integer value returned by the MFR_READ_AVG_IIN command (with the MFR_SAMPLES_FOR_AVG set to a value greater than 0) for two or more voltages across the sense resistor. For best results, the individual MFR_READ_AVG_IIN measurements should span nearly the full scale range of the current (For example, voltage across R_S of 5mV and 20mV).
2. Convert the measured voltages to currents by dividing them by the value of R_S . For best accuracy the value of R_S should be measured. [Table 40](#) assumes a sense resistor value of 5 m Ω .

TABLE 40. Measurements for linear fit determination of current coefficients:

Measured voltage across R_S (V)	Measured Current (A)	READ_AVG_IIN (integer value)
0.005	1	672
0.01	2	1362
0.02	4	2743

3. Using the spreadsheet or math program of your choice determine the slope and the y-intercept of the returned by the MFR_READ_AVG_IIN command values versus the measured current. For the data shown in [Table 39](#):
MFR_READ_AVG_IIN value = slope x (Measured Current) + (y-intercept)
slope = 690.4
y-intercept = -18.5

4. To determine the 'm' coefficient, simply shift the decimal point of the calculated slope to arrive at an integer with a suitable number of significant digits for accuracy (typically 4) while staying with the range of -32768 to +32767. This shift in the decimal point equates to the 'R' coefficient. For the slope value shown above, the decimal point would be shifted to the right once hence $R = -1$.
5. Once the 'R' coefficient has been determined, the 'b' coefficient is found by multiplying the y-intercept by 10^{-R} . In this case the value of $b = -185$.
Calculated Current Coefficients:
 $m = 6904$
 $b = -185$
 $R = -1$

$$X = \frac{1}{m}(Y \times 10^{-R} - b)$$

Where:

X: the calculated "real world" value (volts, amps, watts, temperature)

m: the slope coefficient, is the two byte, two's complement integer

Y: a two byte two's complement integer received from device

b: the offset, a two byte, two's complement integer

R: the exponent, a one byte two's complement integer

The above procedure can be repeated to determine the coefficients of any telemetry channel simply by substituting measured current for some other parameter (e.g., power, voltage, etc.).

Writing Telemetry Data

There are several locations that will require writing data if their optional usage is desired. Use the same coefficients previously calculated for your application, and apply them using this method as prescribed by the PMBus™ revision section 7.2.2 "Sending a Value"

$$Y = (mX + b) \times 10^R$$

Where:

X: the calculated "real world" value (volts, amps, watts, temperature)

m: the slope coefficient, is the two byte, two's complement integer

Y: a two byte two's complement integer to send to the device

b: the offset, a two byte, two's complement integer

R: the exponent, a one byte two's complement integer

PMBus Address Lines (ADR0, ADR1, ADR2)

The three address lines are to be set high (connect to VDD), low (connect to GND), or open to select one of 27 addresses

for communicating with the LM25056A. These lines are read after the ENABLE pin is returned high, and the VDD and VREF are out of a POR condition. [Table 41](#) depicts 7-bit addresses (eighth bit is read/write bit):

TABLE 41. Device Addressing

ADR2	ADR1	ADR0	Decoded Address
Z	Z	Z	40h
Z	Z	0	41h
Z	Z	1	42h
Z	0	Z	43h
Z	0	0	44h
Z	0	1	45h
Z	1	Z	46h
Z	1	0	47h
Z	1	1	10h
0	Z	Z	11h
0	Z	0	12h
0	Z	1	13h
0	0	Z	14h
0	0	0	15h
0	0	1	16h
0	1	Z	17h
0	1	0	50h
0	1	1	51h
1	Z	Z	52h
1	Z	0	53h
1	Z	1	54h
1	0	Z	55h
1	0	0	56h
1	0	1	57h
1	1	Z	58h
1	1	0	59h
1	1	1	5Ah

SMBus Communications Timing Requirements

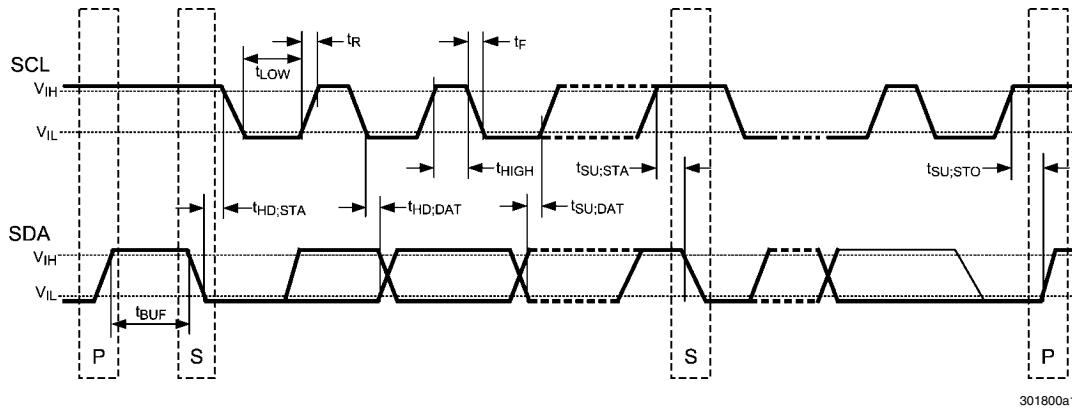

FIGURE 5. SMBus Timing Diagram

TABLE 42. SMBus Timing Definition

Symbol	Parameter	Limits		Units	Comments
		Min	Max		
f_{SMB}	SMBus Operating Frequency	10	400	kHz	
t_{BUF}	Bus free time between Stop and Start Condition	1.3		μs	
$t_{HD:STA}$	Hold time after (Repeated) Start Condition. After this period, the first clock is generated.	0.6		μs	
$t_{SU:STA}$	Repeated Start Condition setup time	0.6		μs	
$t_{SU:STO}$	Stop Condition setup time	0.6		μs	
$t_{HD:DAT}$	Data hold time	300		ns	
$t_{SU:DAT}$	Data setup time	100		ns	
$t_{TIMEOUT}$	Clock low time-out	25	35	ms	(Note 5)
t_{LOW}	Clock low period	1.5		μs	
t_{HIGH}	Clock high period	0.6		μs	(Note 6)
$t_{LOW:SEXT}$	Cumulative clock low extend time (slave device)		25	ms	(Note 7)
$t_{LOW:MEXT}$	Cumulative low extend time (master device)		10	ms	(Note 8)
t_F	Clock or Data Fall Time	20	300	ns	(Note 8)
t_R	Clock or Data Rise Time	20	300	ns	(Note 9)

Note 5: Devices participating in a transfer will timeout when any clock low exceeds the value of $t_{TIMEOUT,MIN}$ of 25 ms. Devices that have detected a timeout condition must reset the communication no later than $t_{TIMEOUT,MAX}$ of 35 ms. The maximum value must be adhered to by both a master and a slave as it incorporates the cumulative stretch limit for both a master (10ms) and a slave (25ms).

Note 6: $t_{HIGH,MAX}$ provides a simple method for devices to detect bus idle conditions.

Note 7: $t_{LOW:SEXT}$ is the cumulative time a slave device is allowed to extend the clock cycles in one message from the initial start to the stop. If a slave exceeds this time, it is expected to release both its clock and data lines and reset itself.

Note 8: $t_{LOW:MEXT}$ is the cumulative time a master device is allowed to extend its clock cycles within each byte of a message as defined from start-to-ack, ack-to-ack, or ack-to-stop.

Note 9: Rise and fall time is defined as follows:

- $t_R = (V_{ILMAX} - 0.15) \text{ to } (V_{IHMIN} + 0.15)$
- $t_F = 0.9 VDD \text{ to } (V_{ILMAX} - 0.15)$

SMBA Response

The $\overline{\text{SMBA}}$ effectively has two masks:

1. The Alert Mask Register at D8h, and
2. The ARA Automatic Mask.

The ARA Automatic Mask is a mask that is set in response to a successful ARA read. An ARA read operation returns the PMBus address of the lowest addressed part on the bus that has its $\overline{\text{SMBA}}$ asserted. A successful ARA read means that THIS part was the one that returned its address. When a part responds to the ARA read, it releases the $\overline{\text{SMBA}}$ signal. When the last part on the bus that has an $\overline{\text{SMBA}}$

set has successfully reported its address, the $\overline{\text{SMBA}}$ signal will de-assert.

The way that the LM25056A releases the $\overline{\text{SMBA}}$ signal is by setting the ARA Automatic mask bit for all fault conditions present at the time of the ARA read. All status registers will still show the fault condition, but it will not generate and $\overline{\text{SMBA}}$ on that fault again until the ARA Automatic mask is cleared by the host issuing a Clear Fault command to this part. This should be done as a routine part of servicing an $\overline{\text{SMBA}}$ condition on a part, even if the ARA read is not done. [Figure 6](#) depicts a schematic version of this flow.

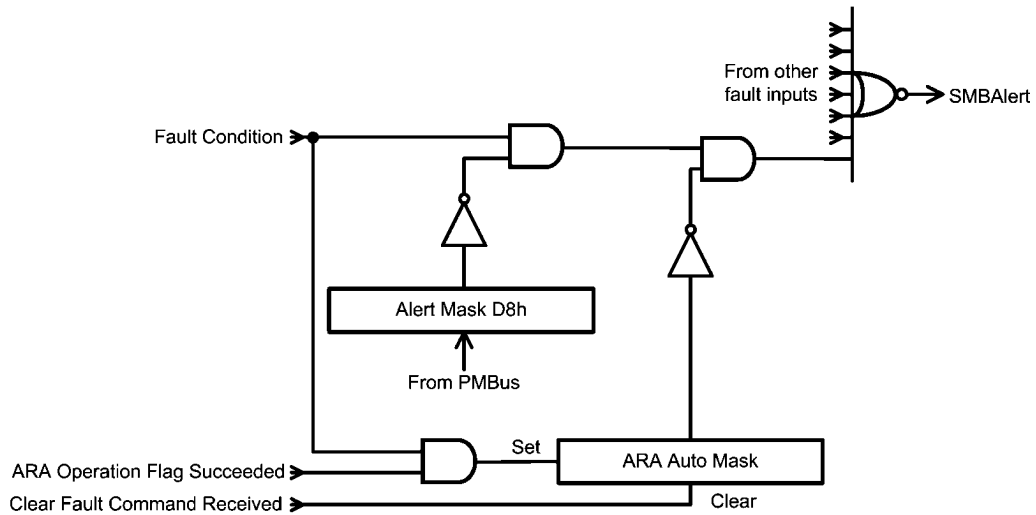

301800a0

FIGURE 6. Typical Flow Schematic for $\overline{\text{SMBA}}$ Fault

Physical Dimensions inches (millimeters) unless otherwise noted

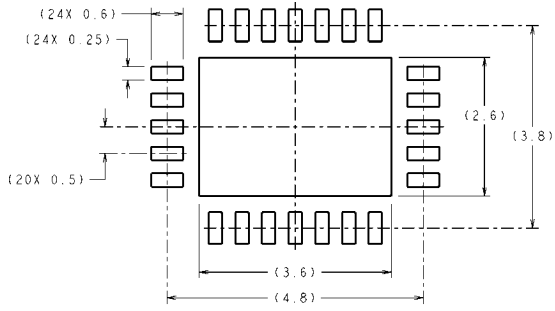

RECOMMENDED LAND PATTERN

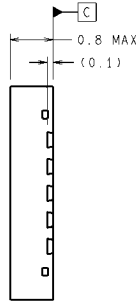
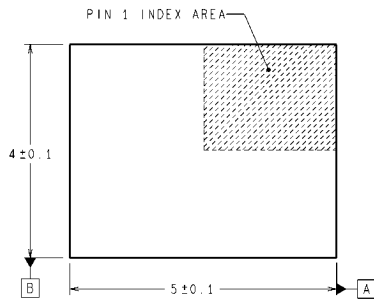

DIMENSIONS ARE IN MILLIMETERS
DIMENSIONS IN () FOR REFERENCE ONLY

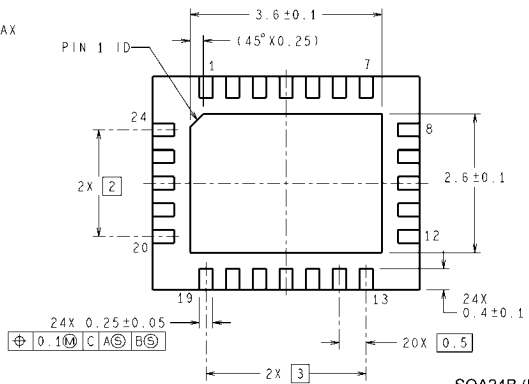

SQA24B (Rev A)

NS Package Number SQA24B

Notes

IMPORTANT NOTICE

Texas Instruments Incorporated and its subsidiaries (TI) reserve the right to make corrections, modifications, enhancements, improvements, and other changes to its products and services at any time and to discontinue any product or service without notice. Customers should obtain the latest relevant information before placing orders and should verify that such information is current and complete. All products are sold subject to TI's terms and conditions of sale supplied at the time of order acknowledgment.

TI warrants performance of its hardware products to the specifications applicable at the time of sale in accordance with TI's standard warranty. Testing and other quality control techniques are used to the extent TI deems necessary to support this warranty. Except where mandated by government requirements, testing of all parameters of each product is not necessarily performed.

TI assumes no liability for applications assistance or customer product design. Customers are responsible for their products and applications using TI components. To minimize the risks associated with customer products and applications, customers should provide adequate design and operating safeguards.

TI does not warrant or represent that any license, either express or implied, is granted under any TI patent right, copyright, mask work right, or other TI intellectual property right relating to any combination, machine, or process in which TI products or services are used. Information published by TI regarding third-party products or services does not constitute a license from TI to use such products or services or a warranty or endorsement thereof. Use of such information may require a license from a third party under the patents or other intellectual property of the third party, or a license from TI under the patents or other intellectual property of TI.

Reproduction of TI information in TI data books or data sheets is permissible only if reproduction is without alteration and is accompanied by all associated warranties, conditions, limitations, and notices. Reproduction of this information with alteration is an unfair and deceptive business practice. TI is not responsible or liable for such altered documentation. Information of third parties may be subject to additional restrictions.

Resale of TI products or services with statements different from or beyond the parameters stated by TI for that product or service voids all express and any implied warranties for the associated TI product or service and is an unfair and deceptive business practice. TI is not responsible or liable for any such statements.

TI products are not authorized for use in safety-critical applications (such as life support) where a failure of the TI product would reasonably be expected to cause severe personal injury or death, unless officers of the parties have executed an agreement specifically governing such use. Buyers represent that they have all necessary expertise in the safety and regulatory ramifications of their applications, and acknowledge and agree that they are solely responsible for all legal, regulatory and safety-related requirements concerning their products and any use of TI products in such safety-critical applications, notwithstanding any applications-related information or support that may be provided by TI. Further, Buyers must fully indemnify TI and its representatives against any damages arising out of the use of TI products in such safety-critical applications.

TI products are neither designed nor intended for use in military/aerospace applications or environments unless the TI products are specifically designated by TI as military-grade or "enhanced plastic." Only products designated by TI as military-grade meet military specifications. Buyers acknowledge and agree that any such use of TI products which TI has not designated as military-grade is solely at the Buyer's risk, and that they are solely responsible for compliance with all legal and regulatory requirements in connection with such use.

TI products are neither designed nor intended for use in automotive applications or environments unless the specific TI products are designated by TI as compliant with ISO/TS 16949 requirements. Buyers acknowledge and agree that, if they use any non-designated products in automotive applications, TI will not be responsible for any failure to meet such requirements.

Following are URLs where you can obtain information on other Texas Instruments products and application solutions:

Products

Audio	www.ti.com/audio
Amplifiers	amplifier.ti.com
Data Converters	dataconverter.ti.com
DLP® Products	www.dlp.com
DSP	dsp.ti.com
Clocks and Timers	www.ti.com/clocks
Interface	interface.ti.com
Logic	logic.ti.com
Power Mgmt	power.ti.com
Microcontrollers	microcontroller.ti.com
RFID	www.ti-rfid.com
OMAP Mobile Processors	www.ti.com/omap
Wireless Connectivity	www.ti.com/wirelessconnectivity

Applications

Automotive and Transportation	www.ti.com/automotive
Communications and Telecom	www.ti.com/communications
Computers and Peripherals	www.ti.com/computers
Consumer Electronics	www.ti.com/consumer-apps
Energy and Lighting	www.ti.com/energy
Industrial	www.ti.com/industrial
Medical	www.ti.com/medical
Security	www.ti.com/security
Space, Avionics and Defense	www.ti.com/space-avionics-defense
Video and Imaging	www.ti.com/video

TI E2E Community Home Page

e2e.ti.com

Mailing Address: Texas Instruments, Post Office Box 655303, Dallas, Texas 75265
Copyright © 2012, Texas Instruments Incorporated