

M02040-15

3.3/5V Limiting Amplifier for Applications to 2.125 Gbps

The M02040-15 is an integrated high-gain limiting amplifier. Featuring PECL outputs, the M02040-15 is useable in applications to 2.125 Gbps. Full output swing is achieved even at minimum input sensitivity. The M02040-15 can operate with a 3.3V or 5V supply.

$\overline{\text{DC_Servo}}$ supports applications requiring instantaneous output response.

The M02040-15 also includes two analog RSSI outputs proportional to either the average or peak to peak input signal and a programmable signal-level detector allowing the user to set thresholds at which the logic outputs are enabled.

Other available solutions: M02050-15 3.3/5V Limiting Amplifier for Applications to 2.5 Gbps (PECL outputs)
 M02049-15 3.3/5V Limiting Amplifier for Applications to 4.3 Gbps (CML outputs)
 M02043-15 3.3/5V Limiting Amplifier for Applications to 4.3 Gbps (CML outputs)

1.25 Gbps and 4.25 Gbps SFP reference designs available on Mindspeed.com

Applications

- 1.0625 and 2.125 Gbps Fibre Channel
- 1.25 Gbps Ethernet
- 1.25 Gbps SDH/SONET

Features

- Operates with a 3.3V or 5V supply
- 2 mV typical input sensitivity at 1.25 Gbps
- PECL outputs
- Average Receive power monitor output (RSSI_{AVG})
- Peak-to-peak Receive power monitor output (RSSI_{PP})
- On-chip DC offset cancellation circuit
- Offset cancellation circuit can be disabled for Burst mode applications
- Low power (170 mW at 3.3V)
- Output Jam function
- 16-pin 3x3 mm QFN package

Typical Applications Diagram

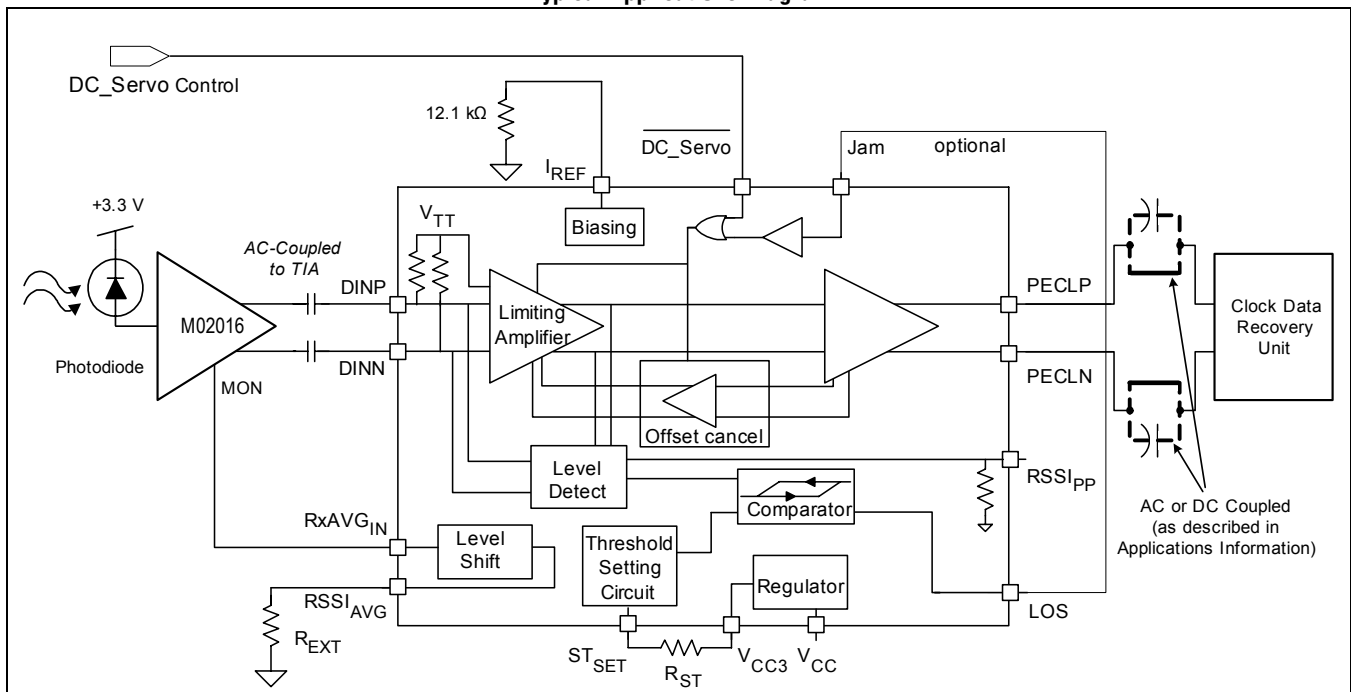

Ordering Information

Part Number	Package	Operating Temperature
M02040-15 *	M02040-15 in QFN16 package	-40 °C to 85 °C
M02040-15EVM	Evaluation board with M02040-15	-40 °C to 85 °C

* The letter "G" designator after the part number indicates that the device is RoHS-compliant. Refer to www.mindspeed.com for additional information.

Revision History

Revision	Level	Date	ASIC Revision	Description
H	Final	December 2005	-15	Clarify comments on the use of the DC_Servo pin in the applications information.
G	Final	August 2005	-15	Correct Jam connection in block diagram and typical applications figures. Correct I _{REF} figure (reference current generation).
F	Final	June 2005	-15	In the DC specifications, update R _{INDIFF} and RSSI _{avg} ; added note 1; moved RSSI _{avg} from ac specifications. In the ac specifications update V _{IN(MIN)} , V _{LOS} , DJ and tr/ta; add specifications for LOS assert and deassert. Updated R _{ST} values and the typical LOS curve (Figure 4-3 - Figure 4-5). Added typical hysteresis curve (Figure 4-6).
E	Preliminary	March 2005	-15	Update the DC specification V _{OH} . Update the ac specifications V _{IN(MIN)} , V _n , T _{LOS_ON} , and T _{LOS_OFF} . Corrected the EVM ordering number.
D	Preliminary	December 2004	-15	Update the DC specifications R _{INDIFF} and V _{IH} . Update R _{ST} values, update RSSI information. Remove peaking circuit applications information as this is not necessary for the -15 revision.

Typical Eye Diagram

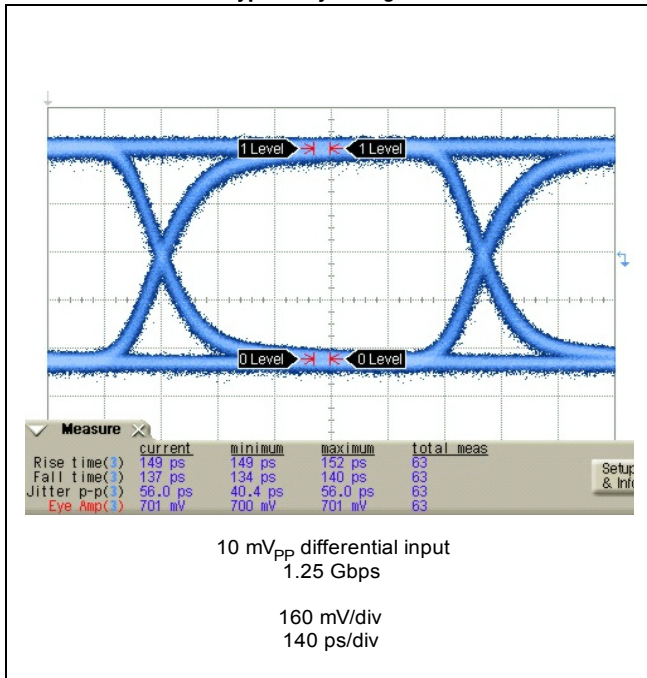

Pin Configuration

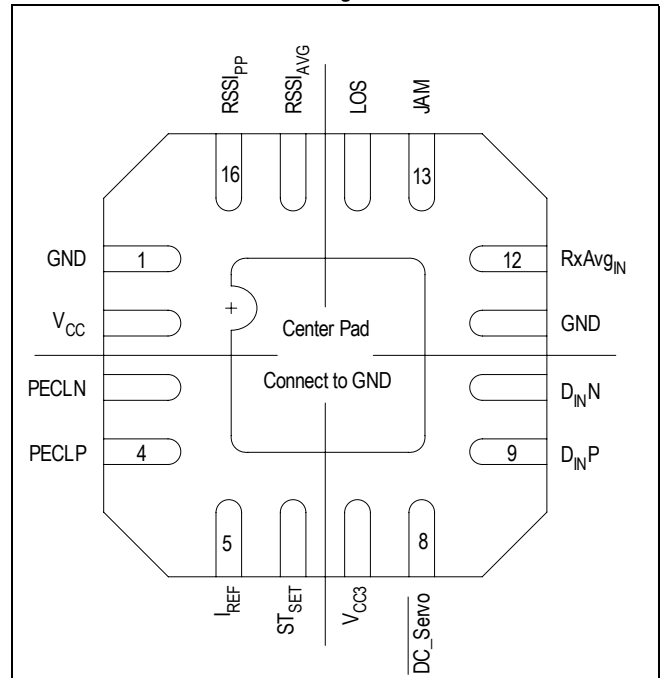



1.0 Product Specification

1.1 Absolute Maximum Ratings

These are the absolute maximum ratings at or beyond which the IC can be expected to fail or be damaged. Reliable operation at these extremes for any length of time is not implied.

NOTE:

The package bottom should be adequately grounded to ensure correct thermal performance, and it is recommended that vias are inserted through to a lower ground plane.

Table 1-1. Absolute Maximum Ratings

Symbol	Parameter	Rating	Units
V_{CC}	Power supply voltage (V_{CC} -GND)	-0.5 to +5.75	V
T_{STG}	Storage temperature	-65 to +150	°C
PECLP, PECLN	PECL Output pins voltage	$V_{CC} - 2$ to $V_{CC} + 0.4$	V
$I(PECLP)$, $I(PECLN)$	PECL Output pins maximum continuous current (delivered to load)	30	mA
$ DINP - DINN $	Data input pins differential voltage	0.80	V
DINP, DINN	Data input pins voltage meeting $ DINP - DINN $ requirement	GND to $V_{CC3} + 0.4$	V
ST_{SET}	Signal detect threshold setting pin voltage	GND to $V_{CC3} + 0.4$	V
JAM	Output enable pin voltage	GND to $V_{CC} + 0.4$	V
LOS	Status Output pins voltage	GND to $V_{CC} + 0.4$	V
$\overline{DC_Servo}$	DC_Servo disable input pin voltage	GND to $V_{CC} + 0.4$	V
I_{REF}	Current into Reference input	+0 to -120	μA
$I(RSSI_{AVG})$	Current into RSSIavg input	+0 to -3	mA
$RSSI_{PP}$	$RSSI_{PP}$ pin voltage	GND to $V_{CC3} + 0.4$	V
$I(LOS)$	Current into Loss of Signal pin	+3000 to -100	μA

1.2 Recommended Operating Conditions

Table 1-2. Recommended Operating Conditions

Parameter	Rating	Units
Power supply: (V_{CC-GND}) (apply no potential to V_{CC3}) or ($V_{CC3-GND}$) (connect V_{CC} to same potential as V_{CC3})	+5V \pm 7.5% or +3.3V \pm 7.5%	V
Junction temperature	-40 to +110	°C
Operating ambient	-40 to +85	°C

1.3 DC Characteristics

$V_{CC} = +3.3V \pm 7.5\%$ or $+5V \pm 7.5\%$, $T_A = -40^\circ\text{C}$ to $+85^\circ\text{C}$, unless otherwise noted.

Typical specifications are for $V_{CC} = 3.3V$, $T_A = 25^\circ\text{C}$, unless otherwise noted.

Table 1-3. DC Characteristics

Symbol	Parameter	Conditions	Min	Typ	Max	Units
I_{CC}	Supply Current	Outputs terminated into 50 Ω to V_{CC} (includes PECL load)	–	52	61	mA
$V_{OUTL_{pecl}}$	PECL Output Low Voltage ⁽¹⁾ (PECLP, PECLN)	Single ended; 50 Ω load to $V_{CC}-2V$	$V_{CC}-1.81$	$V_{CC}-1.71$	$V_{CC}-1.62$	V
$V_{OUTH_{pecl}}$	PECL Output High Voltage ⁽¹⁾ (PECLP, PECLN)	Single ended; 50 Ω load to $V_{CC}-2V$	$V_{CC}-1.025$	$V_{CC}-0.952$	$V_{CC}-0.88$	V
R_{INDIFF}	Differential Input Resistance	Measured between DINP and DINN	90	110	130	Ω
V_{OH_CMOS}	LOS Output High Voltage	External 4.7-10 k Ω pull up to V_{CC}	2.75	V_{CC}	–	V
V_{OL_CMOS}	LOS Output Low Voltage	External 4.7-10 k Ω pull up to V_{CC}	0	–	0.4	V
V_{IH}	Logic Input High Voltage JAM, $\overline{DC_Servo}$		2.7	–	V_{CC}	V
V_{IL}	Logic Input Low Voltage JAM, $\overline{DC_Servo}$		–	–	0.8	V
RSSlavg	Average received signal strength indicator range	$\pm 15\%$ accuracy	5	–	2000	μA

Notes:

1. Limits apply between 0°C to +85°C. Below 0 °C the minimum decreases by up to 40 mV.

1.4 AC Characteristics

$V_{CC} = +3.3V \pm 7.5\%$ or $+5V \pm 7.5\%$, $T_A = -40^\circ C$ to $+85^\circ C$, input bit rate = 1.25 Gbps 2^{23} -1 PRBS unless otherwise noted. Typical specifications are for $V_{CC} = 3.3V$, $T_A = 25^\circ C$, unless otherwise noted.

Table 1-4. AC Characteristics

Symbol	Parameter	Conditions	Min	Typ	Max	Units
$V_{IN(MIN)}$	Differential Input Sensitivity	1.25 Gbps, BER < 10^{-12}	–	2	2.75	mV
		2.125 Gbps, BER < 10^{-12}	–	3.5	5	mV
$V_{I(MAX)}$	Input Overload	BER < 10^{-12} , differential input 1.25 Gbps	1200	–	–	mV
		BER < 10^{-12} , single-ended input, 1.25 Gbps	600	–	–	mV
v_n	RMS Input Referred Noise		–	140	–	μV_{RMS}
RSSI _{pp}	Peak-to-peak received signal strength indicator range		4	–	100	mV
BW_{LF}	Small-Signal –3dB Low Frequency Cutoff	Excluding AC coupling capacitors	–	25	–	kHz
DJ	Deterministic Jitter (includes DCD)	K28.5 pattern at 1.25 Gbps, 10 mV _{pp} input	–	14	60	ps
RJ	Random Jitter	10 mV _{pp} input	–	5	–	ps _{RMS}
t_r / t_f	Data Output Rise and Fall Times	20% to 80%; outputs terminated into 50 Ω ; 10 mV _{pp} input	–	145	180	ps
V_{LOS}	LOS Programmable Range	Differential inputs	5	–	55	mV
HYS	Signal Detect Hysteresis	electrical; across LOS programmable range	2	3.5	5.5	dB
ASSERT _{LOW}	Low Input LOS Assert threshold	$R_{ST} = 7.50$ k Ω , differential input	3.5	4.9	–	mV _{pp}
DEASSERT _{LOW}	Low Input LOS De-Assert threshold	$R_{ST} = 7.50$ k Ω , differential input	–	7.8	11.3	mV _{pp}
ASSERT _{MED}	Medium Input LOS Assert threshold	$R_{ST} = 6.81$ k Ω , differential input	8.4	11.7	–	mV _{pp}
DEASSERT _{MED}	Medium Input LOS De-Assert threshold	$R_{ST} = 6.81$ k Ω , differential input	–	17.0	24.6	mV _{pp}
ASSERT _{HI}	High Input LOS Assert threshold	$R_{ST} = 6.19$ k Ω , differential input	16.6	23.2	–	mV _{pp}
DEASSERT _{HI}	High Input LOS De-Assert threshold	$R_{ST} = 6.19$ k Ω , differential input	–	33.4	48.4	mV _{pp}
T_{LOS_ON}	Time from LOS state until LOS output is asserted ⁽¹⁾	LOS assert time after 1 V _{pp} input signal is turned off; signal detect level set to 10 mV	2.3	–	80	μs
T_{LOS_OFF}	Time from non-LOS state until LOS is deasserted ⁽²⁾	LOS deassert time after input crosses signal detect level; signal detect set to 10 mV with applied input signal of 20 mV _{pp}	2.3	–	80	μs

Notes:

1. With $V_{IN_DIFF} = 1$ V_{pp}, typical times decrease as V_{IN_DIFF} decreases.
2. With $V_{IN_DIFF} = 20$ mV_{pp}, typical times decrease as V_{IN_DIFF} increases.

Figure 1-1. Data Input Requirements

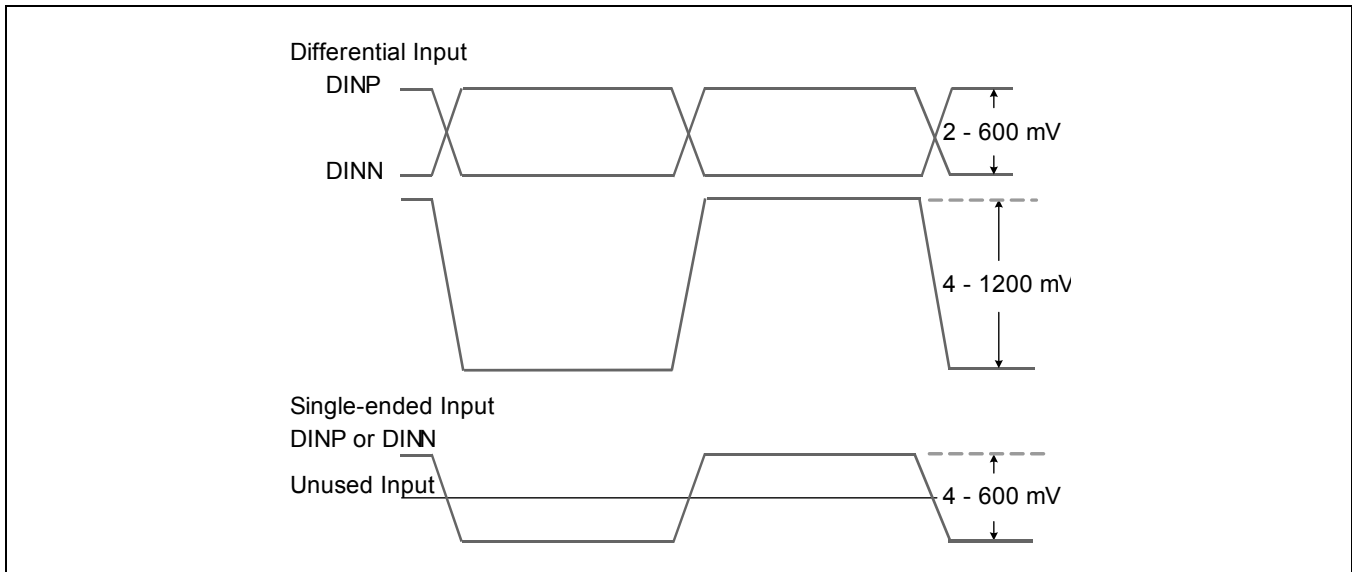

NOTE: For single-ended input connections. When connecting to the used input with AC-coupling, the unused input should be AC-coupled through 50Ω to the supply voltage of the TIA; When connecting to the used input with DC-coupling, the unused input should be DC-coupled through 50Ω to a voltage equal to the common mode level of the used input.

1.5 Typical Eye Diagrams

Figure 1-2. M02040 1.25 Gbps

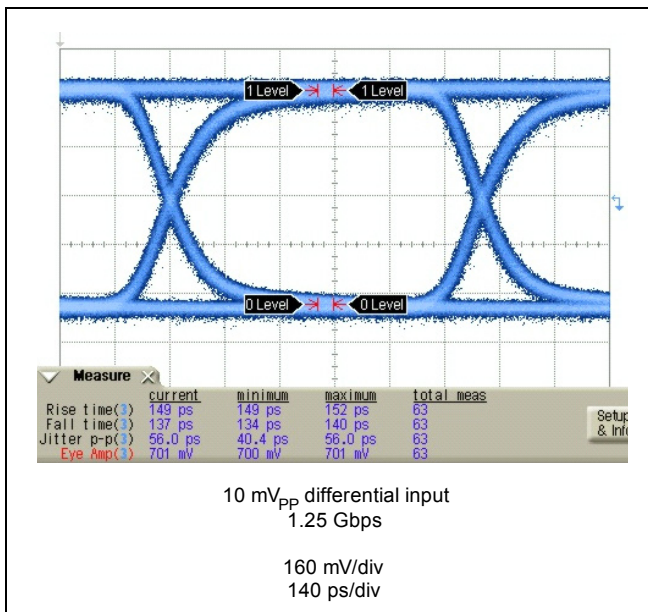
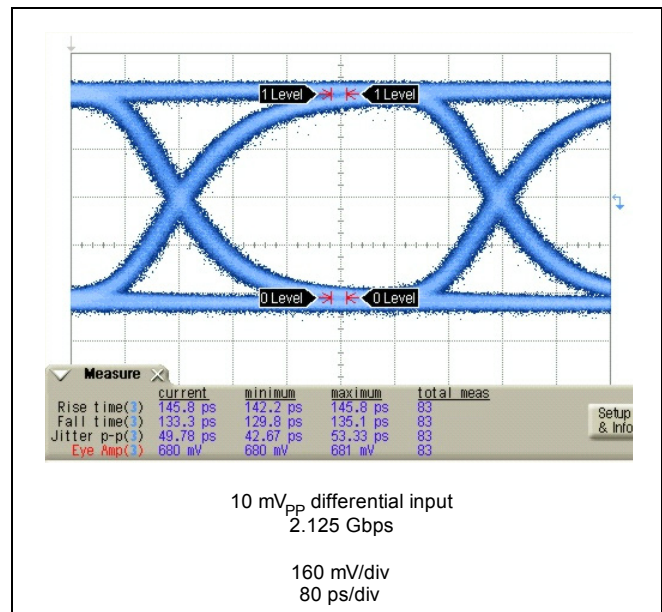

Figure 1-3. M02040 2.125 Gbps





2.0 Pin Definitions

Table 2-1. Pin Descriptions

QFN Pin#	Name	Function
1	GND	Ground.
2	V _{CC}	Power supply. Connect to either +5V or +3.3V.
3	PECLN	Inverting data output (PECL).
4	PECLP	Non-inverting data output (PECL).
5	I _{REF}	Internal LOS reference current. Must be connected to ground through a 12.1 kΩ 1% resistor.
6	ST _{SET}	Loss of signal threshold setting input. Connect a 1% resistor between this pin and V _{CC3} to set loss of signal threshold.
7	V _{CC3}	Power supply input for 3.3V applications or the output of the internally regulated 3.3V voltage when V _{CC} = 5V. Connect directly to supply for 3.3V applications (internal regulator not in use). Do not connect to power supply if V _{CC} = 5V.
8	$\overline{\text{DC_Servo}}$	DC Servo disable. When high, the DC servo circuit is disabled, allowing the limiting amplifier to be used with data that has changes quickly in amplitude and phase. Also useful for data containing significant low-speed or DC signals. When low or floating, DC servo is enabled. Internal 80 kΩ resistor to ground. Drive with a current limited source as described in Section 4.1.4 .
9	DINP	Non-inverting data input. Internally terminated with 50 Ω to V _{TT} (see Figure 3-2).
10	DINN	Inverting data input. Internally terminated with 50 Ω to V _{TT} (see Figure 3-2).
11	GND	Ground.
12	RxAVG _{IN}	Average power monitor input. Connect to monitor output of TIAs that produce a current (sink) mirror replica of the photodiode current. Leave floating if not used.
13	JAM	Output disable. When high, data outputs are disabled (with non-inverting output held high and inverting output held low). Connect to LOS output to disable outputs with loss of signal. Outputs are enabled when JAM is low or floating. Internal 150 kΩ resistor to ground.
14	LOS	Loss of signal output. Goes high when input signal falls below threshold set by ST _{SET} . Open collector TTL with internal 80 kΩ pull-up resistor to V _{CC} .
15	RSSI _{AVG}	Receiver average input power monitor. Provides a current source mirror of the current at RxAVG _{IN} . Connect a resistor to ground to set the full scale voltage to the desired level at maximum average input power.
16	RSSI _{PP}	Receiver peak-to-peak input voltage monitor. Provides a DC voltage (ground referenced) proportional to the peak-to-peak input voltage swing.
17	Center Pad	Ground to PCB for thermal dissipation.

Figure 2-1. M02040-15 Pinout

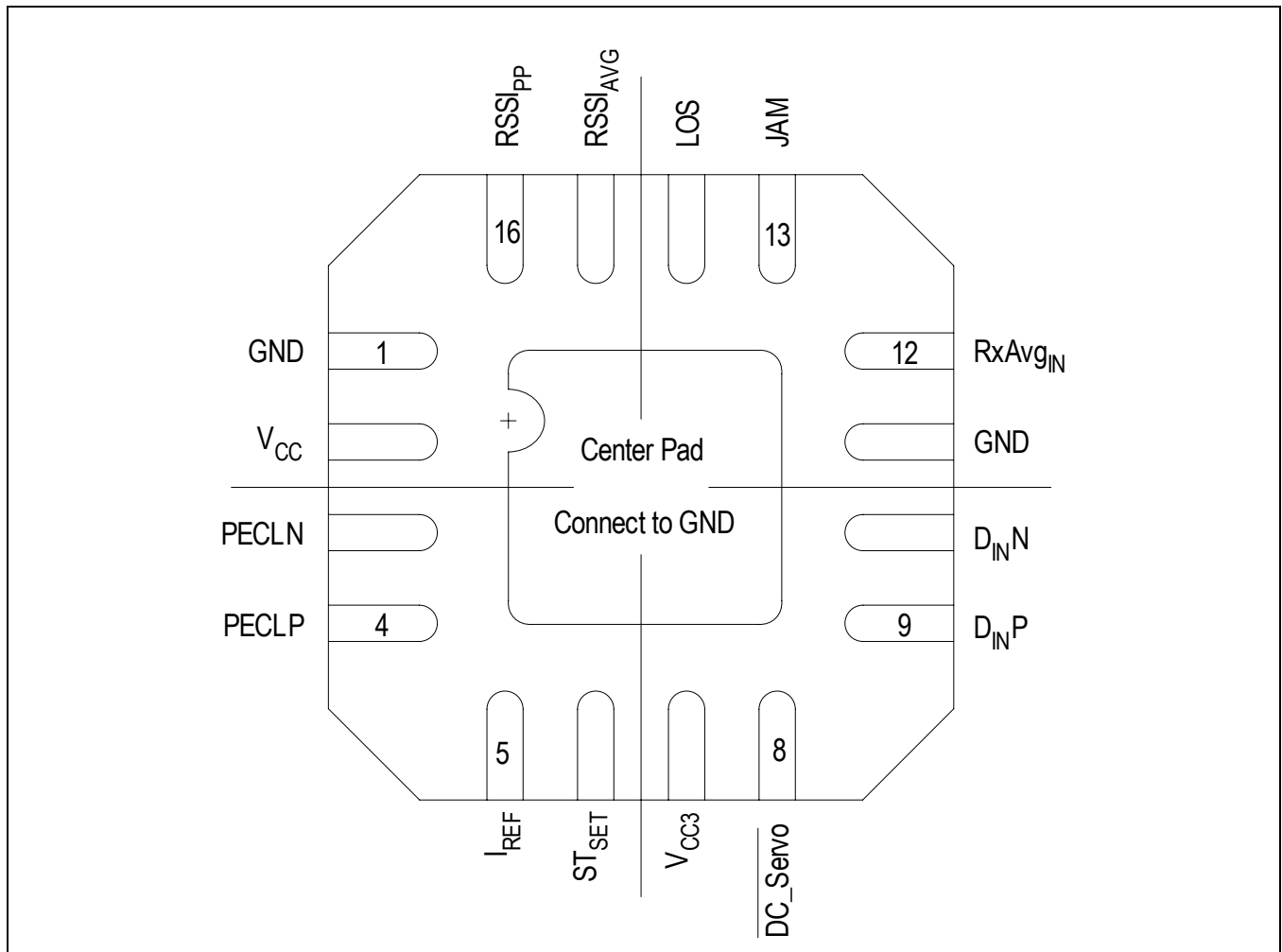



3.0 Functional Description

3.1 Overview

The M02040-15 is a high-gain limiting amplifier for applications up to 2.125 Gbps and incorporates a limiting amplifier, an input signal level detection circuit and also a fully integrated DC-offset cancellation loop that does not require any external components. The M02040-15 features PECL data outputs.

The M02040-15 provides the user with the flexibility to set the signal detect threshold. Optional output buffer disable (squelch/jam) can be implemented using the JAM input.

Figure 3-1. M02040-15 Block Diagram

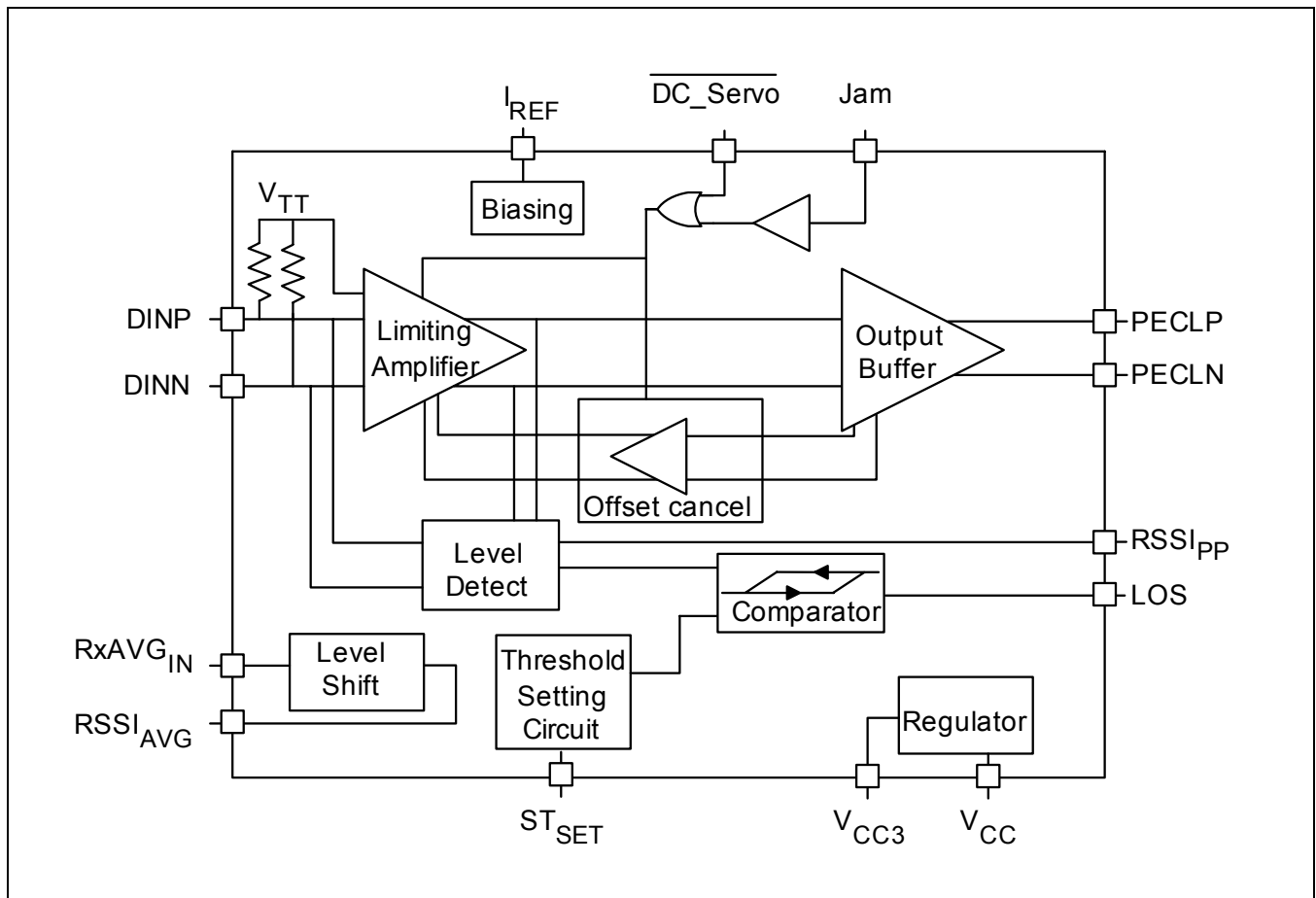

3.2 Features

- Operates with a 3.3V or 5V supply
- 2 mV typical input sensitivity at 1.25 Gbps
- PECL outputs
- Average Receive power monitor output (RSSI_{AVG})
- Peak-to-peak Receive power monitor output (RSSI_{PP})
- On-chip DC offset cancellation circuit
- Offset cancellation circuit can be disabled for Burst mode applications
- Low power (170 mW at 3.3V)
- Output Jam function
- 16-pin 3x3 mm QFN package

3.3 General Description

The M02040-15 is an integrated high-gain limiting amplifier. Featuring PECL outputs, the M02040-15 is useable in applications to 2.125 Gbps. Full output swing is achieved even at minimum input sensitivity. The M02040-15 can operate with a 3.3V or 5V supply.

DC_Servo supports applications requiring instantaneous output response.

The M02040-15 also includes two analog RSSI outputs proportional to either the average or peak to peak input signal and a programmable signal-level detector allowing the user to set thresholds at which the logic outputs are enabled.

3.3.1 Inputs

The data inputs are internally connected to V_{TT} via $50\ \Omega$ resistors, and generally need to be AC coupled. Referring to [Figure 3-2](#), the nominal V_{TT} voltage is 2.85V because of the internal resistor divider to V_{CC3} , which means this is the DC potential on the data inputs. See the applications information section for further details on choosing the AC-coupling capacitor.

Figure 3-2. CML Data Inputs

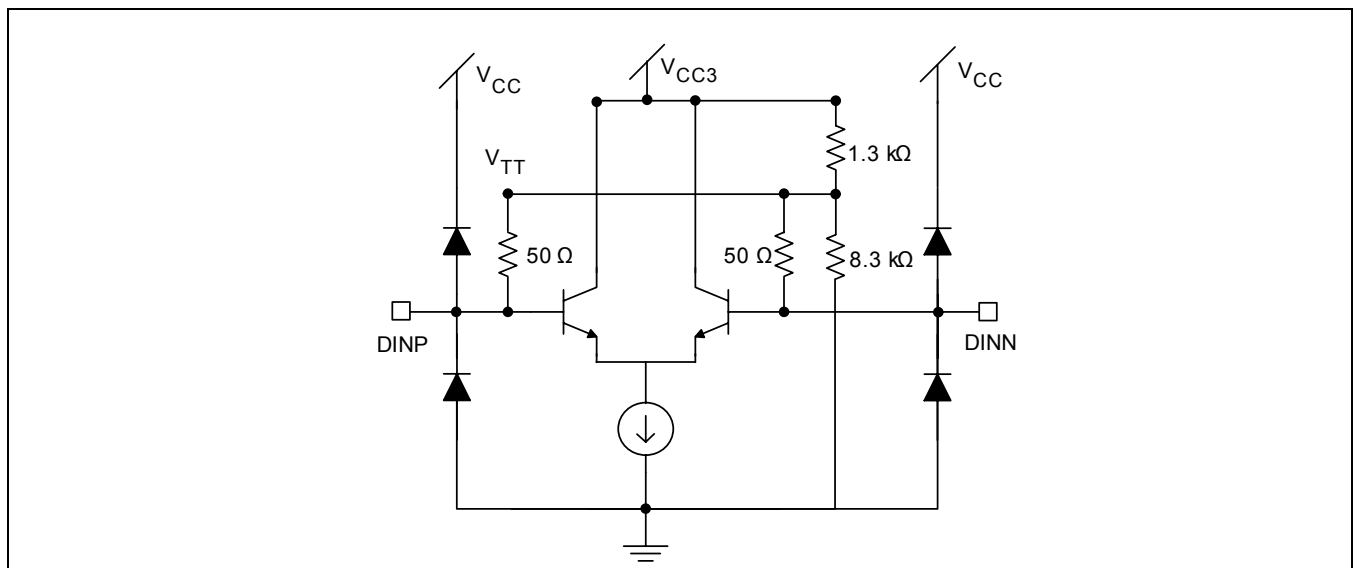

3.3.2 DC Offset Compensation

The M02040-15 contains an internal DC autozero circuit that can remove the effect of DC offsets without using external components. This circuit is configured such that the feedback is effective only at frequencies well below the lowest frequency of interest. The low frequency cut off is typically 25 kHz.

3.3.3 Data Outputs

The M02040-15 features 100k/300k PECL compliant outputs as shown in [Figure 3-3](#). The outputs may be terminated using any standard AC or DC-coupling PECL termination technique. AC-coupling is used in applications where the average DC content of the data is zero. The advantage of this approach is lower power consumption, no susceptibility to DC drive and compatibility with non-PECL interfaces.

Figure 3-3. PECL Data Outputs

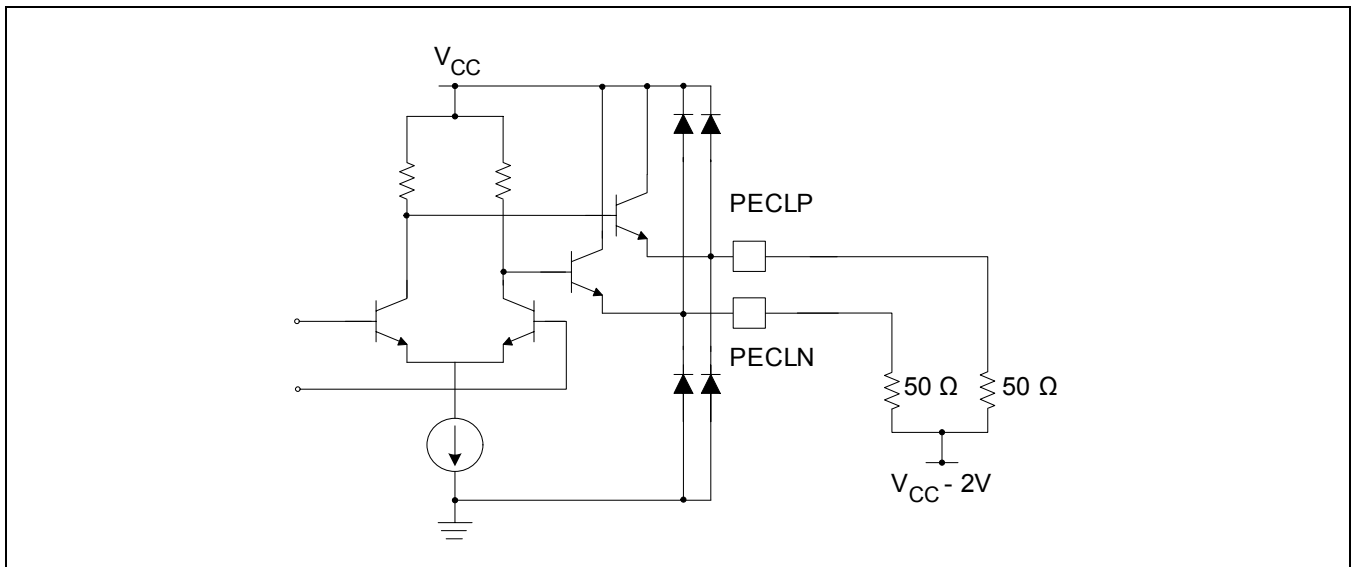

3.3.4 Loss of Signal (LOS)

The M02040-15 features input signal level detection over an extended range. Using an external resistor, R_{ST} , between pin ST_{SET} and V_{CC3} (Figure 3-5) the user can program the input signal threshold. The signal detect status is indicated on the LOS output pin shown in Figure 3-4. The LOS signal is active when the signal is below the threshold value. The signal detection circuitry has the equivalent of 3.5 dB (typical) electrical hysteresis.

Figure 3-4. LOS Output

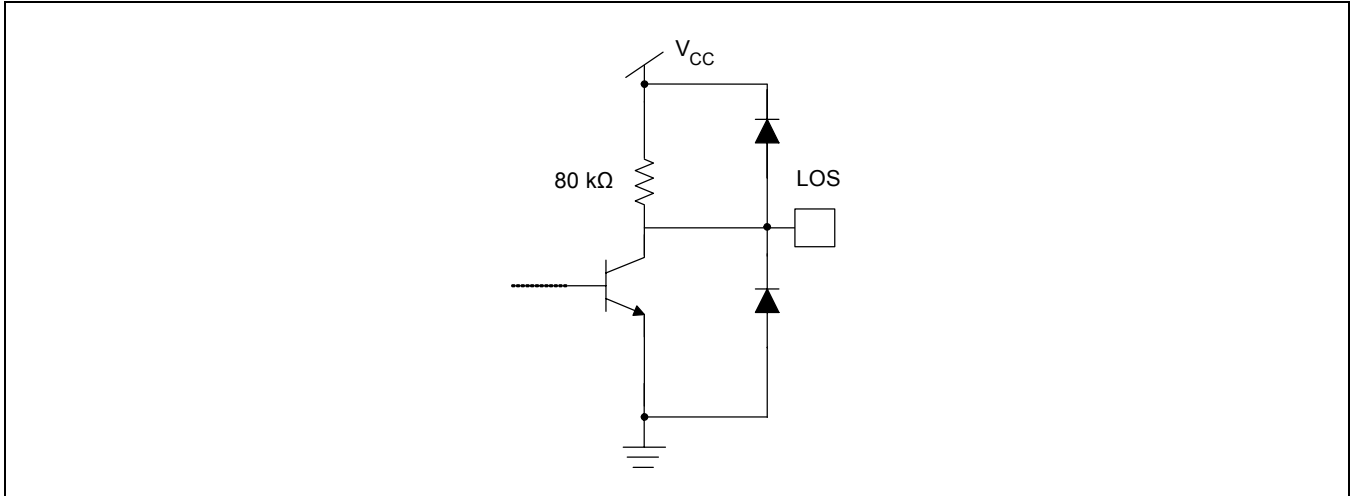

R_{ST} establishes a threshold voltage at the ST_{SET} pin as shown in Figure 3-5. Internally, the input signal level is monitored by the Level Detector (which also outputs the $RSSI_{PP}$ voltage). As described in the $RSSI_{PP}$ section, this voltage is proportional to the input signal peak to peak value. The voltage at ST_{SET} is internally compared to the signal level from the Level Detector. When the Level Detect voltage is less than $V_{(STSET)}$, LOS is asserted and will stay asserted until the input signal level increases by a predefined amount of hysteresis. When the input level increases by more than this hysteresis above $V_{(STSET)}$, LOS is deasserted. See the applications information section for the selection of R_{ST} .

Note that ST_{SET} can be left open if the loss of signal detector function is not required. In this case LOS would be low.

Figure 3-5. ST_{SET} Input

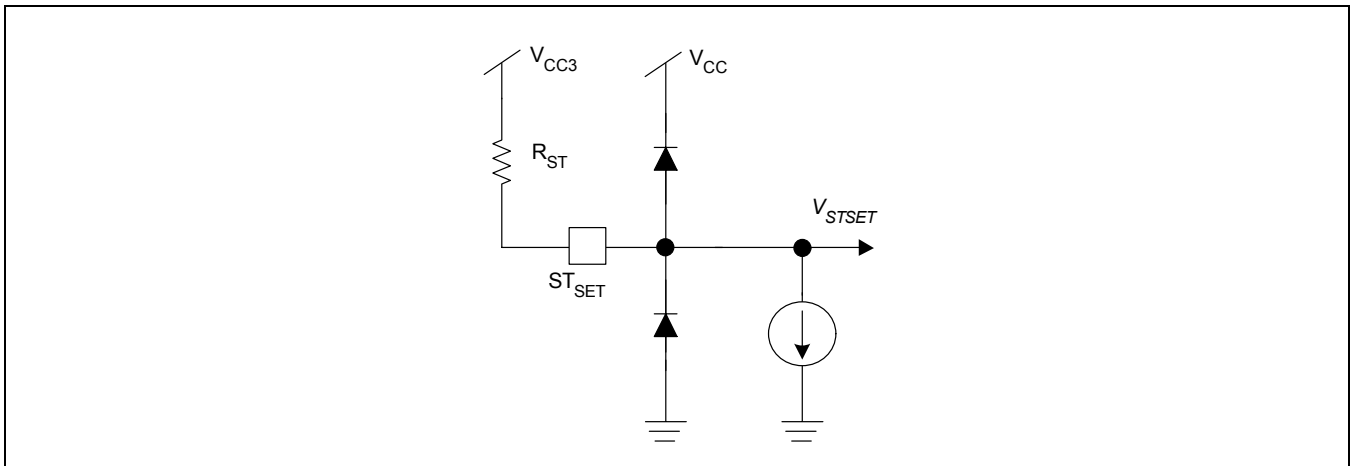

3.3.5 Peak to Peak Received Signal Strength Indicator (RSSI_{PP})

The RSSI_{PP} output voltage is logarithmically proportional to the peak to peak level of the input signal. It is not necessary to connect an external capacitor to this output. Internally, the RSSI voltage is compared with a user selectable reference to determine loss of signal as described in the previous section.

Figure 3-6. RSSI_{PP} Output

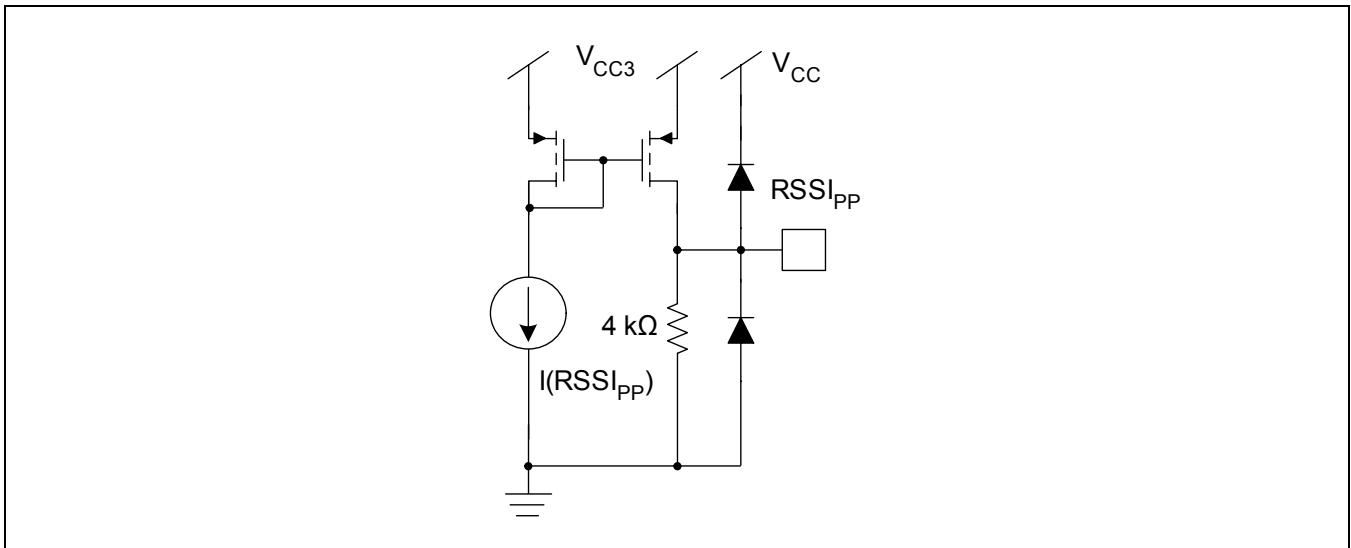

Figure 3-7. Typical RSSI_{PP} Transfer Function

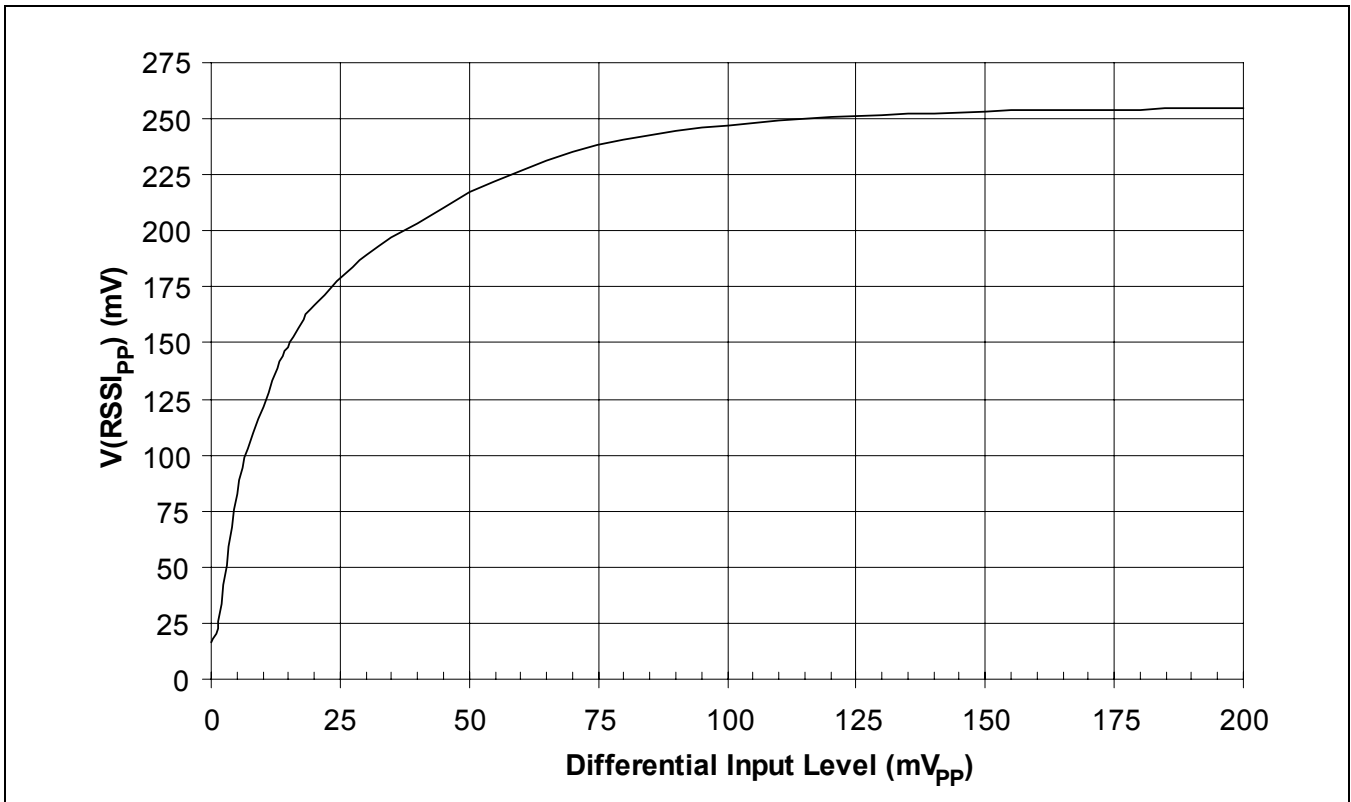

Figure 3-8. Typical $RSSI_{PP}$ Transfer Function (Low Input Level Range)

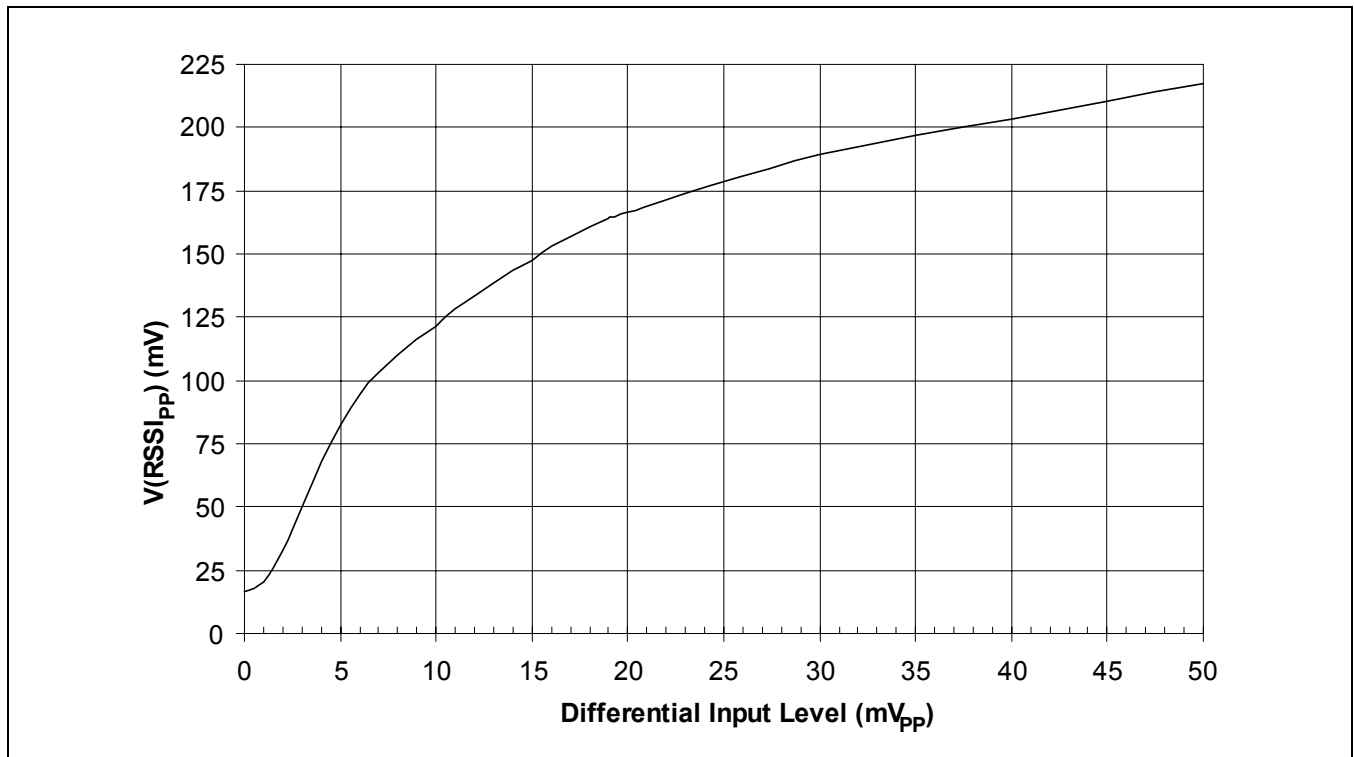
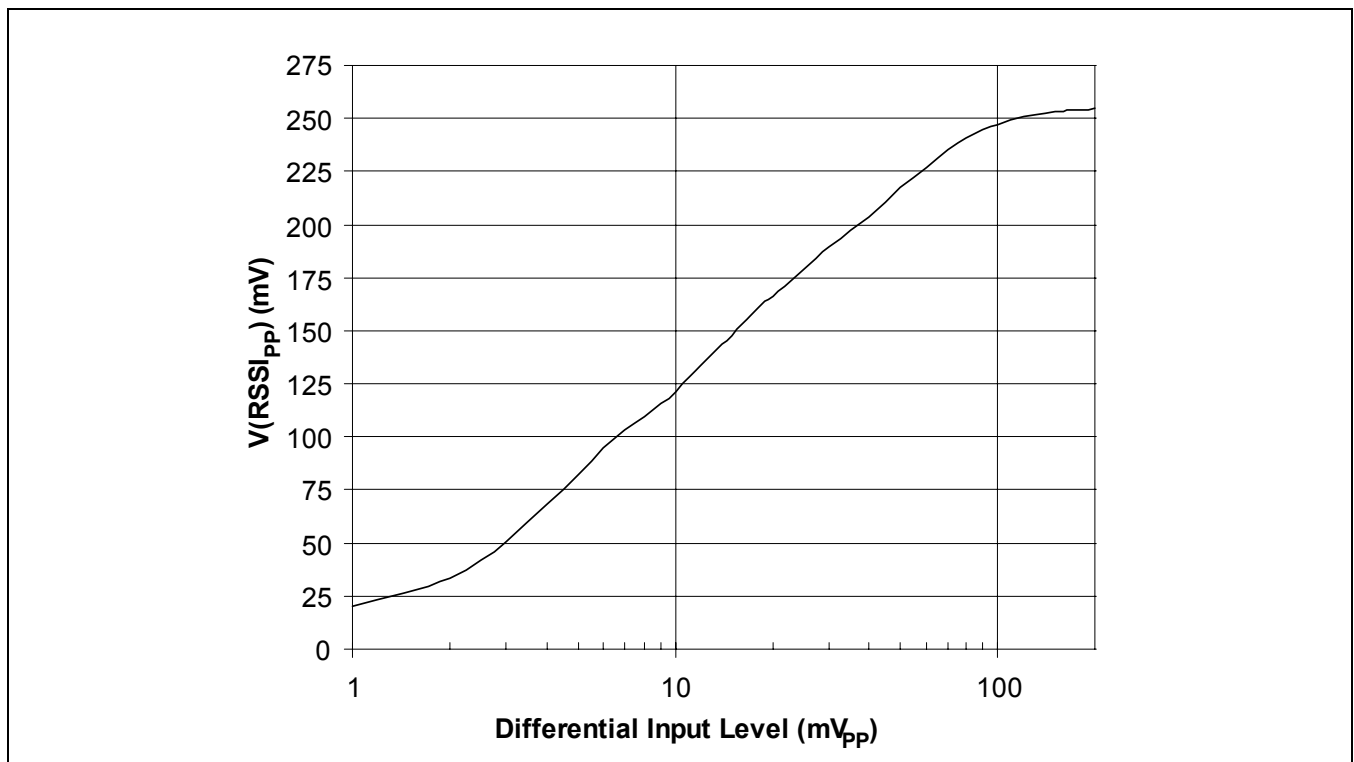

Figure 3-9. Typical $RSSI_{PP}$ Transfer Function (Log Scale)



3.3.6 JAM Function

When asserted, the active high power down (JAM) pin forces the outputs to a logic “one” state. This ensures that no data is propagated through the system. The loss of signal detection circuit can be used to automatically force the data outputs to a high state when the input signal falls below the threshold. The function is normally used to allow data to propagate only when the signal is above the user’s bit-error-rate requirement. It therefore inhibits the data outputs toggling due to noise when there is no signal present (“squelch”).

In order to implement this function, LOS should be connected to the JAM pin shown in [Figure 3-10](#), thus forcing the data outputs to a logic “one” state when the signal falls below the threshold.

3.3.7 DC Servo Function

When the $\overline{\text{DC_Servo}}$ pin (shown in [Figure 3-10](#)) is driven high, the M02040-15 internal DC servo loop (described in [Section 3.3.2](#)) is disabled and the part will pass DC signals. This is useful when using signals with an unequal mark and space ratio, when the signal contains significant low speed or DC information, or when the input to the part must be DC coupled to a TIA that will change its common mode output voltage very quickly. Note that when the servo loop is disabled, any offset from the TIA or within the M02040-15 will cause DCD at the output which is a function of the offset and the input PP amplitude (large offsets and low amplitude input signals create the largest output DCD). When this pin is tied low or floating the 2040-15 servo loop operates as described in [Section 3.3.2](#).

Figure 3-10. JAM and $\overline{\text{DC_Servo}}$ Input

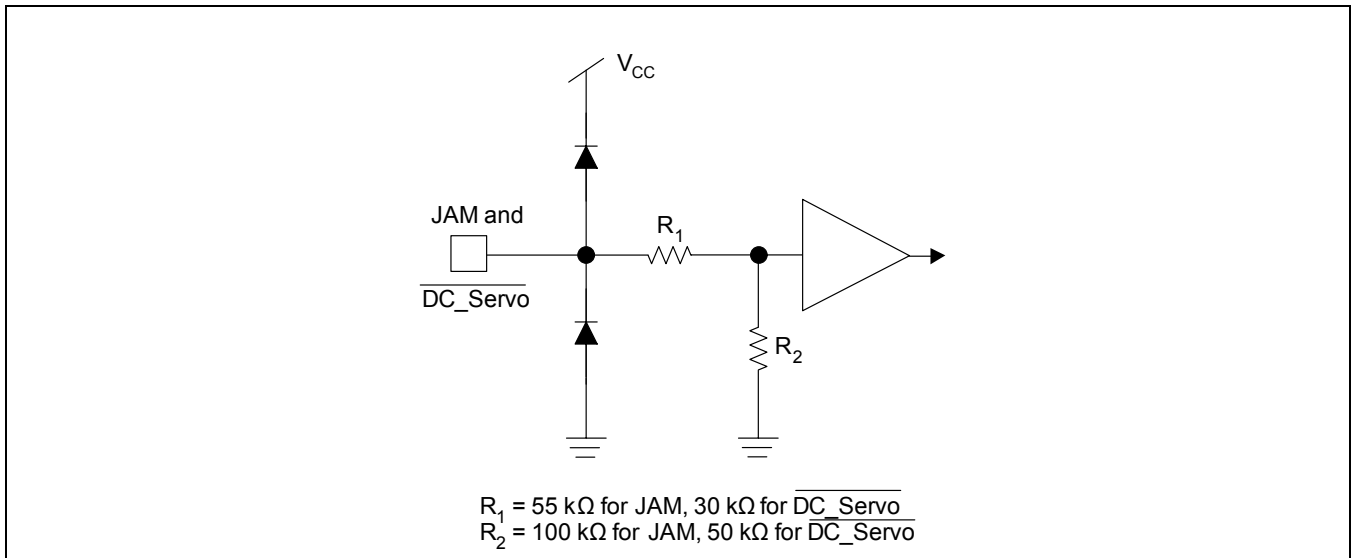

3.3.8 Average Received Signal Strength Indicator (RSSI_{AVG})

The RSSI_{AVG} output current is a mirrored version of the RxAVG_{IN} current from compatible TIAs. It sources rather than sinks the current making it compatible with DDMI type interfaces.

Figure 3-11. RSSI_{AVG} Output

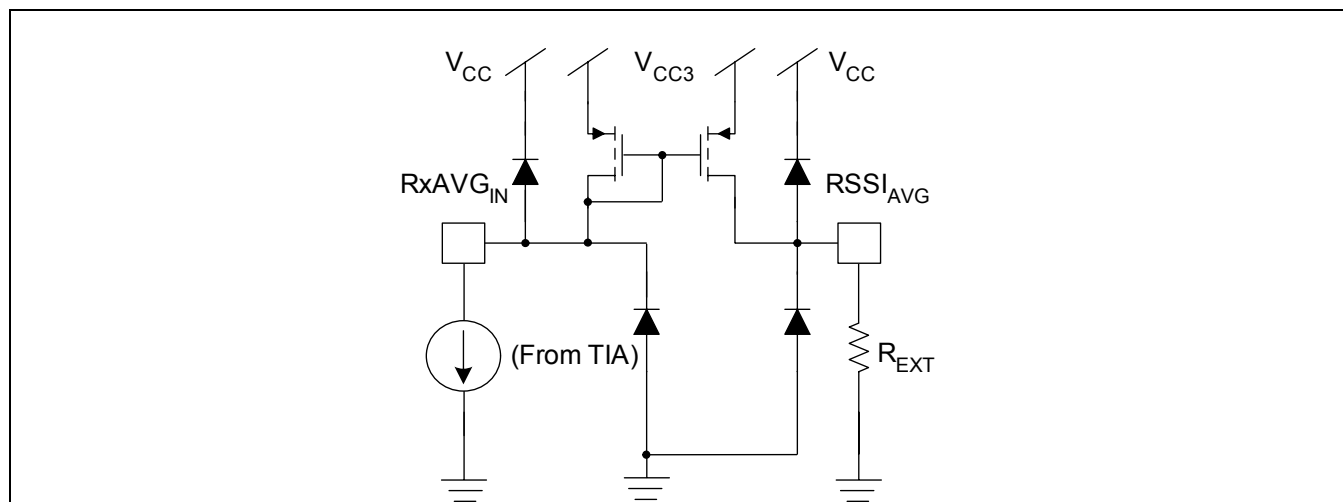

3.3.9 Voltage Regulation

The M02040-15 contains an on-chip voltage regulator to allow both 5V and 3.3V operation. When used at 5V, the on-chip regulator is enabled and the digital inputs and outputs are compatible with TTL 5V logic levels.

4.1.1 Reference Current Generation

The M02040-15 contain an accurate on-chip bias circuit that requires an external 12.1 kΩ 1% resistor, R_{REF}, from pin I_{REF} to ground to set the LOS threshold voltage at ST_{SET} precisely.

Figure 4-2. Reference Current Connection

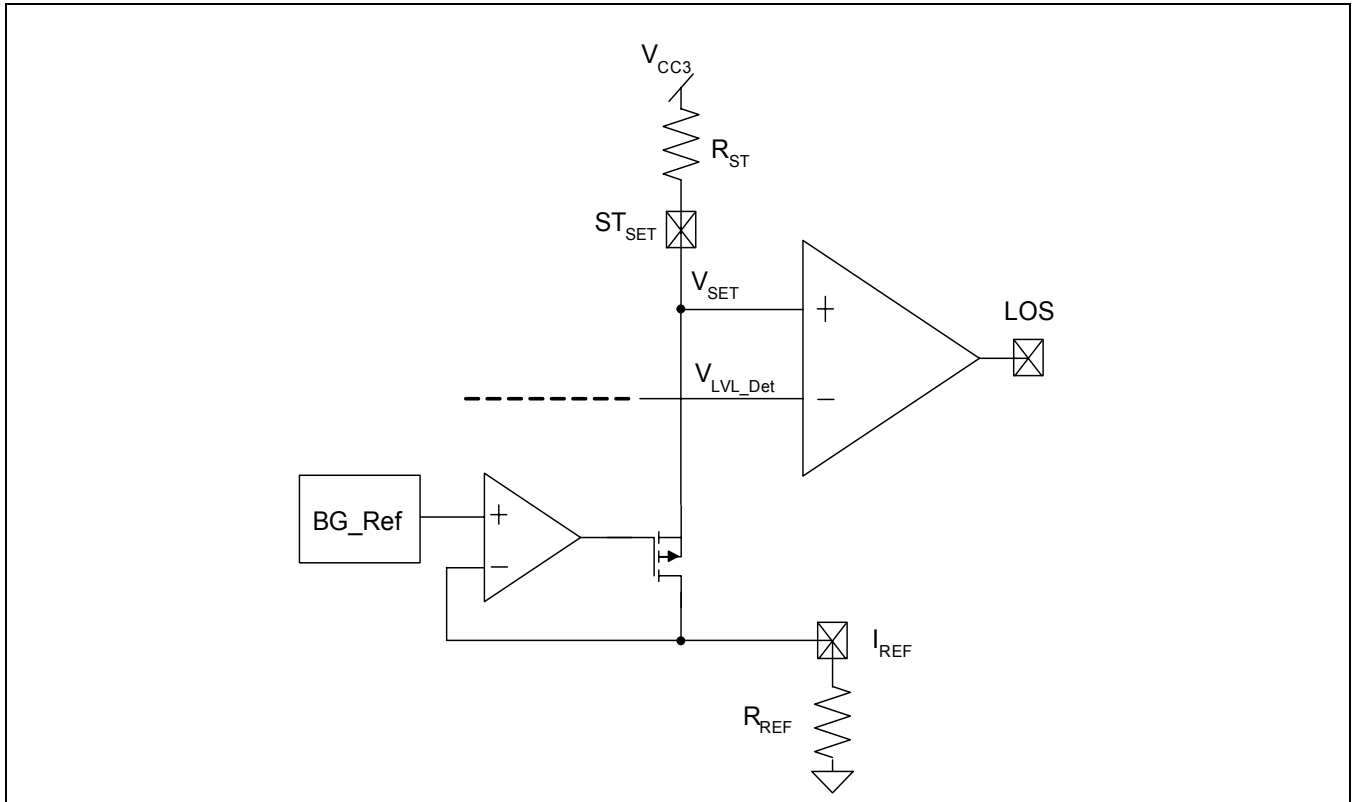

4.1.2 Connecting V_{CC} and V_{CC3}

For 5V operation, the V_{CC} pin is connected to an appropriate 5V ± 7.5% supply. No potential should be applied to the V_{CC3} pin. The only connection to V_{CC3} should be R_{ST} as shown in Figure 3-5.

When V_{CC} = 5V all logic outputs and the data outputs are 5V compatible while the CML data inputs are still referenced to 3.3V from the internal regulator (see Figure 3-2). For low power operation, V_{CC} and V_{CC3} should be connected to an appropriate 3.3V ± 7.5% supply. In this case all I/Os are 3.3V compatible.

4.1.3 Choosing an Input AC-Coupling Capacitor

When AC-coupling the input the coupling capacitor should be of sufficient value to pass the lowest frequencies of interest, bearing in mind the number of consecutive identical bits, and the input resistance of the part. For Ethernet or Fibre Channel data, a good rule of thumb is to choose a coupling capacitor that has a cut-off frequency less than 1/(1,000) of the input data rate. For example, for 1.25 Gbps data, the coupling capacitor should be chosen as:

$$f_{\text{CUTOFF}} \leq (1.25 \times 10^9 / 1 \times 10^3) = 1.25 \times 10^6$$

The -3 dB cutoff frequency of the low pass filter at the 50 Ω input is found as:

$$f_{3dB} = 1 / (2 * \pi * 50 \Omega * C_{AC})$$

so solving for C where $f_{3dB} = f_{CUTOFF}$

$$C_{AC} = 1 / (2 * \pi * 50 \Omega * f_{CUTOFF}) \quad \text{EQ.1}$$

and in this case the minimum capacitor is 2.5 nF.

For 2.125 Gbps Fibre Channel, this results in a minimum capacitor of 1.5 nF.

4.1.3.1 Multirate applications down to 155 Mbps

In this case, the input coupling capacitor needs to be large enough to pass 15 kHz ($155 \times 10^6 / 10,000$) which results in a capacitor value of 0.2 μ F. However, because this low pass frequency is close to the 25 kHz low pass frequency of the internal DC servo loop, it is preferable to use a larger input coupling capacitor such as 1 μ F which provides an input cutoff frequency of 3.1 kHz. This separates the two poles sufficiently to allow them to be considered independent. This capacitor should also have a 10 nF capacitor in parallel to pass the higher frequency data (in the multirate application) without distortion.

In all cases, a high quality coupling capacitor should be used as to pass the high frequency content of the input data stream.

4.1.4 Using DC_Servo

When the DC_Servo pin (shown in [Figure 3-10](#)) is tied high, the M02040-15 disables the internal servo loop which allows the device to pass signals with DC content resulting in instantaneous response to changes in the input data stream (e.g. data amplitude and phase). However, there is no correction for limit amp offset when the servo loop is disabled which results in degraded sensitivity and increased duty cycle distortion.

Because of the nature of the ESD structure on this pin, if it is driven by a device with I_{OL} or $I_{OH} > 2$ mA then a 1 k Ω to 10 k Ω resistor should be used in series with the DC_Servo pin. If the internal servo loop is never going to be disabled, DC_Servo should be connected to ground using a 1k Ω to 10k Ω resistor. If the internal servo loop is going to be continuously disabled, the DC_Servo pin should be connected to V_{CC} using a 1 k Ω to 10 k Ω resistor.

4.1.5 Using $R_{SSI_{AVG}}$

As shown in the typical applications circuit (front page), when interfacing to a TIA that features a “MON” output such as the M02010 or M02016, the M02040-15 can reference the current sunk into the TIA “MON” output and produce a proportional current at the 2040 $R_{SSI_{AVG}}$ output. The current is sourced into resistor R_{EXT} to ground creating a voltage suitable for DDMI applications. R_{EXT} should be chosen as:

$$R_{EXT} = 1 / (\text{maximum current into } R_{SSI_{AVG}}) \quad \text{EQ.2}$$

This keeps the voltage at $R_{SSI_{AVG}}$ between 0 and 1 V.

4.1.6 Setting the Signal Detect Level

Using Figure 4-3, the value for R_{ST} is chosen to set the LOS threshold at the desired value. The resulting hysteresis is also shown in Figure 4-3.

From Figure 4-3, it is apparent that small variations in R_{ST} cause significant variation in the LOS threshold level, particularly for low input signal levels. This is because of the logarithmic relationship between the RSSI voltage and the input signal level. It is recommended that a 1% resistor be used for R_{ST} and that allowance is provided for LOS variation, particularly when the LOS threshold is near the sensitivity limit of the M02040-15.

Example R_{ST} resistor values are given in Table 4-1.

Table 4-1. Typical LOS Assert and De-assert Levels for Various 1% R_{ST} Resistor Values

R_{ST} (k Ω)	VIN (mV pp) differential	
	LOS Assert	LOS De-Assert
7.50	4.9	7.8
6.81	11.7	17.0
6.19	23.2	33.4
5.49	55.0	77.3

Figure 4-3. Typical Loss of Signal Characteristic (Full Input Signal Range)

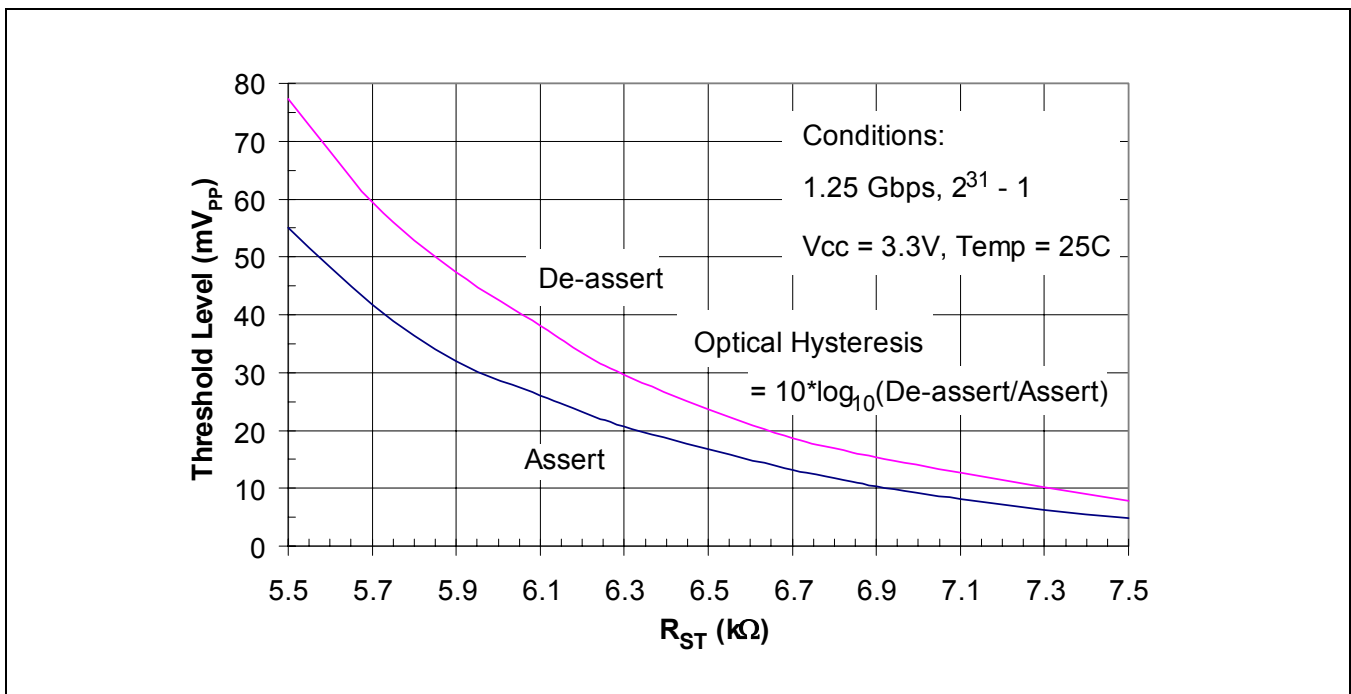

Figure 4-4. Typical Loss of Signal Characteristic (Low Input Signal Range)

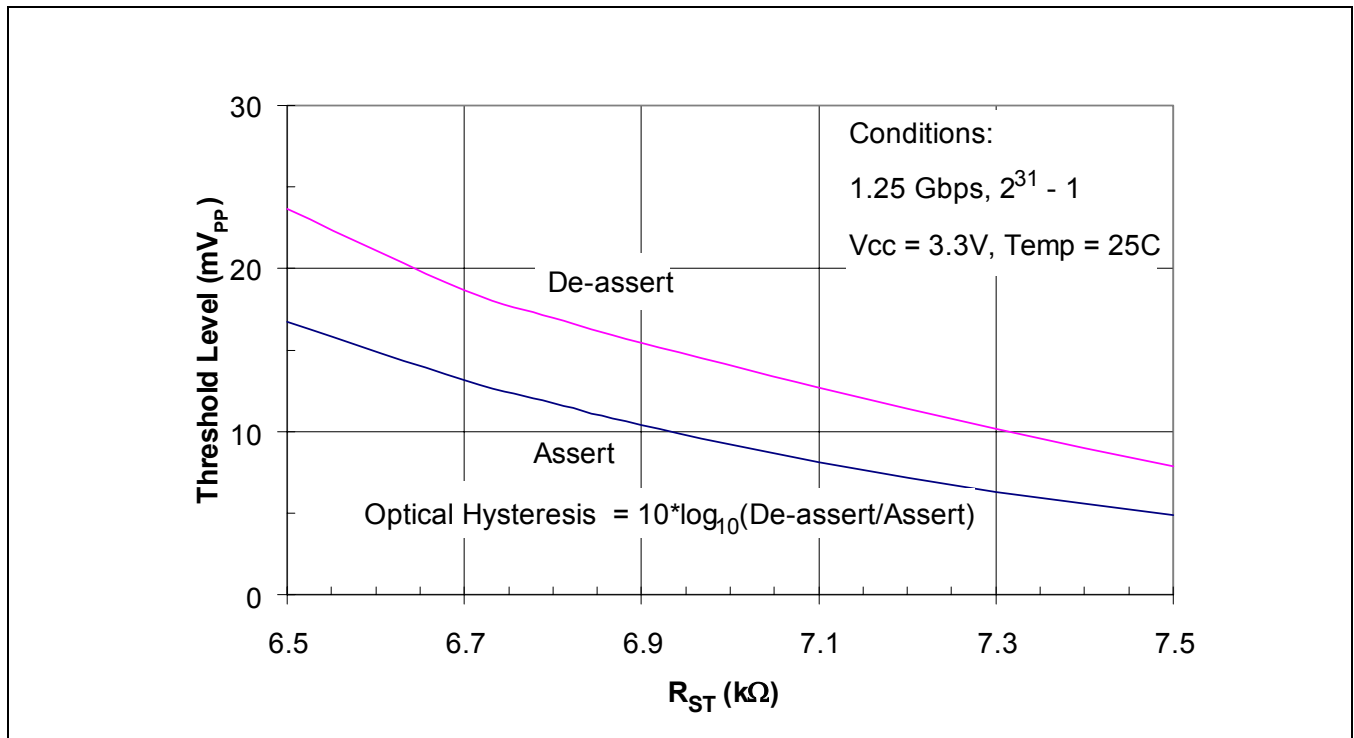

Figure 4-5. Typical Loss of Signal Characteristic (High Input Signal Range)

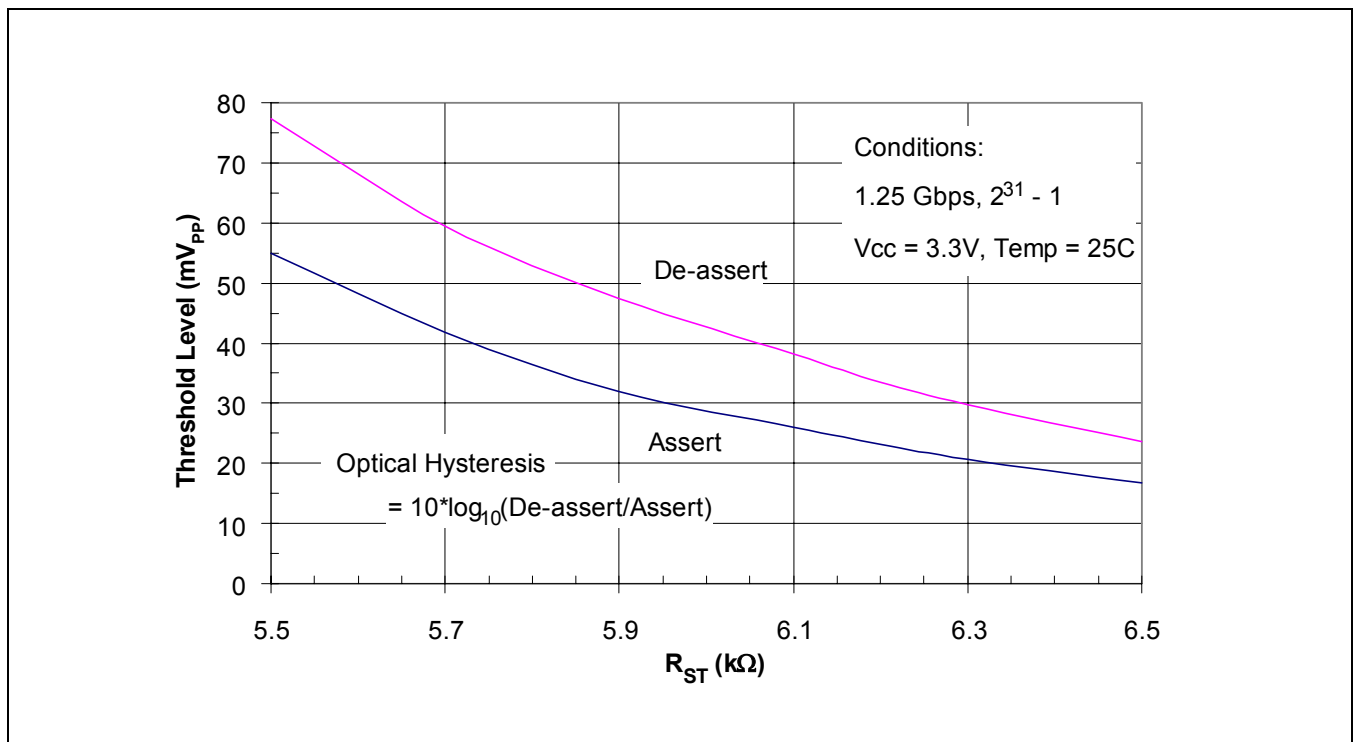
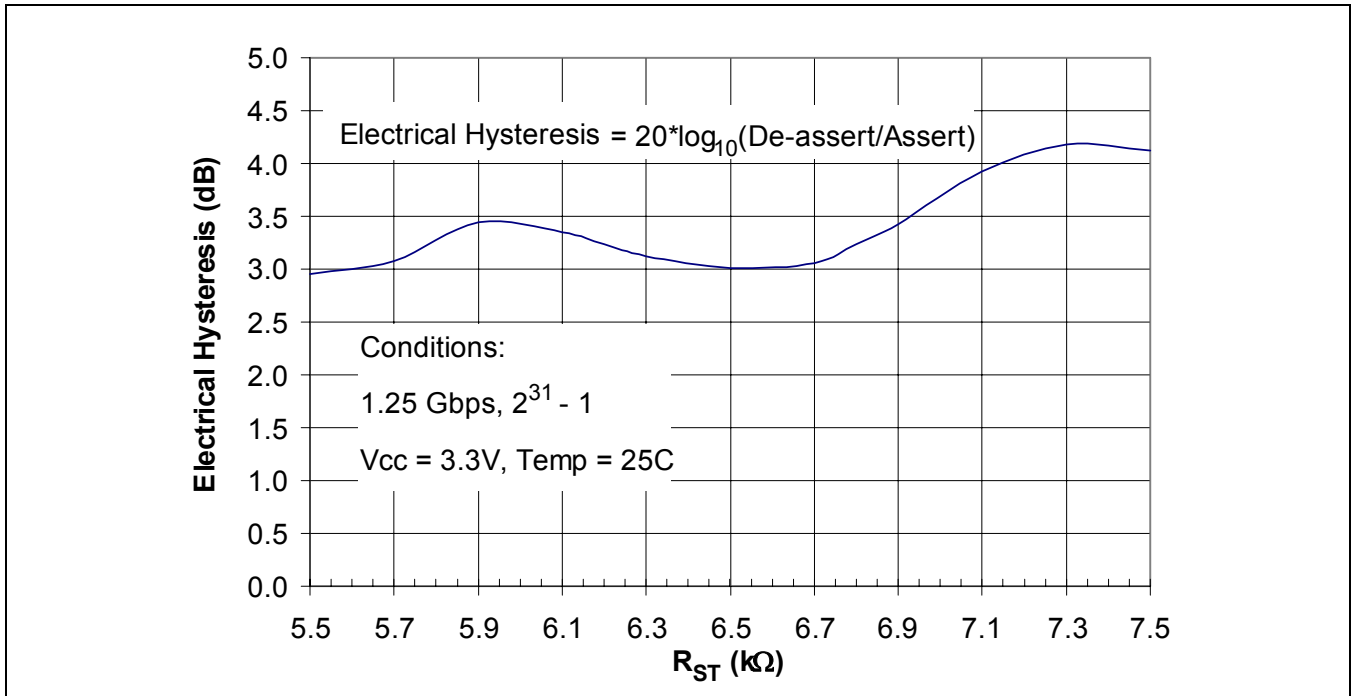

Figure 4-6. Typical Loss of Signal Hysteresis Characteristic (Full Input Signal Range)



4.1.7 PECLP and PECLN Termination

The outputs of the M02040-15 are PECL compatible and any standard AC or DC-coupling termination technique can be used. Figure 4-7 and Figure 4-8 illustrate typical AC and DC terminations.

AC-coupling is used in applications where the average DC content of the data is zero e.g. SONET. The advantage of this approach is lower power consumption, no susceptibility to DC drift and compatibility with non-PECL interfaces. Figure 4-7 shows the circuit configuration and Table 4-2 lists the resistor values. If using transmission lines other than 50 Ω, the shunt terminating resistance Z_T should equal twice the impedance of the transmission line (Z_0).

DC-coupling can be used when driving PECL interfaces and has the advantage of a reduced component count. A Thevenin termination is used at the receive end to give a 50 Ω load and the correct DC bias. Figure 4-8 shows the circuit configuration and Table 4-2 the resistor values.

Alternatively, if available, terminating to $V_{CC} - 2V$ as shown in Figure 4-9 has the advantage that the resistance value is the same for 3.3 V and 5 V operation and it also has performance advantages at high data rates.

Table 4-2. PECL Termination Resistor Values

Supply	Output Impedance	$R_{PULL-DOWN}$	Z_T	R_{TA} / R_{TB}	R_T / R_B
5V	50 Ω	270 Ω	100 Ω	2.7 kΩ / 7.8 kΩ	82 Ω / 130 Ω
3.3V	50 Ω	150 Ω	100 Ω	2.7 kΩ / 4.3 kΩ	130 Ω / 82 Ω

Figure 4-7. AC-Coupled PECL Termination

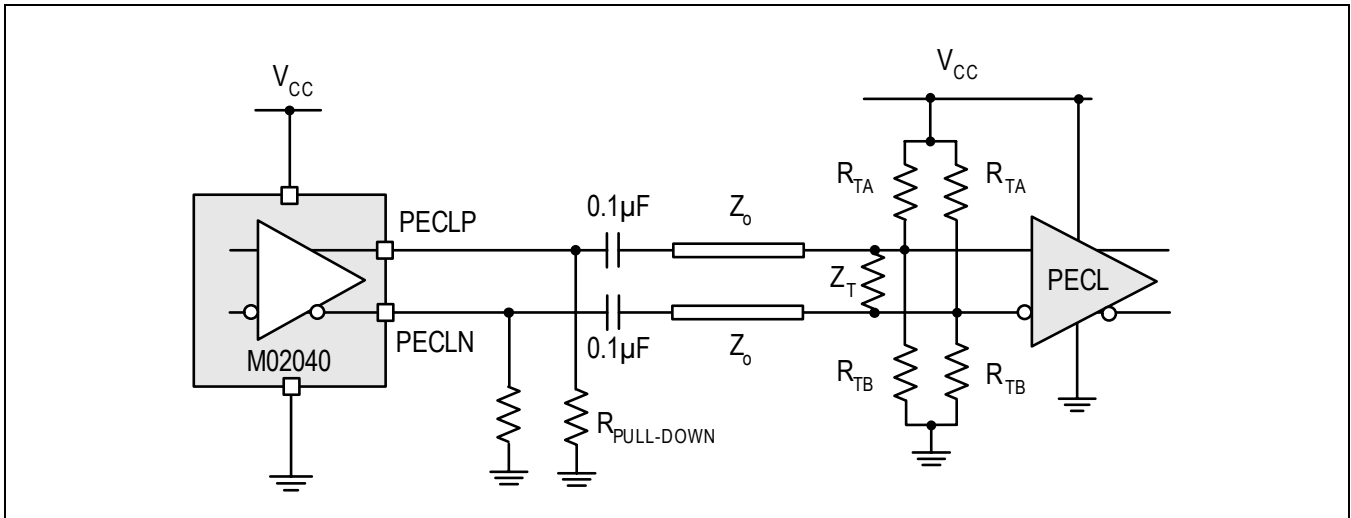

Figure 4-8. DC-Coupled PECL Termination

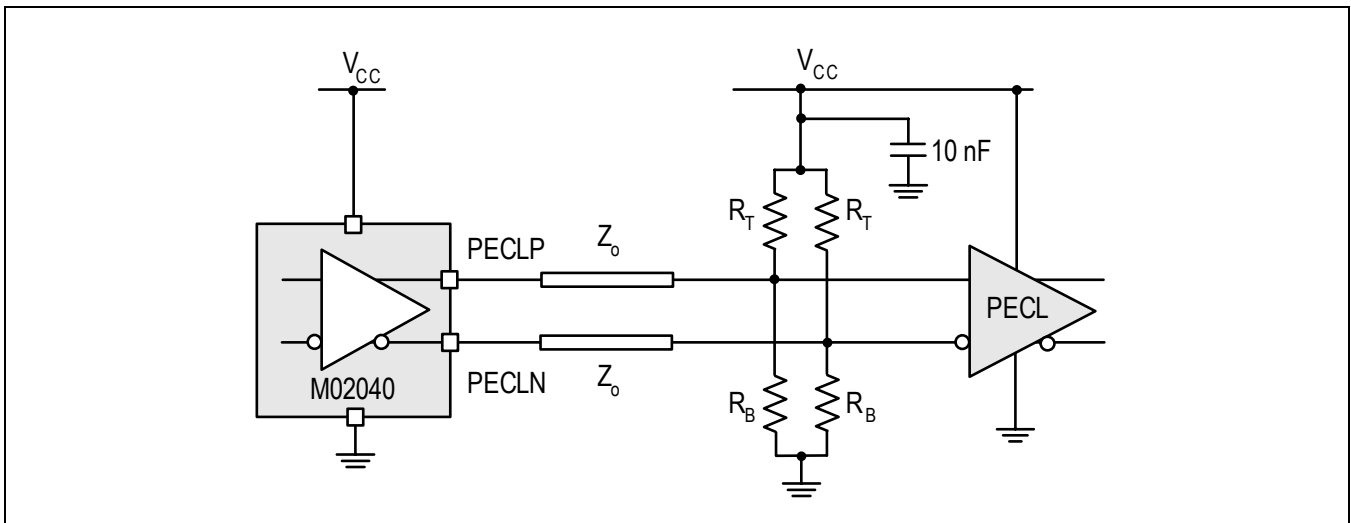
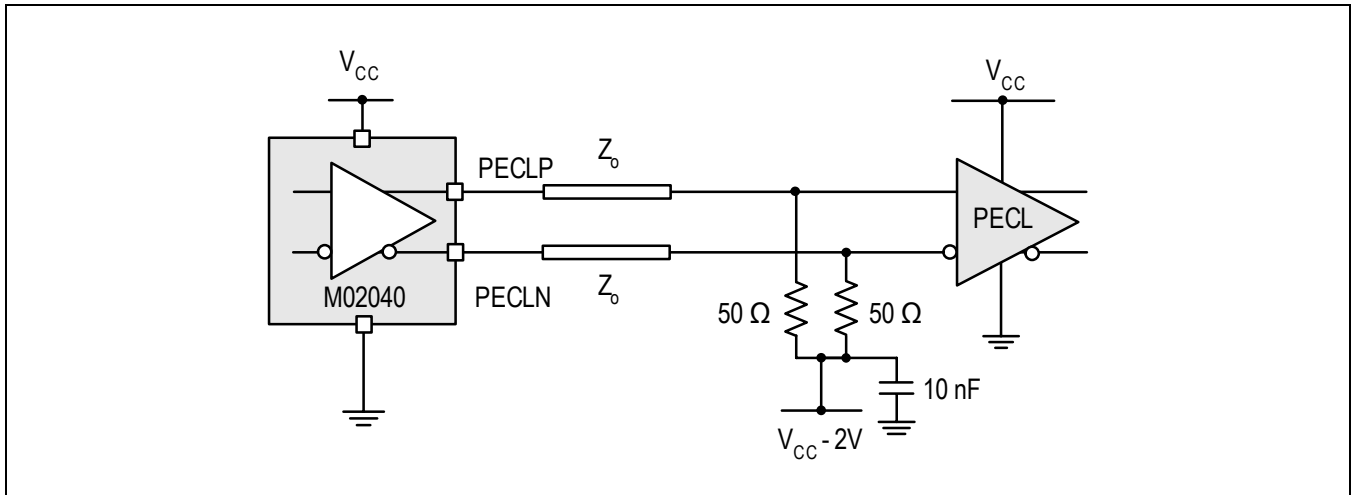

Figure 4-9. Alternative PECL Termination



4.1.8 Using JAM

As shown in the typical applications circuit (Figure 1-2), the LOS output pin can optionally be connected to the Jam input pin. When LOS asserts the Jam function sets the data outputs to a fixed “one” state (PECLP is held high and PECLN is held low). This is normally used to allow data to propagate only when the signal is above the users' bit error rate (BER) requirement. It prevents the outputs from toggling due to noise when no signal is present.

From the LOS assert and deassert figures above (Figure 4-2 - Figure 4-4), when an input signal is below the LOS assert threshold, LOS asserts (LOS high) causing Jam to assert. When Jam asserts, the data outputs and the internal servo loop of the M02040-15 are disabled. If the input signal reaches or exceeds the LOS deassert threshold, LOS deasserts (LOS low) causing Jam to deassert, and hence enables the data outputs and the internal servo loop. If, however, the input signal is slowly increasing to a level that does not exceed the LOS deassert threshold (operating in the hysteresis region), the internal servo loop may not be fully established and this may cause partial enabling of the data outputs. To avoid this the input signal needs to fully reach or exceed the LOS deassert level to fully enable the data outputs.



5.0 Package Specification

Figure 5-1. Package Information

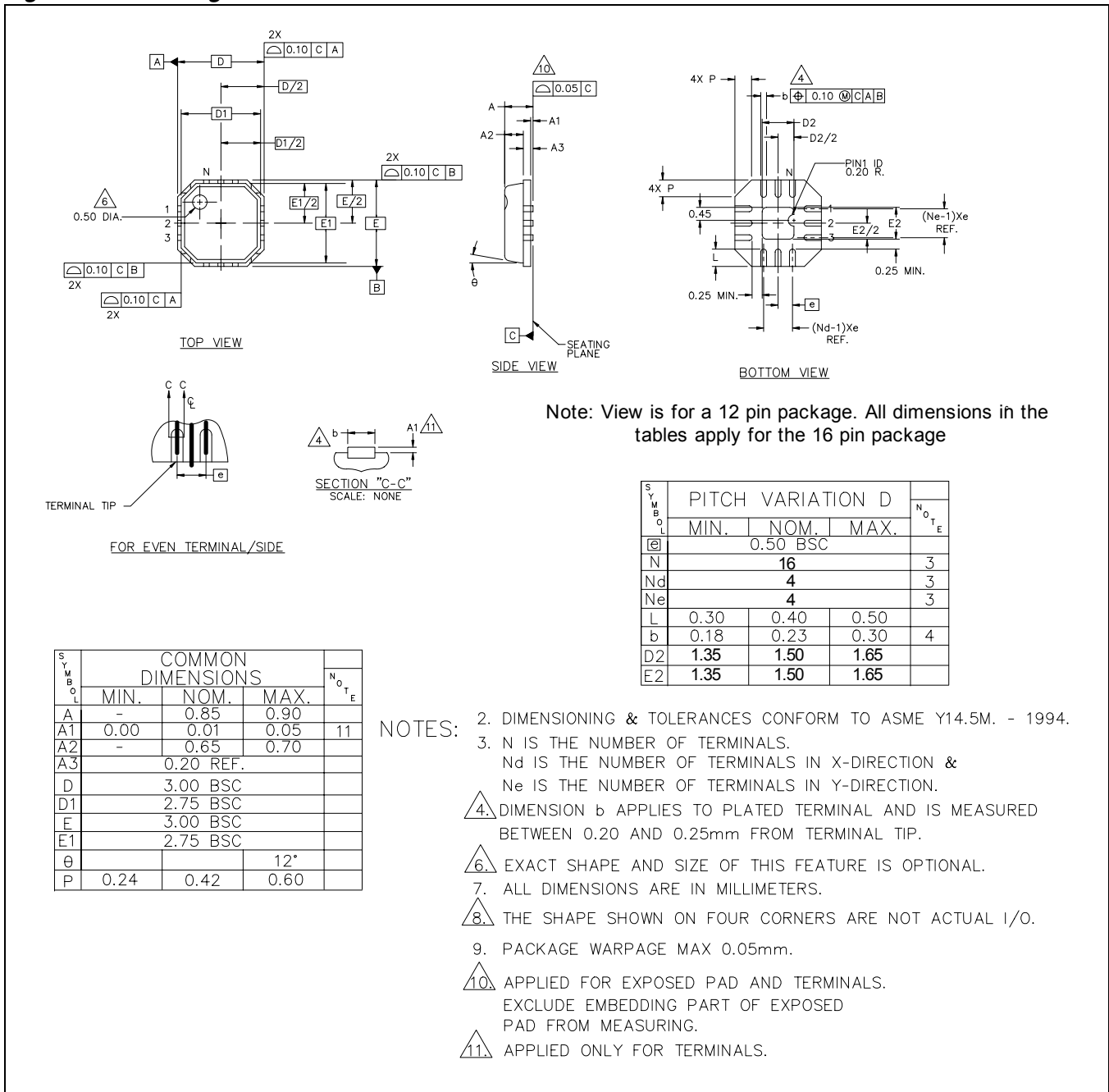

© 12/1/05, Mindspeed Technologies™, Inc. All rights reserved.

Information in this document is provided in connection with Mindspeed Technologies™ ("Mindspeed™") products. These materials are provided by Mindspeed as a service to its customers and may be used for informational purposes only. Except as provided in Mindspeed's Terms and Conditions of Sale for such products or in any separate agreement related to this document, Mindspeed assumes no liability whatsoever. Mindspeed assumes no responsibility for errors or omissions in these materials. Mindspeed may make changes to specifications and product descriptions at any time, without notice. Mindspeed makes no commitment to update the information and shall have no responsibility whatsoever for conflicts or incompatibilities arising from future changes to its specifications and product descriptions. No license, express or implied, by estoppel or otherwise, to any intellectual property rights is granted by this document.

THESE MATERIALS ARE PROVIDED "AS IS" WITHOUT WARRANTY OF ANY KIND, EITHER EXPRESS OR IMPLIED, RELATING TO SALE AND/OR USE OF MINDSPEED PRODUCTS INCLUDING LIABILITY OR WARRANTIES RELATING TO FITNESS FOR A PARTICULAR PURPOSE, CONSEQUENTIAL OR INCIDENTAL DAMAGES, MERCHANTABILITY, OR INFRINGEMENT OF ANY PATENT, COPYRIGHT OR OTHER INTELLECTUAL PROPERTY RIGHT. MINDSPEED FURTHER DOES NOT WARRANT THE ACCURACY OR COMPLETENESS OF THE INFORMATION, TEXT, GRAPHICS OR OTHER ITEMS CONTAINED WITHIN THESE MATERIALS. MINDSPEED SHALL NOT BE LIABLE FOR ANY SPECIAL, INDIRECT, INCIDENTAL, OR CONSEQUENTIAL DAMAGES, INCLUDING WITHOUT LIMITATION, LOST REVENUES OR LOST PROFITS, WHICH MAY RESULT FROM THE USE OF THESE MATERIALS.

Mindspeed products are not intended for use in medical, lifesaving or life sustaining applications. Mindspeed customers using or selling Mindspeed products for use in such applications do so at their own risk and agree to fully indemnify Mindspeed for any damages resulting from such improper use or sale.

www.mindspeed.com

General Information:
U.S. and Canada: (800) 854-8099
International: (949) 579-3000
Headquarters - Newport Beach
4000 MacArthur Blvd., East Tower
Newport Beach, CA. 92660