

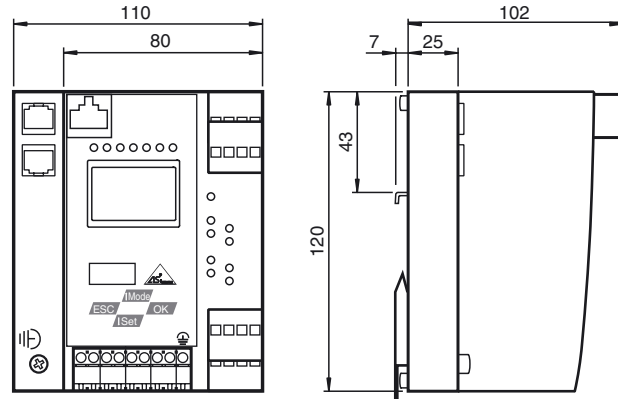

Dimensions

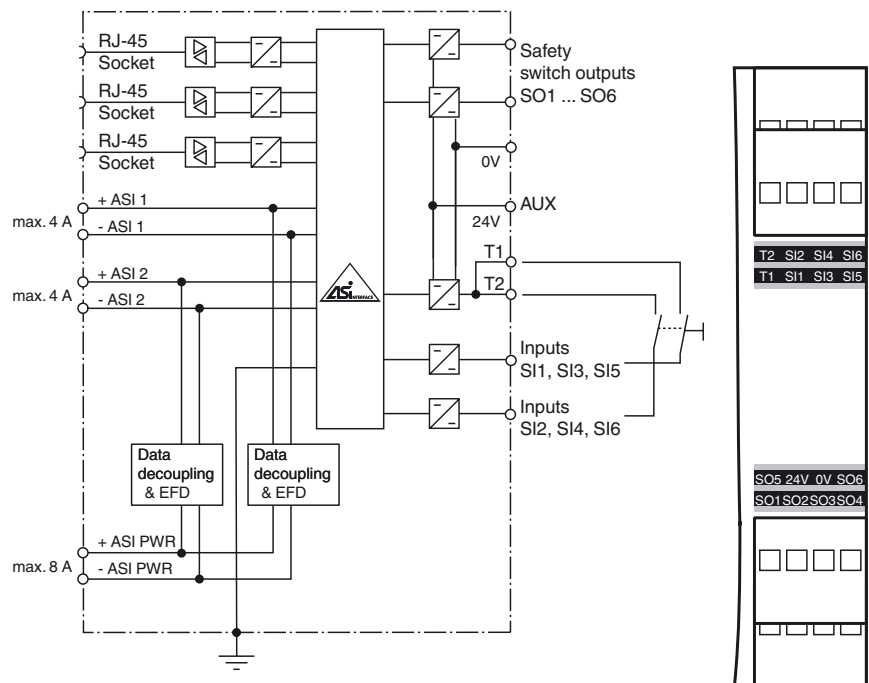

Electrical connection



Model number

VBG-EC-K30-DMD-S32-EV

EtherCat gateway with integrated safety monitor, double master for 2 AS-Interface networks, power supply input with decoupling coils

Features

- Gateway and safety monitor in one housing
- Connection to EtherCAT
- SafeLink
- Certified up to SIL 3 according to IEC 61508 and EN 62061 and up to PL_e according to EN 13849
- 2 AS-Interface networks
- Six safe electronic outputs
- Integrated data decoupling
- Duplicate addressing detection
- Earth fault detection
- AS-Interface noise detection
- Ethernet diagnostic interface

Indicating / Operating means

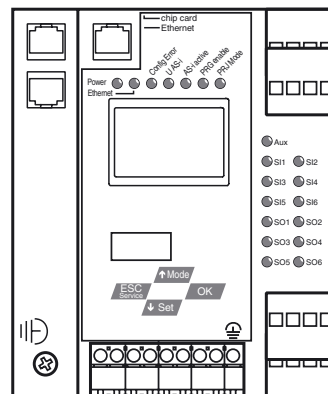

Release date: 2019-11-26 15:12 Date of issue: 2019-11-26 281885_eng.xml

Technical data**General specifications**

AS-Interface specification	V3.0
PLC-Functionality	activateable
Duplicate address detection	from AS-Interface slaves
Earth fault detection	EFD integrated
EMC monitoring	integrated
Diagnostics function	Extended function via display
Data decoupling	integrated
Switch-on delay	< 10 s
Response delay	< 40 ms
UL File Number	E223772 only from low voltage, limited energy source (SELV or PELV) or listed Class 2 source

Functional safety related parameters

Safety Integrity Level (SIL)	SIL 3
Performance level (PL)	PL e
MTTF _d	100 a
B _{10d}	2.5 E+5

Indicators/operating means

Display	Illuminated graphical LC display for addressing and error messages
LED ETHERNET	EtherCAT active; LED green
LED AS-i ACTIVE	AS-Interface operation normal; LED green
LED CONFIG ERR	configuration error; LED red
LED PRG ENABLE	autom. programming; LED green
LED POWER	voltage ON; LED green
LED PRJ MODE	projecting mode active; LED yellow
LED U AS-i	AS-Interface voltage; LED green
LED AUX	ext. auxiliary voltage U _{AUX} ; LED green
LED IN	6 x LED green
LED OUT	Output circuit closed; 6 x green LEDs
Button	4
Switch SET	Selection and setting of a slave address
OK button	Mode selection traditional-graphical/confirmation
Button MODE	Mode selection PRJ-operation/save configuration/cursor
ESC button	Mode selection traditional-graphical/cancel

Electrical specifications

Insulation voltage	U _i	≥ 500 V
Rated operating voltage	U _e	26.5 ... 31.6 V from AS-Interface; 24 V _{DC}
Rated operating current	I _e	approx. 300 mA PELV

Interface 1

Interface type	RJ-45
Physical	2 x RJ-45
Protocol	EtherCAT acc. to IEEE 802.3
Transfer rate	10 MBit/s / 100 MBit/s, Automatic baud rate detection

Interface 2

Interface type	RJ-45 Ethernet Diagnostic Interface
Transfer rate	10 MBit/s

Interface 3

Interface type	Chip card slot
----------------	----------------

Input

Number/Type	6 inputs Safety: 3 x 2 channels Or 6 standard inputs
-------------	------------------------------------------------------------

Output

Safety output	6 semiconductor outputs Output circuits: 6 PNP transistor outputs Max. contact load: 1.2 A _{DC-13} at 30 V _{DC} , Σ = 7.2 A in total (see derating)
---------------	--------------------------------------------------------------------------------------------------------------------------------------------------------------------------------

Connection

Ethernet	RJ-45
AS-Interface	spring terminals, removable

Directive conformity

Electromagnetic compatibility	
Directive 2014/30/EU	EN 62026-2:2013 EN 61000-6-2/AC:2005, EN 61000-6-4:2007+A1:2011
Machinery Directive	
Directive 2006/42/EC	EN 61508:2010 EN ISO 13849-1/AC:2009 EN 62061:2005+A1:2013

Standard conformity

Degree of protection	EN 60529:2000
Emitted interference	EN 61000-6-4:2007/A1:2011
AS-Interface	EN 62026-2:2013
Noise immunity	EN 61000-6-2/AC:2005
Shock resistance	EN 61131-2:2004

Function

The VBG-EC-K30-DMD-S32-EV is a EtherCAT gateway with a safety monitor and a double master according to AS-Interface specification 3.0.

The device is a gateway with full functionality combined with a safety monitor. The gateway connects an AS-Interface system to a higher-level EtherCAT protocol. It acts as a master for the AS-Interface segment and as a slave for Ethernet / Modbus. During cyclic data exchange, the digital data of an AS-Interface segment is transferred. Analog values as well as the complete command set of the new AS-Interface specification are transferred via EtherCAT using a command interface.

The gateway has 6 inputs and outputs. The 6 inputs are used for enhanced device monitoring EDM or start inputs. The 6 outputs switch channel 1 and 2 as semiconductor outputs. The K30 design is particularly suitable for use in control cabinets.

Configuration of the device can be performed using switches. Seven LED located on the front panel indicate the current status of the AS-Interface segment. One LED shows the power supply via AUX. A further eight LEDs indicate the status of the inputs and outputs.

With the graphical display, the commissioning of the AS-Interface circuits and testing of the connected peripherals can take place completely separately from the commissioning of the higher-level network and the programming. With the 4 switches, all functions can be controlled and visualized on the display.

An RJ-45 Ethernet port provides a way of exporting data relating to the gateway, network and operation directly from the gateway for extended local diagnosis purposes.

Via the RJ-45 Ethernet diagnostic interface, up to 31 devices can establish a secure cross-communication.

The integrated data decoupling allows to operate 2 AS-Interface circuits with just a standard power supply.

The device has a card slot for a memory card for the storage of configuration data.

The device can be operated with a 24 V power supply according to PELV.

Accessories**VAZ-SW-SIMON+**

Software for configuration of K30 Master Monitors/K31 and KE4 Safety Monitors

Functional safety	EN ISO 13849-1:2008/AC:2009, EN ISO 13849-2:2012 (up to PL e), EN 61508:2010 and EN 62061:2005+A1:2013 (up to SIL3)
Ambient conditions	
Ambient temperature	0 ... 55 °C (32 ... 131 °F)
Storage temperature	-25 ... 85 °C (-13 ... 185 °F)
Mechanical specifications	
Degree of protection	IP20
Material	
Housing	Stainless steel
Mass	800 g
Construction type	Low profile housing
Approvals and certificates	
UL approval	An isolated source with a secondary open circuit voltage of $\leq 30 V_{DC}$ with a 3 A maximum over current protection. Over current protection is not required when a Class 2 source is employed. UL mark does not provide UL certification for any functional safety rating or aspects of the device.

Notes

In an AS-Interface network only one device can be operated earth fault detection. If there are many devices in an AS-Interface network, this can lead to the earth fault monitoring response threshold becoming less sensitive.

Derating output current

