

Domiled

Synonymous with function and performance, the Domiled series is perfectly suited for a variety of cross-industrial applications due to its small package outline, durability and superior brightness.



Features:

- > High brightness surface mount LED.
- > Designed for sideways illumination.
- > 120° viewing angle.
- > Small package outline.
- > Qualified according to JEDEC moisture sensitivity Level 2.
- > Compatible to IR reflow soldering.
- > Environmental friendly; RoHS compliance.
- > Compliance to automotive standard; AEC-Q101.
- > Passed Corrosion Resistant Test. *Appx. 4.1*



Applications:

- > Automotive: interior applications, eg: switches, telematics, climate control system, dashboard, etc.
- > Consumer Appliances: LCD illumination as in PDAs, LCD TV.
- > Display: full color display video notice board.
- > Industry: white goods (eg: Oven, microwave, etc.).

Optical Characteristics at Tj=25°C

Part Ordering Number	Color	Viewing Angle°	Luminous Intensity @ 20mA IV (mcd) <i>Appx. 1.1</i>		
			Min.	Typ.	Max.
DSF-LSG-WX1-4O9X	Warm White	120	1125.0	1800.0	2240.0
DSF-LSG-W2X-4J8N	Warm White	120	1400.0	2240.0	2850.0

Electrical Characteristics at Tj=25°C

Part Number	Vf @ If = 20mA <i>Appx. 3.1</i>			Vr @ Ir = 10uA
	Min. (V)	Typ. (V)	Max. (V)	Min. (V)
DSF-LSG	2.8	3.2	3.6	5.0

Absolute Maximum Ratings

	Maximum Value	Unit
DC forward current	20	mA
Peak pulse current; (tp ≤ 10μs, Duty cycle = 0.005)	100	mA
Reverse voltage; Ir (max) = 10uA	5	V
ESD threshold (HBM)	2000	V
LED junction temperature	125	°C
Operating temperature	-40 ... +100	°C
Storage temperature	-40 ... +100	°C
Power dissipation (at room temperature)	80	mW
Thermal resistance		
- Junction / ambient, R _{th JA}	460	K/W
- Junction / solder point, R _{th JS}	240	K/W
(Mounting on FR4 PCB, pad size ≥ 5 mm ² per pad)		

Color Bin - Warm White *Appx. 2.1*

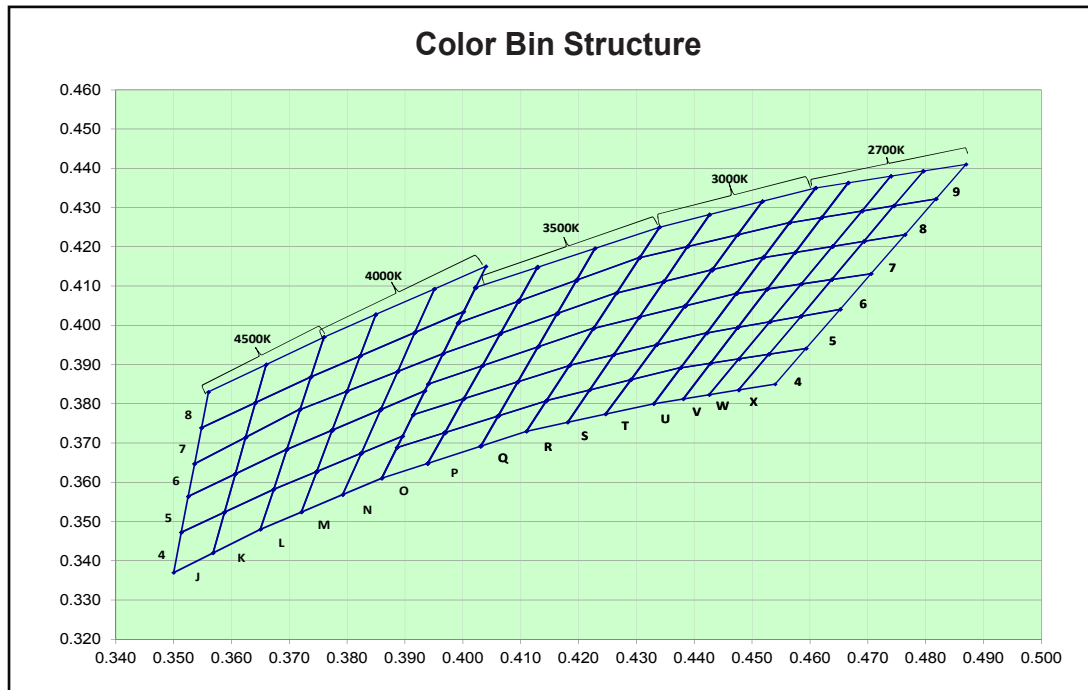

Bin		1	2	3	4
4U	Cx	0.4377	0.4428	0.4381	0.4330
	Cy	0.3891	0.3903	0.3812	0.3800
5U	Cx	0.4422	0.4476	0.4428	0.4377
	Cy	0.3981	0.3995	0.3903	0.3891
6U	Cx	0.4473	0.4526	0.4476	0.4422
	Cy	0.4081	0.4092	0.3995	0.3981
7U	Cx	0.4520	0.4574	0.4526	0.4473
	Cy	0.4172	0.4185	0.4092	0.4081
8U	Cx	0.4565	0.4621	0.4574	0.4520
	Cy	0.4261	0.4275	0.4185	0.4172
9U	Cx	0.4610	0.4666	0.4621	0.4565
	Cy	0.4350	0.4363	0.4275	0.4261
4V	Cx	0.4428	0.4478	0.4426	0.4381
	Cy	0.3903	0.3914	0.3823	0.3812
5V	Cx	0.4476	0.4531	0.4478	0.4428
	Cy	0.3995	0.4009	0.3914	0.3903
6V	Cx	0.4526	0.4585	0.4531	0.4476
	Cy	0.4092	0.4105	0.4009	0.3995
7V	Cx	0.4574	0.4639	0.4585	0.4526
	Cy	0.4185	0.4201	0.4105	0.4092
8V	Cx	0.4621	0.4690	0.4639	0.4574
	Cy	0.4275	0.4291	0.4201	0.4185
9V	Cx	0.4666	0.4740	0.4690	0.4621
	Cy	0.4363	0.4380	0.4291	0.4275

Bin		1	2	3	4
4W	Cx	0.4478	0.4529	0.4477	0.4426
	Cy	0.3914	0.3926	0.3835	0.3823
5W	Cx	0.4531	0.4585	0.4529	0.4478
	Cy	0.4009	0.4023	0.3926	0.3914
6W	Cx	0.4585	0.4638	0.4585	0.4531
	Cy	0.4105	0.4117	0.4023	0.4009
7W	Cx	0.4639	0.4694	0.4638	0.4585
	Cy	0.4201	0.4214	0.4117	0.4105
8W	Cx	0.4690	0.4745	0.4694	0.4639
	Cy	0.4291	0.4305	0.4214	0.4201
9W	Cx	0.4740	0.4796	0.4745	0.4690
	Cy	0.4380	0.4393	0.4305	0.4291
4X	Cx	0.4529	0.4593	0.4540	0.4477
	Cy	0.3926	0.3941	0.3850	0.3835
5X	Cx	0.4585	0.4652	0.4593	0.4529
	Cy	0.4023	0.4041	0.3941	0.3926
6X	Cx	0.4638	0.4706	0.4652	0.4585
	Cy	0.4117	0.4131	0.4041	0.4023
7X	Cx	0.4694	0.4765	0.4706	0.4638
	Cy	0.4214	0.4231	0.4131	0.4117
8X	Cx	0.4745	0.4818	0.4765	0.4694
	Cy	0.4305	0.4322	0.4231	0.4214
9X	Cx	0.4796	0.4870	0.4818	0.4745
	Cy	0.4393	0.4410	0.4322	0.4305
4R	Cx	0.4145	0.4219	0.4181	0.4110
	Cy	0.3808	0.3835	0.3753	0.3730
5R	Cx	0.4184	0.4261	0.4219	0.4145
	Cy	0.3898	0.3925	0.3835	0.3808
6R	Cx	0.4226	0.4305	0.4261	0.4184
	Cy	0.3992	0.4021	0.3925	0.3898
7R	Cx	0.4266	0.4347	0.4305	0.4226
	Cy	0.4082	0.4111	0.4021	0.3992
8R	Cx	0.4305	0.4389	0.4347	0.4266
	Cy	0.4172	0.4201	0.4111	0.4082
9R	Cx	0.4340	0.4426	0.4389	0.4305
	Cy	0.4250	0.4282	0.4201	0.4172
4S	Cx	0.4219	0.4291	0.4247	0.4181
	Cy	0.3835	0.3861	0.3774	0.3753
5S	Cx	0.4261	0.4335	0.4291	0.4219
	Cy	0.3925	0.3951	0.3861	0.3835
6S	Cx	0.4305	0.4385	0.4335	0.4261
	Cy	0.4021	0.4049	0.3951	0.3925
7S	Cx	0.4347	0.4431	0.4385	0.4305
	Cy	0.4111	0.4141	0.4049	0.4021
8S	Cx	0.4389	0.4475	0.4431	0.4347
	Cy	0.4201	0.4231	0.4141	0.4111
9S	Cx	0.4426	0.4518	0.4475	0.4389
	Cy	0.4282	0.4316	0.4231	0.4201
4T	Cx	0.4291	0.4377	0.4330	0.4247
	Cy	0.3861	0.3893	0.3800	0.3774

Bin		1	2	3	4
5T	Cx	0.4335	0.4422	0.4377	0.4291
	Cy	0.3951	0.3981	0.3893	0.3861
6T	Cx	0.4385	0.4473	0.4422	0.4335
	Cy	0.4049	0.4081	0.3981	0.3951
7T	Cx	0.4431	0.4520	0.4473	0.4385
	Cy	0.4141	0.4174	0.4081	0.4049
8T	Cx	0.4475	0.4565	0.4520	0.4431
	Cy	0.4231	0.4262	0.4174	0.4141
9T	Cx	0.4518	0.4610	0.4565	0.4475
	Cy	0.4316	0.4350	0.4262	0.4231
4O	Cx	0.3886	0.3969	0.3939	0.3860
	Cy	0.3688	0.3726	0.3648	0.3610
5O	Cx	0.3914	0.4002	0.3969	0.3886
	Cy	0.3772	0.3813	0.3726	0.3688
6O	Cx	0.3940	0.4034	0.4002	0.3914
	Cy	0.3850	0.3897	0.3813	0.3772
7O	Cx	0.3966	0.4065	0.4034	0.3940
	Cy	0.3928	0.3979	0.3897	0.3850
8O	Cx	0.3992	0.4096	0.4065	0.3966
	Cy	0.4006	0.4061	0.3979	0.3928
9O	Cx	0.4022	0.4129	0.4096	0.3992
	Cy	0.4096	0.4148	0.4061	0.4006
4P	Cx	0.3969	0.4061	0.4031	0.3939
	Cy	0.3726	0.3769	0.3692	0.3648
5P	Cx	0.4002	0.4095	0.4061	0.3969
	Cy	0.3813	0.3856	0.3769	0.3726
6P	Cx	0.4034	0.4130	0.4095	0.4002
	Cy	0.3897	0.3945	0.3856	0.3813
7P	Cx	0.4065	0.4163	0.4130	0.4034
	Cy	0.3979	0.4030	0.3945	0.3897
8P	Cx	0.4096	0.4197	0.4163	0.4065
	Cy	0.4061	0.4115	0.4030	0.3979
9P	Cx	0.4129	0.4228	0.4197	0.4096
	Cy	0.4148	0.4196	0.4115	0.4061
4Q	Cx	0.4061	0.4144	0.4110	0.4031
	Cy	0.3769	0.3807	0.3730	0.3692
5Q	Cx	0.4095	0.4184	0.4144	0.4061
	Cy	0.3856	0.3897	0.3807	0.3769
6Q	Cx	0.4130	0.4226	0.4184	0.4095
	Cy	0.3945	0.3993	0.3897	0.3856
7Q	Cx	0.4163	0.4266	0.4226	0.4130
	Cy	0.4030	0.4083	0.3993	0.3945
8Q	Cx	0.4197	0.4306	0.4266	0.4163
	Cy	0.4115	0.4173	0.4083	0.4030
9Q	Cx	0.4228	0.4340	0.4306	0.4197
	Cy	0.4196	0.4250	0.4173	0.4115
4L	Cx	0.3673	0.3747	0.3721	0.3650
	Cy	0.3582	0.3627	0.3524	0.3480
5L	Cx	0.3696	0.3774	0.3747	0.3673
	Cy	0.3684	0.3733	0.3627	0.3582

Bin		1	2	3	4
6L	Cx	0.3718	0.3799	0.3774	0.3696
	Cy	0.3785	0.3832	0.3733	0.3684
7L	Cx	0.3737	0.3822	0.3799	0.3718
	Cy	0.3868	0.3922	0.3832	0.3785
8L	Cx	0.3760	0.3849	0.3822	0.3737
	Cy	0.3970	0.4027	0.3922	0.3868
4M	Cx	0.3747	0.3824	0.3792	0.3721
	Cy	0.3627	0.3674	0.3568	0.3524
5M	Cx	0.3774	0.3858	0.3824	0.3747
	Cy	0.3733	0.3785	0.3674	0.3627
6M	Cx	0.3799	0.3887	0.3858	0.3774
	Cy	0.3832	0.3882	0.3785	0.3733
7M	Cx	0.3822	0.3917	0.3887	0.3799
	Cy	0.3922	0.3982	0.3882	0.3832
8M	Cx	0.3849	0.3951	0.3917	0.3822
	Cy	0.4027	0.4093	0.3982	0.3922
4N	Cx	0.3824	0.3896	0.3860	0.3792
	Cy	0.3674	0.3717	0.3610	0.3568
5N	Cx	0.3858	0.3934	0.3896	0.3824
	Cy	0.3785	0.3833	0.3717	0.3674
6N	Cx	0.3887	0.3966	0.3934	0.3858
	Cy	0.3882	0.3928	0.3833	0.3785
7N	Cx	0.3917	0.4002	0.3966	0.3887
	Cy	0.3982	0.4035	0.3928	0.3882
8N	Cx	0.3951	0.4040	0.4002	0.3917
	Cy	0.4093	0.4150	0.4035	0.3982
4J	Cx	0.3513	0.3588	0.3568	0.3500
	Cy	0.3472	0.3524	0.3420	0.3370
5J	Cx	0.3525	0.3607	0.3588	0.3513
	Cy	0.3564	0.3621	0.3524	0.3472
6J	Cx	0.3536	0.3624	0.3607	0.3525
	Cy	0.3647	0.3715	0.3621	0.3564
7J	Cx	0.3548	0.3641	0.3624	0.3536
	Cy	0.3739	0.3803	0.3715	0.3647
8J	Cx	0.3560	0.3660	0.3641	0.3548
	Cy	0.3830	0.3900	0.3803	0.3739
4K	Cx	0.3588	0.3673	0.3650	0.3568
	Cy	0.3524	0.3582	0.3480	0.3420
5K	Cx	0.3607	0.3696	0.3673	0.3588
	Cy	0.3621	0.3684	0.3582	0.3524
6K	Cx	0.3624	0.3719	0.3696	0.3607
	Cy	0.3715	0.3787	0.3684	0.3621
7K	Cx	0.3641	0.3737	0.3719	0.3624
	Cy	0.3803	0.3868	0.3787	0.3715
8K	Cx	0.3660	0.3760	0.3737	0.3641
	Cy	0.3900	0.3970	0.3868	0.3803

InGaN wavelength is very sensitive to drive current. Operating at lower current is not recommended and may yield unpredictable performance current pulsing should be used for dimming purposed.

Luminous Intensity Group at Tj=25°C

Brightness Group	Luminous Intensity <small>Appx. 1.1</small> IV (mcd)
W1	1125.0 ... 1400.0
W2	1400.0 ... 1800.0
X1	1800.0 ... 2240.0
X2	2240.0 ... 2850.0

Relative Luminous Intensity Vs Forward Current

$I_v/I_v(20mA) = f(I_F); T_j = 25^\circ C$

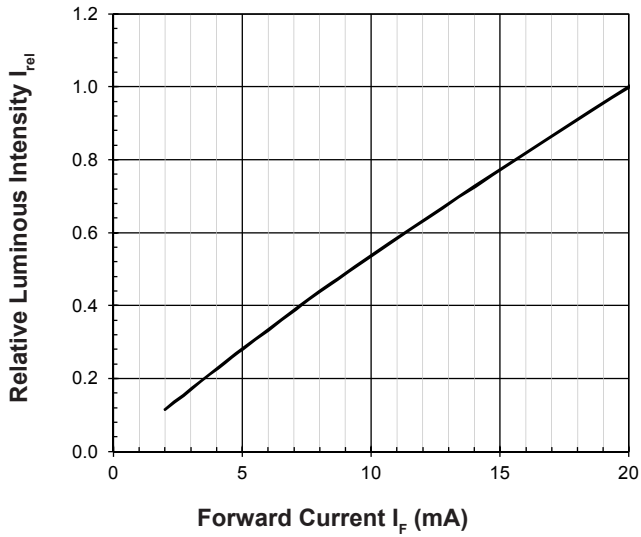

Forward Current Vs Forward Voltage

$I_F = f(V_F); T_j = 25^\circ C$

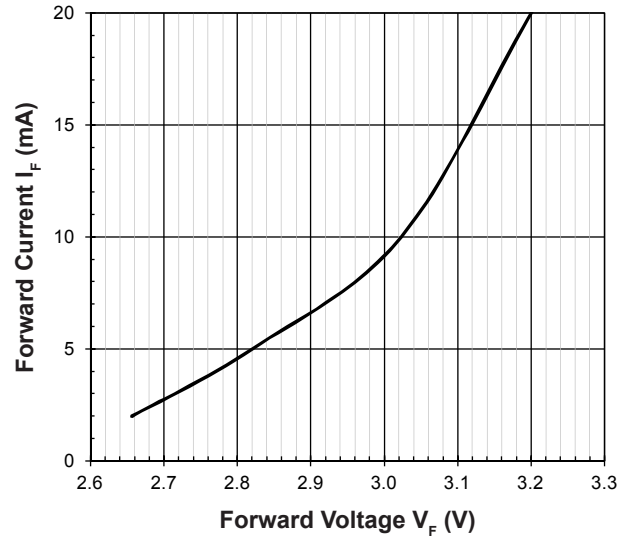

Maximum Current Vs Temperature

$I_F = f(T)$

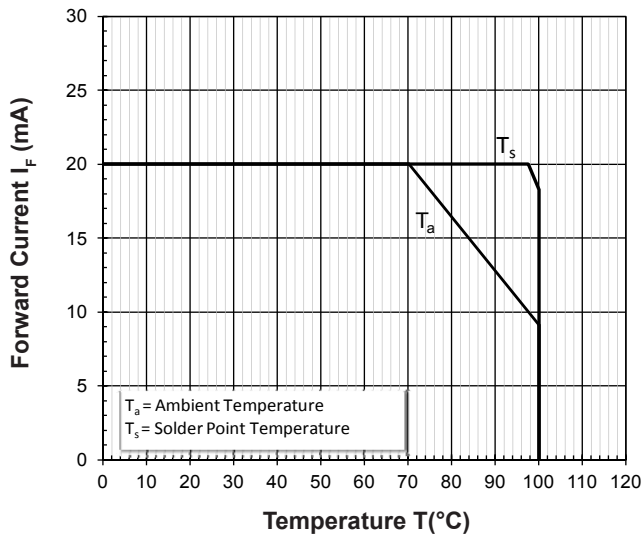

Relative Spectral Emission

$I_{rel} = f(\lambda); T_j = 25^\circ C; I_F = 20mA$

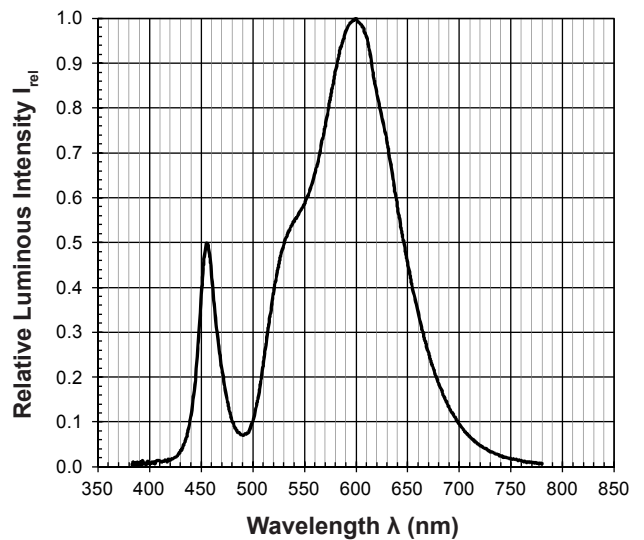

Chromaticity Coordinate Shift Vs Forward Current

$\Delta Cx, \Delta Cy = f(I_F); T_j = 25^\circ C$

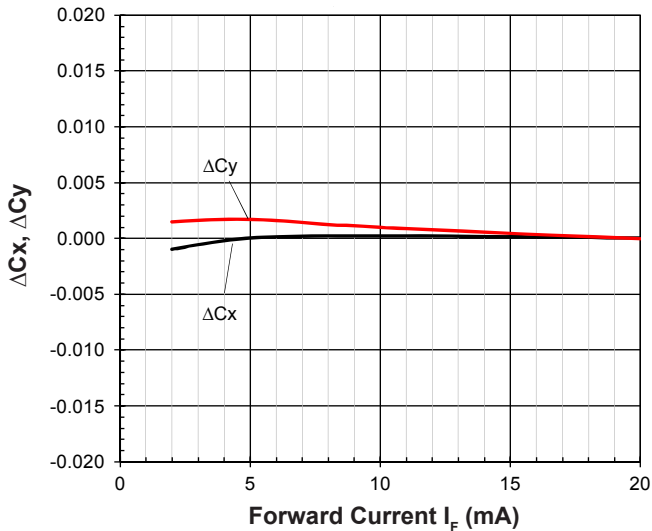

Allowable Forward Current Vs Duty Ratio

$(T_j = 25^\circ C; t_p \le 10\mu s)$



Radiation Pattern

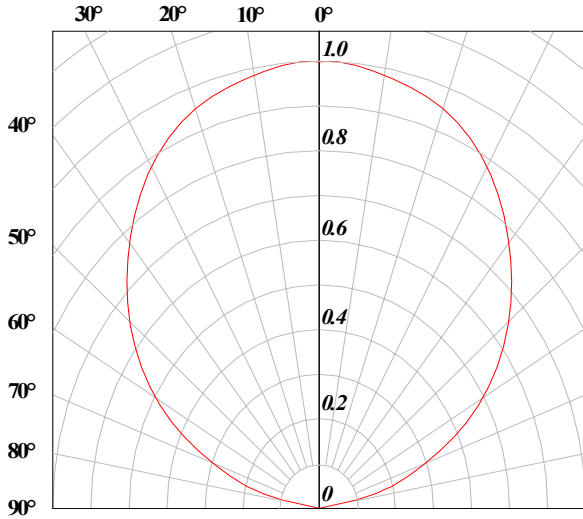

Relative Forward Voltage Vs Junction Temperature

$$\Delta V_F = V_F - V_F(25^\circ\text{C}) = f(T_j); I_F = 20\text{mA}$$

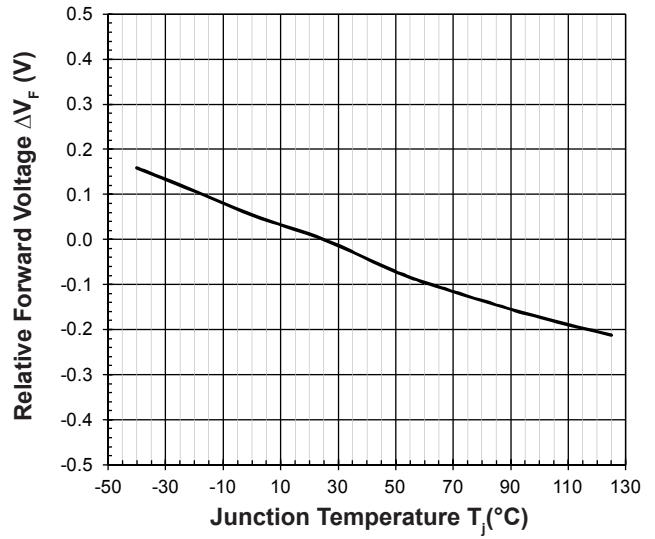

Relative Luminous Intensity Vs Junction Temperature

$$I_V/I_V(25^\circ\text{C}) = f(T_j); I_F = 20\text{mA}$$

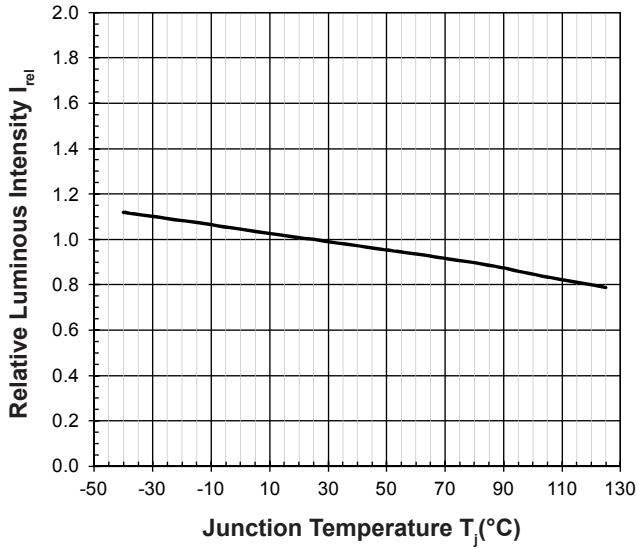

Chromaticity Coordinate Shift Vs Junction Temperature

$$\Delta Cx, \Delta Cy = f(T_j); I_F = 20\text{mA}$$

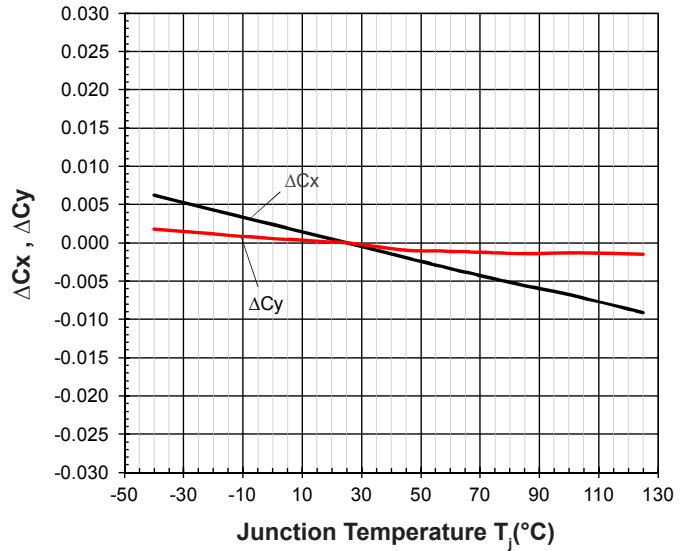

Right Angle DomiLED • InGaN Warm White : DSF-LSG Package Outlines

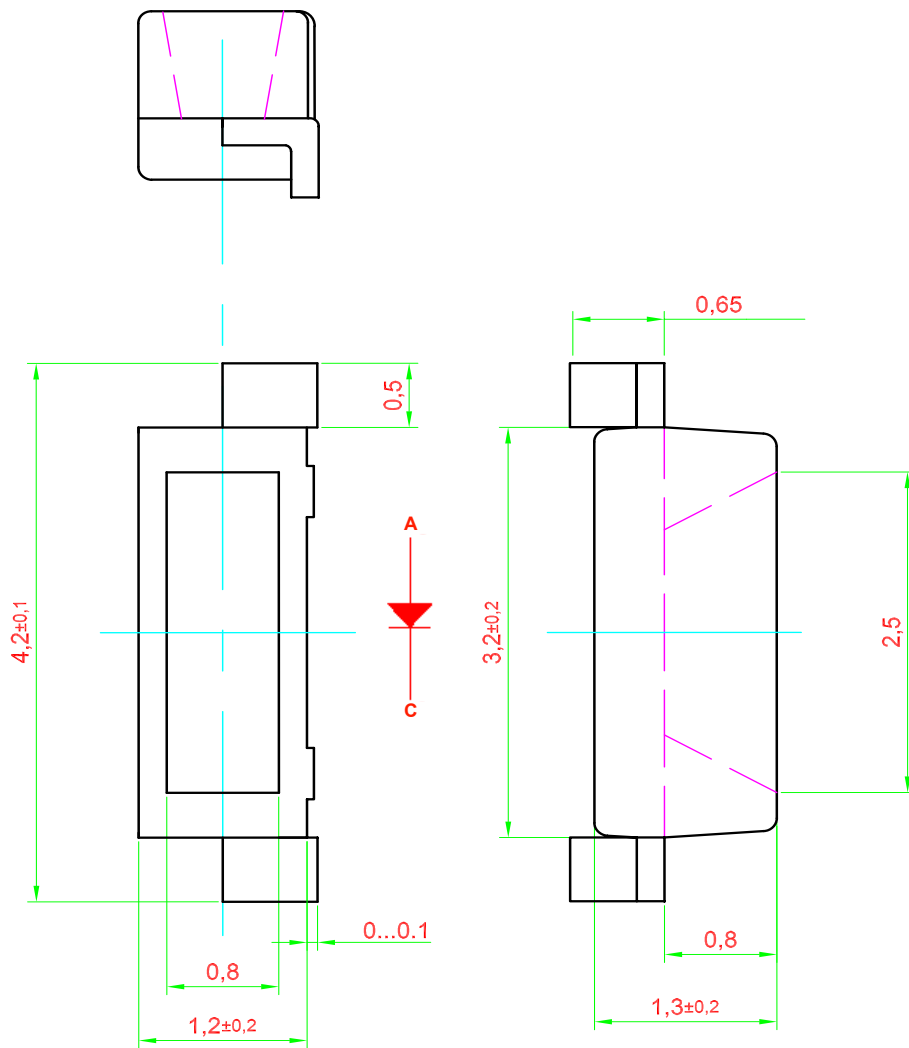

General tolerance ±0.1mm

Note : Primary thermal path is through Cathode lead of LED package.

Material

	Material
Lead-frame	Cu Alloy With Ag Plating
Package	High Temperature Resistant Plastic, PPA
Encapsulant	Silicone Resin
Soldering Leads	Sn-Sn Plating

Recommended Solder Pad

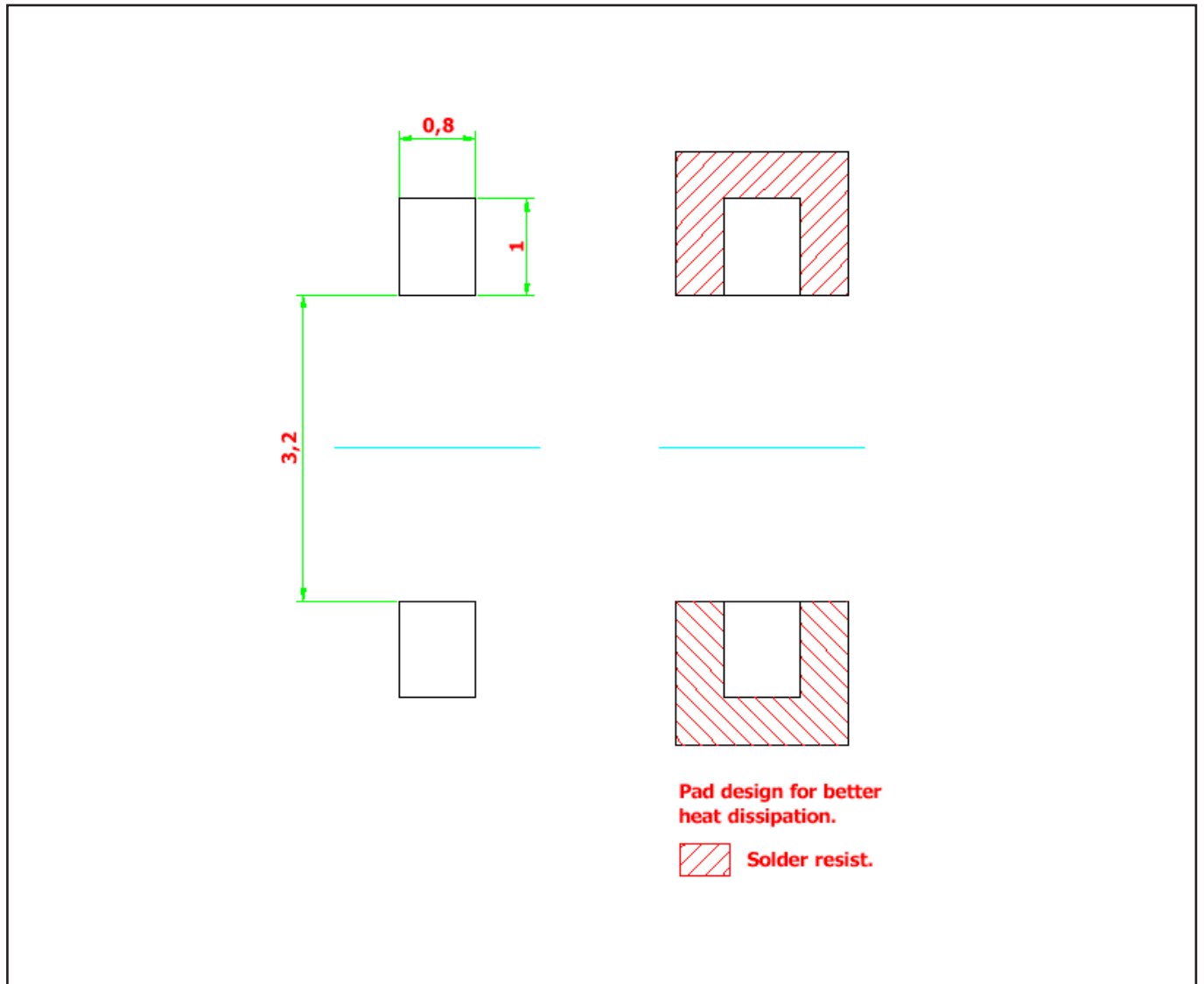

Taping and orientation

- Reels come in quantity of 2500 units.
- Reel diameter is 180 mm.

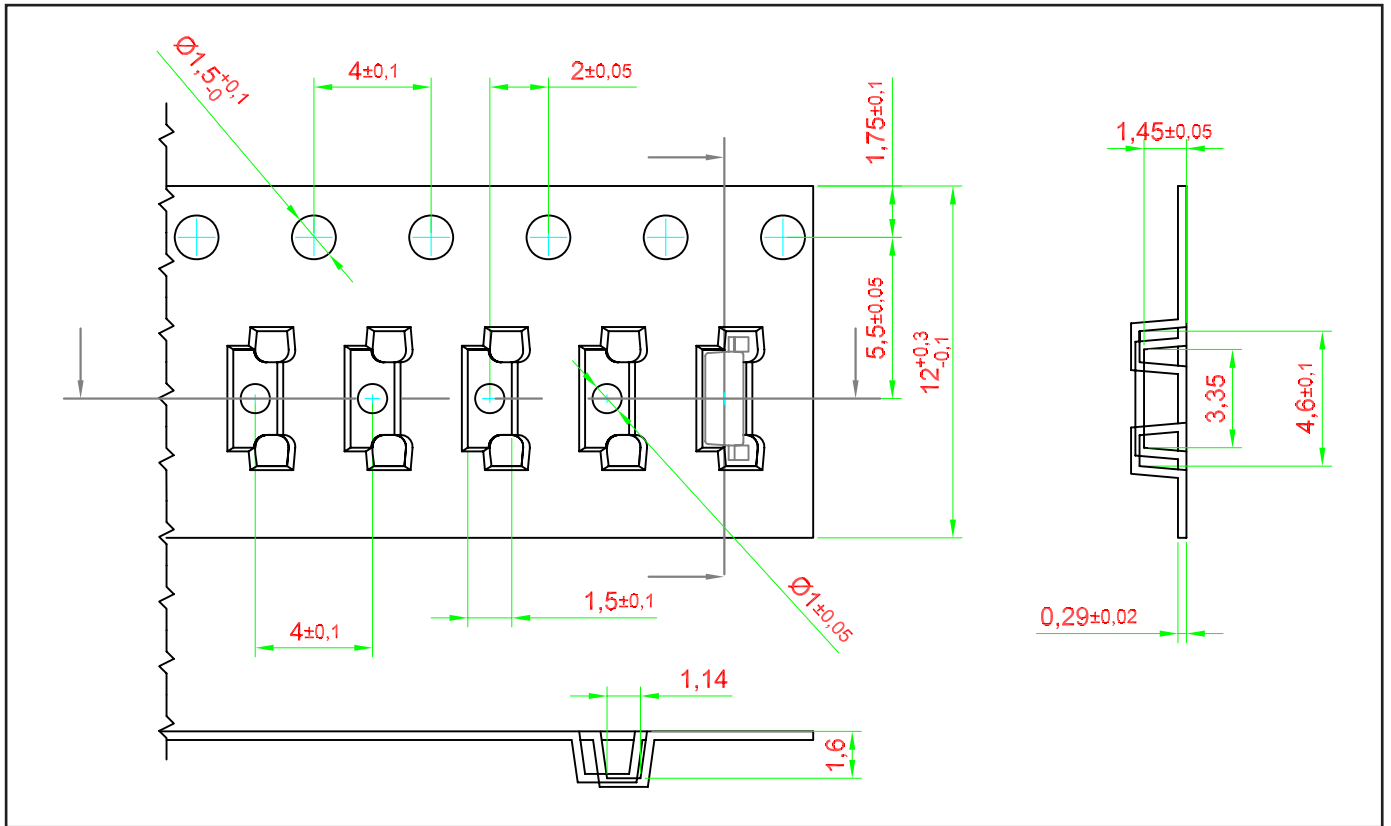

Packaging Specification

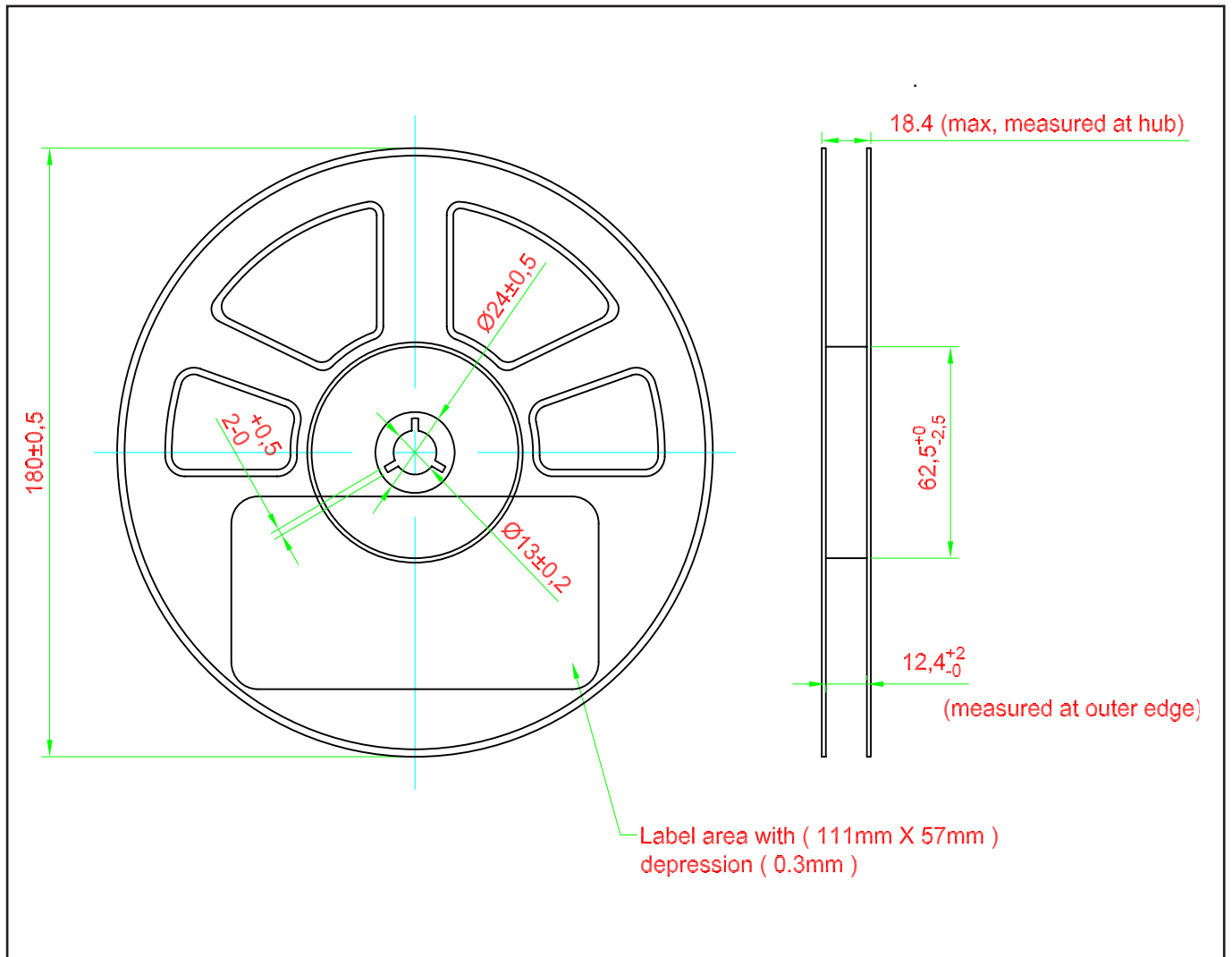

Packaging Specification

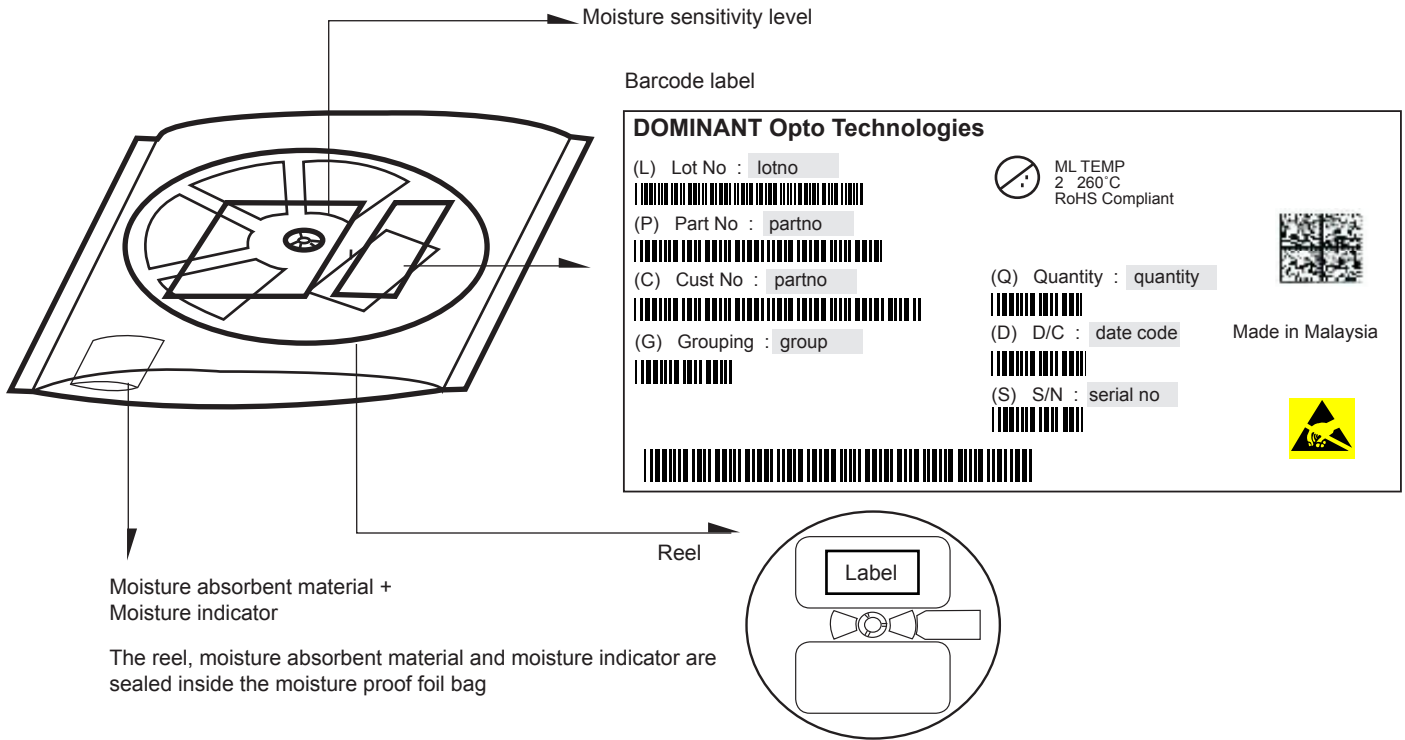

Average 1pc Right Angle DomiLED	1 completed bag (2500pcs)
Weight (gram)	0.010
	240 ± 10

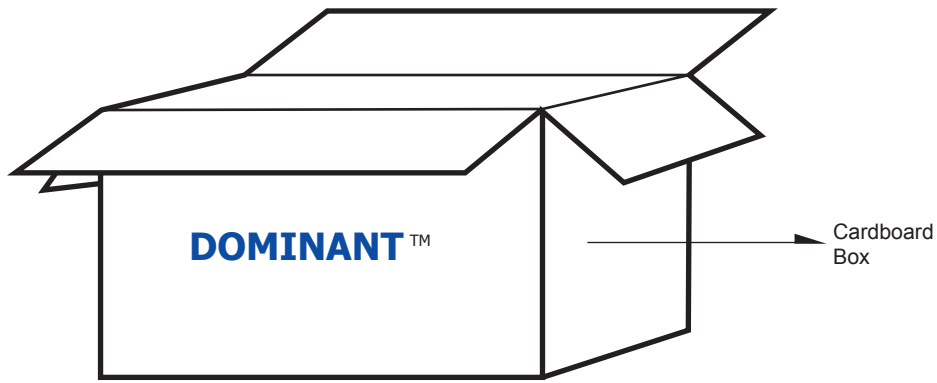

For Right Angle DomiLED™

Cardboard Box Size	Dimensions (mm)	Empty Box Weight (kg)	Reel / Box
Super Small	325 x 225 x 190	0.38	7 reels MAX
Small	325 x 225 x 280	0.54	11 reels MAX
Medium	570 x 440 x 230	1.46	48 reels MAX
Large	570 x 440 x 460	1.92	96 reels MAX

Recommended Pb-free Soldering Profile

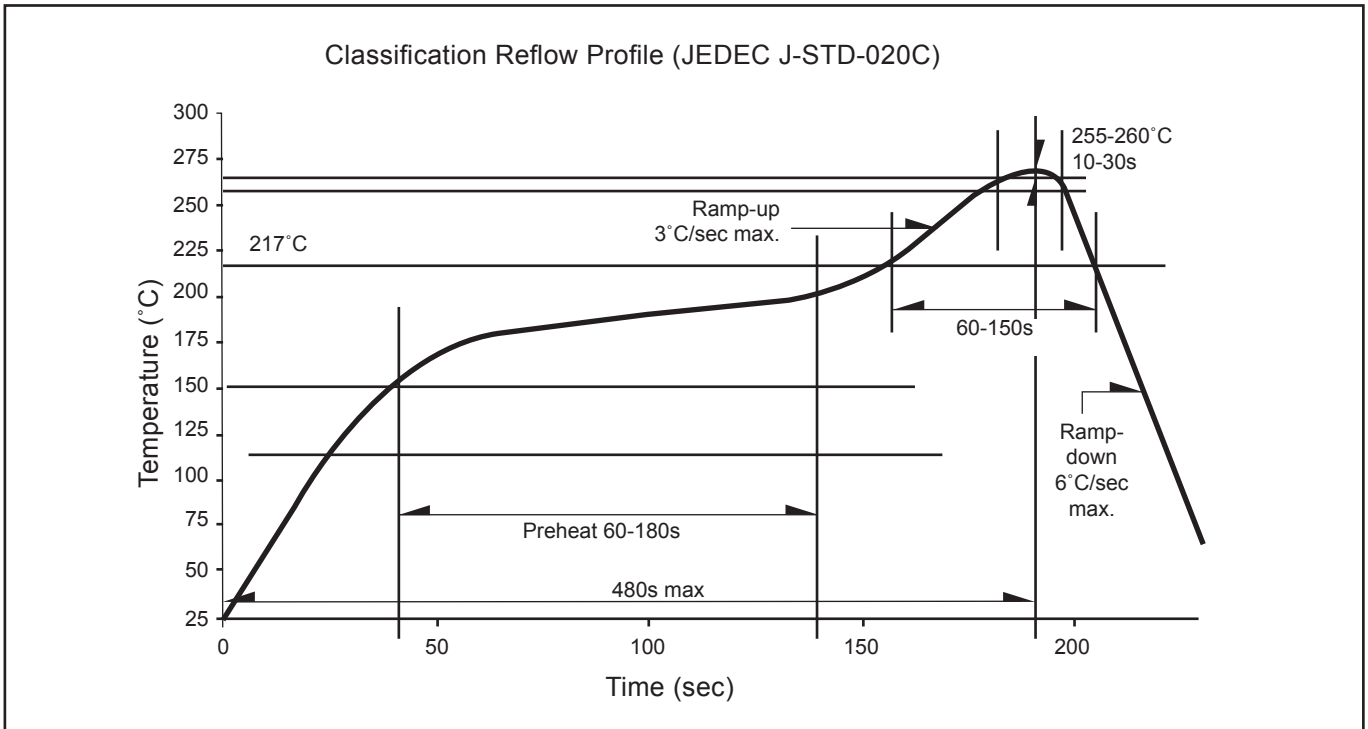

Appendix

1) **Brightness:**

- 1.1 Luminous intensity is measured with an internal reproducibility of $\pm 8 \%$ and an expanded uncertainty of $\pm 11 \%$ (according to GUM with a coverage factor of $k=3$).
- 1.2 Luminous flux is measured with an internal reproducibility of $\pm 8 \%$ and an expanded uncertainty of $\pm 11 \%$ (according to GUM with a coverage factor of $k=3$).

2) **Color:**

- 2.1 Chromaticity coordinate groups are measured with an internal reproducibility of ± 0.005 and an expanded uncertainty of ± 0.01 (accordingly to GUM with a coverage factor of $k=3$).
- 2.2 DOMINANT wavelength is measured with an internal reproducibility of $\pm 0.5\text{nm}$ and an expanded uncertainty of $\pm 1\text{nm}$ (accordingly to GUM with a coverage factor of $k=3$).

3) **Voltage:**

- 3.1 Forward Voltage, V_f is measured with an internal reproducibility of $\pm 0.05\text{V}$ and an expanded uncertainty of $\pm 0.1\text{V}$ (accordingly to GUM with a coverage factor of $k=3$).

4) **Corrosion Robustness:**

- 4.1 Test conditions: $40 \text{ }^\circ\text{C} / 90 \text{ \% rh} / 15 \text{ ppm H}_2\text{S} / 336 \text{ h}$.
= Stricter than IEC 60068-2-43 (H_2S) [$25 \text{ }^\circ\text{C} / 75\% \text{ rh} / 10 \text{ ppm H}_2\text{S} / 21 \text{ days}$].

Revision History

Page	Subjects	Date of Modification
-	Initial Release	17 Jun 2013
10	Error on Packaging Specification	02 May 2014
1, 7, 9, 11	Add Features Add Notes in Package Outline Update Carrier Tape Update Package Specification	10 Mar 2015
1, 6, 7, 8, 14	Update Features Update Graph Update Package Outline Add Appendix	28 Sep 2016
1, 2, 3, 4, 5, 6	Update Product Photo Update Partno from DSF-LSG-WX1-1 to DSF-LSG-WX1-4O9X DSF-LSG-W2X-4J8N Update Color Bin Structure	30 May 2017

NOTE

All the information contained in this document is considered to be reliable at the time of publishing. However, DOMINANT Opto Technologies does not assume any liability arising out of the application or use of any product described herein.

DOMINANT Opto Technologies reserves the right to make changes to any products in order to improve reliability, function or design.

DOMINANT Opto Technologies products are not authorized for use as critical components in life support devices or systems without the express written approval from the Managing Director of DOMINANT Opto Technologies.

About Us

DOMINANT Opto Technologies is a dynamic company that is amongst the world's leading automotive LED manufacturers. With an extensive industry experience and relentless pursuit of innovation, DOMINANT's state-of-art manufacturing and development capabilities have become a trusted and reliable brand across the globe. More information about DOMINANT Opto Technologies, a ISO/TS 16949 and ISO 14001 certified company, can be found under <http://www.dominant-semi.com>.

Please contact us for more information:

DOMINANT Opto Technologies Sdn. Bhd
Lot 6, Batu Berendam, FTZ Phase III, 75350 Melaka, Malaysia.
Tel: +606 283 3566 Fax: +606 283 0566
E-mail: sales@dominant-semi.com
