

DRAM

4M x 4 DYNAMIC RAM
EDO PAGE MODE

FEATURES

- Industry-standard x 4 pinouts and timing functions
- power supply : T2316405A 2.6V(±0.2V)
T2316407A 3.3V(±0.3V)
- All device pins are TTL- compatible.
- 2048-cycle refresh in 32 ms.
- Refresh modes: $\overline{\text{RAS}}$ only, $\overline{\text{CAS}}$ BEFORE $\overline{\text{RAS}}$ (CBR) and HIDDEN.
- Extended data-out (EDO) PAGE MODE access cycle.

OPTION

TIMING	MARKING
50ns (For T2316407A only)	-50
60ns (For T2316407A only)	-60
70ns (For T2316407A only)	-70
100ns (For T2316405A only)	-10

PACKAGE

26/24-pin SOJ	J
26/24-pin TSOP-II	S

PIN ARRANGEMENT (Top View)

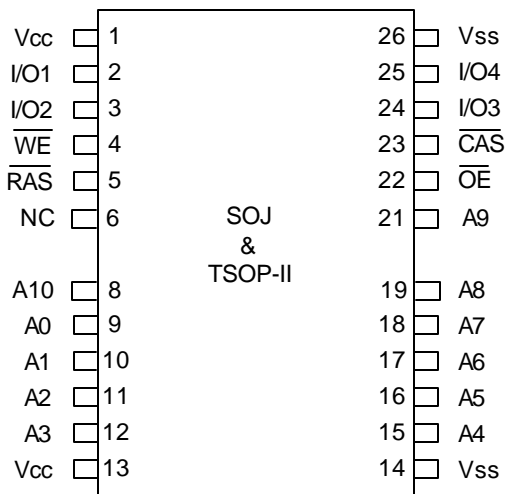

GRNERAL DESCRIPTION

The T2316405A and T2316407A is a randomly accessed solid state memory containing 16,777,216 bits organized in a x 4 configuration. It offers Fast Page mode with Extended Data Output (EDO).

During READ or WRITE cycles, each of the 4 memory bits (1 bit per I/O) is uniquely addressed through the 22 address bits, which are entered 11 bits (A0-A10) at a time. $\overline{\text{RAS}}$ latches the first 11 bits and $\overline{\text{CAS}}$ latches the latter 11 bits.

A READ or WRITE cycle is selected with the $\overline{\text{WE}}$ input. A logic HIGH on $\overline{\text{WE}}$ dictates READ mode while a logic LOW on $\overline{\text{WE}}$ dictates WRITE mode. During a WRITE cycle, data-in is latched by the falling edge of $\overline{\text{WE}}$ or $\overline{\text{CAS}}$, whichever occurs last. When $\overline{\text{WE}}$ goes Low prior to $\overline{\text{CAS}}$ going LOW (EARLY WRITE cycle), the output pins remain open (High-Z) until the next $\overline{\text{CAS}}$ cycle.

A Late Write or Read-Modify-Write occurs. When $\overline{\text{WE}}$ falls after $\overline{\text{CAS}}$ was taken LOW (Late Write cycle). $\overline{\text{OE}}$ must be taken HIGH to disable the data-outputs prior to applying input data.

The four data inputs and four data outputs are routed through four pins using common I/O, and pin direction is controlled by $\overline{\text{WE}}$ and $\overline{\text{OE}}$.

BLOCK DIAGRAM

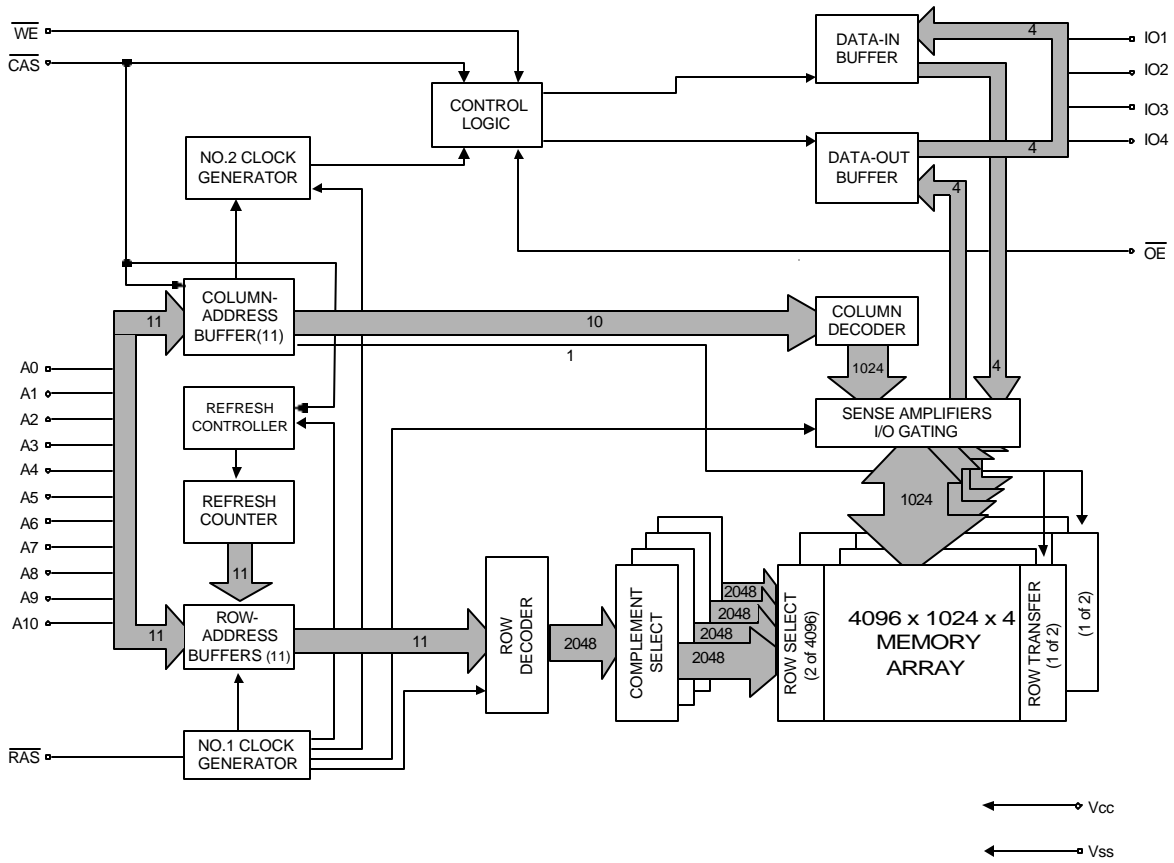

PIN DESCRIPTION

PIN NO.	SYM.	TYPE	DESCRIPTION
8~12,15~19,21	A0-A10	Input	Address Input
5	\overline{RAS}	Input	Row Address Strobe
23	\overline{CAS}	Input	Column Address Strobe
4	\overline{WE}	Input	Write Enable
22	\overline{OE}	Input	Output Enable
2,3,24,25	I/O1 -I/O4	Input/ Output	Data Input/ Output
1,13	Vcc	Supply	Power
14,26	Vss	Ground	Ground
6	NC		No Connect

ABSOLUTE MAXIMUM RATINGS

Parameter	Symbol	Value	Unit
Voltage on Any Pin Relative To V _{ss}	V _T	-0.5 to 4.6	V
Supply Voltage Relative To V _{ss}	V _{cc}	-0.5 to 4.6	V
Short circuit Output Current	I _{out}	50	mA
Power Dissipation	P _T	1	W
Operating Temperature	T _{OPR}	0 to 70	°C
Storage Temperature	T _{stg}	-55 to 125	°C

RECOMMENDED DC OPERATING CONDITIONS

(T_a = 0 to +70°C) For T2316405A-10 only

Parameter	Symbol	Min.	Typ	Max.	Unit	Notes
Supply Voltage	V _{ss}	0	0	0	V	
	V _{cc}	2.4	2.6	2.8	V	1
Input High Voltage	V _{IH}	2.0	-	V _{cc} +0.3V	V	1
Input Low Voltage	V _{IL}	-0.3	-	0.8	V	1

(T_a = 0 to +70°C) For T2316407A-50/60/70 only

Parameter	Symbol	Min.	Typ	Max.	Unit	Notes
Supply Voltage	V _{ss}	0	0	0	V	
	V _{cc}	3.0	3.3	3.6	V	1
Input High Voltage	V _{IH}	2.0	-	V _{cc} +0.3V	V	1
Input Low Voltage	V _{IL}	-0.3	-	0.8	V	1

Notes : 1. All voltages referenced to V_{ss}

DC CHARACTERISTICS

(Ta = 0 to 70°C) T2316405A-10 Vcc = 2.6V ± 0.2V, Vss = 0V

T2316407A-50/60/70 Vcc = 3.3V ± 0.3V, Vss = 0V

Parameter	Symbol	-50		-60		-70		-10		Unit	Test Condition
		Min	Max	Min	Max	Min	Max	Min	Max		
Input Leakage Current	I _{LI}	-5	5	-5	5	-5	5	-5	5	uA	0V ≤ Vin ≤ Vcc + 0.3V Other pins = 0V
Output Leakage Current	I _{LO}	-5	5	-5	5	-5	5	-5	5	uA	0V ≤ Vout ≤ Vcc Dout = disable
Output High Voltage	V _{OH}	2.0	-	2.0	-	2.0	-	2.0	-	V	High Iout = -2.0mA
Output Low Voltage	V _{OL}	-	0.8	-	0.8	-	0.8	-	0.8	V	Low Iout = 2.0mA
Operating Current	I _{cc1}	-	95	-	90	-	80	-	50	mA	RAS, CAS cycling t _{RC} = min
Standby Current	I _{cc2}	-	2	-	2	-	2	-	2	mA	TTL interface, RAS, CAS = VIH, DO _{OUT} = High-Z
Standby Current	I _{cc3}	-	0.5	-	0.5	-	0.5	-	0.5	mA	CMOS interface, RAS, CAS > Vcc - 0.2V
EDO Page Mode Current	I _{cc4}	-	95	-	90	-	80	-	50	mA	RAS = VIL, CAS cycling, t _{PC} = min
RAS-only refresh Current	I _{cc5}	-	95	-	90	-	80	-	50	mA	CAS = VIH, RAS cycling, t _{RC} = min
CAS Before RAS Refresh Current	I _{cc6}	-	95	-	90	-	80	-	50	mA	RAS, CAS cycling, t _{RC} = min

Note: I_{cc} depends on output load condition when the device is selected.

I_{cc} max is specified at the output open condition, I_{cc} is specified as an average current.

CAPACITANCE

(Ta = 25°C, f = 1M HZ, T2316405A-10 Vcc = 2.6V, T2316407A-50/60/70 Vcc = 3.3V)

Parameter	Symbol	Typ	Max	Unit
Input Capacitance (address)	C _{I1}	-	5	pF
Input Capacitance (RAS, CAS, WE, OE)	C _{I2}	-	7	pF
Output Capacitance (data-in/out)	C _{I/O}	-	7	pF

AC CHARACTERISTICS (note 1,2,3) (Ta = 0 to 70°C)

TEST CONDITIONS:

T2316405A-10 Vcc = 2.6V ±0.2V , T2316407A-50/60/70 Vcc = 3.3V ±0.3V

VIH/VIL=2.0/0.8V, VOH/VOL=2.0/0.8V

Input rise and fall times: 2ns , Output Load: 2TTL gate + CL (100pF)

AC CHARACTERISTICS PARAMETER	SYM	-50		-60		-70		-10		UNIT	Notes
		Min	Max	Min	Max	Min	Max	Min	Max		
Read or Write Cycle Time	t _{RC}	84		104		124		180		ns	
Read Write Cycle Time	t _{RWC}	108		135		160		240		ns	
EDO-Page-Mode Read or Write Cycle Time	t _{PC}	20		25		30		40		ns	
EDO-Page-Mode Read-Write Cycle Time	t _{PCM}	56		68		78		120		ns	
Access Time From $\overline{\text{RAS}}$	t _{RAC}		50		60		70		100	ns	4
Access Time From $\overline{\text{CAS}}$	t _{CAC}		13		15		20		25	ns	5
Access Time From $\overline{\text{OE}}$	t _{OAC}		13		15		20		25	ns	13
Access Time From Column Address	t _{AA}		25		30		35		50	ns	8
Access Time From $\overline{\text{CAS}}$ Precharge	t _{ACP}		30		35		40		55	ns	
$\overline{\text{RAS}}$ Pulse Width	t _{RAS}	50	10K	60	10K	70	10K	100	10K	ns	
$\overline{\text{RAS}}$ Pulse Width (EDO Page Mode)	t _{RASC}	50	100K	60	100K	70	100K	100	100K	ns	
$\overline{\text{RAS}}$ Hold Time	t _{RSH}	8		10		13		25		ns	
$\overline{\text{RAS}}$ Precharge Time	t _{RP}	30		40		50		70		ns	
$\overline{\text{CAS}}$ Pulse Width	t _{CAS}	8	10K	10	10K	13	10K	25	10K	ns	
$\overline{\text{CAS}}$ Hold Time	t _{CSH}	38		40		45		100		ns	
$\overline{\text{CAS}}$ Precharge Time (EDO Page Mode)	t _{CP}	10		10		10		10		ns	
$\overline{\text{RAS}}$ to $\overline{\text{CAS}}$ Delay Time	t _{RCD}	12	37	14	45	14	50	25	75	ns	7
$\overline{\text{CAS}}$ to $\overline{\text{RAS}}$ Precharge Time	t _{CRP}	5		5		5		5		ns	
Row Address Setup Time	t _{ASR}	0		0		0		0		ns	
Row Address Hold Time	t _{RAH}	8		10		10		15		ns	
$\overline{\text{RAS}}$ to Column Address Delay Time	t _{RAD}	10	25	12	30	12	35	20	50	ns	8
Column Address Setup Time	t _{ASC}	0		0		0		0		ns	
Column Address Hold Time	t _{CAH}	8		10		13		20		ns	
Column Address Hold Time (Reference to $\overline{\text{RAS}}$)	t _{AR}	21		24		27		45		ns	
Column Address to $\overline{\text{RAS}}$ Lead Time	t _{RAL}	25		30		35		50		ns	
Read Command Setup Time	t _{RCS}	0		0		0		0		ns	14
Read Command Hold Time Reference to $\overline{\text{CAS}}$	t _{RCH}	0		0		0		0		ns	9,14
Read Command Hold Time Reference to $\overline{\text{RAS}}$	t _{RRH}	0		0		0		0		ns	9
$\overline{\text{CAS}}$ to Output in Low-Z	t _{CLZ}	0		0		0		0		ns	
Output Buffer Turn-off Delay From $\overline{\text{CAS}}$ or $\overline{\text{RAS}}$	t _{OFF1}	0	12	0	15	0	20	0	25	ns	10,16

AC CHARACTERISTICS (continued)

AC CHARACTERISTICS PARAMETER	SYM	-50		-60		-70		-10		UNIT	Notes
		Min	Max	Min	Max	Min	Max	Min	Max		
Output Buffer Turn-off to \overline{OE}	t_{OFF2}	0	12	0	15	0	20	0	25	ns	16
Write Command Setup Time	t_{WCS}	0		0		0		0		ns	11,14
Write Command Hold Time	t_{WCH}	8		10		13		15		ns	
Write Command Hold Time (Reference to \overline{RAS})	t_{WCR}	21		24		27		40		ns	14
Write Command Pulse Width	t_{WP}	8		10		10		15		ns	14
Write Command to \overline{RAS} Lead Time	t_{RWL}	10		10		13		25		ns	14
Write Command to \overline{CAS} Lead Time	t_{CWL}	8		10		13		25		ns	14
Data-in Setup Time	t_{DS}	0		0		0		0		ns	12
Data-in Hold Time	t_{DH}	8		10		13		20		ns	12
Data-in Hold Time (Reference to \overline{RAS})	t_{DHR}	21		24		27		45		ns	
\overline{RAS} to \overline{WE} Delay Time	t_{RWD}	64		79		94		130		ns	11
Column Address to \overline{WE} Delay Time	t_{AWD}	39		49		59		80		ns	11
\overline{CAS} to \overline{WE} Delay Time	t_{CWD}	26		34		44		55		ns	11
Transition Time (rise or fall)	t_T	2	50	2	50	2	50	2	50	ns	2,3
Refresh Period (2048 cycles)	t_{REF}	32			32		32		32	ms	
\overline{RAS} to \overline{CAS} Precharge Time	t_{RPC}	5		5		5		5		ns	
\overline{CAS} Setup Time (CBR REFRESH)	t_{CSR}	5		10		10		10		ns	6
\overline{CAS} Hold Time (CBR REFRESH)	t_{CHR}	8		10		10		10		ns	6
\overline{OE} Hold Time From \overline{WE} During Read-Modify-Write Cycle	t_{OEH}	8		10		13		25		ns	15
\overline{OE} Low to \overline{CAS} High Setup Time	t_{OES}	5		5		5		5		ns	
\overline{OE} High Hold Time From \overline{CAS} High	t_{OEHC}	5		5		5		5		ns	
\overline{OE} High Pulse Width	t_{OEP}	10		10		10		10		ns	
\overline{OE} Setup Prior to \overline{RAS} During Hidden Refresh Cycle	t_{ORD}	5		7		10		13		ns	
Data Output Hold After \overline{CAS} Returning Low	t_{COH}	5		5		5		5		ns	
Output Disable Delay From \overline{WE}	t_{WHZ}		10		15		20		25	ns	

Notes:

1. An initial pause of 200us is required after power-up followed by eight $\overline{\text{RAS}}$ refresh cycles ($\overline{\text{RAS}}$ only or CBR) before proper device operation is assured. The eight $\overline{\text{RAS}}$ cycle wake-ups should be repeated any time the t_{REF} refresh requirement is exceeded.
2. $V_{\text{IH}}(2.0\text{V})$ and $V_{\text{IL}}(0.8\text{V})$ are reference levels for measuring timing of input signals. Transition times are measured between $V_{\text{IH}}(2.0\text{V})$ and $V_{\text{IL}}(0.8\text{V})$.
3. In addition to meet the transition rate specification, all input signals must transit between V_{IH} and V_{IL} in a monotonic manner.
4. Assume that $t_{\text{RCD}} < t_{\text{RCD}}(\text{max})$. If t_{RCD} is greater than the maximum recommended value shown in this table, t_{RAC} will increase by the amount that t_{RCD} exceeds the value shown.
5. Assume that $t_{\text{RCD}} \geq t_{\text{RCD}}(\text{max})$.
6. Enables on-chip refresh and address counters.
7. Operation within the $t_{\text{RCD}}(\text{max})$ limit ensures that $t_{\text{RAC}}(\text{max})$ can be met. $t_{\text{RCD}}(\text{max})$ is specified as a reference point only; if t_{RCD} is greater than the specified $t_{\text{RCD}}(\text{max})$ limit, access time is controlled by t_{CAC} .
8. Operation within the t_{RAD} limit ensures that $t_{\text{RAC}}(\text{max})$ can be met. $t_{\text{RAD}}(\text{max})$ is specified as a reference point only; if t_{RAD} is greater than the specified $t_{\text{RAD}}(\text{max})$ limit, access time is controlled by t_{AA} .
9. Either t_{RCH} or t_{RRH} must be satisfied for a READ cycle.
10. $t_{\text{OFF1}}(\text{max})$ defines the time at which the output achieves the open circuit condition; it is not a reference to V_{OH} or V_{OL} .
11. t_{WCS} , t_{RWD} , t_{AWD} and t_{CWD} are restrictive operating parameters in LATE WRITE and READ-MODIFY-WRITE cycles only. If $t_{\text{WCS}} \geq t_{\text{WCS}}(\text{min})$, the cycle is an EARLY WRITE cycle and the data output will remain an open circuit throughout the entire cycle. If $t_{\text{RWD}} \geq t_{\text{RWD}}(\text{min})$, $t_{\text{AWD}} \geq t_{\text{AWD}}(\text{min})$ and $t_{\text{CWD}} \geq t_{\text{CWD}}(\text{min})$, the cycle is READ-WRITE and the data output will contain data read from the selected cell. If neither of the above conditions is met, the state of I/O (at access time and until $\overline{\text{CAS}}$ and $\overline{\text{RAS}}$ or $\overline{\text{OE}}$ go back to V_{IH}) is indeterminate. $\overline{\text{OE}}$ held high and $\overline{\text{WE}}$ taken low after $\overline{\text{CAS}}$ goes low result in a LATE WRITE ($\overline{\text{OE}}$ - controlled) cycle.
12. These parameters are referenced to $\overline{\text{CAS}}$ leading edge in EARLY WRITE cycles and $\overline{\text{WE}}$ leading edge in LATE WRITE or READ-MODIFY-WRITE cycles.
13. During a READ cycle, if $\overline{\text{OE}}$ is low then taken HIGH before $\overline{\text{CAS}}$ goes high, I/O goes open, if $\overline{\text{OE}}$ is tied permanently low, a LATE WRITE or READ-MODIFY-WRITE operation is not possible.
14. WRITE command is defined as $\overline{\text{WE}}$ going low.
15. LATE WRITE and READ-MODIFY-WRITE cycles must have both t_{OFF2} and t_{OEH} met ($\overline{\text{OE}}$ high during WRITE cycle) in order to ensure that the output buffers will be open during the WRITE cycles.
16. The I/Os open during READ cycles once t_{OFF1} or t_{OFF2} occur.

READ WRITE CYCLE
(LATE WRITE and READ-MODIFY-WRITE CYCLES)

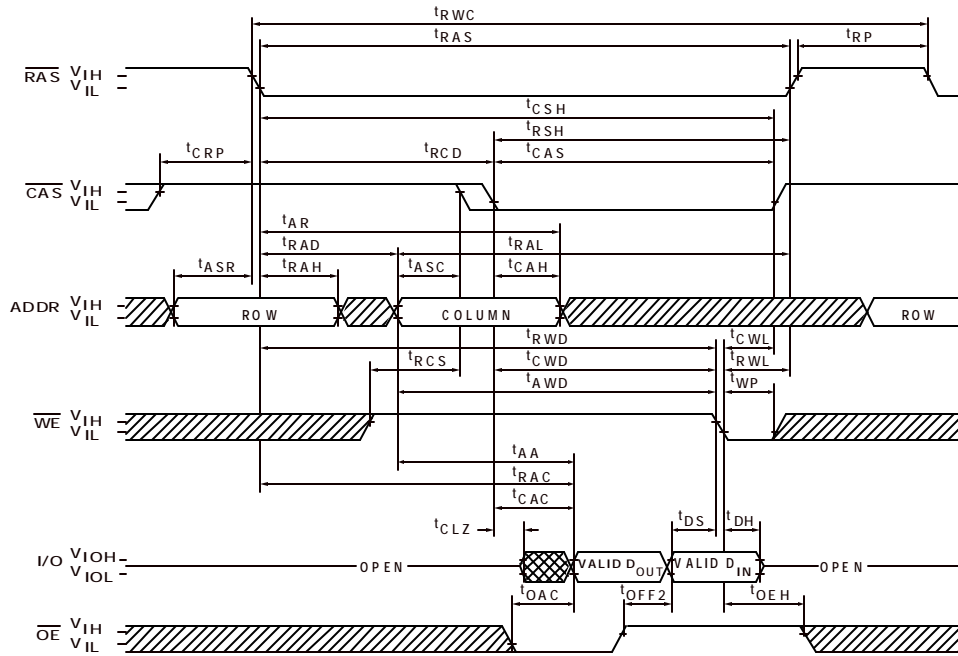

EDO-PAGE-MODE READ CYCLE

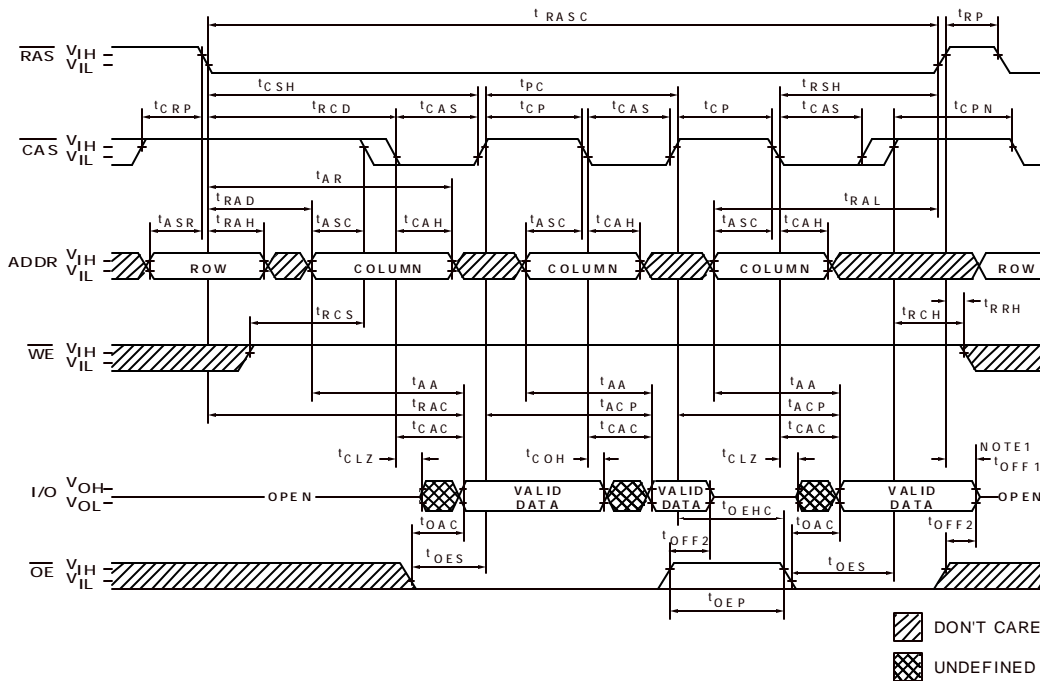

- Note:** 1. t_{OFF1} is referenced from the rising edge of \overline{RAS} or \overline{CAS} , whichever occurs last.
 2. t_{PC} can be measured from falling edge of \overline{CAS} to falling edge of \overline{CAS} , or from rising edge of \overline{CAS} to rising edge of \overline{CAS} . Both measurements must meet the t_{PC} specification.

EDO-PAGE-MODE READ-EARLY-WRITE CYCLE
(Pseudo READ-MODIFY-WRITE)

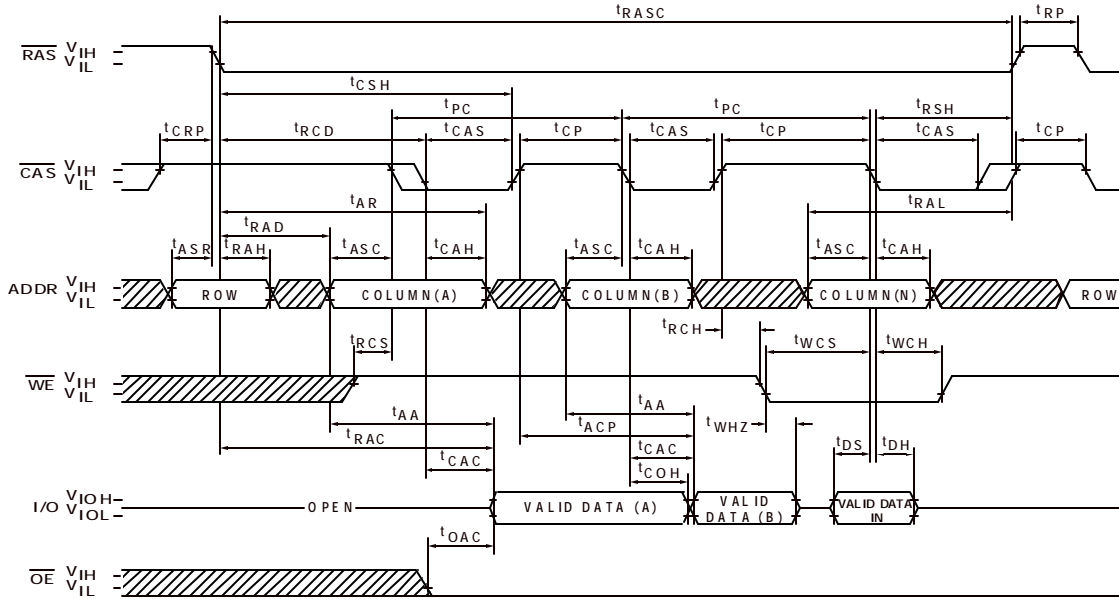

RAS ONLY REFRESH CYCLE
(ADDR=A0-A10; OE, WE =DON'T CARE)

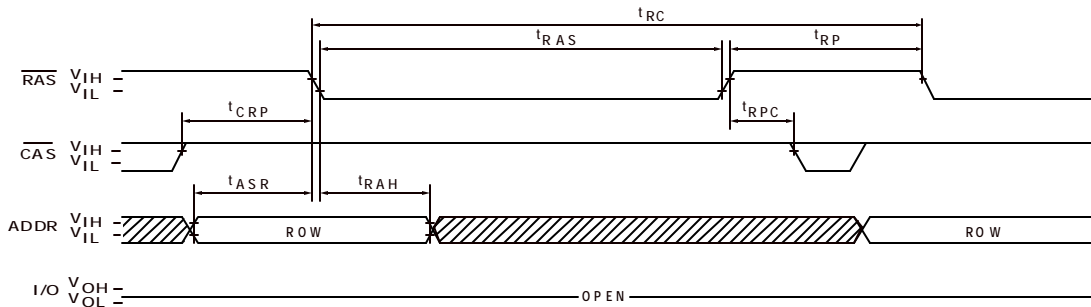

 DON'T CARE
 UNDEFINED

CBR REFRESH CYCLE
(A0-A10; \overline{OE} =DON'T CARE)

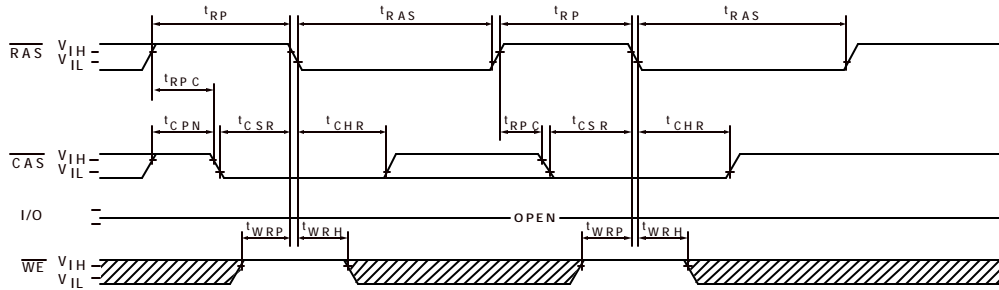

HIDDEN REFRESH CYCLE
(\overline{WE} =HIGH; \overline{OE} =LOW)

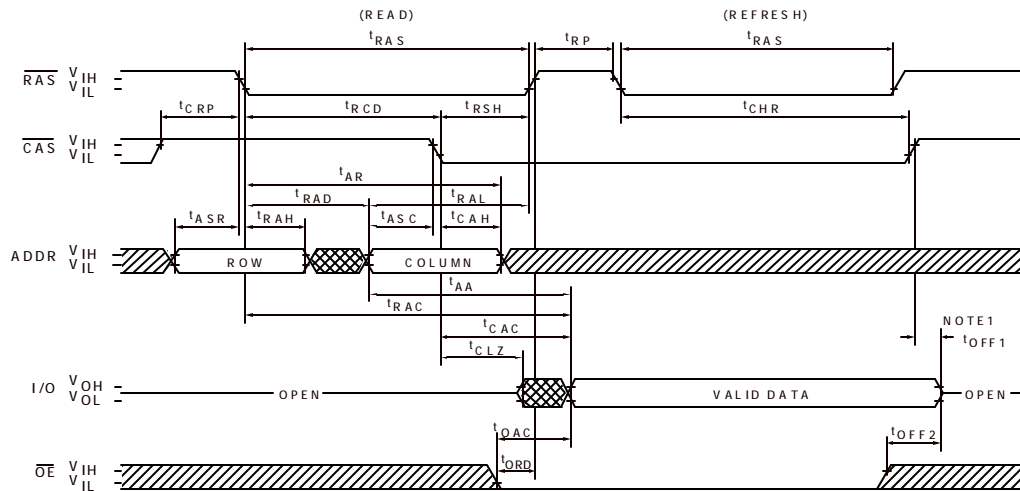

Note: 1. t_{OFF1} is referenced from the rising edge of \overline{RAS} or \overline{CAS} , whichever occurs last.

PACKAGE DIMENSIONS
24-LEAD SOJ DRAM (300 mil)

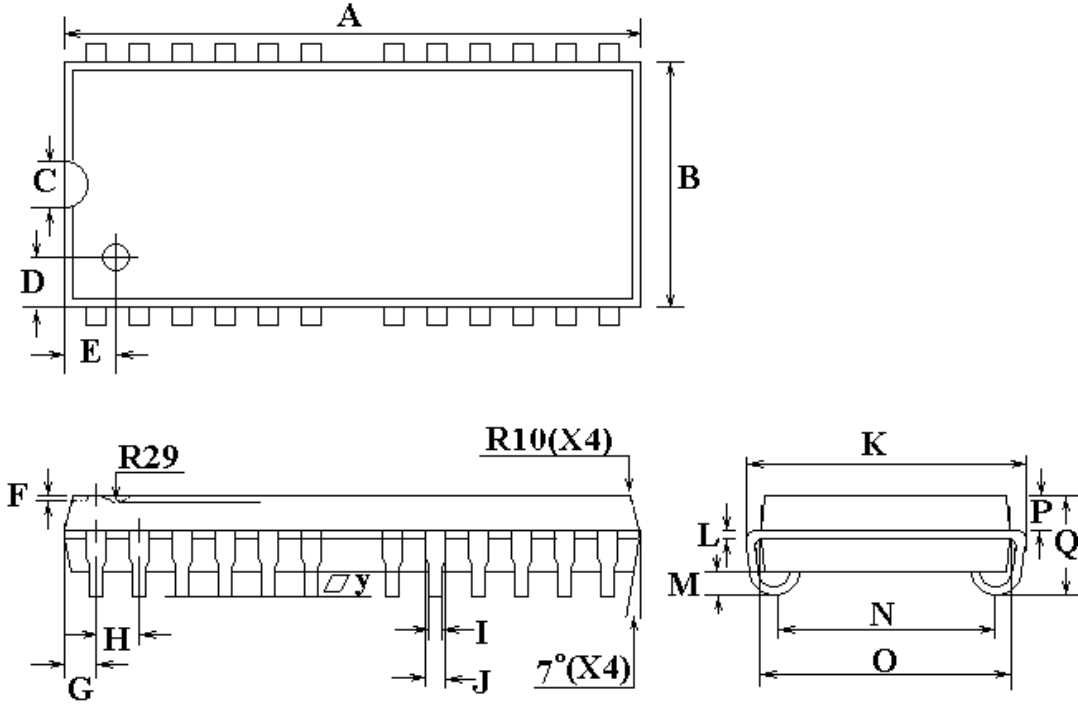

SYMBOL	DIMENSIONS IN INCHES	DIMENSIONS IN MM
A	0.673±0.002	17.09±0.05
B	0.300±0.002	7.62±0.13
C	0.060±0.002	1.52±0.05
D	0.050±0.001	1.27±0.03
E	0.063±0.001	1.63±0.03
F	0.015±0.002	0.38±0.05
G	0.036±0.002	0.91±0.05
H	0.050±0.002	1.27±0.05
I	0.018±0.002	0.46±0.05
J	0.028±0.002	0.71±0.05
K	0.336±0.003	8.53±0.08
L	0.010±0.001	0.25±0.03
M	0.029±0.002	0.74±0.05
N	0.268±0.003	6.81±0.08
O	0.300±0.002	7.62±0.05
P	0.042±0.001	1.07±0.03
Q	0.129±0.004	3.28±0.10
y	0.004(MAX)	0.102(MAX)

PACKAGE DIMENSIONS
24-LEAD TSOP II DRAM (300 mil)

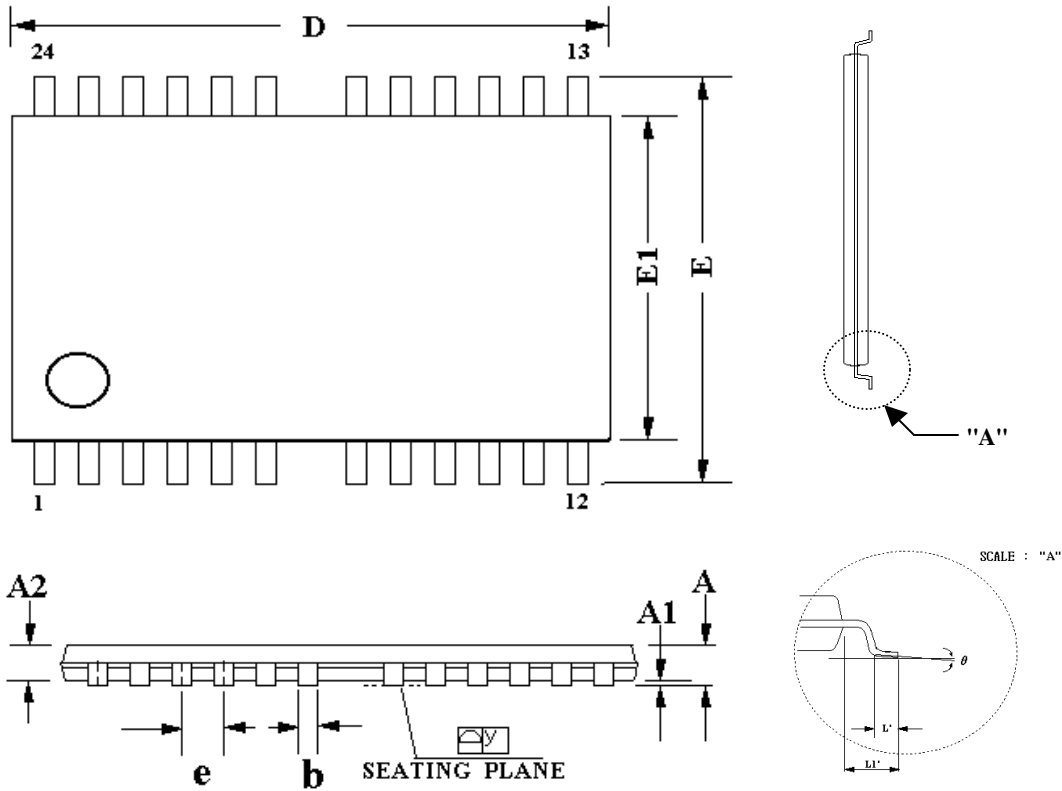

SYMBOL	DIMENSIONS IN INCHES	DIMENSIONS IN MM
A	0.047(MAX)	1.20(MAX)
A1	0.004±0.002	0.10±0.05
A2	0.039±0.002	1.00±0.05
b	0.016±0.004	0.41±0.11
D	0.675±0.005	17.14±0.13
E	0.368±0.003	9.22±0.20
E1	0.300±0.005	7.62±0.13
e	0.050	1.27
L'	0.020±0.004	0.50±0.10
L1'	0.031	0.80
y	0.002±0.002	0.05±0.05
θ	1°~ 5°	1°~ 5°