

TMS570LS Series 16/32-BIT RISC Flash Microcontroller

Check for Samples: [TMS570LS20216](#), [TMS570LS20206](#), [TMS570LS10216](#), [TMS570LS10206](#), [TMS570LS10116](#), [TMS570LS10106](#)

1 TMS570LS Series 16/32-BIT RISC Flash Microcontroller

1.1 Features

- **High-Performance Automotive Grade Microcontroller for Safety Critical Applications**
 - Certified for use in SIL3 Applications
 - Dual CPU's running in Lockstep
 - ECC on Flash and SRAM
 - CPU and Memory BIST (Built-In Self Test)
 - Error Signaling Module (ESM) w/ Error Pin
- **ARM® Cortex™-R4F 32-Bit RISC CPU**
 - Efficient 1.6 DMIPS/MHz with 8-stage pipeline
 - Floating Point Unit with Single/Double Precision
 - Memory Protection Unit (MPU)
 - Open Architecture With Third-Party Support
- **Operating Features**
 - Up to 160-MHz System Clock
 - Core Supply Voltage (V_{CC}): 1.5 V
 - I/O Supply Voltage (V_{CCIO}): 3.3 V
- **Integrated Memory**
 - 1M-Byte or 2M-Byte Flash with ECC
 - 128K-Byte or 160K-Byte RAM with ECC
- **Multiple Communication interfaces including Flexray, CAN, and LIN**
- **NHET Timer and 2x 12-bit ADC's**
- **External Memory Interface (EMIF)**
 - 16bit Data, 22bit Address, 4 Chip Selects
- **Common TMS470/570 Platform Architecture**
 - Consistent Memory Map across the family
 - Real-Time Interrupt (RTI) OS Timer
 - Vectored Interrupt Module (VIM)
 - Cyclic Redundancy Checker (CRC)
- **Direct Memory Access (DMA) Controller**
 - 32 Control Packets and 16 Channels
 - Parity on Control Packet Memory
 - Dedicated Memory Protection Unit (MPU)
- **Frequency-Modulated Zero-Pin Phase-Locked Loop (FMZPLL)-Based Clock Module**
 - Oscillator and PLL clock monitor
- **Up to 115 Peripheral IO pins**
 - 16 Dedicated GIO - 8 w/ External Interrupts
 - Programmable External Clock (ECLK)
- **Communication Interfaces**
 - Three Multi-buffered Serial Peripheral Interface (MibSPI) each with:
 - Four chip selects and one Enable pin
 - 128 buffers with parity
 - One with parallel mode
 - Two UART (SCI) interfaces with Local Interconnect Network Interface (LIN 2.0)
 - Three CAN (DCAN) Controller
 - Two with 64 mailboxes, one with 32
 - Parity on mailbox RAM
 - Dual Channel FlexRay™ Controller
 - 8K-Byte message RAM with parity
 - Transfer Unit with MPU and parity
- **High-End Timer (nHET)**
 - 32 Programmable I/O Channels
 - 128 Words High-End Timer RAM with parity
 - Transfer Unit with MPU and parity
- **Two 12-Bit Multi-Buffered ADCs (MibADC)**
 - 24 total ADC Input channels
 - Each has 64 Buffers with parity
- **Trace and Calibration Interfaces**
 - Embedded Trace Module (ETMR4)
 - Data Modification Module (DMM)
 - RAM Trace Port (RTP)
 - Parameter Overlay Module (POM)
- **On-Chip emulation logic including IEEE 1149.1 JTAG, Boundary Scan and ARM Coresight components**
- **Full Development Kit Available**
 - Development Boards
 - Code Composer Studio Integrated Development Environment (IDE)
 - HaLCoGen Code Generation Tool
 - HET Assembler and Simulator
 - nowFlash Flash Programming Tool
- **Packages Supported**
 - 144-Pin Quad Flatpack (PGE) [Green]
 - 337-Pin Ball Grid Array (ZWT) [Green]
- **Community Resources**
 - [TI E2E Community](#)



Please be aware that an important notice concerning availability, standard warranty, and use in critical applications of Texas Instruments semiconductor products and disclaimers thereto appears at the end of this data sheet.

All trademarks are the property of their respective owners.

1.2 Description

The TMS570LS series is a high performance automotive grade microcontroller family which has been certified for use in IEC 61508 SIL3 safety systems. The safety architecture includes Dual CPUs in lockstep, CPU and Memory Built-In Self Test (BIST) logic, ECC on both the Flash and the data SRAM, parity on peripheral memories, and loop back capability on peripheral IOs.

The TMS570LS family integrates the ARM® Cortex™-R4F Floating Point CPU which offers an efficient 1.6 DMIPS/MHz, and has configurations which can run up to 160 MHz providing more than 250 DMIPS. The TMS570LS series also provides different Flash (1MB or 2MB) and data SRAM (128KB or 160KB) options with single bit error correction and double bit error detection.

The TMS570LS devices feature peripherals for real-time control-based applications, including up to 32 nHET timer channels and two 12-bit A to D converters supporting up to 24 inputs. There are multiple communication interfaces including a 2-channel Flexray, 3 CAN controllers supporting 64 mailboxes each, and 2 LIN/UART controllers.

With integrated SIL3 certified safety features and a wide choice of communication and control peripherals, the TMS570LS series is an ideal solution for high performance real time control applications with safety critical requirements.

The devices included in the TMS570LS series and described in this document are:

- TMS570LS20216
- TMS570LS20206
- TMS570LS10216
- TMS570LS10206
- TMS570LS10116
- TMS570LS10106

The TMS570LS series microcontrollers contain the following:

- Dual TMS570 16/32-Bit RISC (ARM Cortex™-R4F) in Lockstep
- Up to 2M-Byte Program Flash with ECC
- Up to 160K-Byte Static RAM (SRAM) with ECC
- Real-Time Interrupt (RTI) Operating System Timer
- Vectored Interrupt Module (VIM)
- Cyclic Redundancy Checker (CRC) with Parallel Signature Analysis (PSA)
- Direct Memory Access (DMA) Controller
- Frequency-Modulated Phase-Locked Loop (FMZPLL)-Based Clock Module With Prescaler
- Three Multi-buffered Serial Peripheral Interfaces (MibSPI)
- Two UARTs (SCI) with Local Interconnect Network Interfaces (LIN)
- Three CAN Controllers (DCAN)
- High-End Timer (NHET) with dedicated Transfer Unit (HTU)
- Available FlexRay Controller with dedicated PLL and Transfer Unit (FTU)
- External Clock Prescale (ECP) Module
- Two 16-Channel 12-Bit Multi-Buffered ADCs (MibADC) - 8 shared channels between the two ADCs
- System Bus Parity with Failure Detection
- Error Signaling Module (ESM) with external error pin
- Voltage Monitor (VMON) with out of range reset assertion
- Embedded Trace Module (ETMR4)
- Data Modification Module (DMM)
- RAM Trace Port (RTP)
- Parameter Overlay Module (POM)

- 16 Dedicated General-Purpose I/O (GIO) Pins for ZWT; 8 Dedicated GIO Pins for PGE
- 115 Total Peripheral I/Os for ZWT; 68 Total Peripheral I/Os for PGE
- 16-Bit External Memory Interface (EMIF)

The devices utilize the big-endian format where the most significant byte of a word is stored at the lowest numbered byte and the least significant byte at the highest numbered byte.

The device memory includes general-purpose SRAM supporting single-cycle read/write accesses in byte, halfword, and word modes. The flash memory on this device is a nonvolatile, electrically erasable and programmable memory implemented with a 64-bit-wide data bus interface. The flash operates on a 3.3V supply input (same level as I/O supply) for all read, program and erase operations. When in pipeline mode, the flash operates with a system clock frequency of up to 160 MHz.

The device has nine communication interfaces: three MibSPIs, two LIN/SCIs, three DCANs and one FlexRay™ controller (optional). The SPI provides a convenient method of serial interaction for high-speed communications between similar shift-register type devices. The LIN supports the Local Interconnect standard 2.0 and can be used as a UART in full-duplex mode using the standard Non-Return-to-Zero (NRZ) format. The DCAN supports the CAN 2.0B protocol standard and uses a serial, multimaster communication protocol that efficiently supports distributed real-time control with robust communication rates of up to 1 megabit per second (Mbps). The DCAN is ideal for applications operating in noisy and harsh environments (e.g., automotive and industrial fields) that require reliable serial communication or multiplexed wiring. The FlexRay uses a dual channel serial, fixed time base multimaster communication protocol with communication rates of 10 megabits per second (Mbps) per channel. A FlexRay Transfer Unit (FTU) enables autonomous transfers of FlexRay data to and from main CPU memory. Transfers are protected by a dedicated, built-in Memory Protection Unit (MPU).

The NHET is an advanced intelligent timer that provides sophisticated timing functions for real-time applications. The timer is software-controlled, using a reduced instruction set, with a specialized timer micromachine and an attached I/O port. The NHET can be used for pulse width modulated outputs, capture or compare inputs, or general-purpose I/O.. It is especially well suited for applications requiring multiple sensor information and drive actuators with complex and accurate time pulses. A High End Timer Transfer Unit (HET-TU) provides features to transfer NHET data to or from main memory. A Memory Protection Unit (MPU) is built into the HET-TU to protect against erroneous transfers.

The device has two 12-bit-resolution MibADCs with 24 total channels and 64 words of parity protected buffer RAM each. The MibADC channels can be converted individually or can be grouped by software for sequential conversion sequences. Eight channels are shared between the two ADCs. There are three separate groupings, two of which are triggerable by an external event. Each sequence can be converted once when triggered or configured for continuous conversion mode.

The frequency-modulated phase-locked loop (FMZPLL) clock module contains a phase-locked loop, a clock-monitor circuit, a clock-enable circuit, and a prescaler. The function of the FMZPLL is to multiply the external frequency reference to a higher frequency for internal use. The FMZPLL provides one of the six possible clock source inputs to the global clock module (GCM). The GCM module provides system clock (HCLK), real-time interrupt clock (RTICK1), CPU clock (GCLK), NHET clock (VCLK2), DCAN clock (AVCLK1), and peripheral interface clock (VCLK) to all other peripheral modules.

The device also has an external clock prescaler (ECP) module that when enabled, outputs a continuous external clock on the ECLK pin. The ECLK frequency is a user-programmable ratio of the peripheral interface clock (VCLK) frequency.

The Direct Memory Access Controller (DMA) has 16 channels, 32 control packets and parity protection on its memory. The DMA provides memory to memory transfer capabilities without CPU interaction. A Memory Protection Unit (MPU) is built into the DMA to protect memory against erroneous transfers.

The Error Signaling Module (ESM) monitors all device errors and determines whether an interrupt or external Error pin is triggered when a fault is detected.

The External Memory Interface (EMIF) provides a memory extension to asynchronous memories or other slave devices.

Several interfaces are implemented to enhance the debugging capabilities of application code. In addition to the built in ARM Cortex™-R4F CoreSight™ debug features, an External Trace Macrocell (ETM) provides instruction and data trace of program execution. For instrumentation purposes, a RAM Trace Port Module (RTP) is implemented to support high-speed output of RAM accesses by the CPU or any other master. A Direct Memory Module (DMM) gives the ability to write external data into the device memory. Both the RTP and DMM have no or only minimum impact on the program execution time of the application code. A Parameter Overlay Module (POM) can re-route Flash accesses to the EMIF, thus avoiding the re-programming steps necessary for parameter updates in Flash.

PRODUCT PREVIEW

1.3 Functional Block Diagram

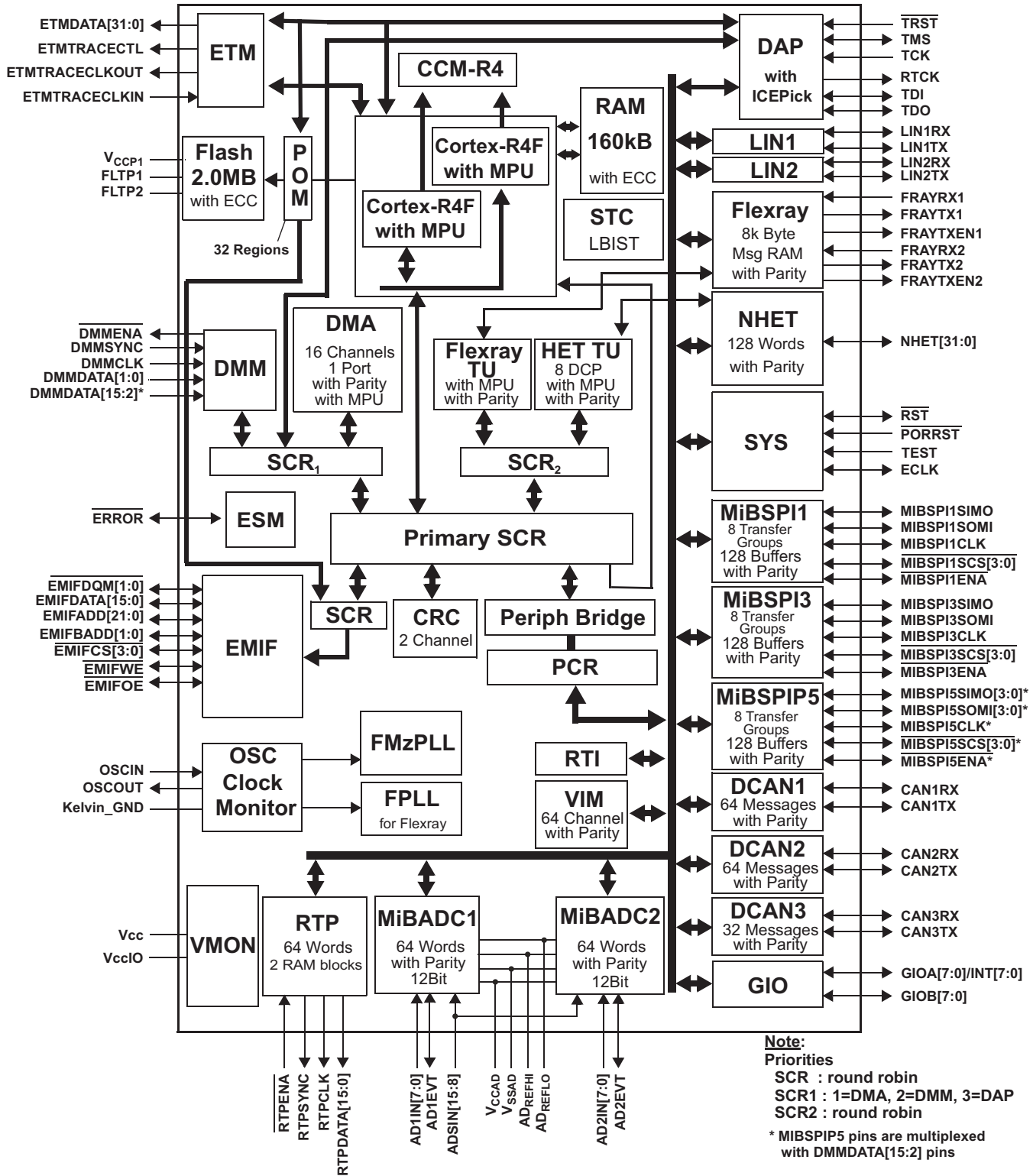

PRODUCT PREVIEW

1	TMS570LS Series 16/32-BIT RISC Flash Microcontroller	1	5.1	Device Identification Code Register	56
1.1	Features	1	5.2	Die-ID Registers	58
1.2	Description	2	5.3	PLL Registers	59
1.3	Functional Block Diagram	5	6	Device Electrical Specifications	60
2	Device Overview	7	6.1	Operating Conditions	60
2.1	Device Characteristics	7	6.2	Absolute Maximum Ratings Over Operating Free-Air Temperature Range (unless otherwise noted)	60
2.2	Memory	8	6.3	Device Recommended Operating Conditions	60
2.3	Pin Assignments	16	6.4	Electrical Characteristics Over Operating Free-Air Temperature Range	61
2.4	Terminal Functions	21	7	Peripheral and Electrical Specifications	66
2.5	Device Support	34	7.1	Clocks	66
3	Reset / Abort Sources	36	7.2	ECLK Specification	69
3.1	Reset / Abort Sources	36	7.3	RST And PORRST Timings	70
4	Peripherals	39	7.4	DAP - JTAG Scan Interface Timing	72
4.1	Error Signaling Module (ESM)	39	7.5	Output Timings	73
4.2	Direct Memory Access (DMA)	42	7.6	Input Timings	74
4.3	High End Timer Transfer Unit (HET-TU)	43	7.7	Flash Timings	75
4.4	Vectored Interrupt Manager (VIM)	44	7.8	SPI Master Mode Timing Parameters	76
4.5	MIBADC Event Trigger Sources	46	7.9	SPI Slave Mode Timing Parameters	80
4.6	MIBSPI	47	7.10	CAN Controller Mode Timings	84
4.7	ETM	49	7.11	Flexray Controller Mode Timings	84
4.8	Debug Scan Chains	49	7.12	EMIF Timings	85
4.9	CCM	51	7.13	ETM Timings	87
4.10	LPM	52	7.14	RTP Timings	88
4.11	Voltage Monitor	52	7.15	DMM Timings	90
4.12	CRC	52	7.16	MibADC	91
4.13	System Module	52	8	Mechanical Packaging and Orderable Information	97
4.14	Debug ROM	53	8.1	Thermal Data	97
4.15	CPU Self Test Controller: STC / LBIST	54	8.2	Packaging Information	97
5	Device Registers	56			

2 Device Overview

2.1 Device Characteristics

The table below shows the different configurations options offered in the TMS570LS series of devices:

Table 2-1. Characteristics of the TMS570LS Series Devices

Feature	TMS570LS20216		TMS570LS20206		TMS570LS10216		TMS570LS10206		TMS570LS10116		TMS570LS10106	
	337 BGA (ZWT)	144 QFP (PGE)	337 BGA (ZWT)	144 QFP (PGE)	337 BGA (ZWT)	144 QFP (PGE)	337 BGA (ZWT)	144 QFP (PGE)	337 BGA (ZWT)	144 QFP (PGE)	337 BGA (ZWT)	144 QFP (PGE)
Package	337 BGA	144 QFP	337 BGA	144 QFP	337 BGA	144 QFP	337 BGA	144 QFP	337 BGA	144 QFP	337 BGA	144 QFP
Type	(ZWT)	(PGE)	(ZWT)	(PGE)	(ZWT)	(PGE)	(ZWT)	(PGE)	(ZWT)	(PGE)	(ZWT)	(PGE)
Speed	160MHz	140MHz	160MHz	140MHz	160MHz	140MHz	160MHz	140MHz	160MHz	140MHz	160MHz	140MHz
Flash Size	2MB	2MB	2MB	2MB	1MB	1MB	1MB	1MB	1MB	1MB	1MB	1MB
RAM Size	160KB	160KB	160KB	160KB	160KB	160KB	160KB	160KB	160KB	160KB	128KB	128KB
FlexRay	2ch	2ch	-	-	2ch	2ch	-	-	2ch	2ch	-	-
CAN	3	2	3	2	3	2	3	2	3	2	3	2
MibSPI	3	3	3	3	3	3	3	3	3	3	3	3
UART / LIN	2	2	2	2	2	2	2	2	2	2	2	2
NHET Channels	32	25	32	25	32	25	32	25	32	25	32	25
12 Bit ADC Channels	24	20	24	20	24	20	24	20	24	20	24	20
EMIF	16-bit	-	16-bit	-	16-bit	-	16-bit	-	16-bit	-	16-bit	-
GIO	16	8	16	8	16	8	16	8	16	8	16	8
ETM	32-bit	-	32-bit	-	32-bit	-	32-bit	-	32-bit	-	32-bit	-
RTP	16-bit	-	16-bit	-	16-bit	-	16-bit	-	16-bit	-	16-bit	-
DMM	16-bit	-	16-bit	-	16-bit	-	16-bit	-	16-bit	-	16-bit	-

PRODUCT PREVIEW

2.2 Memory

2.2.1 Memory Map

The memory map including all available Flash and RAM memory configurations for the device family are shown in the [Figure 2-1](#) figure below.

0xFFFFFFFF	SYSTEM Modules		
0xFFFF80000			
0xFFFF7FFFF	Peripherals		
0xFF000000			
0xFEFFFFFFF	CRC		
0xFE000000			
	RESERVED		
0x6FFFFFFF	CS3	EMIF (256MB)	
	CS2		
	CS1		
	CS0		POM (4MB)
0x60000000			0x603FFFFF 0x60000000
	RESERVED		
0x204FFFFFF			0x204FFFFFF
	Flash - ECC^(a) (2MB Mirrored Image)	RESERVED	0x2047FFFF
0x20400000		Flash - ECC^{(1MB)^(b)}	0x20400000
	RESERVED		
0x201FFFFFF			0x201FFFFFF
	Flash (2MB)^(a) (Mirrored Image)	RESERVED	0x200FFFFF
0x20000000		Flash (1MB)^(b) (Mirrored Image)	0x20000000
	RESERVED		
0x08427FFF			0x08427FFF
	RAM - ECC^{(160kB)^(c)}	RESERVED	0x08401FFF
0x08400000		RAM - ECC^{(128kB)^(d)}	0x08400000
	RESERVED		
0x08027FFF			0x08027FFF
	RAM (160kB)^(c)	RESERVED	0x0801FFFF
0x08000000		RAM (128kB)^(d)	0x08000000
	RESERVED		
0x004FFFFFF			0x004FFFFFF
	Flash-ECC^{(2MB)^(a)}	RESERVED	0x0047FFFF
0x00400000		Flash - ECC^{(1MB)^(b)}	0x00400000
	RESERVED		
0x001FFFFFF			0x001FFFFFF
	Flash (2MB)^(a)	RESERVED	0x000FFFFF
0x00000000		Flash (1MB)^(b)	0x00000000

- (a) 2MB Flash Devices
- (b) 1MB Flash Devices
- (c) 160kB RAM Devices
- (d) 128kB RAM Devices

Figure 2-1. Memory Map

PRODUCT PREVIEW

The Parameter Overlay memory space maps to the lower 4MB of the EMIF CS0 memory space. ECC must be disabled by software via the CPU CP15 register if POM is used to overlay the program memory to the EMIF space; otherwise ECC errors will be generated. The contents of memory connected to the EMIF are not guaranteed after a power on reset. The addressable EMIF memory range is limited to the lower 32MB of each EMIF chip select for 16bit memories, and to the lower 16MB of each EMIF chip select for 8bit memories. The default EMIF data width is 16bit.

2.2.2 Flash Memory

The F035 (130nm Flash Process) Flash memory is a nonvolatile electrically erasable and programmable memory. The Flash has a state machine for simplifying the program and erase functions.

This device's 2M-byte flash memory contains four 512K-byte memory arrays (or banks) consisting of 22 total sectors. 1M-byte versions of the device contain only the first two 512K-byte banks (Bank 0 and Bank 1) and have a total of 14 sectors. The bank and sector configurations are shown in Flash Memory Banks and Sectors . When in pipeline mode, the Flash operates with a system clock frequency of up to 160MHz (versus a system clock in non-pipeline mode of up to 36MHz). The flash in pipeline mode is capable of accessing 128 bits at a time and provides two 64-bit pipelined words to the CPU. The minimum size for an erase operation is one sector. A single program operation can program either one 32-bit word or one 16-bit half word at a time.

Table 2-2. Flash Memory Banks and Sectors

Sector NO.	Segment	Low Address	High address	MEMORY ARRAYS (OR BANKS)
Bank 0: 512K Bytes				
0	32K Bytes	0x0000_0000	0x0000_7FFF	BANK0 (512k Bytes)
1	32K Bytes	0x0000_8000	0x0000_FFFF	
2	32K Bytes	0x0001_0000	0x0001_7FFF	
3	8K Bytes	0x0001_8000	0x0001_9FFF	
4	8K Bytes	0x0001_A000	0x0001_BFFF	
5	16K Bytes	0x0001_C000	0x0001_FFFF	
6	64K Bytes	0x0002_0000	0x0002_FFFF	
7	64K Bytes	0x0003_0000	0x0003_FFFF	
8	128K Bytes	0x0004_0000	0x0005_FFFF	
9	128K Bytes	0x0006_0000	0x0007_FFFF	
Bank 1: 512K Bytes				
0	128K Bytes	0x0008_0000	0x0009_FFFF	BANK1 (512k Bytes)
1	128K Bytes	0x000A_0000	0x000B_FFFF	
2	128K Bytes	0x000C_0000	0x000D_FFFF	
3	128K Bytes	0x000E_0000	0x000F_FFFF	
Bank 2: 512K Bytes				
0	128K Bytes	0x0010_0000	0x0011_FFFF	BANK2 (512k Bytes)
1	128K Bytes	0x0012_0000	0x0013_FFFF	
2	128K Bytes	0x0014_0000	0x0015_FFFF	
3	128K Bytes	0x0016_0000	0x0017_FFFF	
Bank 3: 512K Bytes				
0	128K Bytes	0x0018_0000	0x0019_FFFF	BANK3 (512k Bytes)
1	128K Bytes	0x001A_0000	0x001B_FFFF	
2	128K Bytes	0x001C_0000	0x001D_FFFF	
3	128K Bytes	0x001E_0000	0x001F_FFFF	

NOTE

The external flash pump voltage (VccP) is required for all flash operations (program, erase, and read).

NOTE

After a system reset, pipeline mode is disabled (FRDCNTL[2:0] is a "000"). In other words, the device powers up and comes out of reset in non-pipeline mode.

PRODUCT PREVIEW

2.2.3 System Modules Assignment

This table shows the memory map for the Cyclic Redundancy Check (CRC) module, the Cortex™-R4F CoreSight™ debug module, and the System modules.

Table 2-3. System Modules Assignment

Frame Name	Address Range	
	Frame Start Address	Frame Ending Address
CRC	0xFE00_0000	0xFEFF_FFFF
CoreSight Debug ROM Register	0xFFA0_0000	0xFFA0_0FFF
Cortex-R4F Debug Register	0xFFA0_1000	0xFFA0_1FFF
ETM-R4 Register	0xFFA0_2000	0xFFA0_2FFF
CoreSight TPIU Register	0xFFA0_3000	0xFFA0_3FFF
POM Register	0xFFA0_4000	0xFFA0_4FFF
DMA RAM	0xFFF8_0000	0xFFF8_0FFF
VIM RAM	0xFFF8_2000	0xFFF8_2FFF
RTP RAM	0xFFF8_3000	0xFFF8_3FFF
Flash Wrapper Register	0xFFF8_7000	0xFFF8_7FFF
PCR Register	0xFFFF_E000	0xFFFF_E0FF
Flexray PLL/STC CLK Register	0xFFFF_E100	0xFFFF_E1FF
PBIST Register	0xFFFF_E400	0xFFFF_E5FF
STC Register	0xFFFF_E600	0xFFFF_E6FF
EMIF Register	0xFFFF_E800	0xFFFF_E8FF
DMA Register	0xFFFF_F000	0xFFFF_F3FF
ESM Register	0xFFFF_F500	0xFFFF_F5FF
CCMR4 Register	0xFFFF_F600	0xFFFF_F6FF
DMM Register	0xFFFF_F700	0xFFFF_F7FF
RAM ECC even Register	0xFFFF_F800	0xFFFF_F8FF
RAM ECC odd Register	0xFFFF_F900	0xFFFF_F9FF
RTP Register	0xFFFF_FA00	0xFFFF_FAFF
RTI Register	0xFFFF_FC00	0xFFFF_FCFF
VIM Parity Register	0xFFFF_FD00	0xFFFF_FDFF
VIM Register	0xFFFF_FE00	0xFFFF_FEFF
System Register	0xFFFF_FF00	0xFFFF_FFFF

2.2.4 Peripheral Selects

The peripheral frame contains the memory map for the peripheral registers as well as the peripheral memories. The first table shows the memory map for the peripheral module registers and following table shows the memory map for the peripheral module memories.

Table 2-4. Peripheral Select Assignment

Peripheral Module	Address Range		Peripheral Selects
	Base Address	Ending Address	
MIBSPI5	0xFFFF7_FC00	0xFFFF7_FDFE	PS[0]
MIBSPI3	0xFFFF7_F800	0xFFFF7_F9FF	PS[1]
MIBSPI1	0xFFFF7_F400	0xFFFF7_F5FF	PS[2]
LIN2	0xFFFF7_E500	0xFFFF7_E5FF	PS[6]
LIN1	0xFFFF7_E400	0xFFFF7_E4FF	
DCAN3	0xFFFF7_E000	0xFFFF7_E1FF	PS[7]
DCAN2	0xFFFF7_DE00	0xFFFF7_DFFF	PS[8]
DCAN1	0xFFFF7_DC00	0xFFFF7_DDFF	
Flexray	0xFFFF7_C800	0xFFFF7_CFFF	PS[12]+PS[13]
MIBADC2	0xFFFF7_C200	0xFFFF7_C3FF	PS[15]
MIBADC1	0xFFFF7_C000	0xFFFF7_C1FF	
GIO	0xFFFF7_BC00	0xFFFF7_BCFE	PS[16]
NHET	0xFFFF7_B800	0xFFFF7_B8FF	PS[17]
HET TU	0xFFFF7_A400	0xFFFF7_A4FF	PS[22]
Flexray TU	0xFFFF7_A000	0xFFFF7_A1FF	PS[23]

Table 2-5. Peripheral Memory Selects

Peripheral Module Memory	Address Range		Peripheral Selects
	Base Address	Ending Address	
MIBSPI5 RAM	0xFF0A0000	0xFF0BFFFF	PCS[5]
MIBSPI3 RAM	0xFF0C0000	0xFF0DFFFF	PCS[6]
MIBSPI1 RAM	0xFF0E0000	0xFF0FFFFFFF	PCS[7]
DCAN3 RAM	0xFF1A0000	0xFF1BFFFF	PCS[13]
DCAN2 RAM	0xFF1C0000	0xFF1DFFFF	PCS[14]
DCAN1 RAM	0xFF1E0000	0xFF1FFFFFFF	PCS[15]
MIBADC2 RAM	0xFF3A0000	0xFF3BFFFF	PCS[29]
MIBADC1 RAM	0xFF3E0000	0xFF3FFFFFFF	PCS[31]
NHET RAM	0xFF460000	0xFF47FFFF	PCS[35]
HET TU RAM	0xFF4E0000	0xFF4FFFFFFF	PCS[39]
Flexray TU RAM	0xFF500000	0xFF51FFFF	PCS[40]

PRODUCT PREVIEW

2.2.5 Memory Auto-Initialization

This device allows some of the on-chip memories to be initialized via the memory hardware initialization control registers in the System module. The purpose of having the hardware initialization is to program the memory arrays with error detection capability to a known state based on their error detection scheme (odd/even parity or ECC). The MINITGCR register enables the memory initialization sequence, and the MSINENA register selects the memories that are to be initialized. Please refer to the Architecture chapter of the Technical Reference Manual (TRM) for more information.

The mapping of the different memories to the specific bits in the MSINENA register is shown in the following table.

Table 2-6. Memory Initialization

Connecting Module	Address Range		RAM Select
	Base Address	Ending Address	
RAM	0x08000000	0x0801FFFF	0
MIBSPI5 RAM	0xFF0A0000	0xF0BFFFFFFF	12
MIBSPI3 RAM	0xFF0C0000	0xFF0DFFFFFF	11
MIBSPI1 RAM	0xFF0E0000	0xFF0FFFFFFF	7
DCAN3 RAM	0xFF1A0000	0xFF1BFFFFFF	10
DCAN2 RAM	0xFF1C0000	0xFF1DFFFFFF	6
DCAN1 RAM	0xFF1E0000	0xFF1FFFFFFF	5
Flexray RAM	RAM is not visible		9
MIBADC2 RAM	0xFF3A0000	0xFF3BFFFFFF	14
MIBADC1 RAM	0xFF3E0000	0xFF3FFFFFFF	8
NHET RAM	0xFF460000	0xFF47FFFFFF	3
HET TU RAM	0xFF4E0000	0xFF4FFFFFFF	4
DMA RAM	0xFFF80000	0xFFF80FFF	1
VIM RAM	0xFFF82000	0xFFF82FFF	2
Flexray TU RAM	0xFF500000	0xFF51FFFF	13

2.2.6 PBIST RAM Self Test

The PBIST (Programmable Built-In Self Test) architecture provides a run-time-programmable memory BIST engine for varying levels of test coverage across the device's embedded RAM memory. The PBIST architecture consists of a small CPU with an instruction set targeted specifically towards testing RAM memories. This CPU includes both control and instruction registers necessary to execute the individual memory algorithms. In order to minimize test load overhead, once an algorithm is loaded into the instruction registers, it can be run on multiple memories of different sizes or types. The memory configuration information and test algorithm code is stored in an on-chip ROM. The PBIST RAM groups implemented on this device are shown in the following table. More information about memory self test can be found in the PBIST chapter of the device TRM.

Table 2-7. PBIST RAM Grouping

RAM Group	Module	Memory Type	RGS/RD S	Test Pattern (Algorithm)								
				Triple slow read	Triple fast read	March 13N[cycles]	Down 1A	Pre-charge	Map column	DTXN 2A	PMOS open	
1	PBIST ROM	ROM	0/1	x	x							
2	STC ROM	ROM	13/1	x	x							
3	DCAN1	SP	1/0..2			12600	x	x	x	x	x	
4	DCAN2	SP	2/0..2			12600	x	x	x	x	x	
5	DCAN3	SP	3/0..2			6360	x	x	x	x	x	
6	ESRAM	SP, multi-strobe w/ page mode	4/21..22			266320	x	x	x	x	x	
7	MibSPI	SP	5/0..5			50160	x	x	x	x	x	
8	VIM	SP	Jun-00			4200	x	x	x	x	x	
9	MibADC	2P, sync write async read	7/0..1			8400	x	x	x	x	x	
10	DMA	2P, sync write async read	8/0..5			18960	x	x	x	x	x	
11	NHET	2P, sync write async read	9/0..11			25440	x	x	x	x	x	
12	HET TU	2P, sync write async read	10/0..5			6480	x	x	x	x	x	
13	RTP	2P, sync write async read	11/0..8			37800	x	x	x	x	x	
14	Flexray	SP	12/0..7			175040	x	x	x	x	x	
15	ESRAM	SP, multi-strobe w/ page mode	20-Apr			133160	x	x	x	x	x	

SP = Single Port RAM; 2P = Two Port RAM

PRODUCT PREVIEW

NOTE

- The March13N test algorithm is recommended for application testing.
 - The maximum PBIST test execution speed is limited to 100MHz.
 - The supply current while performing PBIST self test is different than the device operating mode current. These values can be found in the I_{cc} section of the device electrical specifications.
-

2.3 Pin Assignments

2.3.1 PGE QFP Package Pinout (144 pin)

(TOP VIEW)

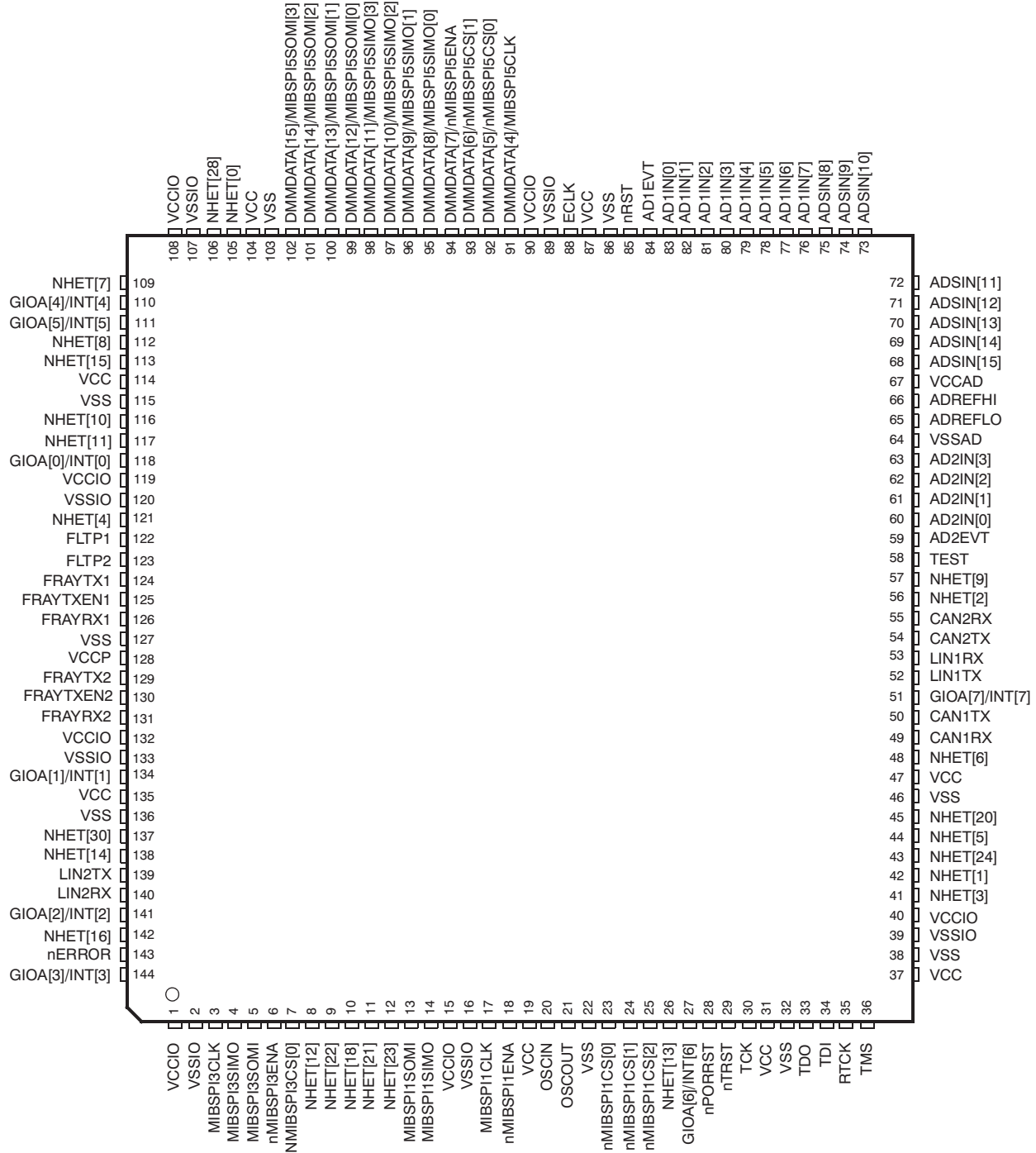



Figure 2-2. PGE Pinout (144 pin) [Top View]

PRODUCT PREVIEW

2.3.2 ZWT BGA Package Pinout (337 ball)

	A	B	C	D	E	F	G	H	J	K	L	
19	VSS	VSS	TMS	NHET [10]	MIBSPI5 CS[0]	MIBSPI1 SIMO	MIBSPI1 ENA	MIBSPI5 CLK	MIBSPI5 SIMO[0]	NHET [28]	DMM DATA[0]	19
18	VSS	TCK	TDO	TRST	NHET [08]	MIBSPI1 CLK	MIBSPI1 SOMI	MIBSPI5 ENA	MIBSPI5 SOMI[0]	NHET [0]	DMM DATA[1]	18
17	TDI	RST	EMIF_ADDR[21]	EMIF_WE	MIBSPI5 SOM[1]	DMM CLK	MIBSPI5 SIMO[3]	MIBSPI5 SIMO[2]	NHET [31]	EMIF_CS[1]	EMIF_CS[0]	17
16	RTCK	FRAY_TXEN1	EMIF_ADDR[20]	EMIF_BA[1]	MIBSPI5 SIMO[1]	DMM ENA	MIBSPI5 SOMI[3]	MIBSPI5 SOMI[2]	DMM SYNC	EMIF_DATA[0]	EMIF_DATA[1]	16
15	FRAY_RX1	FRAY_TX1	EMIF_ADDR[19]	EMIF_ADDR[18]	ETM DATA[06]	ETM DATA[05]	ETM DATA[04]	ETM DATA[03]	ETM DATA[02]	ETM DATA[16]	ETM DATA[17]	15
14	NHET [26]	ERROR	EMIF_ADDR[15]	EMIF_ADDR[16]	ETM DATA[07]	VCCIO	VCCIO	VCCIO	VCC	VCC	VCCIO	14
13	NHET [17]	NHET [19]	EMIF_ADDR[15]	EMIF_BA[0]	ETM DATA[12]	VCCIO						13
12	ECLK	NHET [04]	EMIF_ADDR[14]	EMIF_OE	ETM DATA[13]	VCCIO		VSS	VSS	VCC	VSS	12
11	NHET [14]	NHET [30]	EMIF_ADDR[13]	EMIF_DQM[1]	ETM DATA[14]	VCCIO		VSS	VSS	VSS	VSS	11
10	CAN1_TX	CAN1_RX	EMIF_ADDR[12]	EMIF_DQM[0]	ETM DATA[15]	VCC		VCC	VSS	VSS	VSS	10
	A	B	C	D	E	F	G	H	J	K	L	



PRODUCT PREVIEW

Figure 2-3. ZWT Package Pinout Top Left Quadrant (337 ball) [Top View]

	K	L	M	N	P	R	T	U	V	W	
19	NHET [28]	DMM DATA[0]	CAN3 RX	AD1 EVT	ADS IN[15]	AD2 IN[6]	AD1 IN[6]	ADS IN[11]	VSSAD	VSSAD	19
18	NHET [0]	DMM DATA[1]	CAN3 TX	NC	ADS IN[8]	ADS IN[14]	ADS IN[13]	AD1 IN[4]	AD1 IN[2]	VSSAD	18
17	EMIF_CS[1]	EMIF_CS[0]	EMIF_CS[2]	EMIF_CS[3]	NC	AD1 IN[5]	AD1 IN[3]	ADS IN[10]	AD1 IN[1]	ADS IN[9]	17
16	EMIF_DATA[0]	EMIF_DATA[1]	EMIF_DATA[2]	EMIF_DATA[3]	NC	AD2 IN[7]	ADS IN[12]	AD2 IN[3]	ADREF LO	VSSAD	16
15	ETM DATA[16]	ETM DATA [17]	ETM DATA[18]	ETM DATA[19]	NC	NC	AD2 IN[5]	AD2 IN[4]	ADREF HI	VCCAD	15
14	VCC	VCCIO	VCCIO	VCCIO	VCCIO	NC	NC	AD2 IN[2]	AD1 IN[7]	AD1 IN[0]	14
13					VCCIO	ETM DATA[1]	NC	AD2 IN[1]	AD2 IN[0]	AD2 EVT	13
12	VCC	VSS	VSS		VCCIO	ETM DATA[0]	MIBSPI5 CS[3]	RTP ENA	LIN1 TX	LIN1 RX	12
11	VSS	VSS	VSS		VCC	ETM TRACE CTL	RTP SYNC	RTP DATA[1]	RTP DATA[0]	RTP CLK	11
10	VSS	VSS	VCC		VCC	ETM TRACE CLKOUT	RTP DATA[2]	RTP DATA[3]	MIBSPI3 CS[0]	GIOB[3]	10
	K	L	M	N	P	R	T	U	V	W	

PRODUCT PREVIEW

Figure 2-4. ZWT Package Pinout Top Right Quadrant (337 ball) [Top View]



	A	B	C	D	E	F	G	H	J	K	L	
10	CAN1TX	CAN1RX	EMIF_ADDR[12]	EMIF_DQM[0]	ETM_DATA[15]	VCC		VCC	VSS	VSS	VSS	10
9	NHET [27]	FRAY_TXEN2	EMIF_ADDR[11]	EMIF_ADDR[5]	ETM_DATA[8]	VCC		VSS	VSS	VSS	VSS	9
8	FRAY_RX2	FRAY_TX2	EMIF_ADDR[10]	EMIF_ADDR[4]	ETM_DATA[9]	VCCP		VSS	VSS	VCC	VSS	8
7	LIN2_RX	LIN2_TX	EMIF_ADDR[9]	EMIF_ADDR[3]	ETM_DATA[10]	VCCIO						7
6	GIOA [4]	MIBSPI5_CS[1]	EMIF_ADDR[8]	EMIF_ADDR[2]	ETM_DATA[11]	VCCIO	VCCIO	VCCIO	VCCIO	VCC	VCC	6
5	GIOA [0]	GIOA [5]	EMIF_ADDR[7]	EMIF_ADDR[1]	ETM_DATA[20]	ETM_DATA[21]	ETM_DATA[22]	FLTP2	FLTP1	ETM_DATA[23]	ETM_DATA[24]	5
4	NHET [16]	NHET [12]	EMIF_ADDR[6]	EMIF_ADDR[0]	EMIF_DATA[4]	EMIF_DATA[5]	EMIF_DATA[6]	NHET [21]	NHET [23]	EMIF_DATA[7]	EMIF_DATA[8]	4
3	NHET [29]	NHET [22]	MIBSPI3_CS[3]	NC	NHET [11]	MIBSPI1_CS[1]	MIBSPI1_CS[2]	GIOA [6]	MIBSPI1_CS[3]	NC	NC	3
2	VSS	MIBSPI3_CS[2]	GIOA [1]	NC	NC	GIOB [2]	GIOB [5]	CAN2_TX	GIOB [6]	GIOB [1]	KELVIN_GND	2
1	VSS	VSS	GIOA [2]	NC	GIOA [3]	GIOB [7]	GIOB [4]	CAN2_RX	NHET [18]	OSCIN	OSCOUT	1
	A	B	C	D	E	F	G	H	J	K	L	

Figure 2-5. ZWT Package Pinout Bottom Left Quadrant (337 ball) [Top View]

PRODUCT PREVIEW



	K	L	M	N	P	R	T	U	V	W	
10	VSS	VSS	VCC		VCC	ETM TRACE CLKOUT	RTP DATA[2]	RTP DATA[3]	MIBSPI3 CS[0]	GIOB[3]	10
9	VSS	VSS	VSS		VCCIO	RTP DATA[4]	RTP DATA[4]	RTP DATA[5]	MIBSPI3 CLK	MIBSPI3 ENA	9
8	VCC	VSS	VSS		VCCIO	ETM DATA[31]	EMIF_DATA[15]	RTP DATA[6]	MIBSPI3 SOMI	MIBSPI3 SIMO	8
7					VCCIO	ETM DATA[30]	EMIF_DATA[14]	RTP DATA[7]	NHET [9]	$\overline{\text{PORRST}}$	7
6	VCC	VCC	VCCIO	VCCIO	VCCIO	ETM DATA[29]	EMIF_DATA[13]	RTP DATA[8]	NHET [5]	MIBSPI5 CS[2]	6
5	ETM DATA[23]	ETM DATA[24]	ETM DATA[25]	ETM DATA[26]	ETM DATA[27]	ETM DATA[28]	EMIF_DATA[12]	RTP DATA[9]	MIBSPI3 CS[1]	NHET [2]	5
4	EMIF_DATA[7]	EMIF_DATA[8]	EMIF_DATA[9]	EMIF_DATA[10]	EMIF_DATA[11]	NC	RTP DATA[11]	RTP DATA[19]	VSS	NC	4
3	NC	NC	NHET [25]	NC	NC	NC	RTP DATA[14]	RTP DATA[13]	RTP DATA[12]	NHET [6]	3
2	GIOB [1]	KELVIN GND	GIOB [0]	NHER [13]	NHET [20]	MIBSPI1 CS[0]	RTP DATA[15]	TEST	NHET [1]	VSS	2
1	OSCIN	OSCOUT	GIOA [7]	NHET [15]	NHET [24]	NC	NHET [7]	NHET [3]	VSS	VSS	1
	K	L	M	N	P	R	T	U	V	W	

Figure 2-6. ZWT Package Pinout Bottom Right Quadrant (337 ball) [Top View]

PRODUCT PREVIEW

2.4 Terminal Functions

This following table describes the pins on the device.

Table 2-8. Terminal Functions

Name	Terminal				Type	Internal pullup/pulldown	Description
	TMS570LSXXX16		TMS570LSXXX06				
	337	144	337	144			
HIGH-END TIMER (NHET)							
NHET[0]	K18	105	K18	105	3.3V I/O	2mA - z	<p>Timer input capture or output compare. The applicable NHET pins can be programmed as general-purpose input/output (GIO) pins. NHET pins are high-resolution.</p> <p>The high-resolution (HR) SHARE feature allows even HR pins to share the next higher odd HR pin structures. The next higher odd HR pin structure is always implemented, even if the next higher odd HR pad and/or pin itself is not. The HR sharing is independent of whether or not the odd pin is available externally. If an odd pin is available externally and shared, then the odd pin can only be used as a general-purpose I/O.</p> <p>NHET[0] provides SPI clock when used for SPI emulation.</p> <p>Each NHET pin is equipped with an input suppression filter that can be used to eliminate the sampling of pulses that are smaller than a programmable duration GIOA[0]/INT[0] is also connected to the NHET Pin Disable input of the NHET module.</p> <p>NHET pins can be programmed as a GIO pins when not used as NHET functional pins.</p>
NHET[1]	V2	42	V2	42			
NHET[2]	W5	56	W5	56			
NHET[3]	U1	41	U1	41			
NHET[4]	B12	121	B12	121			
NHET[5]	V6	44	V6	44			
NHET[6]	W3	48	W3	48			
NHET[7]	T1	109	T1	109			
NHET[8]	E18	112	E18	112			
NHET[9]	V7	57	V7	57			
NHET[10]	D19	116	D19	116			
NHET[11]	E3	117	E3	117			
NHET[12]	B4	8	B4	8			
NHET[13]	N2	26	N2	26			
NHET[14]	A11	138	A11	138			
NHET[15]	N1	113	N1	113			
NHET[16]	A4	142	A4	142			
NHET[17]	A13		A13				
NHET[18]	J1	10	J1	10			
NHET[19]	B13		B13				
NHET[20]	P2	45	P2	45			
NHET[21]	H4	11	H4	11			
NHET[22]	B3	9	B3	9			
NHET[23]	J4	12	J4	12			
NHET[24]	P1	43	P1	43			
NHET[25]	M3		M3				
NHET[26]	A14		A14				
NHET[27]	A9		A9				
NHET[28]	K19	106	K19	106			
NHET[29]	A3		A3				
NHET[30]	B11	137	B11	137			
NHET[31]	J17		J17				

Table 2-8. Terminal Functions (continued)

Name	Terminal				Type	Internal pullup/pulldown	Description	
	TMS570LSXXX16		TMS570LSXXX06					
	337	144	337	144				
GENERAL-PURPOSE I/O (GIO)								
GIOA[0]/INT0	A5	118	A5	118	3.3V I/O	2mA - z	Program mable IPD (20mA)	General-purpose input/output pin. GIOA[0]/INT[0] is an interrupt-capable pin. GIOA[0]/INT[0] is also connected to the NHET Pin Disable input of the NHET module.
GIOA[1]/INT1	C2	134	C2	134				
GIOA[2]/INT2	C1	141	C1	141				
GIOA[3]/INT3	E1	144	E1	144				
GIOA[4]/INT4	A6	110	A6	110				
GIOA[5]/INT5	B5	111	B5	111				
GIOA[6]/INT6	H3	27	H3	27				
GIOA[7]/INT7	M1	51	M1	51				
GIOB[0]	M2		M2					
GIOB[1]	K2		K2					
GIOB[2]	F2		F2					
GIOB[3]	W10		W10					
GIOB[4]	G1		G1					
GIOB[5]	G2		G2					
GIOB[6]	J2		J2					
GIOB[7]	F1		F1					
Flexray Controller (FLEXRAY)								
NOTE: Devices with out the FlexRay option should leave all FlexRay pins unconnected (NC)								
FRAYRX1	A15	126			3.3V I		Program mable IPD (20mA)	Flexray data receive (channel 1) pin
FRAYTX1	B15	124			3.3V O	8mA		Flexray data transmit (channel 1) pin
FRAYTXEN1	B16	125				8mA		Flexray transmit enable (channel 1) pin
FRAYRX2	A8	131			3.3V I		Program mable IPD(20mA)	Flexray data receive (channel 2) pin
FRAYTX2	B8	129			3.3V O	8mA		Flexray data transmit (channel 2) pin
FRAYTXEN2	B9	130				8mA		Flexray transmit enable (channel 2) pin
CAN Controller (DCAN1)								
CAN1TX	A10	50	A10	50	3.3V I/O	2mA - z	Program mable IPU (20mA)	CAN1 transmit pin or GIO pin
CAN1RX	B10	49	B10	49				CAN1 receive pin or GIO pin
CAN Controller (DCAN2)								
CAN2TX	H2	54	H2	54	3.3V I/O	2mA - z	Program mable IPU (20mA)	CAN2 transmit pin or GIO pin
CAN2RX	H1	55	H1	55				CAN2 receive pin or GIO pin
CAN Controller (DCAN3)								
CAN3TX	M18		M18		3.3V I/O	2mA - z	program mable IPU (20mA)	CAN3 transmit pin or GIO pin
CAN3RX	M19		M19					CAN3 receive pin or GIO pin

PRODUCT PREVIEW

Table 2-8. Terminal Functions (continued)

Name	Terminal				Type	Internal pullup/pulldown	Description	
	TMS570LSXXX16		TMS570LSXXX06					
	337	144	337	144				
Serial Communications Interface (SCI)/Local Interconnect Network (LIN1)								
LIN1RX	W12	53	W12	53	3.3V I/O	2mA - z	Program mable IPU (20mA)	LIN1 data receive pin or GIO pin
LIN1TX	V12	52	V12	52				LIN1 data transmit pin or GIO pin
Serial Communications Interface (SCI)/Local Interconnect Network (LIN2)								
LIN2RX	A7	140	A7	140	3.3V I/O	2mA - z	Program mable IPU (20mA)	LIN2 data receive pin or GIO pin
LIN2TX	B7	139	B7	139				LIN2 data transmit pin or GIO pin
Multibuffered Serial Peripheral Interface (MIBSPI1)								
MIBSPI1CLK	F18	17	F18	17	3.3V I/O	4mA	Program mable IPU (20µA)	MIBSPI1 slave chip select pins or GIO pins
MIBSPI1CS[0]	R2	23	R2	23		2mA - z		MIBSPI1 clock pin or GIO pin
MIBSPI1CS[1]	F3	24	F3	24				
MIBSPI1CS[2]	G3	25	G3	25				
MIBSPI1CS[3]	J3		J3					
MIBSPI1ENA	G19	218	G19	218		2mA - z		MIBSPI1 enable pin or GIO pin
MIBSPI1SIMO	F19	14	F19	14		4mA		MIBSPI1 data stream - Slave in/master out pin or GIO pin
MIBSPI1SOMI	G18	13	G18	13				MIBSPI1 data stream - Slave out/master in pin or GIO pin
Multibuffered Serial Peripheral Interface (MIBSPI3)								
MIBSPI3CLK	V9	3	V9	3	3.3V I/O	4mA	Program mable IPU (20mA)	MIBSPI3 slave chip select pins or GIO pins
MIBSPI3CS[0]	V10	7	V10	7		2mA - z		MIBSPI3 clock pin or GIO pin
MIBSPI3CS[1]	V5		V5					
MIBSPI3CS[2]	B2		B2					
MIBSPI3CS[3]	C3		C3					
MIBSPI3ENA	W9	6	W9	6		2mA - z		MIBSPI3 enable pin or GIO pin
MIBSPI3SIMO	W8	4	W8	4		4mA		MIBSPI3 data stream - Slave in/master out pin or GIO pin
MIBSPI3SOMI	V8	5	V8	5				MIBSPI3 data stream - Slave out/master in pin or GIO pin

Table 2-8. Terminal Functions (continued)

Name	Terminal				Type	Internal pullup/pulldown	Description
	TMS570LSXXX16		TMS570LSXXX06				
	337	144	337	144			
Multibuffered Serial Peripheral Interface - Parallel (MIBSPI5)							
MIBSPI5CLK/DMMDATA[4]	H19	91	H19	91	3.3V I/O	4mA	MIBSPI5 clock pin or GIO pin; multiplexed with DMMDATA[4] pin
MIBSPI5CS[0]/DMMDATA[5]	E19	92	E19	92		2mA - z	MIBSPI5 slave chip select pins or GIO pins; multiplexed with DMMDATA pins
MIBSPI5CS[1]/DMMDATA[6]	B6	93	B6	93			
MIBSPI5CS[2]/DMMDATA[2]	W6		W6				
MIBSPI5CS[3]/DMMDATA[3]	T12		T12				
MIBSPI5ENA/DMMDATA[7]	H18	94	H18	94			
MIBSPI5SIMO[0]/DMMDATA[8]	J19	95	J19	95	3.3V I/O	4mA	MIBSPI5 data stream - Slave in/master out pins or GIO pins; multiplexed with DMMDATA pins
DMMDATA[9]/MIBSPI5SIMO[1]	E16	96	E16	96			
MIBSPI5SIMO[2]/DMMDATA[10]	H17	97	H17	97			
MIBSPI5SIMO[3]/DMMDATA[11]	G17	98	G17	98			
MIBSPI5SOMI[0]/DMMDATA[12]	J18	99	J18	99		4mA	MIBSPI5 data stream - Slave out/master in pins or GIO pins; multiplexed with DMMDATA pins
MIBSPI5SOMI[1]/DMMDATA[13]	E17	100	E17	100			
MIBSPI5SOMI[2]/DMMDATA[14]	H16	101	H16	101			
MIBSPI5SOMI[3]/DMMDATA[15]	G16	102	G16	102			
Multibuffered Analog-To-Digital Converter (MIBADC1)							
AD1EVT	N19	84	N19	84	3.3V I/O	2 mA - z	Program mable IPD (20mA) MibADC1 event input pin or GIO pin
AD1IN[0]	W14	83	W14	83	3.3V I		MibADC1 analog input pins
AD1IN[1]	V17	82	V17	82			
AD1IN[2]	V18	81	V18	81			
AD1IN[3]	T17	80	T17	80			
AD1IN[4]	U18	79	U18	79			
AD1IN[5]	R17	78	R17	78			
AD1IN[6]	T19	77	T19	77			
AD1IN[7]	V14	76	V14	76			

PRODUCT PREVIEW

Table 2-8. Terminal Functions (continued)

Name	Terminal				Type	Internal pullup/pulldown	Description
	TMS570LSXXX16		TMS570LSXXX06				
	337	144	337	144			
Multibuffered Analog-To-Digital Converter (MIBADC2)							
AD2EVT	W13	59	W13	59	3.3V I/O	2 mA - z	Program mable IPD (20mA) MibADC2 event input pin or GIO pin
AD2IN[0]	V13	60	V13	60	3.3 V I		MibADC2 analog input pins
AD2IN[1]	U13	61	U13	61			
AD2IN[2]	U14	62	U14	62			
AD2IN[3]	U16	63	U16	63			
AD2IN[4]	U15		U15				
AD2IN[5]	T15		T15				
AD2IN[6]	R19		R19				
AD2IN[7]	R16		R16				
Multibuffered Analog-To-Digital Converter - shared signals (MIBADC1, MIBADC2)							
ADSIN[8]	P18	75	P18	75	3.3 V I		MibADC1, MibADC2 shared analog input pins
ADSIN[9]	W17	74	W17	74			
ADSIN[10]	U17	73	U17	73			
ADSIN[11]	U19	72	U19	72			
ADSIN[12]	T16	71	T16	71			
ADSIN[13]	T18	70	T18	70			
ADSIN[14]	R18	69	R18	69			
ADSIN[15]	P19	68	P19	68			
ADREFHI	V15	66	V15	66	3.3-V REF		MibADC1, MibADC2 module high-voltage reference input
ADREFLO	V16	65	V16	65	GND REF		MibADC1, MibADC2 module low-voltage reference input
VCCAD	W15	67	W15	67	3.3-V PWR		MibADC1, MibADC2 analog supply voltage
VSSAD	V19	64	V19	64	GND		MibADC1, MibADC2 analog ground reference
VSSAD	W16		W16				
VSSAD	W18		W18				
VSSAD	W19		W19				
Oscillator (OSC)							
OSCIN	K1	20	K1	20	1.5VI		Oscillator input connection pin or external clock input pin
OSCOU	L1	21	L1	21	1.5V O		Oscillator output connection pin
Kelvin_GND	L2		L2		GND		Kelvin_GND for oscillator

Table 2-8. Terminal Functions (continued)

Name	Terminal				Type	Internal pullup/pulldown	Description
	TMS570LSXXX16		TMS570LSXXX06				
	337	144	337	144			
System Module (SYS)							
$\overline{\text{PORRST}}$	W7	28	W7	28	3.3V I		Power on Reset Pin. External power supply monitor circuitry must assert a power-on reset on this pin.
$\overline{\text{RST}}$	B17	85	B17	85	3.3V I/O	4mA	Active Low Bidirectional Reset pin. An external device can assert a device reset on this pin. The output buffer on this pin is implemented as an open drain (drives low only). To ensure an external reset is not arbitrarily generated, TI recommends that an external pullup resistor is connected to this pin.
ECLK	A12	88	A12	88		8mA	IPD (20µA)
Tset/Debug (T/D)							
TCK	B18	30	B18	30	3.3V I		IPD (100mA) JTAG test clock pin. Clocks the JTAG debug logic.
RTCK	A16	35	A16	35	3.3V O	8 mA	JTAG return test clock pin. (JTAG)
TDI	A17	34	A17	34	3.3V I/O		JTAG test data in pin.
TDO	C18	33	C18	33			JTAG test data out pin.
TMS	C19	36	C19	36			JTAG serial input pin for controlling the state of the CPU test access port (TAP) controller.
TRST	D18	29	D18	29	3.3V I		IPU (100mA) JTAG test hardware reset to TAP. IEEE Standard 1149-1 (JTAG) Boundary-Scan Logic
TEST	U2	58	U2	58		Test enable pin. Reserved for internal TI use only. For proper operation, this pin must be connected to ground, e.g. using a external resistor.	
Error Signaling Module (ESM)							
$\overline{\text{ERROR}}$	B14	143	B14	143	3.3V I/O	8mA	IPD (20mA) Error Signaling pin
Flash							
FLTP1	J5	122	J5	122			Flash Test Pad 1 pin. For proper operation this pin must connect only to a test pad or not be connected at all [no connect (NC)]. The test pad must not be exposed in the final product where it might be subjected to an ESD event.
FLTP2	H5	123	H5	123			Flash Test Pad 2 pin. For proper operation this pin must connect only to a test pad or not be connected at all [no connect (NC)]. The test pad must not be exposed in the final product where it might be subjected to an ESD event.
V _{CCP}	F8	128	F8	128	3.3V PWR		Flash pump voltage supply (3.3 V). This pin is required for Flash read, program and erase operations.

PRODUCT PREVIEW

Table 2-8. Terminal Functions (continued)

Terminal					Type	Internal pullup/pulldown	Description
Name	TMS570LSXXX16		TMS570LSXXX06				
	337	144	337	144			
RAM Trace Port Module (RTP)							
RTPDATA[0]	V11		V11		3.3V I/O	8mA	Program mable IPU (20mA) RAM Trace Port Output Data Signal pins or GIO pins
RTPDATA[1]	U11		U11				
RTPDATA[2]	T10		T10				
RTPDATA[3]	U10		U10				
RTPDATA[4]	T9		T9				
RTPDATA[5]	U9		U9				
RTPDATA[6]	U8		U8				
RTPDATA[7]	U7		U7				
RTPDATA[8]	U6		U6				
RTPDATA[9]	U5		U5				
RTPDATA[10]	U4		U4				
RTPDATA[11]	T4		T4				
RTPDATA[12]	V3		V3				
RTPDATA[13]	U3		U3				
RTPDATA[14]	T3		T3				
RTPDATA[15]	T2		T2				
$\overline{\text{RTPENA}}$	U12		U12		2mA - z	Packet Handshake Signal pin or GIO pin	
RTPSYNC	T11		T11		8mA	Packet Synchronization Signal pin or GIO pin	
RTPCLK	W11		W11			Packet Clock Signal pin or GIO pin	

PRODUCT PREVIEW

Table 2-8. Terminal Functions (continued)

Name	Terminal				Type	Internal pullup/pulldown	Description
	TMS570LSXXX16		TMS570LSXXX06				
	337	144	337	144			
Data Modification Module (DMM)							
DMMDATA[0]	L19		L19		3.3V I/O	Program mable IPU (20mA)	DMM Data pins or GIO pins; multiplexed with MIBSPI5 pins
DMMDATA[1]	L18		L18				
DMMDATA[2]/MIBSPI5CS[2]	W6		W6	2mA - z			
DMMDATA[3]/MIBSPI5CS[3]	T12		T12				
DMMDATA[4]/MIBSPI5CLK	H19		H19	4mA			
DMMDATA[5]/MIBSPI5CS[0]	E19		E19				
DMMDATA[6]/MIBSPI5CS[1]	B6		B6	2mA - z			
DMMDATA[7]/MIBSPI5ENA	H18		H18				
DMMDATA[8]/MIBSPI5SIMO[0]	J19		J19				
DMMDATA[9]/MIBSPI5SIMO[1]	E16		E16				
DMMDATA[10]/MIBSPI5SIMO[2]	H17		H17				
DMMDATA[11]/MIBSPI5SIMO[3]	G17		G17	4mA			
DMMDATA[12]/MIBSPI5SOMI[0]	J18		J18				
DMMDATA[13]/MIBSPI5SOMI[1]	E17		E17				
DMMDATA[14]/MIBSPI5SOMI[2]	H16		H16				
DMMDATA[15]/MIBSPI5SOMI[3]	G16		G16				
DMMENA	F16		F16	8mA		DMM Handshake pin or GIO pin	
DMMSYNC	J16		J16			DMM Synchronization pin or GIO pin	
DMMCLK	F17		F17	2mA - z		DMM Clock input pin or GIO pin	

PRODUCT PREVIEW

Table 2-8. Terminal Functions (continued)

Name	Terminal				Type	Internal pullup/pulldown	Description
	TMS570LSXXX16		TMS570LSXXX06				
	337	144	337	144			
External Memory Interface Module (EMIF)							
EMIFBADD[0]	D13		D13		3.3V I/O	8mA	EMIF Byte Address pins
EMIFBADD[1]	D16		D16				
EMIFDATA[0]	K16		K16		3.3V I/O	8mA	Program mable IPU (20mA) EMIF Data pins
EMIFDATA[1]	L16		L16				
EMIFDATA[2]	M16		M16				
EMIFDATA[3]	N16		N16				
EMIFDATA[4]	E4		E4				
EMIFDATA[5]	F4		F4				
EMIFDATA[6]	G4		G4				
EMIFDATA[7]	K4		K4				
EMIFDATA[8]	L4		L4				
EMIFDATA[9]	M4		M4				
EMIFDATA[10]	N4		N4				
EMIFDATA[11]	P4		P4				
EMIFDATA[12]	T5		T5				
EMIFDATA[13]	T6		T6				
EMIFDATA[14]	T7		T7				
EMIFDATA[15]	T8		T8				
EMIFADD[0]	D4		D4		3.3V I/O	8mA	EMIF Address pins
EMIFADD[1]	D5		D5				
EMIFADD[2]	D6		D6				
EMIFADD[3]	D7		D7				
EMIFADD[4]	D8		D8				
EMIFADD[5]	D9		D9				
EMIFADD[6]	C4		C4				
EMIFADD[7]	C5		C5				
EMIFADD[8]	C6		C6				
EMIFADD[9]	C7		C7				
EMIFADD[10]	C8		C8				
EMIFADD[11]	C9		C9				
EMIFADD[12]	C10		C10				
EMIFADD[13]	C11		C11				
EMIFADD[14]	C12		C12				
EMIFADD[15]	C13		C13				
EMIFADD[16]	D14		D14				
EMIFADD[17]	C14		C14				
EMIFADD[18]	D15		D15				
EMIFADD[19]	C15		C15				
EMIFADD[20]	C16		C16				
EMIFADD[21]	C17		C17				
EMIFCS[0]	L17		L17		3.3V I/O	8mA	EMIF Chip Select pins
EMIFCS[1]	K17		K17				
EMIFCS[2]	M17		M17				
EMIFCS[3]	N17		N17				

Table 2-8. Terminal Functions (continued)

Name	Terminal				Type		Internal pullup/pulldown	Description
	TMS570LSXXX16		TMS570LSXXX06					
	337	144	337	144				
EMIFWE	D17		D17		3.3V I/O	8mA		EMIF Write Enable pin
EMIFOE	D12		D12		3.3V I/O	8mA		EMIF Output Enable pin
EMIFDQM[0]	D10		D10		3.3V I/O	8mA		EMIF Byte Enable pins
EMIFDQM[1]	D11		D11					

PRODUCT PREVIEW

Table 2-8. Terminal Functions (continued)

Name	Terminal				Type	Internal pullup/pulldown	Description
	TMS570LSXXX16		TMS570LSXXX06				
	337	144	337	144			
Embedded Trace Module (ETM)							
ETMDATA[0]	R12		R12		3.3V O	8mA	ETM Trace Data output pins
ETMDATA[1]	R13		R13				
ETMDATA[2]	J15		J15				
ETMDATA[3]	H15		H15				
ETMDATA[4]	G15		G15				
ETMDATA[5]	F15		F15				
ETMDATA[6]	E15		E15				
ETMDATA[7]	E14		E14				
ETMDATA[8]	E9		E9				
ETMDATA[9]	E8		E8				
ETMDATA[10]	E7		E7				
ETMDATA[11]	E6		E6				
ETMDATA[12]	E13		E13				
ETMDATA[13]	E12		E12				
ETMDATA[14]	E11		E11				
ETMDATA[15]	E10		E10				
ETMDATA[16]	K15		K15				
ETMDATA[17]	L15		L15				
ETMDATA[18]	M15		M15				
ETMDATA[19]	N15		N15				
ETMDATA[20]	E5		E5				
ETMDATA[21]	F5		F5				
ETMDATA[22]	G5		G5				
ETMDATA[23]	K5		K5				
ETMDATA[24]	L5		L5				
ETMDATA[25]	M5		M5				
ETMDATA[26]	N5		N5				
ETMDATA[27]	P5		P5				
ETMDATA[28]	R5		R5				
ETMDATA[29]	R6		R6				
ETMDATA[30]	R7		R7				
ETMDATA[31]	R8		R8				
ETMTRACECTL	R11		R11		3.3V O	8mA	ETM Control pin
ETMTRACECLKOUT	R10		R10		3.3V O	8mA	ETM Clock output pin
ETMTRACECLKIN	R9		R9		3.3V I	IPU (20mA)	ETM Clock input pin

PRODUCT PREVIEW

Table 2-8. Terminal Functions (continued)

Name	Terminal				Type	Internal pullup/pulldown	Description			
	TMS570LSXXX16		TMS570LSXXX06							
	337	144	337	144						
Supply Voltage Digital I/O (3.3V) and Core (1.5V)										
V _{CCIO}	F6	1	F6	1	3.3V PWR		Digital I/O supply pins Note: All V _{CCIO} pads are connected to the BGA packages through the package substrate. There is not a direct ball to bond pad connection for this supply.			
V _{CCIO}	F7	15	F7	15						
V _{CCIO}	F11	40	F11	40						
V _{CCIO}	F12	90	F12	90						
V _{CCIO}	F13	108	F13	108						
V _{CCIO}	F14	119	F14	119						
V _{CCIO}	G6	132	G6	132						
V _{CCIO}	G14		G14							
V _{CCIO}	H6		H6							
V _{CCIO}	H14		H14							
V _{CCIO}	J6		J6							
V _{CCIO}	L14		L14							
V _{CCIO}	M6		M6							
V _{CCIO}	M14		M14							
V _{CCIO}	N6		N6							
V _{CCIO}	N14		N14							
V _{CCIO}	P6		P6							
V _{CCIO}	P7		P7							
V _{CCIO}	P8		P8							
V _{CCIO}	P9		P9							
V _{CCIO}	P12		P12							
V _{CCIO}	P13		P13							
V _{CCIO}	P14		P14							
V _{CCIO}										
V _{CC}	F9	19	F9	19	1.5V PWR		Digital Core supply pins Note: All V _{CC} pads are connected to the BGA packages through the package substrate. There is not a direct ball to bond pad connection for this supply.			
V _{CC}	F10	31	F10	31						
V _{CC}	H10	37	H10	37						
V _{CC}	J14	47	J14	47						
V _{CC}	K6	87	K6	87						
V _{CC}	K8	104	K8	104						
V _{CC}	K12	114	K12	114						
V _{CC}	K14	135	K14	135						
V _{CC}	L6		L6							
V _{CC}	M10		M10							
V _{CC}	P10		P10							
V _{CC}	P11		P11							
V _{CC}										

PRODUCT PREVIEW

Table 2-8. Terminal Functions (continued)

Terminal					Type	Internal pullup/pulldown	Description
Name	TMS570LSXXX16		TMS570LSXXX06				
	337	144	337	144			
Supply Ground							
V _{SS}	A1	2	A1	2	GND		Digital supply ground reference pins Note: All V _{SS} pads are connected to the BGA packages through the package substrate.
V _{SS}	A2	16	A2	16			
V _{SS}	A18	22	A18	22			
V _{SS}	A19	32	A19	32			
V _{SS}	B1	38	B1	38			
V _{SS}	B19	39	B19	39			
V _{SS}	H8	46	H8	46			
V _{SS}	H9	86	H9	86			
V _{SS}	H11	89	H11	89			
V _{SS}	H12	103	H12	103			
V _{SS}	J8	107	J8	107			
V _{SS}	J9	115	J9	115			
V _{SS}	J10	120	J10	120			
V _{SS}	J11	127	J11	127			
V _{SS}	J12	133	J12	133			
V _{SS}	K9	136	K9	136			
V _{SS}	K10		K10				
V _{SS}	K11		K11				
V _{SS}	L8		L8				
V _{SS}	L9		L9				
V _{SS}	L10		L10				
V _{SS}	L11		L11				
V _{SS}	L12		L12				
V _{SS}	M8		M8				
V _{SS}	M9		M9				
V _{SS}	M11		M11				
V _{SS}	M12		M12				
V _{SS}	V1		V1				
V _{SS}	W1		W1				
V _{SS}	W2		W2				
V _{SS}	V4		V4				
V _{SS}							
V _{SS}							
V _{SS}							
V _{SS}							
V _{SS}							

PRODUCT PREVIEW

2.5 Device Support

2.5.1 Device and Development-Support Tool Nomenclature

To designate the stages in the product development cycle, TI assigns prefixes to the part numbers of all devices and support tools. Each commercial family member has one of three prefixes: TMX, TMP, or TMS (e.g., TMS570LS20216ASPGEQQ1). Texas Instruments recommends two of three possible prefix designators for its support tools: TMDX and TMDS. These prefixes represent evolutionary stages of product development from engineering prototypes (TMX/TMDX) through fully qualified production devices/tools (TMS/TMDS).

Device development evolutionary flow:

- TMX** Experimental device that is not necessarily representative of the final device's electrical specifications.
- TMP** Final silicon die that conforms to the device's electrical specifications but has not completed quality and reliability verification.
- TMS** Fully-qualified production device.

Support tool development evolutionary flow:

- TMDX** Development-support product that has not yet completed Texas Instruments internal qualification testing.
- TMDS** Fully qualified development-support product.

TMX and TMP devices and TMDX development-support tools are shipped against the following disclaimer:

"Developmental product is intended for internal evaluation purposes."

TMS devices and TMDS development-support tools have been characterized fully, and the quality and reliability of the device have been demonstrated fully. TI's standard warranty applies.

Predictions show that prototype devices (TMX or TMP) have a greater failure rate than the standard production devices. Texas Instruments recommends that these devices not be used in any production system because their expected end-use failure rate still is undefined. Only qualified production devices are to be used.

TI device nomenclature also includes a suffix with the device family name. This suffix indicates the package type (for example, PGE), the temperature range (for example, "Blank" is the commercial temperature range), and the device speed range in megahertz.

Full Part #	TMS	570	LS	20	2	16	A	S	PGE	Q	Q1	R
Orderable Part #	S	5	LS	20	2	16	A	S	PGE	Q	Q1	R

Prefix: TM
 S = Fully TMS Qualified
 P = TMP Prototype
 X = TMX Samples

Core Technology:
 5 = 570 Cortex R4

Architecture:
 LS = Lockstep CPUs

Flash Memory Size:
 20 = 2MB
 10 = 1MB

RAM Memory Size:
 2 = 160kB
 1 = 128kB

Peripheral Set:
 16 = Flexray
 06 = No Flexray

Die Revision:
 Blank = Initial Die
 A = 1st Die Revision
 B = 2nd Die Revision

Technology/Core Voltage:
 S = F035 (130nm), 1.5 V nominal core voltage

Package Type:
 PGE = 144p QFP Package [Green]
 ZWT = 337p BGA Package [Green]

Temperature Range:
 I = -40...+85°C
 T = -40...+105°C
 Q = -40...+125°C

Quality Designator:
 Q1 = Automotive

Shipping Options:
 R = Tape and Reel

PRODUCT PREVIEW

A. For actual device part numbers (P/Ns) and ordering information, see the TI website (<http://www.ti.com>).

Figure 2-7. Device Numbering Conventions^(A)

3 Reset / Abort Sources

3.1 Reset / Abort Sources

The device Resets and Aborts are handled as shown in the following table. The table shows the source of the error, the system mode, the type of error response and the corresponding Error Signaling Module (ESM) channel. Only standard ARM exception handlers and ESM errors are used.

Table 3-1. Reset / Abort Sources

Error Source	System Mode	Error Response	ESM Hookup group channel
1) CPU transactions			
Precise write error (Strongly Ordered)	User/Privilege	Precise Abort (CPU)	n/a
Precise read error (Device or Normal)	User/Privilege	Precise Abort (CPU)	n/a
Imprecise write error (Device or Normal)	User/Privilege	Imprecise Abort (CPU)	n/a
Illegal instruction	User/Privilege	Undefined Instruction Trap (CPU) ⁽¹⁾	n/a
MPU access violation	User/Privilege	Abort (CPU)	n/a
2) SRAM			
B0 Tightly Coupled Memory (TCM) (even) ECC single error (correctable)	User/Privilege	ESM	1.26
B0 TCM (even) ECC double error (non-correctable)	User/Privilege	Abort (CPU), ESM => nERROR	
ESM => nERROR	3.3		
B0 TCM (even) uncorrectable error (i.e. redundant address decode)	User/Privilege	ESM => NMI	2.6
B0 TCM (even) address bus parity error	User/Privilege	ESM => NMI	2.1
B1 TCM (odd) ECC single error (correctable)	User/Privilege	ESM	1.28
B1 TCM (odd) ECC double error (non-correctable)	User/Privilege	Abort (CPU), ESM => nERROR	
ESM => nERROR	3.5		
B1 TCM (odd) uncorrectable error (i.e. redundant address decode)	User/Privilege	ESM => NMI	2.8
B1 TCM (odd) address bus parity error	User/Privilege	ESM => NMI	2.12
3) Flash with ECC INTEGRATED INTO CPU			
ECC single error (correctable)	User/Privilege	ESM	1.6
ECC double error (non-correctable)	User/Privilege	Abort (CPU), ESM => nERROR	
ESM => nERROR	3.7		
Uncorrectable error (i.e. redundant address tag, redundant syndrome			
compare, address bus parity, etc.)	User/Privilege	ESM => NMI	2.4
4) DMA transactions			

(1) The Undefined Instruction TRAP is NOT detectable outside the CPU. The trap is taken only if the Code reaches the execute stage of the CPU.

Table 3-1. Reset / Abort Sources (continued)

Error Source	System Mode	Error Response	ESM Hookup group channel
External imprecise error on read (Illegal transaction with ok response)	User/Privilege	ESM	1.5
External imprecise error on write (Illegal transaction with ok response)	User/Privilege	ESM	1.13
Memory access permission violation	User/Privilege	ESM	1.2
Memory parity error	User/Privilege	ESM	1.3
5) DMM transactions			
External imprecise error on read (Illegal transaction with ok response)	User/Privilege	ESM	1.5
External imprecise error on write (Illegal transaction with ok response)	User/Privilege	ESM	1.13
6) AHB-AP transactions			
External imprecise error on read (Illegal transaction with ok response)	User/Privilege	ESM	1.5
External imprecise error on write (Illegal transaction with ok response)	User/Privilege	ESM	1.13
7) HET TU			
NCNB (Strongly Ordered) transaction with slave error response	User/Privilege	Interrupt => VIM	n/a
External imprecise error (Illegal transaction with ok response)	User/Privilege	Interrupt => VIM	n/a
Memory access permission violation	User/Privilege	ESM	1.9
Memory parity error	User/Privilege	ESM	1.8
8) NHET			
Memory parity error	User/Privilege	ESM	1.7
9) MibSPI			
MibSPI1 memory parity error	User/Privilege	ESM	1.17
MibSPI3 memory parity error	User/Privilege	ESM	1.18
MibSPI5 memory parity error	User/Privilege	ESM	1.24
10) MibADC			
MibADC1 memory parity error	User/Privilege	ESM	1.19
MibADC2 memory parity error	User/Privilege	ESM	1.1
11) DCAN			
DCAN1 memory parity error	User/Privilege	ESM	1.21
DCAN2 memory parity error	User/Privilege	ESM	1.23
DCAN3 memory parity error	User/Privilege	ESM	1.22
12) PLL			
PLL slip error	User/Privilege	ESM	1.1
13) Clock monitor			
Clock monitor interrupt	User/Privilege	ESM	1.11
14) CCM			
Self test failure	User/Privilege	ESM	1.31
Compare failure	User/Privilege	ESM => NMI	2.2

Table 3-1. Reset / Abort Sources (continued)

Error Source	System Mode	Error Response	ESM Hookup group channel
15) Flexray			
Memory parity error	User/Privilege	ESM	1.12
16) Flexray TU			
NCNB (Strongly Ordered) transaction with slave error response	User/Privilege	Interrupt => VIM	n/a
External imprecise error (Illegal transaction with ok response)	User/Privilege	Interrupt => VIM	n/a
Memory access permission violation	User/Privilege	ESM	1.16
Memory parity error	User/Privilege	ESM	1.14
17) VIM			
Memory parity error	User/Privilege	ESM	1.15
18) voltage monitor			
VMON out of voltage range	n/a	Reset	n/a
19) CPU Selftest (LBIST)			
CPU Selftest (LBIST) error	User/Privilege	ESM	1.27
20) errors reflected in the SYSESR register			
Power-Up Reset; VCC out of voltage range	n/a	Reset	n/a
Oscillator fail / PLL slip ⁽²⁾	n/a	Reset	n/a
Watchdog time limit exceeded	n/a	Reset	n/a
CPU Reset	n/a	Reset	n/a
Software Reset	n/a	Reset	n/a
External Reset	n/a	Reset	n/a

(2) Oscillator fail/PLL slip can be configured in the system register PLLCTL1 to generate a reset.

PRODUCT PREVIEW

4 Peripherals

4.1 Error Signaling Module (ESM)

The Error Signaling Module (ESM) is used to indicate a severe device failure via interrupts and the external ERROR pin. The error pin is normally used by an external device to either reset the controller and/or keep the system in a fail safe state.

The ESM module consists of three error groups with 32 inputs each. The generation of the interrupts and the activation of the ERROR Pin is shown in the following table. The next table shows the ESM error sources and their corresponding group and channel numbers.

Table 4-1. ESM Groups

Error Group	Interrupt, Level	Influence on Error pin
Group1	maskable, low/high	configurable
Group2	non-maskable, high	fixed
Group3	none, none	fixed

Table 4-2. ESM Assignments

ERROR Sources	Group	Channels
Reserved	Group1	0
MibADC2 - parity	Group1	1
DMA - MPU	Group1	2
DMA - parity	Group1	3
Reserved	Group1	4
DMA/DMM/AHB-AP - imprecise read error	Group1	5
Flash (ATCM) - correctable error	Group1	6
NHET - parity	Group1	7
HET TU - parity	Group1	8
HET TU - MPU	Group1	9
PLL - slip	Group1	10
Clock Monitor - interrupt	Group1	11
Flexray - parity	Group1	12
DMA/DMM/AHB-AP - imprecise write error	Group1	13
Flexray TU - parity	Group1	14
VIM RAM - parity	Group1	15
Flexray TU - MPU	Group1	16
MibSPI1 - parity	Group1	17
MibSPI3 - parity	Group1	18
MibADC1 - parity	Group1	19
Reserved	Group1	20
DCAN1 - parity	Group1	21
DCAN3 - parity	Group1	22
DCAN2 - parity	Group1	23
MibSPI5 - parity	Group1	24
Reserved	Group1	25
RAM even bank (B0TCM) - correctable error	Group1	26
CPU - selftest	Group1	27
RAM odd bank (B1TCM) - correctable error	Group1	28
Reserved	Group1	29

Table 4-2. ESM Assignments (continued)

ERROR Sources	Group	Channels
Reserved	Group1	30
CCM-R4 - selftest	Group1	31
Reserved	Group2	0
Reserved	Group2	1
CCM-R4 - compare	Group2	2
Reserved	Group2	3
Flash (ATCM) - uncorrectable error	Group2	4
Reserved	Group2	5
RAM even bank (B0TCM) - uncorrectable error	Group2	6
Reserved	Group2	7
RAM odd bank (B1TCM) - uncorrectable error	Group2	8
Reserved	Group2	9
RAM even bank (B0TCM) - address bus parity error	Group2	10
Reserved	Group2	11
RAM odd bank (B1TCM) - address bus parity error	Group2	12
Reserved	Group2	13
Reserved	Group2	14
Reserved	Group2	15
Flash (ATCM) - ECC live lock detect	Group2	16
Reserved	Group2	17
Reserved	Group2	18
Reserved	Group2	19
Reserved	Group2	20
Reserved	Group2	21
Reserved	Group2	22
Reserved	Group2	23
Reserved	Group2	24
Reserved	Group2	25
Reserved	Group2	26
Reserved	Group2	27
Reserved	Group2	28
Reserved	Group2	29
Reserved	Group2	30
Reserved	Group2	31
Reserved	Group3	0
Reserved	Group3	1
Reserved	Group3	2
RAM even bank (B0TCM) - ECC uncorrectable error	Group3	3
Reserved	Group3	4
RAM odd bank (B1TCM) - ECC uncorrectable error	Group3	5
Reserved	Group3	6
Flash (ATCM) - ECC uncorrectable error	Group3	7
Reserved	Group3	8
Reserved	Group3	9
Reserved	Group3	10
Reserved	Group3	11
Reserved	Group3	12

PRODUCT PREVIEW

Table 4-2. ESM Assignments (continued)

ERROR Sources	Group	Channels
Reserved	Group3	13
Reserved	Group3	14
Reserved	Group3	15
Reserved	Group3	16
Reserved	Group3	17
Reserved	Group3	18
Reserved	Group3	19
Reserved	Group3	20
Reserved	Group3	21
Reserved	Group3	22
Reserved	Group3	23
Reserved	Group3	24
Reserved	Group3	25
Reserved	Group3	26
Reserved	Group3	27
Reserved	Group3	28
Reserved	Group3	29
Reserved	Group3	30
Reserved	Group3	31

PRODUCT PREVIEW

4.2 Direct Memory Access (DMA)

The direct-memory access (DMA) controller transfers data to and from any specified location in the device memory map. The DMA supports data transfer for both on-chip memories and peripherals.

The DMA controller on this device supports 16 channels and 32 request lines. Each of the 32 DMA requests are assigned by default to one of the 32 available channels. For DMA requests multiplexed between multiple sources, the DMA controller cannot differentiate between the multiple sources and the user has to ensure that multiple sources are not enabled at the same time. Please refer to the DMA Specification in the TRM for more details.

The DMA request configuration is shown in the following table.

Table 4-3. DMA Request Line Connection

Modules	DMA Request Sources	DMA Request
MIBSPI1	MIBSPI1[1] ⁽¹⁾	DMAREQ[0]
MIBSPI1	MIBSPI1[0] ⁽²⁾	DMAREQ[1]
Reserved	Reserved	DMAREQ[2]
Reserved	Reserved	DMAREQ[3]
MIBSPI1 / MIBSPI3 / DCAN2	MIBSPI1[2] / MIBSPI3[2] / DCAN2 IF3	DMAREQ[4]
MIBSPI1 / MIBSPI3 / DCAN2	MIBSPI1[3] / MIBSPI3[3] / DCAN2 IF2	DMAREQ[5]
MIBSPIP5 / DCAN1	MIBSPIP5[2] / DCAN1 IF2	DMAREQ[6]
MIBADC1 / MIBSPIP5	MIBADC1 event / MIBSPIP5[3]	DMAREQ[7]
MIBSPI1 / MIBSPI3 / DCAN1	MIBSPI1[4] / MIBSPI3[4] / DCAN1 IF1	DMAREQ[8]
MIBSPI1 / MIBSPI3 / DCAN2	MIBSPI1[5] / MIBSPI3[5] / DCAN2 IF1	DMAREQ[9]
MIBADC1 / MIBSPIP5	MIBADC1 G1 / MIBSPIP5[4]	DMAREQ[10]
MIBADC1 / MIBSPIP5	MIBADC1 G2 / MIBSPIP5[5]	DMAREQ[11]
RTI / MIBSPI1 / MIBSPI3	RTI DMAREQ0 / MIBSPI1[6] / MIBSPI3[6]	DMAREQ[12]
RTI / MIBSPI1 / MIBSPI3	RTI DMAREQ1 / MIBSPI1[7] / MIBSPI3[7]	DMAREQ[13]
MIBADC2 / MIBSPI3 / MIBSPIP5	MIBADC2 event / MIBSPI3[1]* / MIBSPIP5[6]	DMAREQ[14]
MIBSPI3 / MIBSPIP5	MIBSPI3[0]† / MIBSPIP5[7]	DMAREQ[15]
MIBADC2 / MIBSPI1 / MIBSPI3 / DCAN1	MIBADC2 G1 / MIBSPI1[8] / MIBSPI3[8] / DCAN1 IF3	DMAREQ[16]
MIBADC2 / MIBSPI1 / MIBSPI3 / DCAN3	MIBADC2 G2 / MIBSPI1[9] / MIBSPI3[9] / DCAN3 IF1	DMAREQ[17]
RTI / MIBSPIP5	RTI DMAREQ2 / MIBSPIP5[8]	DMAREQ[18]
RTI / MIBSPIP5	RTI DMAREQ3 / MIBSPIP5[9]	DMAREQ[19]
LIN2 / NHET / DCAN3	LIN2 receive / NHET DMAREQ[4] / DCAN3 IF2	DMAREQ[20]
LIN2 / NHET / DCAN3	LIN2 transmit / NHET DMAREQ[5] / DCAN3 IF3	DMAREQ[21]
MIBSPI1 / MIBSPI3 / MIBSPIP5	MIBSPI1[10] / MIBSPI3[10] / MIBSPIP5[10]	DMAREQ[22]
MIBSPI1 / MIBSPI3 / MIBSPIP5	MIBSPI1[11] / MIBSPI3[11] / MIBSPIP5[11]	DMAREQ[23]
NHET / MIBSPIP5	NHET DMAREQ[6] / MIBSPIP5[12]	DMAREQ[24]
NHET / MIBSPIP5	NHET DMAREQ[7] / MIBSPIP5[13]	DMAREQ[25]
CRC / MIBSPI1 / MIBSPI3	CRC DMAREQ[0] / MIBSPI1[12] / MIBSPI3[12]	DMAREQ[26]
CRC / MIBSPI1 / MIBSPI3	CRC DMAREQ[1] / MIBSPI1[13] / MIBSPI3[13]	DMAREQ[27]
LIN1 / MIBSPIP5	LIN1 receive / MIBSPIP5[14]	DMAREQ[28]
LIN1 / MIBSPIP5	LIN1 transmit / MIBSPIP5[15]	DMAREQ[29]
MIBSPI1 / MIBSPI3 / MIBSPIP5	MIBSPI1[14] / MIBSPI3[14] / MIBSPIP5[1]*	DMAREQ[30]
MIBSPI1 / MIBSPI3 / MIBSPIP5	MIBSPI1[15] / MIBSPI3[15] / MIBSPIP5[0]†	DMAREQ[31]

(1) SPI1, SPI3, SPI5 receive in standard SPI/compatibility mode

(2) SPI1, SPI3, SPI5 transmit in standard SPI/compatibility mode

4.3 High End Timer Transfer Unit (HET-TU)

The High End Timer Transfer Unit (HET-TU) is a local Direct Memory Access (DMA) module. It is specifically designed to transfer High End Timer (NHET) data to (or from) the CPU data SRAM . The HET software controls which HET instructions generate transfer requests to the transfer unit. More information about the NHET and the HET-TU can be found in the technical reference manual (TRM). The HET-TU supports 8 channels.

The HET-TU request assignment is shown in the following table.

Table 4-4. NHET Request Line Connection

Modules	Request Source	HET TRANSFER UNIT Request
NHET	HTUREQ[0]	HET TU DCP[0]
NHET	HTUREQ[1]	HET TU DCP[1]
NHET	HTUREQ[2]	HET TU DCP[2]
NHET	HTUREQ[3]	HET TU DCP[3]
NHET	HTUREQ[4]	HET TU DCP[4]
NHET	HTUREQ[5]	HET TU DCP[5]
NHET	HTUREQ[6]	HET TU DCP[6]
NHET	HTUREQ[7]	HET TU DCP[7]

4.4 Vectored Interrupt Manager (VIM)

The Vectored Interrupt Manager (VIM) provides hardware assistance for prioritizing and controlling the many interrupt sources present on the device. Interrupt requests originating from the device modules (i.e., SPI, LIN, SCI, etc.) are assigned to channels within the 64-channel VIM. Programming multiple interrupt sources to the same VIM channel effectively shares the VIM channel between sources. The VIM request channels are maskable so that individual channels can be selectively disabled. All interrupt requests can be programmed in the VIM to be of either type:

- Fast interrupt request (FIQ)
- Normal interrupt request (IRQ)
- Non maskable interrupt (NMI) - Programmable via CPU CP15 register setting

The VIM prioritizes interrupts, whose precedence of request channels decrease with ascending channel order in the VIM (0 [highest] and 64[lowest] priority). For VIM default mapping, channel priorities, and their associated modules see the table below. More information on the VIM can be found in the technical reference manual (TRM).

Table 4-5. Interrupt Request Assignments

Modules	Interrupt Sources	Default VIM Interrupt Request
ESM	ESM High level interrupt (NMI)	0
Reserved	(NMI)	1
RTI	RTI compare interrupt 0	2
RTI	RTI compare interrupt 1	3
RTI	RTI compare interrupt 2	4
RTI	RTI compare interrupt 3	5
RTI	RTI overflow interrupt 0	6
RTI	RTI overflow interrupt 1	7
RTI	RTI timebase	8
GIO	GIO interrupt A	9
NHET	NHET level 1 interrupt	10
HET TU	HET TU level 1 interrupt	11
MIBSPI1	MIBSPI1 level 0 interrupt	12
LIN1 (incl. SCI)	LIN1 level 0 interrupt	13
MIBADC1	MIBADC1 event group interrupt	14
MIBADC1	MIBADC1 sw group 1 interrupt	15
DCAN1	DCAN1 level 0 interrupt	16
Reserved	Reserved	17
Flexray	Flexray level 0 interrupt	18
CRC	CRC Interrupt	19
ESM	ESM Low level interrupt	20
SYSTEM	Software interrupt (SSI)	21
CPU	PMU Interrupt	22
GIO	GIO interrupt B	23
NHET	NHET level 2 interrupt	24
HET TU	HET TU level 2 interrupt	25
MIBSPI1	MIBSPI1 level 1 interrupt	26
LIN1 (incl. SCI)	LIN1 level 1 interrupt	27
MIBADC1	MIBADC1 sw group 2 interrupt	28
DCAN1	DCAN1 level 1 interrupt	29
Reserved	Reserved	30
MIBADC1	MIBADC1 magnitude interrupt	31

Table 4-5. Interrupt Request Assignments (continued)

Modules	Interrupt Sources	Default VIM Interrupt Request
Flexray	Flexray level 1 interrupt	32
DMA	FTCA interrupt	33
DMA	LFSA interrupt	34
DCAN2	DCAN2 level 0 interrupt	35
DMM	DMM level 0 interrupt	36
MIBSPI3	MIBSPI3 level 0 interrupt	37
MIBSPI3	MIBSPI3 level 1 interrupt	38
DMA	HBCA interrupt	39
DMA	BTCA interrupt	40
Reserved	Reserved	41
DCAN2	DCAN2 level 1 interrupt	42
DMM	DMM level 1 interrupt	43
DCAN1	DCAN1 IF3 interrupt	44
DCAN3	DCAN3 level 0 interrupt	45
DCAN2	DCAN2 IF3 interrupt	46
FPU	FPU interrupt	47
Flexray TU	Flexray TU Transfer Status interrupt	48
LIN2 (incl. SCI)	LIN2 level 0 interrupt	49
MIBADC2	MIBADC2 event group interrupt	50
MIBADC2	MIBADC2 sw group 1 interrupt	51
Flexray	Flexray T0C interrupt	52
MIBSPIP5	MIBSPIP5 level 0 interrupt	53
LIN2 (incl. SCI)	LIN2 level 1 interrupt	54
DCAN3	DCAN3 level 1 interrupt	55
MIBSPIP5	MIBSPIP5 level 1 interrupt	56
MIBADC2	MIBADC2 sw group 2 interrupt	57
Flexray TU	Flexray TU Error interrupt	58
MIBADC2	MIBADC2 magnitude interrupt	59
DCAN3	DCAN3 IF3 interrupt	60
Reserved	Reserved	61
Flexray	Flexray T1C interrupt	62
Reserved	Reserved	63

Address location 0x00000000 in the VIM RAM is reserved for the phantom interrupt ISR entry.

4.5 MIBADC Event Trigger Sources

All three conversion groups can be configured for event-triggered operation, providing up to three event triggered groups.

The trigger source and polarity can be selected individually for group 1, group 2 and the event group from the options identified in the first table following for MibADC1 and in the second table following for MibADC2.

Table 4-6. MIBADC1 Event Trigger Sources

Event #	SOURCE SELECT BITS for G1, G2 or EVENT (G1SRC[2:0], G2SRC[2:0] or EVSRC[2:0])	Hookup
1	0	AD1EVT
2	1	NHET[8]
3	10	NHET[10]
4	11	RTI compare 0
5	100	NHET[17]
6	101	NHET[19]
7	110	GIOB[0]
8	111	GIOB[1]

NOTE

The Trigger is present, even if the pin is not available.

Table 4-7. MIBADC2 Event Trigger Sources

Event #	SOURCE SELECT BITS for G1, G2 or EVENT (G1SRC[2:0], G2SRC[2:0] or EVSRC[2:0])	Hookup
1	0	AD2EVT
2	1	NHET[8]
3	10	NHET[10]
4	11	RTI compare 0
5	100	NHET[17]
6	101	NHET[19]
7	110	GIOB[0]
8	111	GIOB[1]

NOTE

The Trigger is present, even if the pin is not available.

The application can generate the trigger condition using these signals by configuring the corresponding device pins as input pins and driving them from an external source, or by configuring them as output pins and driving them by software. The pin doesn't have to be present on the package to be able to be used as a trigger.

The interrupt request signals (RTI compare 0) are driven HIGH when the interrupt condition occurs. So if the ADC is required to be triggered on the interrupt being asserted, select the rising edge for this trigger source. The ADC can be still triggered using the falling edge on the interrupt line. In this case, the falling edge occurs when the interrupt line is deasserted.

4.6 MIBSPI

4.6.1 MIBSPI Event Trigger Sources

The Multi-buffered Serial Peripheral Interfaces (MIBSPIs) have a programmable buffer memory that enables data transmission to be completed without CPU intervention. The buffers are combined in different Transfer Groups (TGs) that can be triggered by external events such as I/O activity, timers or by the internal tick counter. The internal tick counter supports the periodic trigger of events. Each buffer of the MibSPI can be associated with different DMA channels in different TGs, allowing the user to move data between internal memory and an external slave with minimal CPU interaction.

Table 4-8. MIBSPI1 Event Trigger Sources

Event	TGxCTRL TRIGSRC[3:0]	Hookup
Disabled	0	No trigger source
EVENT0	1	GIOA[0]
EVENT1	10	GIOA[1]
EVENT2	11	GIOA[2]
EVENT3	100	GIOA[3]
EVENT4	101	GIOA[4]
EVENT5	110	GIOA[5]
EVENT6	111	GIOA[6]
EVENT7	1000	GIOA[7]
EVENT8	1001	NHET[8]
EVENT9	1010	NHET[10]
EVENT10	1011	NHET[12]
EVENT11	1100	NHET[14]
EVENT12	1101	NHET[16]
EVENT13	1110	NHET[18]
EVENT14	1111	Internal Tick counter

Table 4-9. MIBSPI3 Event Trigger Sources

Event	TGxCTRL TRIGSRC[3:0]	Hookup
Disabled	0	No trigger source
EVENT0	1	GIOA[0]
EVENT1	10	GIOA[1]
EVENT2	11	GIOA[2]
EVENT3	100	GIOA[3]
EVENT4	101	GIOA[4]
EVENT5	110	GIOA[5]
EVENT6	111	GIOA[6]
EVENT7	1000	GIOA[7]
EVENT8	1001	NHET[8]
EVENT9	1010	NHET[10]
EVENT10	1011	NHET[12]
EVENT11	1100	NHET[14]
EVENT12	1101	NHET[16]
EVENT13	1110	NHET[18]
EVENT14	1111	Internal Tick counter

Table 4-10. MIBSPI5 Event Trigger Sources

Event	TGxCTRL TRIGSRC[3:0]	Hookup
Disabled	0	No trigger source
EVENT0	1	GIOA[0]
EVENT1	10	GIOA[1]
EVENT2	11	GIOA[2]
EVENT3	100	GIOA[3]
EVENT4	101	GIOA[4]
EVENT5	110	GIOA[5]
EVENT6	111	GIOA[6]
EVENT7	1000	GIOA[7]
EVENT8	1001	NHET[8]
EVENT9	1010	NHET[10]
EVENT10	1011	NHET[12]
EVENT11	1100	NHET[14]
EVENT12	1101	NHET[16]
EVENT13	1110	NHET[18]
EVENT14	1111	Internal Tick counter

4.6.2 MIBSPI5/DMM Pin Multiplexing

The multiplexing of MIBSPI5 and DMM pins are controlled by the status of the MIBSPI5 module and the DMM module. The pins will have DMM functionality if the DMM module is enabled and the MIBSPI5 module is disabled; if the MIBSPI5 is enabled the pins will have MIBSPI functionality, regardless of the DMM module status. DMMCLK, DMMSYNC, DMMENA and DMMDATA[1:0] are always functional independent of the MIBSPI5 configuration because they are not multiplexed. The related pin numbers can be found in the MIBSPI5 and the DMM section of the Terminal Functions chapter. The following table shows the MIBSPI5 and DMM Data pin multiplexing.

Table 4-11. MIBSPI5 Pin Multiplexing

MIBSPI5 enabled	DMM enabled & MIBSPI5 disabled
MIBSPI5CLK	DMMDATA[4]
$\overline{\text{MIBSPI5CS}}[0]$	DMMDATA[5]
$\overline{\text{MIBSPI5CS}}[1]$	DMMDATA[6]
$\overline{\text{MIBSPI5CS}}[2]$	DMMDATA[2]
$\overline{\text{MIBSPI5CS}}[3]$	DMMDATA[3]
MIBSPI5ENA	DMMDATA[7]
MIBSPI5SIMO[0]	DMMDATA[8]
MIBSPI5SIMO[1]	DMMDATA[9]
MIBSPI5SIMO[2]	DMMDATA[10]
MIBSPI5SIMO[3]	DMMDATA[11]
MIBSPI5SOMI[0]	DMMDATA[12]
MIBSPI5SOMI[1]	DMMDATA[13]
MIBSPI5SOMI[2]	DMMDATA[14]
MIBSPI5SOMI[3]	DMMDATA[15]

4.7 ETM

The device contains an ARM Cortex™-R4F External Trace Macrocell (ETM-R4) with a 32bit data port. The ETM-R4 module is connected to a Test Port Interface Unit (TPIU) with a 32bit data bus. The ETM-R4 is CoreSight compliant and follows the ARM ETM v3 specification; for more details see ARM CoreSight™ ETM-R4 TRM specification Revr0p0. The ETM-R4 supports "half rate clocking" only.

The ETM clock source can be selected as either VCLK or the external ETMTRACECLKIN pin. The selection is done by the EXTCTRL0UT[1:0] control bits of the TPIU; the default is '00'.

Table 4-12. ETMTRACECLKIN Selection

EXTCTRL0UT[1:0]	TPIU/TRACECLKIN
0	tied-low
1	VCLK
10	ETMTRACECLKIN
11	tied-zero

4.8 Debug Scan Chains

The device contains an ICEPICK module to access the debug scan chains. Debug scan chain #0 handles the access to the CPU, to the ETM-R4 (External Trace Macrocell), to the POM (Parameter Overlay Module) and to the TPIU (Test Port Interface Unit). Debug scan chain #1 handles the access to the Ram Trace Port (RTP) and the Data Modification Module (DMM) which each incorporate a dedicated TAP (Test Access Port) controller. Each module is selected via its scan chain number. The IcePick scan ID is 0x80206D05, which is the same number as the device ID.

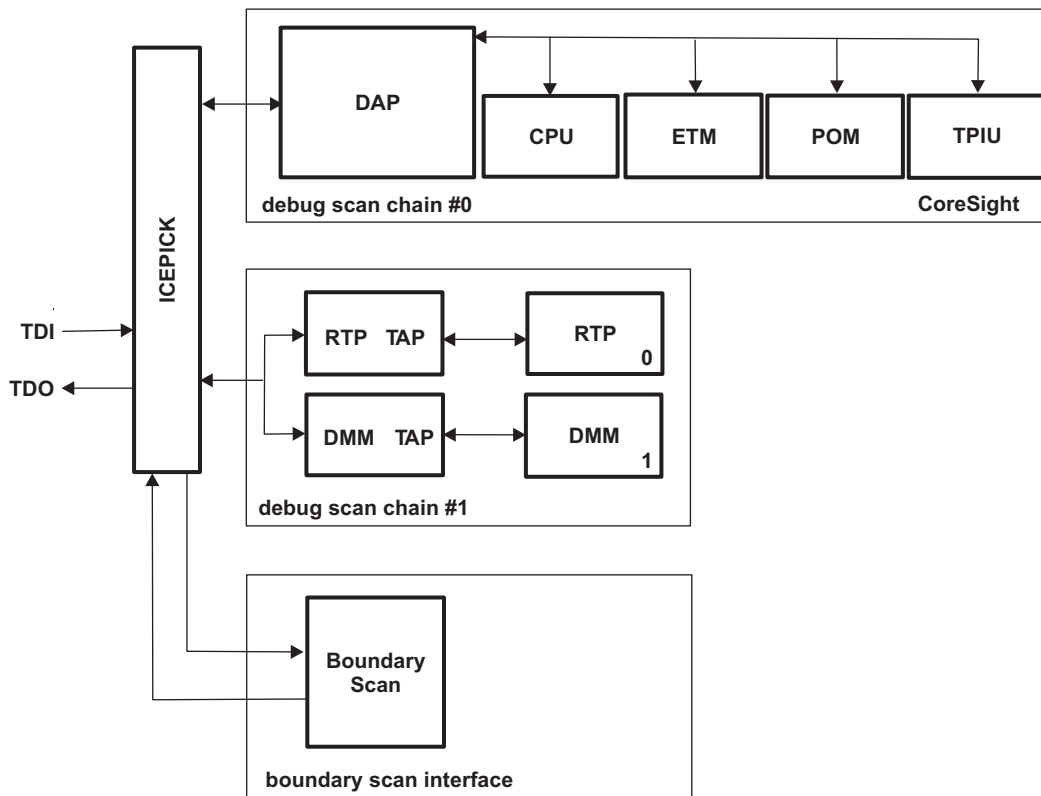

Figure 4-1. Debug Scan Chains

PRODUCT PREVIEW

4.8.1 JTAG

The 32bit JTAG ID code for this device is 0x0B7B302F.

PRODUCT PREVIEW

4.9 CCM

4.9.1 Dual Core Implementation

The microcontroller has two Cortex-R4 cores, where the output signals of both CPUs are compared in the CCM-R4 (Core Compare Module). To avoid common mode impacts the signals of the CPUs to be compared are delayed in a different way as shown in the following figure..

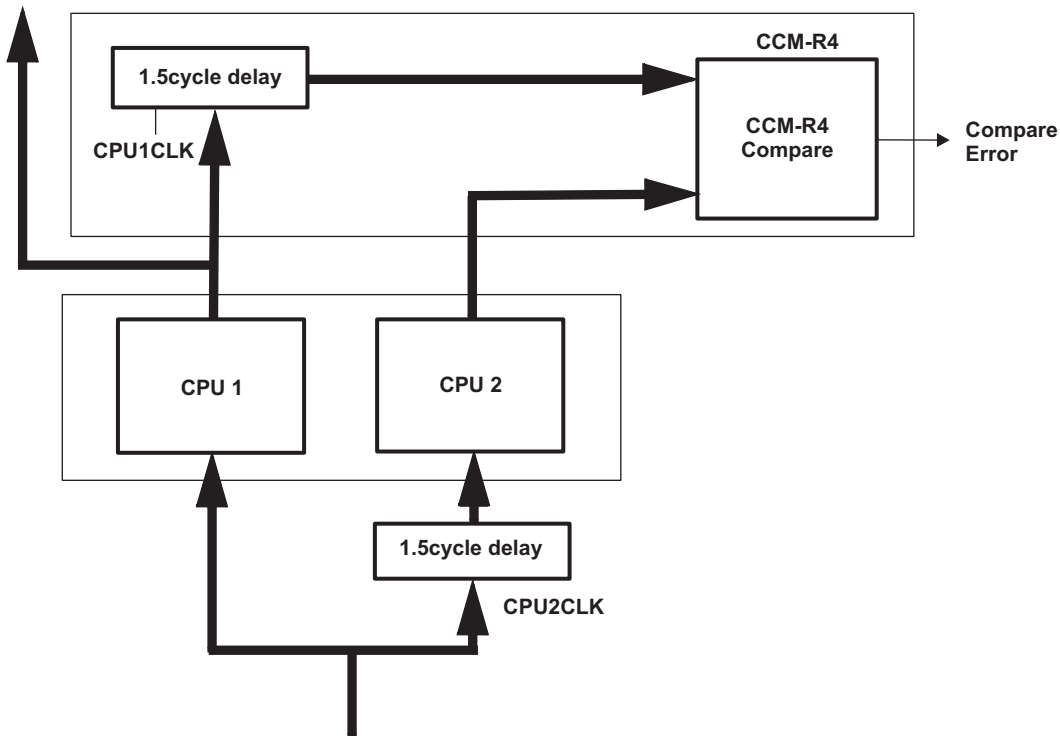

Figure 4-2. Dual Core Implementation

4.9.2 CCM-R4

To avoid an erroneous CCM-R4 compare error, the application software must ensure that the CPU registers of both CPUs are initialized with the same values before the 1st function call or other operation that pushes the CPU registers onto the stack. All CCM-R4 error forcing test modes are limited to 100MHz HCLK speed.

4.10 LPM

TMS570 Platform devices support multiple low power modes. These different modes allow the user to trade-off the amount of current consumption during low power mode versus functionality and wake-up time.

Supported Low Power modes on this devices are Doze, Snooze and Sleep; for detailed description please refer to the Architecture section of the Technical Reference Manual.

4.11 Voltage Monitor

A voltage monitor has been implemented on this device. The purpose of this voltage monitor is to eliminate the requirement for a specific sequence when powering up the core and I/O voltage supplies. It also reduces the risk of corrupting memory or glitches on I/O pins during power-up, power-down or brown outs. The voltage monitor does not eliminate the need of a voltage supervisor circuit to guarantee that the device is held in reset when the voltage supplies are out of range. The voltage monitor thresholds can be found in the Vmon section of the device electrical specifications.

When the voltage monitor detects a low voltage on the I/O supply, it will assert a reset. When the voltage monitor detects a low voltage on the core supply, it asynchronously makes all output pins high impedance, and asserts a reset. The voltage monitor is disabled when the device is in halt mode.

The voltage monitor has three filter functions:

- It rejects short low-going glitches on the $\overline{\text{PORRST}}$ pin
- It rejects noise on the VCCIO supply
- It rejects noise on the VCC supply

Please note that such glitches on VCC and VCCIO could still corrupt the system depending on many factors. The width of noise that can be filtered by the voltage monitor on the VCC and VCCIO supplies is shown in the table below. The duration of glitches that will be filtered on the $\overline{\text{PORRST}}$ pin can be found in [Table 7-5, Timing Requirements for \$\overline{\text{PORRST}}\$](#) .

Table 4-13. VMON Supply Glitch Filter Capability

Parameter	Min	Max
Width of glitch on VCC that can be filtered out	250ns	1us
Width of glitch on VCCIO that can be filtered out	300ns	1us

4.12 CRC

MCRC Controller is a module which is used to perform CRC (Cyclic Redundancy Check) to verify the integrity of memory system. A signature representing the contents of the memory is obtained when the contents of the memory are read into MCRC Controller. The responsibility of MCRC controller is to calculate the signature for a set of data and then compare the calculated signature value against a pre-determined good signature value. MCRC controller provides up to four channels to perform CRC calculation on multiple memories in parallel and can be used on any memory system. Channel 1 can also be put into data trace mode. In data trace mode, MCRC controller compresses each data being read through the CPU read data bus.

When using the MCRC module in PSA mode while ECC is enabled, bus masters (e.g. FTU, HTU, DMA or CPU) should not write to the data RAM (TCRAM) to avoid corrupting the PSA value.

4.13 System Module

The system module access modes and access rights are shown in the following table.

Table 4-14. System Module Access

Domain	Module	Access Mode Used by Module	Access Rights Required to Access the Module RAMS
System	VIM	n/a	privilege mode (RWP)
System	RTP	n/a	privilege mode (RWP)
System	DMA	user mode	privilege mode (RWP)
Peripheral	HTU	privilege mode	privilege mode (RWP)
Peripheral	FTU	user & privilege mode	user & privilege mode (RW)

4.14 Debug ROM

The Debug ROM stores the location of the components on the Debug APB bus.

Table 4-15. Debug ROM Table

Address	Description	Value
Components Table		
0x000	pointer to Cortex-R4	0x00001003
0x000	ETM	0x00002003
0x000	TPIU	0x00003003
0x000	POM	0x00004003
0x001	end of table	0x00000000

4.15 CPU Self Test Controller: STC / LBIST

The CPU Self Test Controller (STC) is used to test the ARM CPU core using a Deterministic Logic BIST (LBIST) Controller as the test engine. The STC has the capability of dividing the complete test run into smaller independent test sets (intervals). The test coverage and number of test execution cycles for each test interval is shown in the table below.

The maximum clock rate for the STC / LBIST is:

- 53.333MHz when HCLK = 160MHz / VCLK = 80MHz on BGA package
- 50MHz when HCLK = 100MHz / VCLK = 100MHz on QFP and BGA packages
- 46.666MHz when HCLK = 140MHz / VCLK = 70MHz on QFP and BGA packages

In order to achieve the proper clock rate during CPU self test a STC clock divider has been implemented. The clock divider is set by the CLKDIV bits in STCCLKDIV register in the secondary system module frame at location 0xFFFF E108. The default value of the CPU Self Test LBIST clock divider is set to divide-by-1'.

NOTE

The supply current while performing CPU self test is different than the device operating mode current. These values can be found in the I_{cc} section of the device electrical specifications.

Table 4-16. STC/LBIST Test Coverage and Duration

Intervals	Test Coverage	Test Cycles
0	0	0
1	57,14	1555
2	65,82	3108
3	70,56	4661
4	73,56	6214
5	76,06	7767
6	78,07	9320
7	79,62	10873
8	80,92	12426
9	82,1	13979
10	82,94	15532
11	83,76	17085
12	84,51	18638
13	85,12	20191
14	85,62	21744
15	86,19	23297
16	86,56	24850
17	86,97	26403
18	87,33	27956
19	87,67	29509
20	88,01	31062
21	88,31	32615
22	88,58	34168
23	88,87	35721
24	89,11	37274
25	89,34	38827
26	89,59	40380
27	89,82	41933

Table 4-16. STC/LBIST Test Coverage and Duration (continued)

Intervals	Test Coverage	Test Cycles
28	90,05	43486
29	90,26	45039
30	90,46	46592
31	90,64	48145
32	90,84	49698

5 Device Registers

5.1 Device Identification Code Register

The device identification code register identifies several aspects of the device including the silicon version. The details of the device identification code register are shown in Figure 11. The device identification code register value for this device is:

- Rev 0 = 0x80206D05
- Rev A = 0x80206D0D

Figure 5-1. Device ID Bit Allocation Register

31	30	29	28	27	26	25	24	23	22	21	20	19	18	17	16
CP-15	UNIQUE ID														16
R-1	R-00000 0000 10000														R-0
15	14	13	12	11	10	9	8	7	6	5	4	3	2	1	0
TECH		I/O VOLTAGE	PERIPHERAL PARITY	FLASH ECC		RAM ECC	VERSION					1	0	1	
R-0		R-0	R-1	R-10		R-1	R-1					R-1	R-0	R-1	

LEGEND: R/W = Read/Write; R = Read only; -n = value after reset; D= device dependent

Table 5-1. Device ID Bit Allocation Register Field Descriptions

Bit	Field	Value	Description
31	CP15	0 1	Indicates the presence of coprocessor 15 CP15 not present CP15 present
30-17	UNIQUE ID	1	Silicon version (revision) bits This bitfield holds a unique number for a dedicated device configuration (die).
16-13	TECH	0000 0001 0010 0011 Others	Process technology on which the device is manufactured. C05 F05 C035 F035 Reserved
12	I/O VOLTAGE	0 1	I/O voltage of the device. I/O are 3.3v I/O are 5v
11	PERIPHERAL PARITY	0 1	Peripheral Parity No parity on peripherals Parity on peripherals
10-9	FLASH ECC	00 01 10 11	Flash ECC No error detection/correction Program memory with parity Program memory with ECC Reserved
8	RAM ECC	0 1	Indicates if RAM memory ECC is present. No ECC implemented ECC implemented

PRODUCT PREVIEW

Table 5-1. Device ID Bit Allocation Register Field Descriptions (continued)

Bit	Field	Value	Description
7-3	REVISION		Revision of the Device.
2-0	101		The platform family ID is always 0b101

5.2 Die-ID Registers

The two registers (DIEIDL and DIEIDH) form a 64-bit number that contains information about the device's die lot number, wafer number and X, Y wafer coordinates. The die identification information will vary from unit to unit. This information is programmed by TI as part of the initial device test procedure. The data format of the Die-ID registers is shown here.

Figure 5-2. DIEIDL Register (Location: 0xFFFF FF7C)

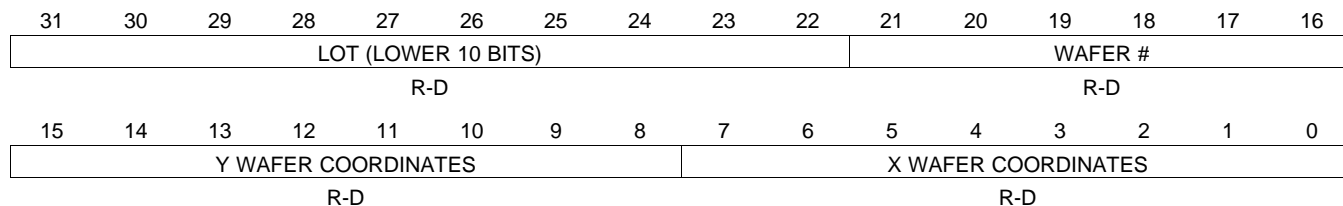

LEGEND: R/W = Read/Write; R = Read only; -n = value after reset; D= device dependent

Figure 5-3. DIEIDH Register (Location: 0xFFFF FF80)

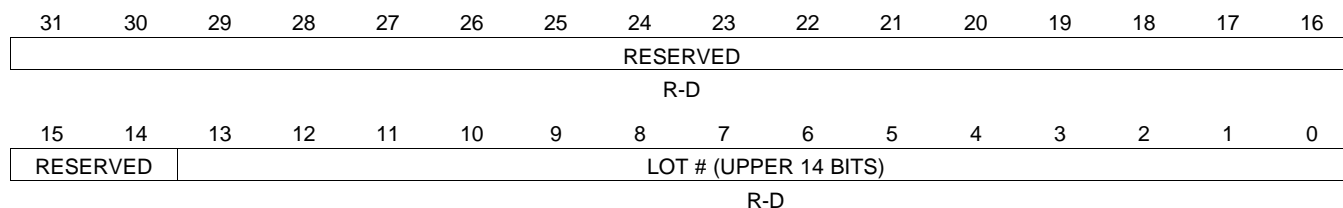

LEGEND: R/W = Read/Write; R = Read only; -n = value after reset; D= device dependent

PRODUCT PREVIEW

5.3 PLL Registers

The default values for the PLL (Phase Locked Loop) control registers are shown in this section. PLLCTL1 and PLLCTL2 are used to configure PLL1 (F035 FMzPLL) and PLLCTL3 is used to configure PLL2 (F035 FPLL).

Figure 5-4. PLLCTL1 Register (Location: 0xFFFF FF70)

31	30	29	28	27	26	25	23	223	21	20	19	18	17	16	
ROS	BPOS[1:0]		PLLDIV[4:0]				ROF	RESERVED			REFCLKDIV[5:0]				
R/WP-0	R/WP-01		R/WP-111				R/WP-0	R-0			R/WP-000010				
15	14	13	12	11	10	9	8	7	6	5	4	3	2	1	0
PLLMUL[15:0]															
R/WP-0101111100000000101															

LEGEND: R/W = Read/Write; R = Read only; -n = value after reset; D= device specific

Figure 5-5. PLLCTL2 Register (Location: 0xFFFF FF74)

31	30	29	28	27	26	25	24	23	22	21	20	19	18	17	16
FMEN A			SPREADINGRATE[8:0]							RESV		EWADJ[8:4]			
R/WP-0			R/WP-111111111							R-0		R/WP-00000			
15	14	13	12	11	10	9	8	7	6	5	4	3	2	1	0
	BWADJ[3:0]		ODPLL							SPR_AMOUNT[8:0]					
	R/WP-0111		R/WP-001							R/WP-000000000					

LEGEND: R/W = Read/Write; R = Read only; -n = value after reset; D = device specific

NOTE

There are several combinations of the modulation depth and modulation frequency that are not allowed. Valid settings for this device include the following: TBD

Figure 5-6. PLLCTL3 Register (Location: 0xFFFF E100)

31	30	29	28	27	26	25	24	23	22	21	20	19	18	17	16
			RESERVED						OSC DIV			RESERVED			
			R/W-000000000						R/WP-0			R/W-000000			
15	14	13	12	11	10	9	8	7	6	5	4	3	2	1	0
	RESERVED		PLL_MUL[3:0]						RESERVED			PLL_DIV [2:0]			
	R/W-000000		R/WP-011						R/W-00000			R/WP 111			

LEGEND: R/W = Read/Write; R = Read only; -n = value after reset; D= device specific

6 Device Electrical Specifications

6.1 Operating Conditions

6.2 Absolute Maximum Ratings Over Operating Free-Air Temperature Range (unless otherwise noted)⁽¹⁾

Supply voltage ranges	$V_{CC}^{(2)}$	- 0.3 V to 2.1V
	V_{CCIO} , V_{CCAD} , V_{CCP} (Flash pump) (see Note 1)	- 0.3 V to 4.1V
Input voltage range	All input pins	- 0.3 V to 4.1 V
Input clamp current	$I_{IK}(V_I < 0 \text{ or } V_I > V_{CCIO})$	± 20 mA
	All pins except AD1IN[7:0], AD2IN[7:0], ADSIN[15:8]	
	$I_{IK}(V_I < 0 \text{ or } V_I > V_{CCAD})$	
	AD1IN[7:0], AD2IN[7:0], ADSIN[15:8]	± 10 mA
	total	± 40 mA
Operating free-air temperature ranges, T_A	A version	- 40°C to 85°C
	T version	- 40°C to 105°C
	Q version	- 40°C to 125°C
Operating junction temperature range, T_J		-40°C to 150°C
Storage temperature range, T_{stg}		- 65°C to 150°C

- (1) Stresses beyond those listed under “absolute maximum ratings” may cause permanent damage to the device. These are stress ratings only, and functional operation of the device at these or any other conditions beyond those indicated under “recommended operating conditions” is not implied. Exposure to absolute-maximum-rated conditions for extended periods may affect device reliability
- (2) All voltage values are with respect to their associated grounds.

6.3 Device Recommended Operating Conditions⁽¹⁾

		MIN	NOM	MAX	Unit
V_{CC}	Digital logic supply voltage (Core)	1.35	1.5	1.65	V
V_{CCIO}	Digital logic supply voltage (I/O)	3	3.3	3.6	V
V_{CCAD}	MibADC supply voltage	3	3.3	3.6	V
V_{CCP}	Flash pump supply voltage	3	3.3	3.6	V
V_{SS}	Digital logic supply ground		0		V
V_{SSAD}	MibADC supply ground	-0.1		0.1	V
T_A	Operating free-air temperature	A version		85	°C
		T version	-40	105	°C
		Q version	-40	125	°C
T_J	Operating junction temperature	-40		150	°C

- (1) All voltages are with respect to V_{SS} except V_{CCAD} is with respect to V_{SSAD} .

6.4 Electrical Characteristics Over Operating Free-Air Temperature Range⁽¹⁾

Parameter			Test Conditions	MIN	TYP	MAX	Unit
V _{hys}	Input hysteresis			0.15			V
V _{IL}	Low-level input voltage	All inputs ⁽²⁾		-0.3		0.8	V
V _{IH}	High-level input voltage	All inputs		2		V _{CCIO} + 0.3	V
V _{OL}	Low-level output voltage		I _{OL} = I _{OL} MAX			0.2 V _{CCIO}	V
			I _{OL} = 50 μA			0.2	
V _{OH}	High-level output voltage		I _{OH} = I _{OH} MAX	0.8 V _{CCIO}			V
			I _{OH} = 50 μA	V _{CCIO} - 0.2			
V _{ILoscin}	Low-level input voltage	OSCIN		-0.3		0.2 V _{CC}	V
V _{IHoscin}	High-level input voltage	OSCIN		0.8 V _{CC}		V _{CC} + 0.3	V
V _{MON}	Voltage monitoring threshold	VCC low		1.1	1.2	1.35	V
		VCC high		1.7	2	2.38	
		VCCIO low		2.0	2.4	3.0	
I _{IC}	Input clamp current		V _I < V _{SSIO} - 0.3 or V _I > V _{CCIO} + 0.3	-2		2	mA
I _I	Input current (I/O pins)	I _{IL} Pulldown	V _I = V _{SS}	-1		1	μA
		I _{IH} Pulldown 20 mA	V _I = V _{CCIO}	5		40	
		I _{IH} Pulldown 100 mA	V _I = V _{CCIO}	40		195	
		I _{IL} Pullup 20 mA	V _I = V _{SS}	-40		-5	
		I _{IL} Pullup 100 mA	V _I = V _{SS}	-195		-40	
		I _{IH} Pullup	V _I = V _{CCIO}	-1		1	
		All other pins	No pullup or pulldown	-1		1	

(1) Source currents (out of the device) are negative while sink currents (into the device) are positive.

(2) This does not apply to PORRST pin.

Electrical Characteristics Over Operating Free-Air Temperature Range ⁽¹⁾ (continued)

Parameter		Test Conditions	MIN	TYP	MAX	Unit
I _{OL}	Low-level output current	TDO TDI TMS RTCK ECLK FRAYRX1 FRAYTX1 FRAYTXEN1 FRAYRX2 FRAYTX2 FRAYTXEN2 DMMENA ETMTRACECTL ETMTRACECLKO UT ETMDATA[31:0] RTPSYNC RTPCLK RTPDATA[15:0] DMMENA EMIFWE EMIFOE EMIFCS[3:0] EMIFDATA[15:0] EMIFADD[21:0] EMIFBADD[1:0] EMIFDQM[1:0] ERROR	V _{OL} = V _{OL} MAX		8	mA
		RST MIBSPI1CLK MIBSPI1SIMO MIBSPI1SOMI MIBSPI3CLK MIBSPI3SIMO MIBSPI3SOMI MIBSPI5CLK MIBSPI5SIMO[3:0] MIBSPI5SOMI[3:0] DMMDATA[15:8] DMMDATA[4] All other output pins	V _{OL} = V _{OL} MAX		4	2

PRODUCT PREVIEW

Electrical Characteristics Over Operating Free-Air Temperature Range ⁽¹⁾ (continued)

Parameter		Test Conditions	MIN	TYP	MAX	Unit
I_{OH}	High-level output current	TDO TDI TMS RTCK ECLK FRAYRX1 FRAYTX1 FRAYTXEN1 FRAYRX2 FRAYTX2 FRAYTXEN2 DMMENA ETMTRACECTL ETMTRACECLKO UT ETMDATA[31:0] RTPSYNC RTPCLK RTPDATA[15:0] \overline{DMMENA} \overline{EMIFWE} \overline{EMIFOE} $\overline{EMIFCS[3:0]}$ EMIFDATA[15:0] EMIFADD[21:0] EMIFBADD[1:0] EMIFDQM[1:0] ERROR	$V_{OH} = V_{OH\ MIN}$		-8	mA
		\overline{RST} MIBSPI1CLK MIBSPI1SIMO MIBSPI1SOMI MIBSPI3CLK MIBSPI3SIMO MIBSPI3SOMI MIBSPI5CLK MIBSPI5SIMO[3:0] MIBSPI5SOMI[3:0] DMMDATA[15:8] DMMDATA[4] All other output pins				
					-2	

PRODUCT PREVIEW

Electrical Characteristics Over Operating Free-Air Temperature Range ⁽¹⁾ (continued)

Parameter		Test Conditions	MIN	TYP	MAX	Unit
I _{CC} ⁽³⁾	V _{CC} Digital supply current (Operating mode)	All packages	HCLK = 100MHz, VCLK = 100MHz		350	mA
			HCLK = 140MHz, VCLK = 70MHz		390	mA
		BGA packages	HCLK = 160MHz, VCLK = 80MHz		430	mA
	V _{CC} Digital supply current (CPU selftest mode: LBIST)	All packages	LBIST (STC) CLK = 46.666MHz		450	mA
			LBIST (STC) CLK = 50.0MHz		500	mA
		BGA packages	LBIST (STC) CLK = 53.333MHz		550	mA
	V _{CC} Digital supply current (Mem selftest mode: PBIST)	All packages	HCLK=80MHz, VCLK=40MHz		320	mA
			HCLK=100MHz, VCLK=100MHz		400	mA
	V _{CC} Digital supply current (doze mode)		OSCIN = 6 MHz, V _{CC} = 1.65 V ⁽⁴⁾		35	mA
	V _{CC} Digital supply current (snooze mode)		All frequencies, V _{CC} = 1.65 V ⁽⁴⁾		30	mA
V _{CC} Digital supply current (sleep mode)		All frequencies, V _{CC} = 1.65 V ⁽⁴⁾		10	mA	
I _{CCIO}	V _{CCIO} Digital supply current (operating mode)		No DC load, V _{CCIO} = 3.6 V ⁽⁵⁾		15	mA
	V _{CCIO} Digital supply current (doze mode)		No DC load, V _{CCIO} = 3.6 V ⁽⁵⁾		100	mA
	V _{CCIO} Digital supply current (snooze mode)		No DC load, V _{CCIO} = 3.6 V ⁽⁵⁾		100	mA
	V _{CCIO} Digital supply current (sleep mode)		No DC load, V _{CCIO} = 3.6 V ⁽⁵⁾		100	mA
I _{CCAD}	V _{CCAD} supply current (operating mode)		All frequencies, V _{CCAD} = 3.6 V		30	mA
	V _{CCAD} supply current (doze mode)		All frequencies, V _{CCAD} = 3.6 V ⁽⁶⁾		10	mA
	V _{CCAD} supply current (snooze mode)		All frequencies, V _{CCAD} = 3.6 V ⁽⁶⁾		10	mA
	V _{CCAD} supply current (sleep mode)		All frequencies, V _{CCAD} = 3.6 V ⁽⁶⁾		10	mA
I _{CCP}	V _{CCP} pump supply current		V _{CCP} = 3.6 V read operation		25	mA
			V _{CCP} = 3.6 V program ⁽⁷⁾		90	mA
			V _{CCP} = 3.6 V erase		90	mA
			V _{CCP} = 3.6 V doze mode ⁽⁶⁾		5	mA
			V _{CCP} = 3.6 V snooze mode ⁽⁶⁾		5	mA
			V _{CCP} = 3.6 V sleep mode ⁽⁶⁾		5	mA
C _I	Input capacitance ⁽⁸⁾			2	pF	

(3) Typical values are at V_{cc}=1.5V and maximum values are at V_{cc}=1.65V
 (4) For Flash banks/pumps in sleep mode.
 (5) I/O pins configured as inputs or outputs with no load. All pulldown inputs ≤ 0.2 V. All pullup inputs ≥ V_{CCIO} - 0.2 V.
 (6) For Flash banks/pumps in sleep mode.
 (7) This assumes reading from one bank while programming the same bank.
 (8) The maximum input capacitance C_I of the Flexray RX pin(s) is 10pF.

Electrical Characteristics Over Operating Free-Air Temperature Range ⁽¹⁾ (continued)

Parameter		Test Conditions	MIN	TYP	MAX	Unit
C _O	Output capacitance			3		pF

PRODUCT PREVIEW

7 Peripheral and Electrical Specifications

7.1 Clocks

7.1.1 PLL And Clock Specifications

Table 7-1. Timing Requirements For PLL Circuits Enabled Or Disabled

		MIN	MAX	Unit
$f_{i(OSC)}$	Input clock frequency	5	20	MHz
$t_{c(OSC)}$	Cycle time, OSCIN	50		ns
$t_w(OSCIL)$	Pulse duration, OSCIN low	15		ns
$t_w(OSCIH)$	Pulse duration, OSCIN high	15		ns
$f_{i(OSCRST)}$	OSC FAIL frequency - upper level	20	50	MHz
$f_{i(OSCRST)}$	OSC FAIL frequency - lower level	1.5	5	MHz

7.1.2 External Reference Resonator/Crystal Oscillator Clock Option

The oscillator is enabled by connecting the appropriate fundamental 5–20 MHz resonator/crystal and load capacitors across the external OSCIN and OSCOUT pins as shown in section (a) of the figure below. The oscillator is a single stage inverter held in bias by an integrated bias resistor. This resistor is disabled during leakage test measurement and HALT mode.

NOTE

TI strongly encourages each customer to submit samples of the device to the resonator/crystal vendors for validation. The vendors are equipped to determine what load capacitors will best tune their resonator/crystal to the microcontroller device for optimum start-up and operation over temperature/voltage extremes.

An external oscillator source can be used by connecting a 1.5V clock signal to the OSCIN pin and leaving the OSCOUT pin unconnected (open) as shown in section (b) of the figure below.

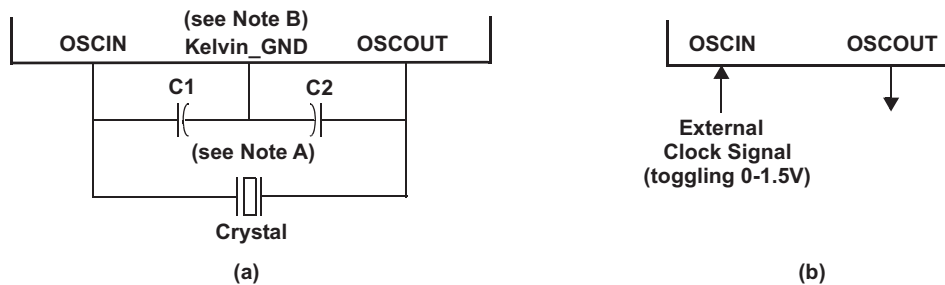

Figure 7-1. Recommended Crystal/Clock Connection

NOTE

In figure (a), The values of C1 and C2 should be provided by the resonator/crystal vendor.

In figure (b), Kelvin_GND should not be connected to any other GND.

7.1.3 LPO And Clock Detection

The LPOCLKDET module consists of a clock monitor (CLKDET) and 2 low power oscillators (LPO) - a low frequency (LF) and a high frequency (HF) oscillator. The CLKDET is a supervisor circuit for an externally supplied clock signal. In case the externally supplied clock frequency falls out of a frequency window, the clock detector flags this condition and switches to the HF LPO clock (limp mode). The OSCFAIL flag and clock switch-over remain, regardless of the behavior of the oscillator clock signal. The only way OSCFAIL can be cleared (and re-enable OSCIN as the clock source) is a power-on-reset.

Table 7-2. LPO And Clock Detection

Parameter		MIN	Type	MAX	Unit
Invalid frequency	lower threshold	1.5		5	MHz
	upper threshold	20		50	MHz
Limp mode frequency (HFosc)		TBD	10	TBD	MHz
HFosc frequency		TBD	10	TBD	MHz
LFosc frequency		TBD	80	TBD	kHz

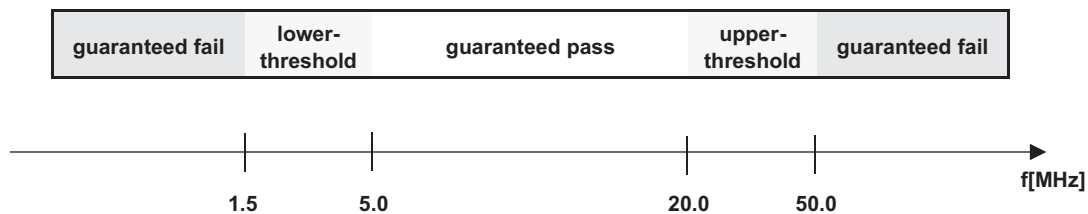

Figure 7-2. LPO And Clock Detection

7.1.4 Switching Characteristics Over Recommended Operating Conditions For Clocks

Table 7-3. Switching Characteristics Over Recommended Operating Conditions For Clocks

Parameter		Test Conditions	MIN	MAX	Unit
f _(HCLK)	HCLK - System clock frequency (BGA packages)	Pipeline mode enabled		160	MHz
		Pipeline mode disabled		36	MHz
f _(HCLK)	HCLK - System clock frequency (144pin QFP package)	Pipeline mode enabled		140	MHz
		Pipeline mode disabled		36	MHz
f _(GCLK)	GCLK - CPU clock frequency (ratio GCLK : HCLK = 1:1)			f _(HCLK)	MHz
f _(RTICK)	RTICK - clock frequency			f _(VCLK)	MHz
f _(VCLK)	VCLK - Primary peripheral clock frequency			100	MHz
f _(VCLK2)	VCLK2 - Secondary peripheral clock frequency			f _(VCLK)	MHz
f _(AVCLK1)	AVCLK1 - Primary asynchronous peripheral clock frequency			f _(VCLK)	MHz
f _(AVCLK2)	AVCLK2 - Secondary asynchronous peripheral clock frequency			f _(VCLK)	MHz
f _(ECLK) ⁽¹⁾	ECLK - External clock output frequency for ECP Module			80	MHz
f _(PROG/ERASE)	System clock frequency - Flash programming/erase			f _(HCLK)	MHz

(1) (ECLK) = f(VCLK) / N, where N = {1 to 65536}. N is the ECP prescale value defined by the ECPCNTL[15:0] register bits in the System module. Pipeline mode enabled or disabled is determined by the FRDCNTL[2:0].

7.1.4.1 Timing - Wait States

RAM

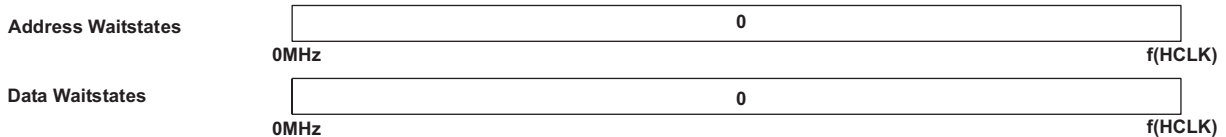

Flash



Figure 7-3. Wait States

NOTE

If FMzPLL frequency modulation is enabled, special care must be taken to ensure that the maximum system clock frequency f(HCLK) and peripheral clock frequency f(VCLK) are not exceeded. The speed of the device clocks may need to be derated to accommodate the modulation depth when FMzPLL frequency modulation is enabled.

PRODUCT PREVIEW

7.2 ECLK Specification

7.2.1 Switching Characteristics Over Recommended Operating Conditions For External Clocks

Table 7-4. Switching Characteristics Over Recommended Operating Conditions For External Clocks⁽¹⁾⁽²⁾

NO.	Parameter		Test Conditions	MIN	MAX	Unit
3	$t_{w(EOL)}$	Pulse duration, ECLK low	under all prescale factor combinations (X and N)	$0.5t_c(ECLK) - t_f$		ns
4	$t_{w(EOH)}$	Pulse duration, ECLK high	under all prescale factor combinations (X and N)	$0.5t_c(ECLK) - t_r$		ns

- (1) X = {1,2,3,4,5,6,7,8,9,10,11,12,13,14,15,16}. X is the VBUS interface clock divider ratio determined by the CLKCNTL.[19:16] bits in the SYS module.
 (2) N = {1 to 65536}. N is the ECP prescale value defined by the ECPCNTL.[15:0] register bits in the System module.

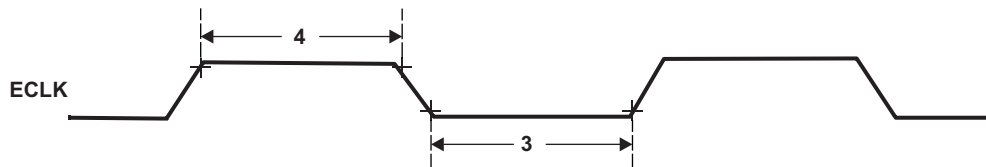

Figure 7-4. ECLK Timing Diagram

7.3 RST And PORRST Timings

7.3.1 Timing Requirements For $\overline{\text{PORRST}}$

Table 7-5. Timing Requirements For $\overline{\text{PORRST}}$

NO.			MIN	MAX	Unit
	V_{CCPORL}	V_{CC} low supply level when $\overline{\text{PORRST}}$ must be active during power up		0.5	V
	V_{CCPORH}	V_{CC} high supply level when $\overline{\text{PORRST}}$ must remain active during power up and become active during power down	1.35		V
	V_{CCIOPORL}	$V_{\text{CCIO}} / V_{\text{CCP}}$ low supply level when $\overline{\text{PORRST}}$ must be active during power up		1.1	V
	V_{CCIOPORH}	$V_{\text{CCIO}} / V_{\text{CCP}}$ high supply level when $\overline{\text{PORRST}}$ must remain active during power up and become active during power down	3		V
	$V_{\text{IL}}(\overline{\text{PORRST}})$	Low-level input voltage of $\overline{\text{PORRST}}$ $V_{\text{CCIO}} > 2.5\text{V}$		$0.2 V_{\text{CCIO}}$	V
		Low-level input voltage of $\overline{\text{PORRST}}$ $V_{\text{CCIO}} < 2.5\text{V}$		0.5	V
3	$t_{\text{su}}(\overline{\text{PORRST}})$	Setup time, $\overline{\text{PORRST}}$ active before V_{CCIO} and $V_{\text{CCP}} > V_{\text{CCIOPORL}}$ during power up	0		ms
6	$t_{\text{h}}(\overline{\text{PORRST}})$	Hold time, $\overline{\text{PORRST}}$ active after $V_{\text{CC}} > V_{\text{CCPORH}}$	1		ms
7	$t_{\text{su}}(\overline{\text{PORRST}})$	Setup time, $\overline{\text{PORRST}}$ active before $V_{\text{CC}} \leq V_{\text{CCPORH}}$ during power down	8		ms
8	$t_{\text{h}}(\overline{\text{PORRST}})$	Hold time, $\overline{\text{PORRST}}$ active after V_{CCIO} and $V_{\text{CCP}} > V_{\text{CCIOPORH}}$	1		ms
9	$t_{\text{h}}(\overline{\text{PORRST}})$	Hold time, $\overline{\text{PORRST}}$ active after $V_{\text{CC}} < V_{\text{CCPORL}}$	0		ms
	$t_{\text{f}}(\overline{\text{PORRST}})$	Filter time $\overline{\text{PORRST}}$, pulses less than MIN will be filtered out, pulses greater than MAX are guaranteed to generate a reset	30	150	ns
	$t_{\text{f}}(\text{RST})$	Filter time RST , pulses less than MIN will be filtered out, pulses greater than MAX are guaranteed to generate a reset	40	150	ns

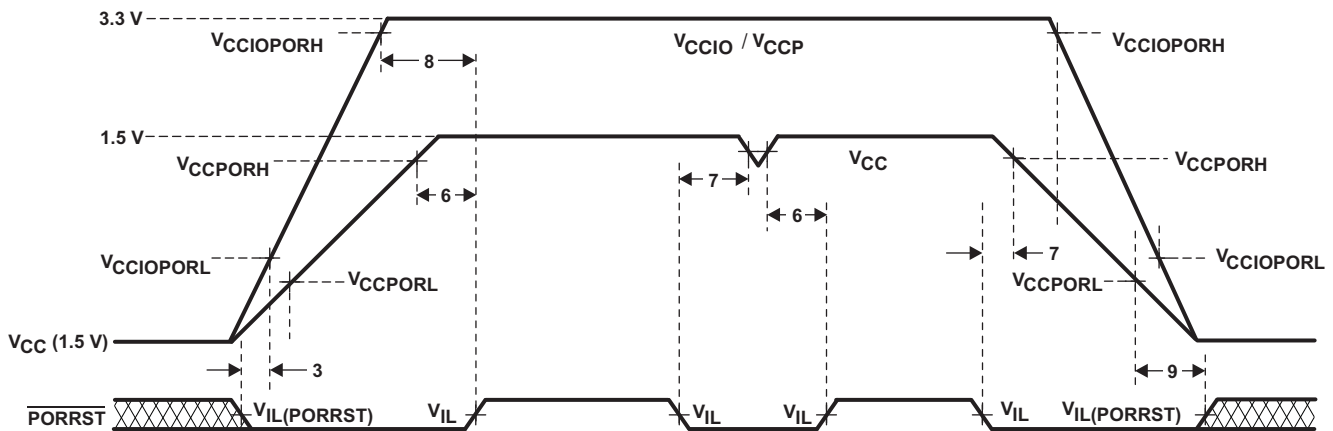

Figure 7-5. PORRST Timing Diagram

NOTE

There is no timing dependency between the ramp of the VCCIO and the VCC supply voltage; this is just an exemplary drawing. All requirements are to ensure $\overline{\text{PORRST}}$ is active when VCCIO or VCC is out of the normal operating range.

7.3.2 Switching Characteristics Over Recommended Operating Conditions For \overline{RST}

Table 7-6. Switching Characteristics Over Recommended Operating Conditions For \overline{RST} ⁽¹⁾

	Parameter	MIN	MAX	Unit
$t_{V(RST)}$	Valid time, \overline{RST} active after \overline{PORRST} inactive	1048 _{c(OSC)}		ns
	Valid time, \overline{RST} active (all others)	8 _{tC(VCLK)}		

(1) Specified values do NOT include rise/fall times. For rise and fall timings, see the switching characteristics for output timings versus load capacitance table.

7.4 DAP - JTAG Scan Interface Timing

7.4.1 JTAG clock specification 12-MHz and 50-pF load on TDO output

Table 7-7. JTAG Scan Interface Timing

NO.			MIN	MAX	Unit
	$f_{(TCK)}$	TCK frequency (at HCLKmax)		12	MHz
	$f_{(RTCK)}$	RTCK frequency (at TCKmax and HCLKmax)	10		MHz
1	$t_{d(TCK - RTCK)}$	Delay time, TCK to RTCK		20	ns
2	$t_{su(TDI/TMS - RTCKr)}$	Setup time, TDI, TMS before RTCK rise (RTCKr)	15		ns
3	$t_{h(RTCKr - TDI/TMS)}$	Hold time, TDI, TMS after RTCKr	0		ns
4	$t_{h(RTCKr - TDO)}$	Hold time, TDO after RTCKr	0		ns
5	$t_{d(RTCKf - TDO)}$	Delay time, TDO valid after RTCK fall (RTCKf)		10	ns

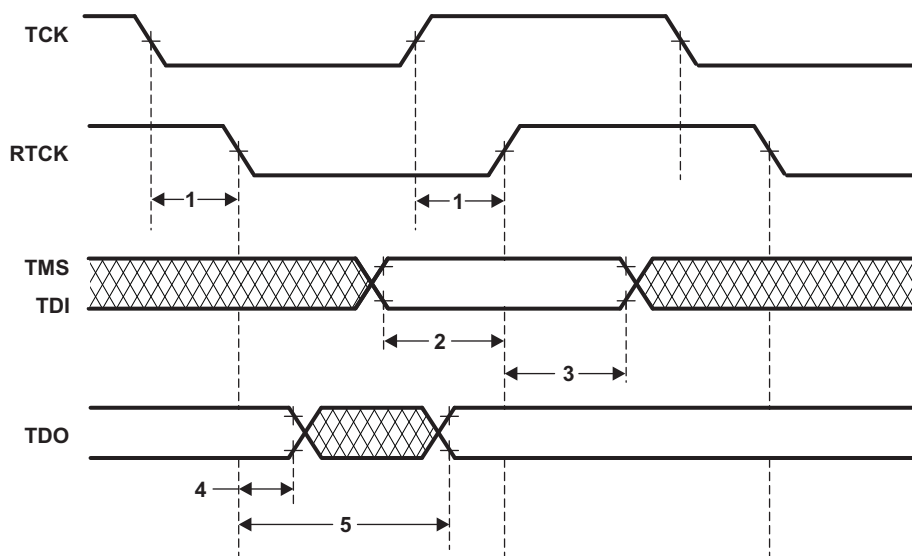

Figure 7-6. JTAG timing

7.5 Output Timings

7.5.1 Switching Characteristics For Output Timings Versus Load Capacitance (C_L)

Table 7-8. Switching Characteristics For Output Timings Versus Load Capacitance (C_L)

Parameter		MIN	MAX	Unit	
t _r	8mA pins	C _L = 15 pF		2.5	ns
		C _L = 50 pF		5	
		C _L = 100 pF		9	
		C _L = 150 pF		12	
t _f	8mA pins	C _L = 15 pF		2.5	ns
		C _L = 50 pF		5	
		C _L = 100 pF		9	
		C _L = 150 pF		12	
t _r	4mA pins	C _L = 15 pF		7	ns
		C _L = 50 pF		13	
		C _L = 100 pF		21	
		C _L = 150 pF		29	
t _f	4mA pins	C _L = 15 pF		7	ns
		C _L = 50 pF		13	
		C _L = 100 pF		21	
		C _L = 150 pF		29	
t _r	2mA-z pins	C _L = 15 pF		10	ns
		C _L = 50 pF		17	
		C _L = 100 pF		25	
		C _L = 150 pF		35	
t _f	2mA-z pins	C _L = 15 pF		10	ns
		C _L = 50 pF		17	
		C _L = 100 pF		25	
		C _L = 150 pF		35	

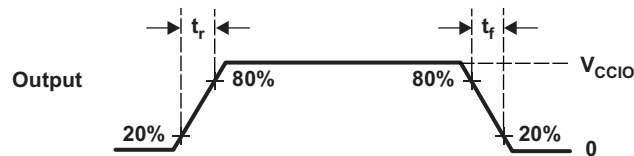

Figure 7-7. CMOS-Level Outputs

7.6 Input Timings

7.6.1 Timing Requirements For Input Timings⁽¹⁾

Table 7-9. Timing Requirements For Input Timings

		MIN	MAX	Unit
t_{pw}	Input minimum pulse width	$t_{c(VCLK)} + 10^{(1)}$		ns

- (1) $t_{c(VCLK)}$ = peripheral VBUS clock cycle time = $1 / f_{(VCLK)}$
 (1) The timing shown above is only valid for pin used in GPIO mode

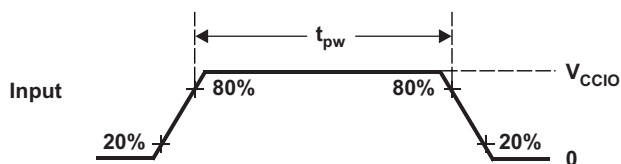

Figure 7-8. CMOS-Level Inputs

7.7 Flash Timings

Table 7-10. Timing Requirements For Program Flash

		MIN	NOM	MAX	Unit
$t_{\text{prog(32-bit)}}$	Full word (32-bit) programming time		33	300	μs
$t_{\text{prog(Total)}}$	2M-byte programming time ⁽¹⁾	-40°C to 125°C	17	74	s
		0°C to 60°C, for first 25 cycles	17	25	s
$t_{\text{prog ECC(16-bit)}}$	ECC programming time		33	300	μs
$t_{\text{prog ECC(total)}}$	Total ECC bit programming time (256k-byte)	-40°C to 125°C	4.3	15	s
		0°C to 60°C, for first 25 cycles	4.3	7	s
$t_{\text{erase(sector)}}$	Sector erase time (including compaction)	-40°C to 125°C	2	15	s
		0°C to 60°C, for first 25 cycles	1.5	10	s
$t_{\text{erase(bank)}}$	Bank erase time (including compaction), 0C to 60C, for first 25 cycles	Bank 0	7.5	20	s
		Bank 1	5.5	12	s
		Bank 2	5.5	12	s
		Bank 3	5.5	12	s
t_{wec}	Write/erase cycles at $T_A = 125^\circ\text{C}$ with 15 year Data Retention requirement			1000	cycles

(1) This programming time includes overhead of state machine, but does not include data transfer time.

7.8 SPI Master Mode Timing Parameters

7.8.1 SPI Master Mode External Timing Parameters (CLOCK PHASE = 0, SPICLK = output, SPISIMO = output, and SPISOMI = input)

Table 7-11. SPI Master Mode External Timing Parameters⁽¹⁾⁽²⁾⁽³⁾

NO.			MIN	MAX	Unit
1	$t_{c(SPC)M}$	Cycle time, SPICLK ⁽⁴⁾	50	256tc(VCLK)	ns
2 ⁽⁵⁾	$t_{w(SPCH)M}$	Pulse duration, SPICLK high (clock polarity = 0)	$0.5tc(SPC)M - 3 - tr$	$0.5tc(SPC)M + 5$	ns
	$t_{w(SPCL)M}$	Pulse duration, SPICLK low (clock polarity = 1)	$0.5tc(SPC)M - 3 - tf$	$0.5tc(SPC)M + 5$	
3 ⁽⁵⁾	$t_{w(SPCL)M}$	Pulse duration, SPICLK low (clock polarity = 0)	$0.5tc(SPC)M - 3 - tf$	$0.5tc(SPC)M + 5$	ns
	$t_{w(SPCH)M}$	Pulse duration, SPICLK high (clock polarity = 1)	$0.5tc(SPC)M - 3 - tr$	$0.5tc(SPC)M + 5$	
4 ⁽⁵⁾	$t_{d(SPCH-SIMO)M}$	Delay time, SPISIMO valid before SPICLK low (clock polarity = 0)	$0.5tc(SPC)M - 10$		ns
	$t_{d(SPCL-SIMO)M}$	Delay time, SPISIMO valid before SPICLK high (clock polarity = 1)	$0.5tc(SPC)M - 10$		
5 ⁽⁵⁾	$t_{v(SPCL-SIMO)M}$	Valid time, SPISIMO data valid after SPICLK low (clock polarity = 0)	$0.5tc(SPC)M - tf(SPC) - 5$		ns
	$t_{v(SPCH-SIMO)M}$	Valid time, SPISIMO data valid after SPICLK high (clock polarity = 1)	$0.5tc(SPC)M - tr(SPC) - 5$		
6 ⁽⁵⁾	$t_{su(SOMI-SPCL)M}$	Setup time, SPISOMI before SPICLK low (clock polarity = 0)	$tf(SPC)$		ns
	$t_{su(SOMI-SPCH)M}$	Setup time, SPISOMI before SPICLK high (clock polarity = 1)	$tr(SPC) + 4$		
7 ⁽⁵⁾	$t_{h(SPCL-SOMI)M}$	Hold time, SPISOMI data valid after SPICLK low (clock polarity = 0)	10		ns
	$t_{h(SPCH-SOMI)M}$	Hold time, SPISOMI data valid after SPICLK high (clock polarity = 1)	10		
8 ⁽⁶⁾	$t_{C2TDELAY}$	Setup time CS active until SPICLK high (clock polarity = 0)	$C2TDELAY * t_{c(VCLK)} + 2 * t_{c(VCLK)} - t_{f(SPICS)} + t_{f(SPC)}$		ns
		Setup time CS active until SPICLK low (clock polarity = 1)	$C2TDELAY * t_{c(VCLK)} + 2 * t_{c(VCLK)} - t_{f(SPICS)} + t_{f(SPC)}$		ns
9 ⁽⁶⁾	$t_{T2CDELAY}$	Hold time SPICLK low CS until inactive (clock polarity = 0)		$0.5 * t_{c(SPC)M} + T2CDELAY * t_{c(VCLK)} + t_{c(VCLK)} - t_{f(SPC)} + t_{f(SPICS)}$	ns
		Hold time SPICLK high until CS inactive (clock polarity = 1)		$0.5 * t_{c(SPC)M} + T2CDELAY * t_{c(VCLK)} + t_{c(VCLK)} - t_{f(SPC)} + t_{f(SPICS)}$	ns
10	t_{SPIENA}	SPIENAn Sample point	$(C2TDELAY + 1) * t_{c(VCLK)} - t_{f(SPICS)}$	$(C2TDELAY + 1) * t_{c(VCLK)}$	ns
11	$t_{SPIENAW}$	SPIENAn Sample point from write to buffer		$(C2TDELAY + 2) * t_{c(VCLK)}$	ns

(1) The MASTER bit (SPIGCR1.0) is set and the CLOCK PHASE bit (SPIFMTx.16) is set.

(2) $tc(VCLK) = \text{interface clock cycle time} = 1 / f(VCLK)$

(3) For rise and fall timings, see the "switching characteristics for output timings versus load capacitance" table.

(4) When the SPI is in Master mode, the following must be true:

For PS values from 1 to 255: $tc(SPC)M \geq (PS + 1)tc(VCLK) \geq 50$ ns, where PS is the prescale value set in the SPIFMTx.[15:8] register bits.

For PS values of 0: $tc(SPC)M = 2tc(VCLK) \geq 50$ ns. The external load on the SPICLK pin must be less than 60pF.

(5) The active edge of the SPICLK signal referenced is controlled by the CLOCK POLARITY bit (SPIFMTx.17).

(6) C2TDELAY and T2CDELAY are programmed in the SPIDELAY register

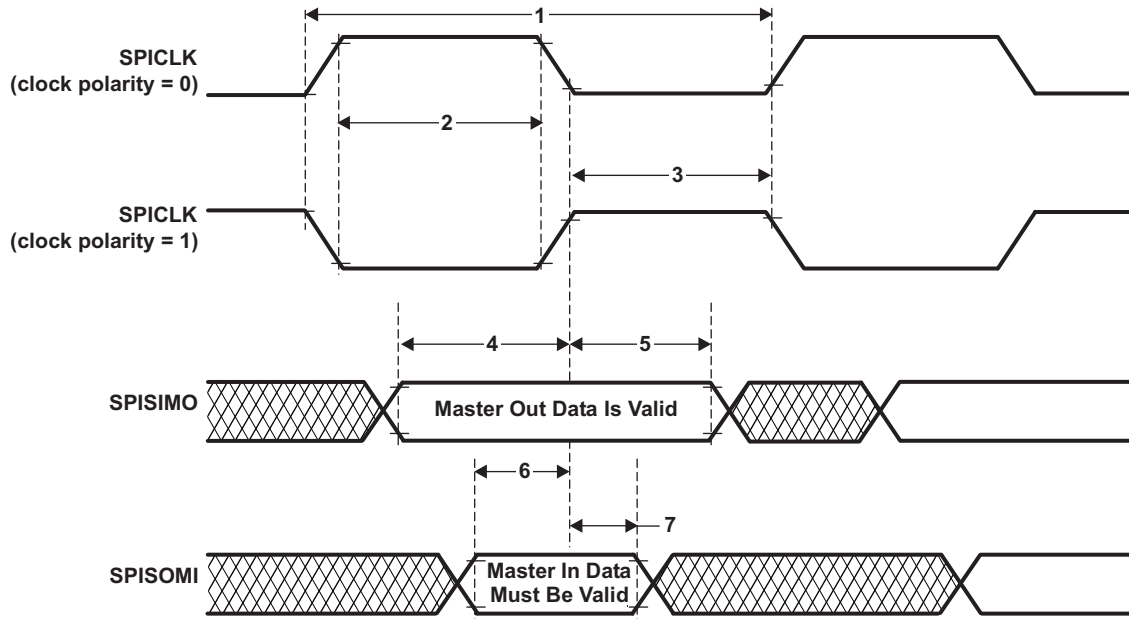

Figure 7-9. SPI Master Mode External Timing (CLOCK PHASE = 0)

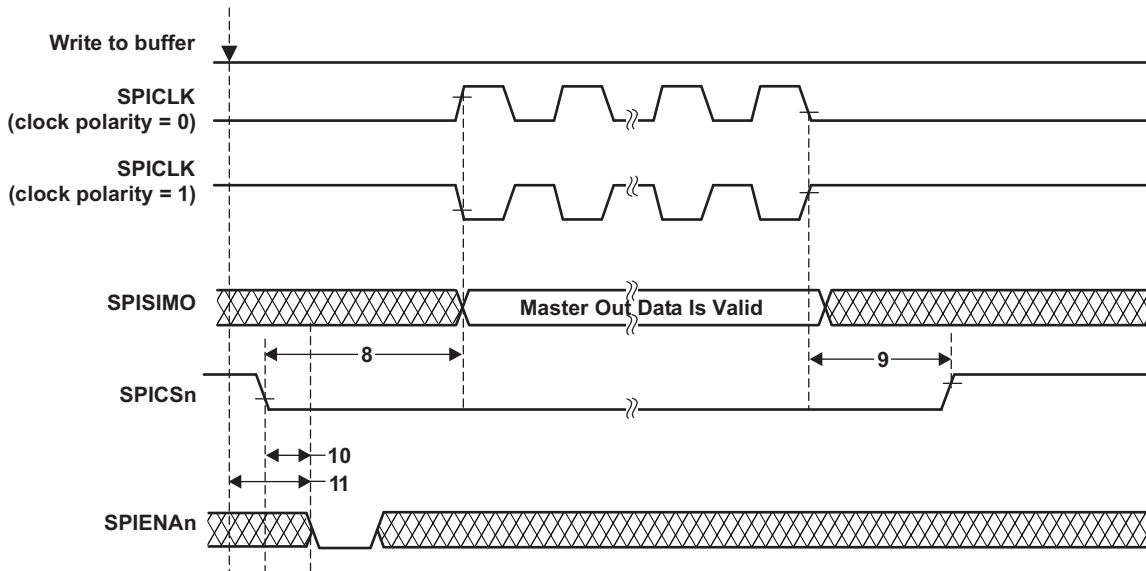

Figure 7-10. SPI Master Mode Chip Select timing (CLOCK PHASE = 0)

PRODUCT PREVIEW

7.8.2 SPI Master Mode External Timing Parameters (CLOCK PHASE = 1, SPICLK = output, SPISIMO = output, and SPISOMI = input)⁽⁷⁾⁽⁸⁾⁽⁹⁾

Table 7-12. SPI Master Mode External Timing Parameters

NO.			MIN	MAX	Unit
1	$t_{c(SPC)M}$	Cycle time, SPICLK ⁽¹⁾	50	256tc(VCLK)	ns
2 ⁽²⁾	$t_{w(SPCH)M}$	Pulse duration, SPICLK high (clock polarity = 0)	$0.5tc(SPC)M - 3 - tr$	$0.5tc(SPC)M + 5$	ns
	$t_{w(SPCL)M}$	Pulse duration, SPICLK low (clock polarity = 1)	$0.5tc(SPC)M - 3 - tf$	$0.5tc(SPC)M + 5$	
3 ⁽²⁾	$t_{w(SPCL)M}$	Pulse duration, SPICLK low (clock polarity = 0)	$0.5tc(SPC)M - 3 - tr$	$0.5tc(SPC)M + 5$	ns
	$t_{w(SPCH)M}$	Pulse duration, SPICLK high (clock polarity = 1)	$0.5tc(SPC)M - 3 - tf$	$0.5tc(SPC)M + 5$	
4 ⁽²⁾	$t_{v(SIMO-SPCH)M}$	Valid time, SPICLK high after SPISIMO data valid(clock polarity = 0)	$0.5tc(SPC)M - 15$		ns
	$t_{v(SIMO-SPCL)M}$	Valid time, SPICLK low after SPISIMO data valid (clock polarity = 1)	$0.5tc(SPC)M - 15$		
5 ⁽²⁾	$t_{v(SPCH-SIMO)M}$	Valid time, SPISIMO data valid after SPICLK high(clock polarity = 0)	$0.5tc(SPC)M - tr(SPC)$		ns
	$t_{v(SPCL-SIMO)M}$	Valid time, SPISIMO data valid after SPICLK low(clock polarity = 1)	$0.5tc(SPC)M - tf(SPC)$		
6 ⁽²⁾	$t_{su(SOMI-SPCH)M}$	Setup time, SPISOMI before SPICLK high (clock polarity = 0)	4		ns
	$t_{su(SOMI-SPCL)M}$	Setup time, SPISOMI before SPICLK low (clock polarity = 1)	4		
7 ⁽²⁾	$t_{v(SPCH-SOMI)M}$	Valid time, SPISOMI data valid after SPICLK high (clock polarity = 0)	6		ns
	$t_{v(SPCL-SOMI)M}$	Valid time, SPISOMI data valid after SPICLK low (clock polarity = 1)	6		
8 ⁽³⁾	$t_{C2TDELAY}$	Setup time CS active until SPICLK high (clock polarity = 0)	$0.5 * t_{c(SPC)M} + C2TDELAY * t_{c(VCLK)} + 2 * t_{c(VCLK)} - t_{f(SPICS)} + t_{f(SPC)}$		ns
		Setup time CS active until SPICLK low (clock polarity = 1)	$0.5 * t_{c(SPC)M} + C2TDELAY * t_{c(VCLK)} + 2 * t_{c(VCLK)} - t_{f(SPICS)} + t_{f(SPC)}$		ns
9 ⁽³⁾	$t_{T2CDELAY}$	Hold time SPICLK low CS until inactive (clock polarity = 0)		$T2CDELAY * t_{c(VCLK)} + t_{c(VCLK)} - t_{f(SPC)} + t_{f(SPICS)}$	ns
		Hold time SPICLK high until CS inactive (clock polarity = 1)		$T2CDELAY * t_{c(VCLK)} + t_{c(VCLK)} - t_{f(SPC)} + t_{f(SPICS)}$	ns
10	t_{SPIENA}	SPIENAn Sample Point	$(C2TDELAY+1) * t_{c(VCLK)} - t_{f(SPICS)}$	$(C2TDELAY+1) * t_{c(VCLK)}$	ns
11	$t_{SPIENAW}$	SPIENAn Sample point from write to buffer		$(C2TDELAY+2) * t_{c(VCLK)}$	ns

- (7) The MASTER bit (SPIGCR1.0) is set and the CLOCK PHASE bit (SPIFMTx.16) is set.
- (8) $tc(VCLK)$ = interface clock cycle time = $1 / f(VCLK)$
- (9) For rise and fall timings, see the "switching characteristics for output timings versus load capacitance" table.
- (1) When the SPI is in Master mode, the following must be true:
For PS values from 1 to 255: $tc(SPC)M \geq (PS + 1)tc(VCLK) \geq 50$ ns, where PS is the prescale value set in the SPIFMTx.[15:8] register bits.
For PS values of 0: $tc(SPC)M = 2tc(VCLK) \geq 50$ ns. The external load on the SPICLK pin must be less than 60pF.
- (2) The active edge of the SPICLK signal referenced is controlled by the CLOCK POLARITY bit (SPIFMTx.17).
- (3) C2TDELAY and T2CDELAY are programmed in the SPIDELAY register

PRODUCT PREVIEW

7.9 SPI Slave Mode Timing Parameters

7.9.1 SPI Slave Mode External Timing Parameters (CLOCK PHASE = 0, SPICLK = input, SPISIMO = input, and SPISOMI = output)⁽⁴⁾⁽⁵⁾⁽⁶⁾⁽⁷⁾

Table 7-13. SPI Slave Mode External Timing Parameters

NO.			MIN	MAX	Unit
1	$t_{c(SPC)S}$	Cycle time, SPICLK ⁽¹⁾	50	256tc(VCLK)	ns
2 ⁽²⁾	$t_{w(SPCH)S}$	Pulse duration, SPICLK high(clock polarity = 0)	$0.5tc(SPC)S - 0.25tc(VCLK)$	$0.5tc(SPC)S + 0.25tc(VCLK)$	ns
	$t_{w(SPCL)S}$	Pulse duration, SPICLK low(clock polarity = 1)	$0.5tc(SPC)S - 0.25tc(VCLK)$	$0.5tc(SPC)S + 0.25tc(VCLK)$	
3 ⁽²⁾	$t_{w(SPCL)S}$	Pulse duration, SPICLK low(clock polarity = 0)	$0.5tc(SPC)S - 0.25tc(VCLK)$	$0.5tc(SPC)S + 0.25tc(VCLK)$	ns
	$t_{w(SPCH)S}$	Pulse duration, SPICLK high(clock polarity = 1)	$0.5tc(SPC)S - 0.25tc(VCLK)$	$0.5tc(SPC)S + 0.25tc(VCLK)$	
4 ⁽²⁾	$t_{d(SPCH-SOMI)S}$	Delay time, SPISOMI valid after SPICLK high (clock polarity = 0)		trf(SOMI) + 15	ns
	$t_{d(SPCL-SOMI)S}$	Delay time, SPISOMI valid after SPICLK low (clock polarity = 1)		trf(SOMI) + 15	
5 ⁽²⁾	$t_{H(SPCH-SOMI)S}$	Hold time, SPISOMI data valid after SPICLK high (clock polarity = 0)	0		ns
	$t_{H(SPCL-SOMI)S}$	Hold time, SPISOMI data valid after SPICLK low (clock polarity = 1)	0		
6 ⁽²⁾	$t_{su(SIMO-SPCL)S}$	Setup time, SPISIMO before SPICLK low(clock polarity = 0)	4		ns
	$t_{su(SIMO-SPCH)S}$	Setup time, SPISIMO before SPICLK high(clock polarity = 1)	4		
7 ⁽²⁾	$t_{h(SPCL-SIMO)S}$	Hold time, SPISIMO data valid after SPICLK low (clock polarity = 0)	6		ns
	$t_{h(SPCH-SIMO)S}$	Hold time, SPISIMO data valid after SPICLK high (clock polarity = 1)	6		
8	$t_{d(SPCL-SENAH)S}$	Delay time, SPIENAn high after last SPICLK low (clock polarity = 0)	1.5tc(VCLK)	2.5tc(VCLK)+tr(ENAn)	ns
	$t_{d(SPCH-SENAH)S}$	Delay time, SPIENAn high after last SPICLK high (clock polarity = 1)	1.5tc(VCLK)	2.5tc(VCLK)+tr(ENAn)	
9	$t_{d(SCSL-SENAL)S}$	Delay time, SPIENAn low after SPICSn low (if new data has been written to the SPI buffer)		tf(ENAn)+6	ns

(4) The MASTER bit (SPIGCR1.0) is set and the CLOCK PHASE bit (SPIFMTx.16) is set.

(5) If the SPI is in slave mode, the following must be true: $t_{c(SPC)S} \geq (PS + 1) t_{c(VCLK)}$, where PS = prescale value set in SPIFMTx.[15:8].

(6) $t_{c(VCLK)}$ = interface clock cycle time = $1 / f_{(VCLK)}$

(7) For rise and fall timings, see the "switching characteristics for output timings versus load capacitance" table.

(1) When the SPI is in Slave mode, the following must be true:

For PS values from 1 to 255: $t_{c(SPC)S} \geq (PS + 1)t_{c(VCLK)} \geq 50$ ns, where PS is the prescale value set in the SPIFMTx.[15:8] register bits.

For PS values of 0: $t_{c(SPC)S} = 2t_{c(VCLK)} \geq 50$ ns.

(2) The active edge of the SPICLK signal referenced is controlled by the CLOCK POLARITY bit (SPIFMTx.17).

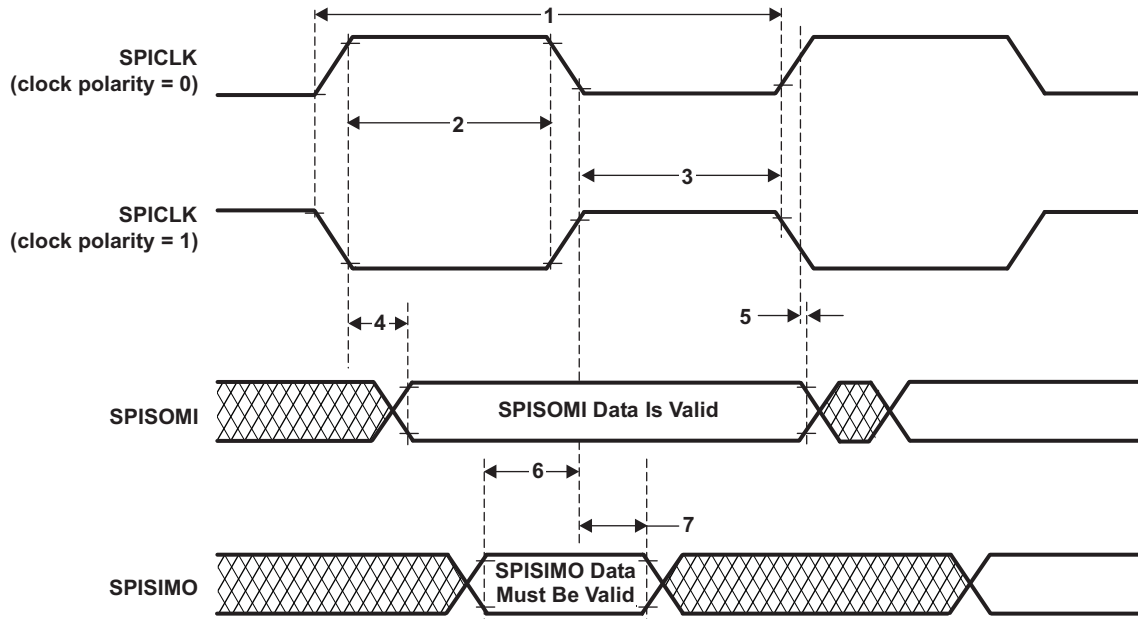

Figure 7-13. SPI Slave Mode External Timing (CLOCK PHASE = 0)

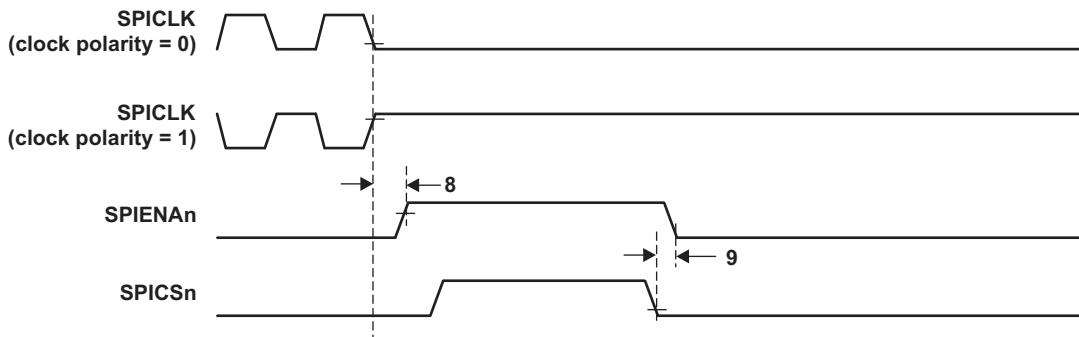

Figure 7-14. SPI Slave Mode Enable Timing (CLOCK PHASE = 0)

7.9.2 SPI Slave Mode External Timing Parameters (CLOCK PHASE = 1, SPICLK = input, SPISIMO = input, and SPISOMI = output)⁽³⁾⁽⁴⁾⁽⁵⁾⁽⁶⁾

Table 7-14. SPI Slave Mode External Timing Parameters

NO.			MIN	MAX	Unit
1	$t_{c(SPC)S}$	Cycle time, SPICLK ⁽¹⁾	50	256tc(VCLK)	ns
2 ⁽²⁾	$t_w(SPCH)S$	Pulse duration, SPICLK high (clock polarity = 0)	0.5tc(SPC)S – 0.25tc(VCLK)	0.5tc(SPC)S + 0.25tc(VCLK)	ns
	$t_w(SPCL)S$	Pulse duration, SPICLK low (clock polarity = 1)	0.5tc(SPC)S – 0.25tc(VCLK)	0.5tc(SPC)S + 0.25tc(VCLK)	
3 ⁽²⁾	$t_w(SPCL)S$	Pulse duration, SPICLK low (clock polarity = 0)	0.5tc(SPC)S – 0.25tc(VCLK)	0.5tc(SPC)S + 0.25tc(VCLK)	ns
	$t_w(SPCH)S$	Pulse duration, SPICLK high (clock polarity = 1)	0.5tc(SPC)S – 0.25tc(VCLK)	0.5tc(SPC)S + 0.25tc(VCLK)	
4 ⁽²⁾	$t_d(SOMI-SPCL)S$	Delay time, SPISOMI data valid after SPICLK low (clock polarity = 0)		trf(SOMI)+15	ns
	$t_d(SOMI-SPCH)S$	Delay time, SPISOMI data valid after SPICLK high (clock polarity = 1)		trf(SOMI)+15	
5 ⁽²⁾	$t_H(SPCL-SOMI)S$	Hold time, SPISOMI data valid after SPICLK high (clock polarity = 0)	0		ns
	$t_H(SPCH-SOMI)S$	Hold time, SPISOMI data valid after SPICLK low (clock polarity = 1)	0		
6 ⁽²⁾	$t_{su}(SIMO-SPCH)S$	Setup time, SPISIMO before SPICLK high (clock polarity = 0)	4		ns
	$t_{su}(SIMO-SPCL)S$	Setup time, SPISIMO before SPICLK low (clock polarity = 1)	4		
7 ⁽²⁾	$t_v(SPCH-SIMO)S$	High time, SPISIMO data valid after SPICLK high (clock polarity = 0)	6		ns
	$t_v(SPCL-SIMO)S$	High time, SPISIMO data valid after SPICLK low (clock polarity = 1)	6		
8	$t_d(SPCH-SENAn)S$	Delay time, SPIENAn high after last SPICLK high (clock polarity = 0)	1.5tc(VCLK)	2.5tc(VCLK)+tr(ENAn)	ns
	$t_d(SPCL-SENAn)S$	Delay time, SPIENAn high after last SPICLK low (clock polarity = 1)	1.5tc(VCLK)	2.5tc(VCLK)+tr(ENAn)	
9	$t_d(SCSL-SENAL)S$	Delay time, SPIENAn low after SPICSn low (if new data has been written to the SPI buffer)		tf(ENAn)+6	ns
10	$t_d(SCSL-SOMI)S$	Delay time, SOMI valid after SPICSn low (if new data has been written to the SPI buffer)		trf(SOMI)+6	ns

- (3) The MASTER bit (SPIGCR1.0) is set and the CLOCK PHASE bit (SPIFMTx.16) is set.
- (4) If the SPI is in slave mode, the following must be true: $t_{c(SPC)S} \geq (PS + 1) t_{c(VCLK)}$, where PS = prescale value set in SPIFMTx.[15:8].
- (5) $t_{c(VCLK)}$ = interface clock cycle time = $1 / f_{(VCLK)}$
- (6) For rise and fall timings, see the "switching characteristics for output timings versus load capacitance" table.
- (1) When the SPI is in Slave mode, the following must be true:
For PS values from 1 to 255: $t_{c(SPC)S} \geq (PS + 1)t_{c(VCLK)} \geq 50$ ns, where PS is the prescale value set in the SPIFMTx.[15:8] register bits.
For PS values of 0: $t_{c(SPC)S} = 2t_{c(VCLK)} \geq 50$ ns.
- (2) The active edge of the SPICLK signal referenced is controlled by the CLOCK POLARITY bit (SPIFMTx.17).

PRODUCT PREVIEW

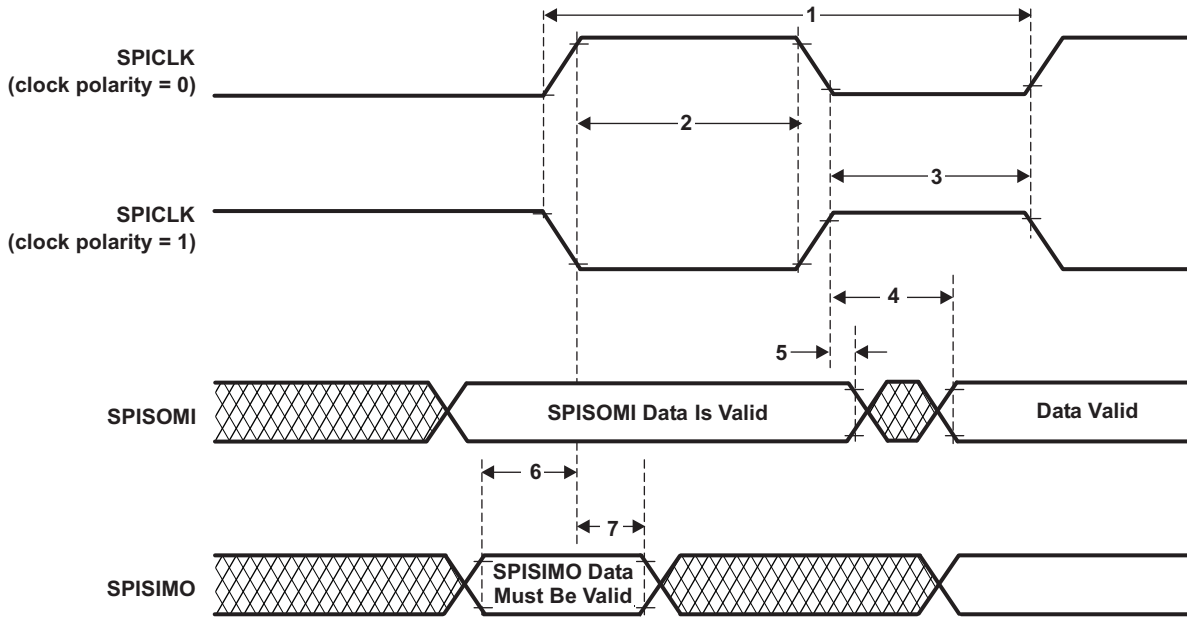

Figure 7-15. SPI Slave Mode External Timing (CLOCK PHASE = 1)

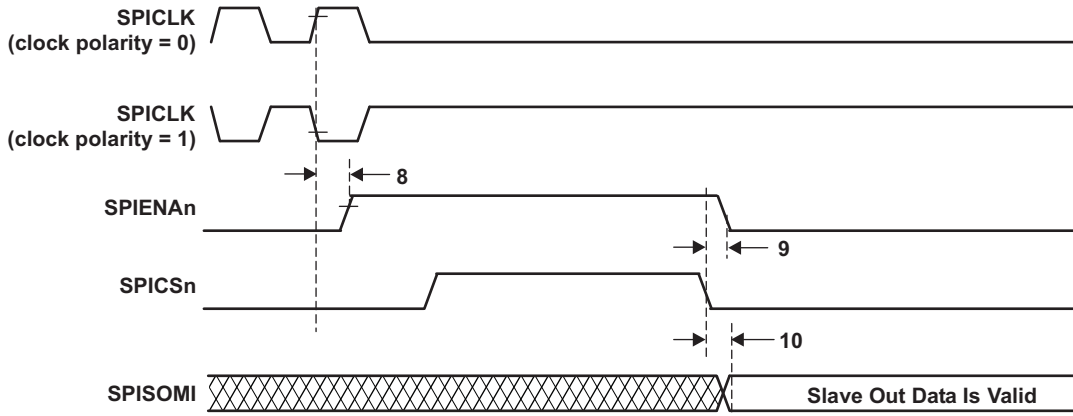

Figure 7-16. SPI Slave Mode Enable Timing (CLOCK PHASE = 1)

7.10 CAN Controller Mode Timings

7.10.1 Dynamic Characteristics For The CANnTX And CANnRX Pins

Table 7-15. Dynamic Characteristics For The CANnTX And CANnRX Pins

Parameter		MIN	MAX	Unit
$t_d(\text{CANnTX})$	Delay time, transmit shift register to CANnTX pin ⁽¹⁾		15	ns
$t_d(\text{CANnRX})$	Delay time, CANnRX pin to receive shift register		5	ns

(1) These values do not include rise/fall times of the output buffer.

7.11 Flexray Controller Mode Timings

7.11.1 Jitter Timing

Table 7-16. Jitter Timing

Parameter		MIN	MAX	Unit
t_{Tx1bit}	clock jitter and signal symmetry	98	102	ns
$t_{Tx10bit}$	FlexRay BSS (byte start sequence) to BSS	999	1001	ns
$t_{Tx10bitAvg}$	average over 10000 samples	999.5	1000.5	ns
$t_{RxAsymDelay}$	delay difference between rise and fall from Rx pin to sample point in FlexRay core	-	2.5	ns

7.12 EMIF Timings

Table 7-17. EMIF Read/Write Mode Switching Characteristics⁽¹⁾⁽²⁾

NO	Parameter	Description	MIN	MAX	Unit
Reads and Writes					
1	$t_d(\text{TURNAROUND})$	Turn around time	$(TA + 1) * E - \text{TBD}$	$(TA + 1) * E + \text{TBD}$	ns
Reads					
2	$t_c(\text{EMRCYCLE})$	EMIF read cycle time	$(RS + RST + RH + TA + 4) * E - \text{TBD}$	$(RS + RST + RH + TA + 4) * E + \text{TBD}$	ns
3	$t_{su}(\text{EMCSL-EMOEL})$	Output setup time, $\overline{\text{EMIFCS}}[3:0]$ low to $\overline{\text{EMIFOE}}$ low (SS=0)	$(RS + 1) * E - \text{TBD}$	$(RS + 1) * E + \text{TBD}$	ns
		Output setup time, $\overline{\text{EMIFCS}}[3:0]$ low to $\overline{\text{EMIFOE}}$ low (SS=1)	TBD	TBD	ns
4	$t_h(\text{EMOEH-EMCSH})$	Output hold time, $\overline{\text{EMIFOE}}$ high to $\overline{\text{EMIFCS}}[3:0]$ high (SS=0)	$(RH + 1) * E - \text{TBD}$	$(RH + 1) * E + \text{TBD}$	ns
		Output hold time, $\overline{\text{EMIFOE}}$ high to $\overline{\text{EMIFCS}}[3:0]$ high (SS=1)	TBD	TBD	ns
5	$t_{su}(\text{EMBAV-EMOEL})$	Output setup time, $\overline{\text{EMIFBADD}}[1:0]$ valid to $\overline{\text{EMIFOE}}$ low	$(RS + 1) * E - \text{TBD}$	$(RS + 1) * E + \text{TBD}$	ns
6	$t_h(\text{EMOEH-EMBAIV})$	Output hold time, $\overline{\text{EMIFOE}}$ high to $\overline{\text{EMIFBADD}}[1:0]$ invalid	$(RH + 1) * E - \text{TBD}$	$(RH + 1) * E + \text{TBD}$	ns
7	$t_{su}(\text{EMAV-EMOEL})$	Output setup time, $\overline{\text{EMIFADD}}[21:0]$ valid to $\overline{\text{EMIFOE}}$ low	$(RS + 1) * E - \text{TBD}$	$(RS + 1) * E + \text{TBD}$	ns
8	$t_h(\text{EMOEH-EMAIIV})$	Output hold time, $\overline{\text{EMIFOE}}$ high to $\overline{\text{EMIFADD}}[21:0]$ invalid	$(RH + 1) * E - \text{TBD}$	$(RH + 1) * E + \text{TBD}$	ns
9	$t_w(\text{EMOEL})$	$\overline{\text{EMIFOE}}$ active low width	$(RST + 1) * E - \text{TBD}$	$(RST + 1) * E + \text{TBD}$	ns
10	$t_{su}(\text{EMDV-EMOEH})$	Setup time, $\overline{\text{EMIFD}}[15:0]$ valid before $\overline{\text{EMIFOE}}$ high	TBD		ns
11	$t_h(\text{EMOEH-EMDV})$	Hold time, $\overline{\text{EMIFD}}[15:0]$ valid after $\overline{\text{EMIFOE}}$ high	TBD		
Writes					
12	$t_c(\text{EMWCYCLE})$	EMIF write cycle time	$(WS + WST + WH + TA + 4) * E - \text{TBD}$	$(WS + WST + WH + TA + 4) * E + \text{TBD}$	ns
13	$t_{su}(\text{EMCSL-EMWEL})$	Output setup time, $\overline{\text{EMIFCS}}[3:0]$ low to $\overline{\text{EMIFWE}}$ low (SS=0)	$(WS + 1) * E - \text{TBD}$	$(WS + 1) * E + \text{TBD}$	ns
		Output setup time, $\overline{\text{EMIFCS}}[3:0]$ low to $\overline{\text{EMIFWE}}$ low (SS=1)	TBD	TBD	ns
14	$t_h(\text{EMWEH-EMCSH})$	Output hold time, $\overline{\text{EMIFWE}}$ high to $\overline{\text{EMIFCS}}[3:0]$ high (SS=0)	$(WH + 1) * E - \text{TBD}$	$(WH + 1) * E + \text{TBD}$	ns
		Output hold time, $\overline{\text{EMIFWE}}$ high to $\overline{\text{EMIFCS}}[3:0]$ high (SS=1)	TBD	TBD	ns
15	$t_{su}(\text{EMBAV-EMWEL})$	Output setup time, $\overline{\text{EMIFBADD}}[1:0]$ valid to $\overline{\text{EMIFWE}}$ low	$(WS + 1) * E - \text{TBD}$	$(WS + 1) * E + \text{TBD}$	ns
16	$t_h(\text{EMWEH-EMBAIV})$	Output hold time, $\overline{\text{EMIFWE}}$ high to $\overline{\text{EMBADD}}[1:0]$ invalid	$(WH + 1) * E - \text{TBD}$	$(WH + 1) * E + \text{TBD}$	ns
17	$t_{su}(\text{EMAV-EMWEL})$	Output setup time, $\overline{\text{EMIFADD}}[21:0]$ valid to $\overline{\text{EMIFWE}}$ low	$(WS + 1) * E - \text{TBD}$	$(WS + 1) * E + \text{TBD}$	ns
18	$t_h(\text{EMWEH-EMAIIV})$	Output hold time, $\overline{\text{EMIFWE}}$ high to $\overline{\text{EMIFADD}}[21:0]$ invalid	$(WH + 1) * E - \text{TBD}$	$(WH + 1) * E + \text{TBD}$	ns
19	$t_w(\text{EMWEL})$	$\overline{\text{EMIFWE}}$ active low width	$(WST + 1) * E - \text{TBD}$	$(WST + 1) * E + \text{TBD}$	ns

- (1) RS = Read setup, RST = Read Strobe, RH = Read Hold, WS = Write Setup, WST = Write Strobe, WH = Write Hold, TA = Turn Around, SS= Strobe Select Mode
(2) E = VCLK period in ns.

Table 7-17. EMIF Read/Write Mode Switching Characteristics ^{(1) (2)} (continued)

NO	Parameter	Description	MIN	MAX	Unit
20	$t_{su}(EMDV-ENWEL)$	Output setup time, EMIFD[15:0] valid to \overline{EMIFWE} low	$(WS + 1) * E - TBD$	$(WS + 1) * E + TBD$	ns
21	$t_h(EMWEH-EMDIV)$	Output hold time, EMIFD[15:0] valid after EMIFWE high	$(WH + 1) * E - TBD$	$(WH + 1) * E + TBD$	ns

7.12.1 Read Timing (Asynchronous RAM)

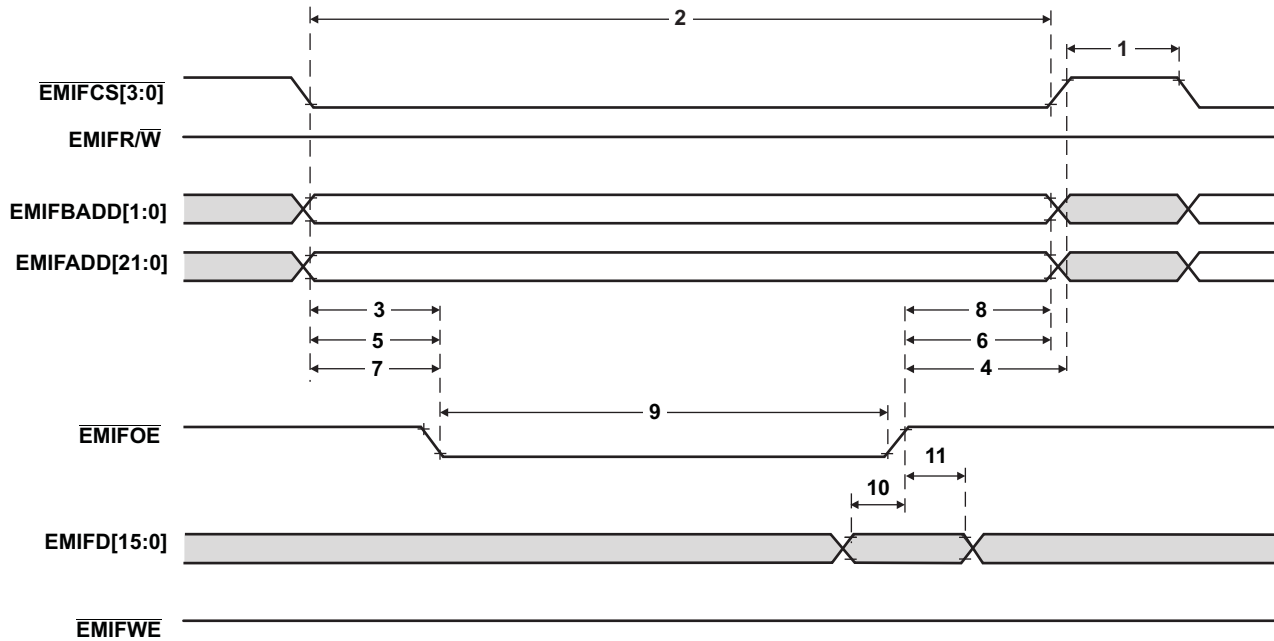

Figure 7-17. Asynchronous Memory Read Timing for EMIF

7.12.2 Write Timing (Asynchronous RAM)

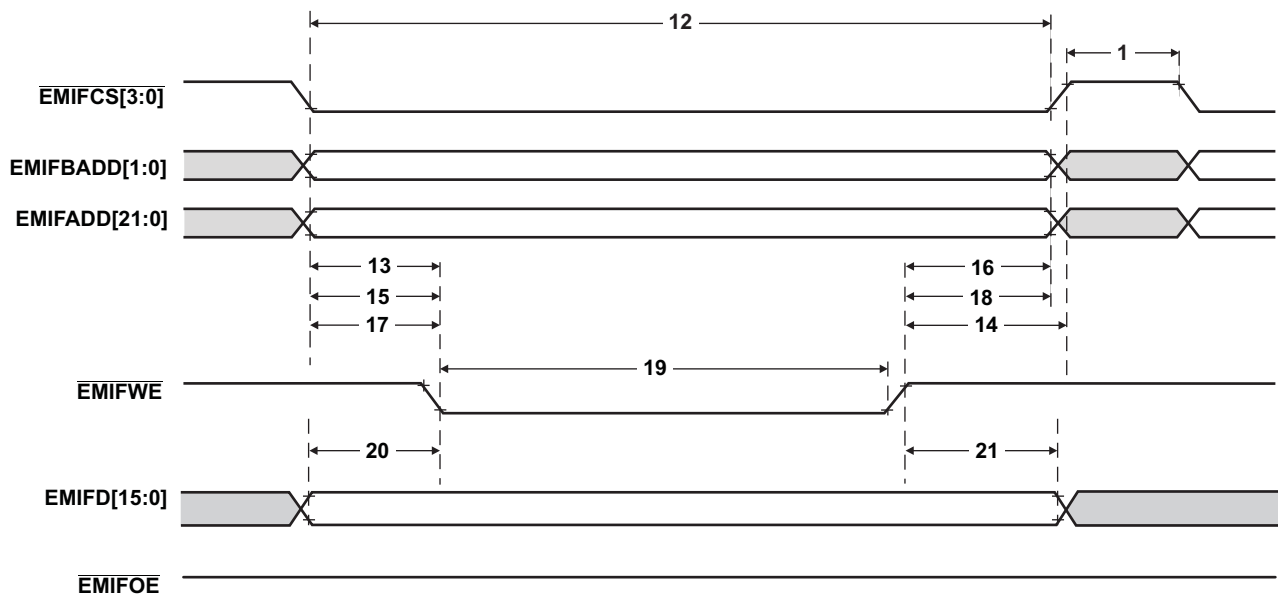

Figure 7-18. Asynchronous Memory Write Timing for EMIF

PRODUCT PREVIEW

7.13 ETM Timings

7.13.1 ETMTRACECLK Timing

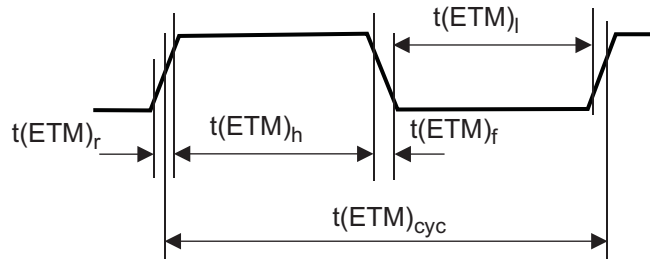

Figure 7-19. ETMTRACECLK Timing

Table 7-18. ETMTRACECLK Timing

Parameter	Minimum	Maximum	Description
$f(ETM)_{cyc}$		45MHz	Clock frequency
$t(ETM)_{cyc}$	22.22ns		Clock period
$t(ETM)_l$	2ns		Low pulse width
$t(ETM)_h$	2ns		High pulse width
$t(ETM)_r$	3ns		Clock and data rise time
$t(ETM)_f$	3ns		Clock and data fall time

7.13.2 ETMDATA Timing

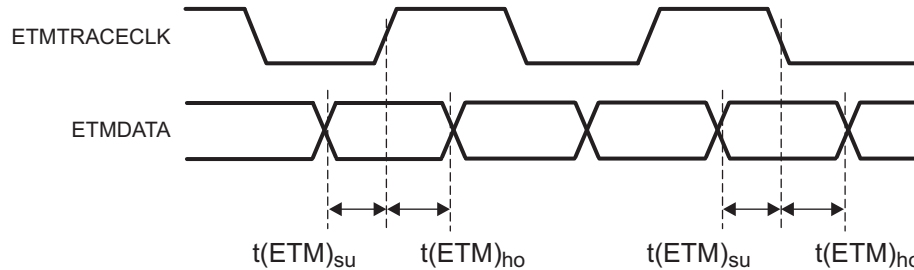

Figure 7-20. ETMDATA Timing

Table 7-19. ETMDATA Timing

Parameter	Minimum	Maximum	Description
$t(ETM)_{su}$		2.5ns	Data setup time
$t(ETM)_{ho}$	1.5ns		Data hold time

Note: The ETMTRACECLK and ETMDATA timing is based on a 50pF load.

7.14 RTP Timings

7.14.1 RTPCLK Timing

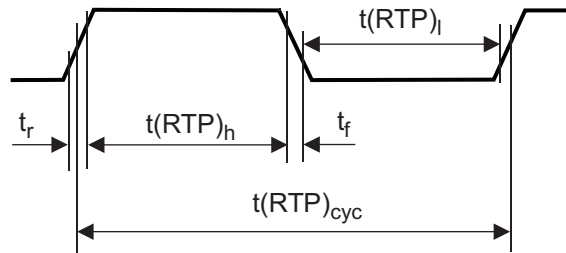

Figure 7-21. RTPCLK Timing

Table 7-20. RTPCLK Timing

Parameter	Minimum	Description
$t(\text{RTP})_{\text{cyc}}$	$t_{\text{c}}(\text{HCLK})$	Clock period (depending on HCLK divide ratio)
$t(\text{RTP})_{\text{h}}$	$(t(\text{RTP})_{\text{cyc}}/2) - ((t_{\text{r}}+t_{\text{f}})/2)$	High pulse width (depending on HCLK divide ratio and load on pin)
$t(\text{RTP})_{\text{l}}$	$(t(\text{RTP})_{\text{cyc}}/2) - ((t_{\text{r}}+t_{\text{f}})/2)$	Low pulse width (depending on HCLK divide ratio and load on pin)

7.14.2 RTPDATA Timing

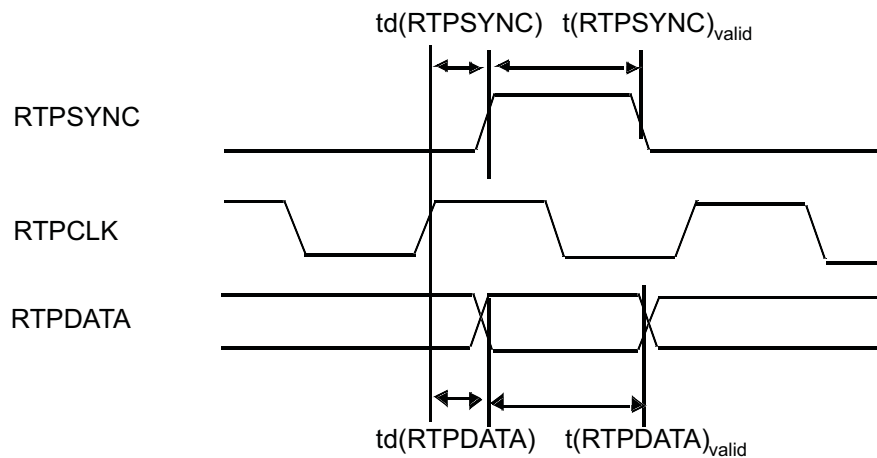

Figure 7-22. RTPDATA Timing

Table 7-21. RTPDATA Timing

Parameter	Minimum	Description
$t_{\text{d}}(\text{RTPSYNC})$	3ns	RTP SYNC delay time
$t(\text{RTP})_{\text{svalid}}$	2ns	RTP SYNC valid
$t_{\text{d}}(\text{RTPDATA})$	3ns	RTP DATA delay time
$t(\text{RTP})_{\text{dvalid}}$	2ns	SYNC hold time

7.14.3 RTPENABLE Timing

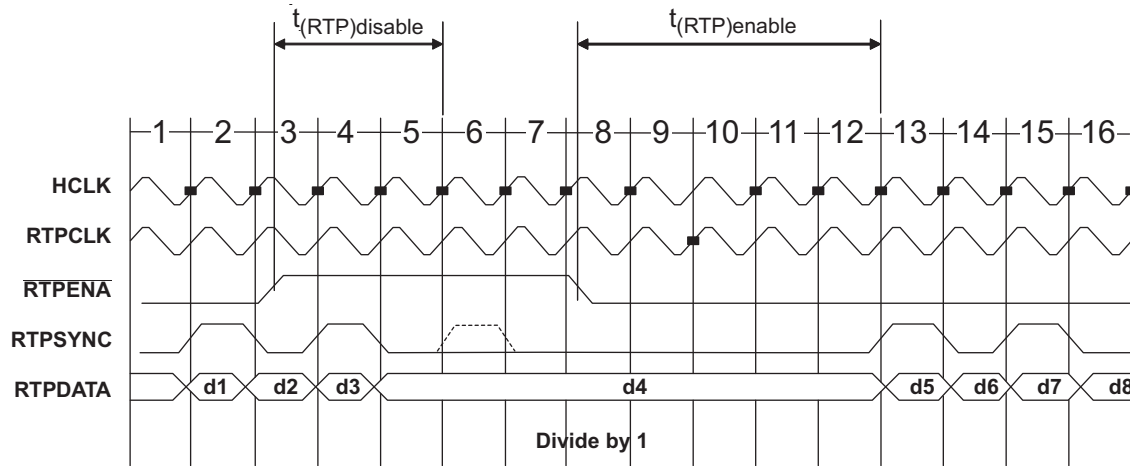

Figure 7-23. RTPENABLE Timing

Table 7-22. RTPENABLE Timing

Parameter	Minimum	Maximum	Description
$t_{(RTP)disable}$	$3t_{c(HCLK)} + t_{r(RTPSYNC)} + 12ns$		time \overline{RTPENA} must go high before what would be the next RTPSYNC, to guarantee delaying the next packet
$t_{(RTP)enable}$	$4t_{c(HCLK)} + t_{r(RTPSYNC)}$	$5t_{c(HCLK)} + t_{r(RTPSYNC)} + 12ns$	time after \overline{RTPENA} goes low before a packet that has been halted, resumes

PRODUCT PREVIEW

7.15 DMM Timings

7.15.1 DMMCLK Timing

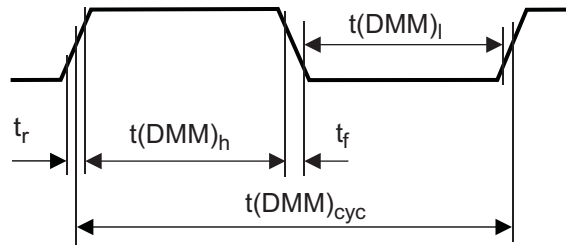

Figure 7-24. DMMCLK Timing

Table 7-23. DMMCLK Timing

Parameter	Minimum	Description
$t(\text{DMM})_{\text{cyc}}$	$t_{\text{c}}(\text{HCLK}) * 2$	Clock period (depending on HCLK divide ratio)
$t(\text{DMM})_h$	$(t(\text{DMM})_{\text{cyc}}/2) - ((t_r+t_f)/2)$	High pulse width (depending on HCLK divide ratio)
$t(\text{DMM})_l$	$(t(\text{DMM})_{\text{cyc}}/2) - ((t_r+t_f)/2)$	Low pulse width (depending on HCLK divide ratio)

7.15.2 DMMDATA Timing

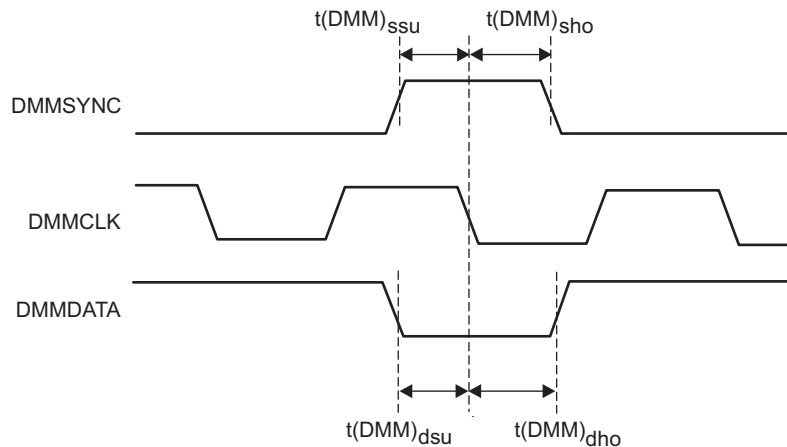

Figure 7-25. DMMDATA Timing

Table 7-24. DMMDATA Timing

Parameter	Minimum	Description
$t(\text{DMM})_{\text{ssu}}$	2 ns	SYNC active to clk falling edge setup time
$t(\text{DMM})_{\text{sho}}$	3ns	clk falling edge to SYNC deactive hold time
$t(\text{DMM})_{\text{dsu}}$	2ns	DATA to clk falling edge setup time
$t(\text{DMM})_{\text{dho}}$	3ns	clk falling edge to DATA hold time

7.15.3 DMMENA Timing

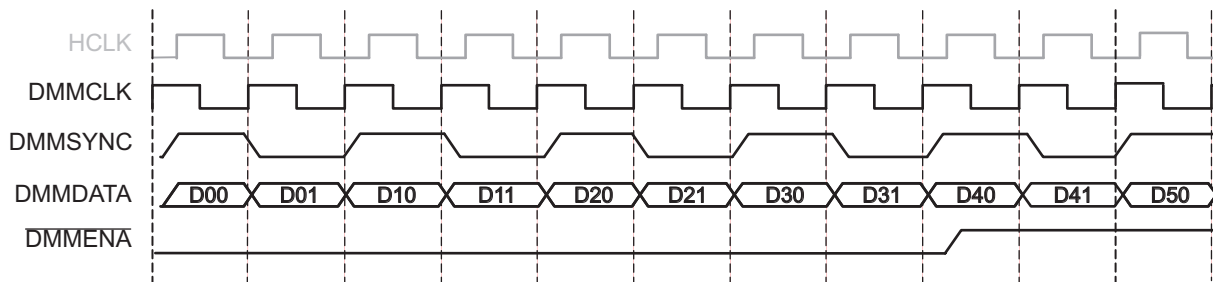

Figure 7-26. DMMENA Timing

The above figure shows a case with 1 DMM packet per 2 DMMCLK cycles (Mode = Direct Data Mode, data width = 8, portwidth = 4) where none of the packets received by the DMM are sent out, leading to filling up of the internal buffers. The DMMENA signal is shown asserted, after the first two packets have been received and synchronized to the HCLK domain. Here, the DMM has the capacity to accept packets D4, D5, D6, D7. Packet D8 would result in an overflow. Once DMMENA is asserted, the DMM expects to stop receiving packets after 4 HCLK cycles; once DMMENA is de-asserted, the DMM can handle packets immediately (after 0 HCLK cycles).

7.16 MibADC

7.16.1 MibADC

The multibuffered A-to-D converter (MibADC) has a separate power bus for its analog circuitry that enhances the A-to-D performance by preventing digital switching noise on the logic circuitry which could be present on VSS and VCC from coupling into the A-to-D analog stage. All A-to-D specifications are given with respect to ADREFLO unless otherwise noted.

Table 7-25. MibADC

Resolution	12 bits (4096 values)
Monotonic	Assured
Output conversion ϕ code	00h to FFFh [00 for $V_{AI} \leq AD_{REFLO}$; FFF for $V_{AI} \geq AD_{REFHI}$]

7.16.2 MibADC Recommended Operating Conditions

Table 7-26. MibADC Recommended Operating Conditions⁽¹⁾

		MIN	MAX	UNIT
AD _{REFHI}	A-to-D high-voltage reference source	3	3.6	V
AD _{REFLO}	A-to-D low-voltage reference source	0	0.3	V
V _{AI}	Analog input voltage	AD _{REFLO}	AD _{REFHI}	V
I _{AIC}	Analog input clamp current ⁽²⁾ ($V_{AI} < V_{SSAD} - 0.3$ or $V_{AI} > V_{CCAD} + 0.3$)	-2	2	mA

(1) For V_{CCAD} and V_{SSAD} recommended operating conditions, see the "device recommended operating conditions" table.

(2) Input currents into any ADC input channel outside the specified limits could affect conversion results of other channels.

7.16.3 Operating Characteristics Over Full Ranges Of Recommended Operating Conditions

Table 7-27. Operating Characteristics Over Full Ranges Of Recommended Operating Conditions⁽¹⁾

Parameter		Description/Conditions	Min	TYP	Max	Unit
R _{mux}	Analog input mux on-resistance				250	Ω
R _{samp}	ADC sample switch on-resistance			150	250	Ω
C _{mux}	Input mux capacitance				16	pF
C _{samp}	ADC sample capacitance		11	12	13	pF
I _{AIL}	Analog input leakage current	Input leakage per ADC input pin	-200		200	nA
I _{ADREFHI}	AD _{REFHI} input current	AD _{REFHI} = 3.6 V, AD _{REFLO} = V _{SSAD}			5	mA
CR	Conversion range over which specified accuracy is maintained	AD _{REFHI} - AD _{REFLO}	3		3.6	V
E _{DNL}	Differential nonlinearity error	Difference between the actual step width and the ideal value.			±2	LSB
E _{INL}	Integral nonlinearity error	Maximum deviation from the best straight line through the MibADC. MibADC transfer characteristics, excluding the quantization error.			± 2	LSB
E _{TOT}	Total error/Absolute accuracy	Maximum value of the difference between an analog value and the ideal midstep value.			± 4	LSB

(1) 1 LSB = (AD_{REFHI} - AD_{REFLO}) / 2¹² for the MibADC

PRODUCT PREVIEW

7.16.4 MibADC Input Model

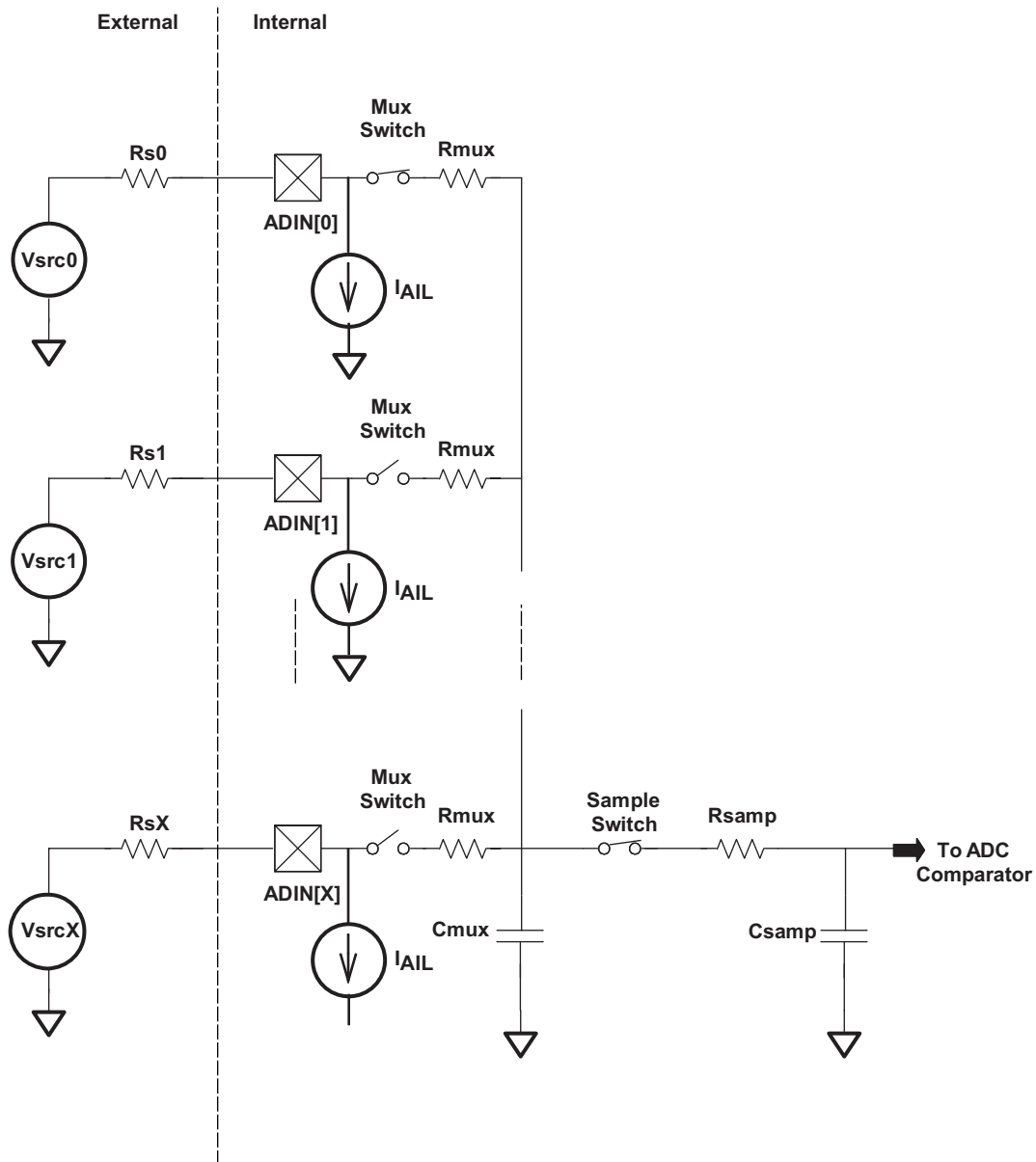

Figure 7-27. MibADC Input Equivalent Circuit

PRODUCT PREVIEW

7.16.5 MibADC Timings

Table 7-28. MibADC Timings

		Min	NOM	MAX	Unit
$t_{c(ADCLK)}$	Cycle time, MibADC clock	33			ns
$t_{d(SH)}$	Delay time, sample and hold time	200			ns
$t_{d@}$	Delay time, conversion time	400			ns
$t_{d(SHC)}^{(1)}$	Delay time, total sample/hold and conversion time	600			ns

(1) This is the minimum sample/hold and conversion time that can be achieved. These parameters are dependent on many factors, e.g the prescale settings.

7.16.6 MibADC Nonlinearity Error

The differential nonlinearity error shown in the figure below (sometimes referred to as differential linearity) is the difference between an actual step width and the ideal value of 1 LSB.

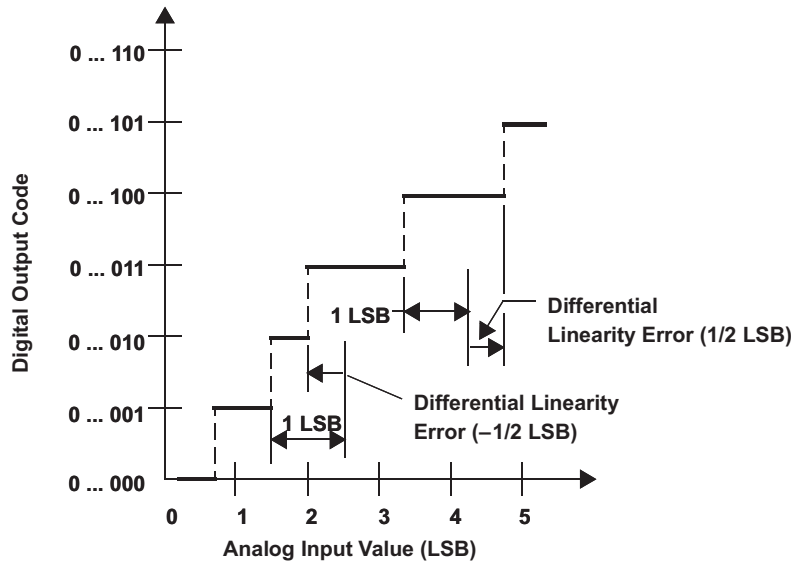

Figure 7-28. Differential Nonlinearity (DNL) Error

The integral nonlinearity error shown in the figure below (sometimes referred to as linearity error) is the deviation of the values on the actual transfer function from a straight line.

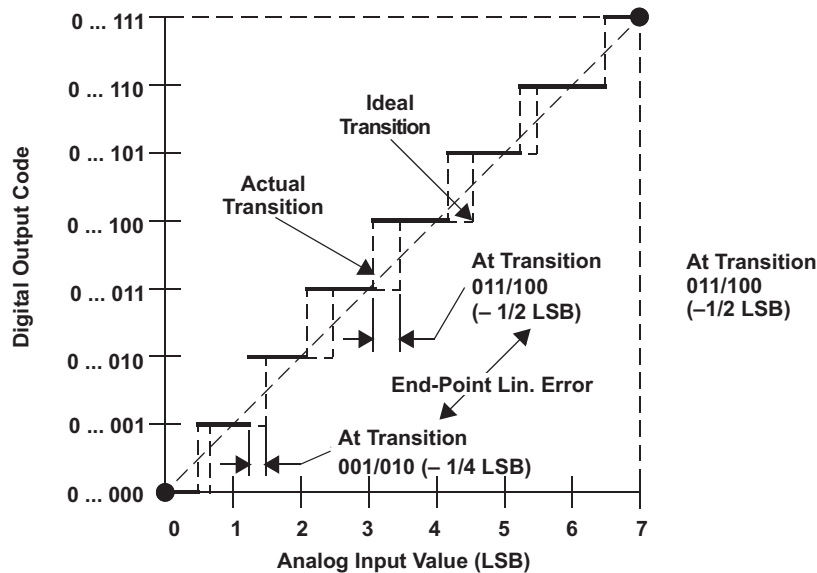

Figure 7-29. Integral Nonlinearity (INL) Error

7.16.7 MibADC Total Error

The absolute accuracy or total error of an MibADC as shown in the figure below is the maximum value of the difference between an analog value and the ideal midstep value.

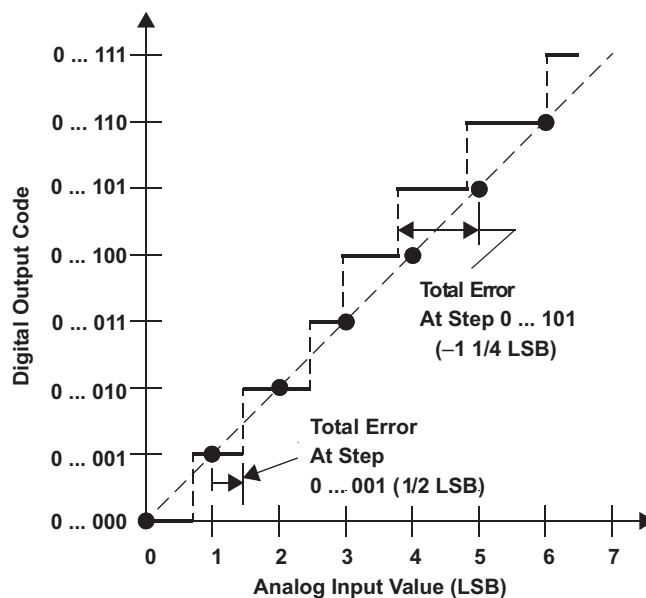

Figure 7-30. Absolute Accuracy (Total) Error

PRODUCT PREVIEW

8 Mechanical Packaging and Orderable Information

The following table(s) show the thermal resistance for the PBGA-ZWT and PQFP-PGE mechanical packages.

8.1 Thermal Data

8.1.1 PGE (S-PQFP-G144) plastic Quad Flat Pack

Table 8-1. PGE (S-PQFP-G144) Thermal Resistance Characteristics

PARAMETER	°C / W
RQJA	45
RQJC	5

8.1.2 ZWT (S-PBGA-N337) Plastic ball grid array

Table 8-2. ZWT (S-PBGA-N337) Thermal Resistance Characteristics

PARAMETER	°C / W
RQJA	TBD
RQJC	TBD

8.2 Packaging Information

The following packaging information and addendum reflect the most current data available for the designated device(s). The data is subject to change without notice and without revision of this document.

PACKAGING INFORMATION

Orderable Device	Status ⁽¹⁾	Package Type	Package Drawing	Pins	Package Qty	Eco Plan ⁽²⁾	Lead/Ball Finish	MSL Peak Temp ⁽³⁾
X5LS20216ASPGEQQ1	ACTIVE	LQFP	PGE	144	1	TBD	Call TI	Call TI
X5LS20216ASZWTQQ1	ACTIVE	NFBGA	ZWT	337	1	TBD	Call TI	Call TI

⁽¹⁾ The marketing status values are defined as follows:

ACTIVE: Product device recommended for new designs.

LIFEBUY: TI has announced that the device will be discontinued, and a lifetime-buy period is in effect.

NRND: Not recommended for new designs. Device is in production to support existing customers, but TI does not recommend using this part in a new design.

PREVIEW: Device has been announced but is not in production. Samples may or may not be available.

OBsolete: TI has discontinued the production of the device.

⁽²⁾ Eco Plan - The planned eco-friendly classification: Pb-Free (RoHS), Pb-Free (RoHS Exempt), or Green (RoHS & no Sb/Br) - please check <http://www.ti.com/productcontent> for the latest availability information and additional product content details.

TBD: The Pb-Free/Green conversion plan has not been defined.

Pb-Free (RoHS): TI's terms "Lead-Free" or "Pb-Free" mean semiconductor products that are compatible with the current RoHS requirements for all 6 substances, including the requirement that lead not exceed 0.1% by weight in homogeneous materials. Where designed to be soldered at high temperatures, TI Pb-Free products are suitable for use in specified lead-free processes.

Pb-Free (RoHS Exempt): This component has a RoHS exemption for either 1) lead-based flip-chip solder bumps used between the die and package, or 2) lead-based die adhesive used between the die and leadframe. The component is otherwise considered Pb-Free (RoHS compatible) as defined above.

Green (RoHS & no Sb/Br): TI defines "Green" to mean Pb-Free (RoHS compatible), and free of Bromine (Br) and Antimony (Sb) based flame retardants (Br or Sb do not exceed 0.1% by weight in homogeneous material)

⁽³⁾ MSL, Peak Temp. -- The Moisture Sensitivity Level rating according to the JEDEC industry standard classifications, and peak solder temperature.

Important Information and Disclaimer: The information provided on this page represents TI's knowledge and belief as of the date that it is provided. TI bases its knowledge and belief on information provided by third parties, and makes no representation or warranty as to the accuracy of such information. Efforts are underway to better integrate information from third parties. TI has taken and continues to take reasonable steps to provide representative and accurate information but may not have conducted destructive testing or chemical analysis on incoming materials and chemicals. TI and TI suppliers consider certain information to be proprietary, and thus CAS numbers and other limited information may not be available for release.

In no event shall TI's liability arising out of such information exceed the total purchase price of the TI part(s) at issue in this document sold by TI to Customer on an annual basis.

ZWT (S-PBGA-N337)

PLASTIC BALL GRID ARRAY

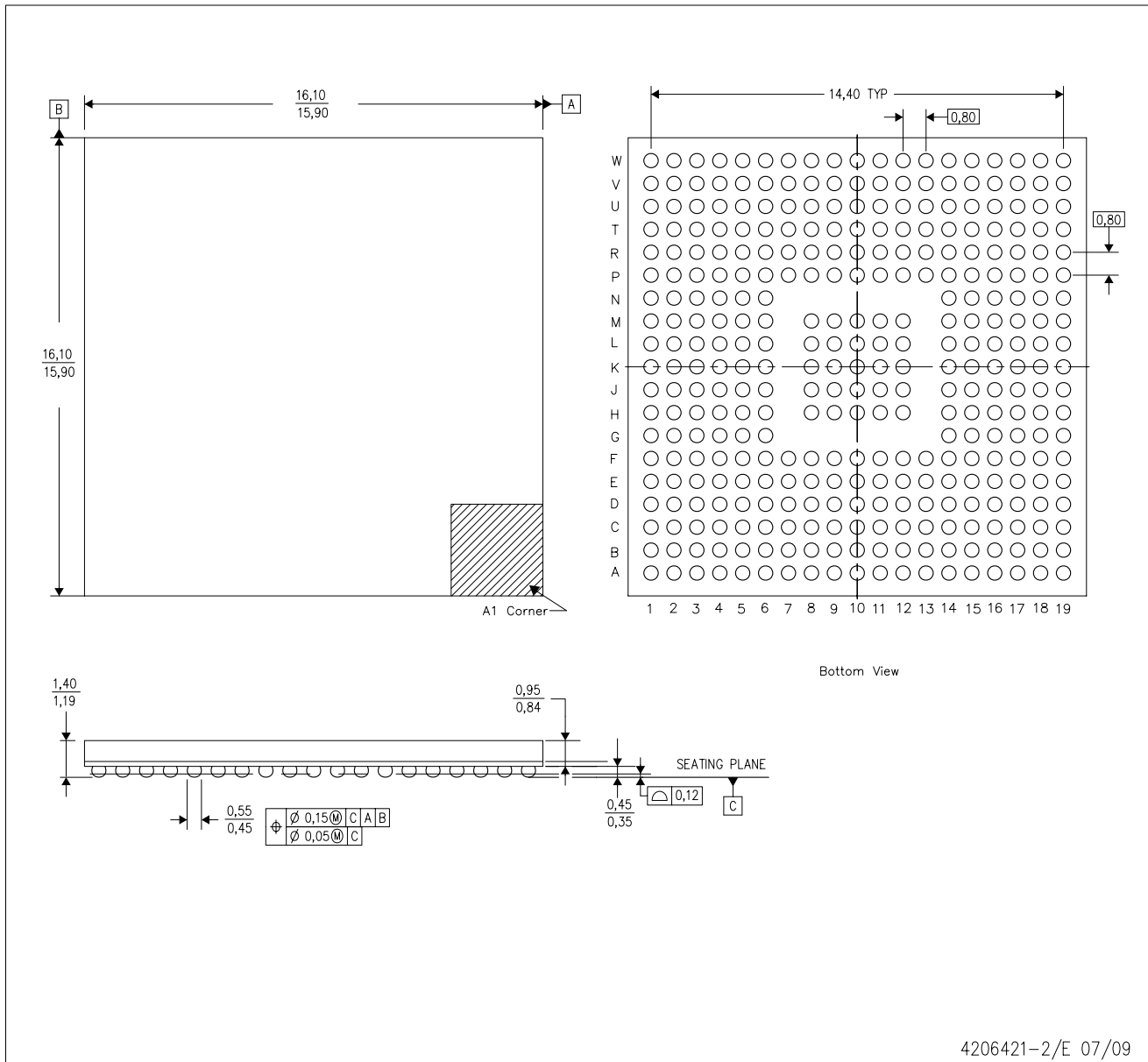

- NOTES:
- A. All linear dimensions are in millimeters. Dimensioning and tolerancing per ASME Y14.5M-1994.
 - B. This drawing is subject to change without notice.
 - C. This is a Pb-free solder ball design.
 - D. Falls within JEDEC MO-275.

PGE (S-PQFP-G144)

PLASTIC QUAD FLATPACK

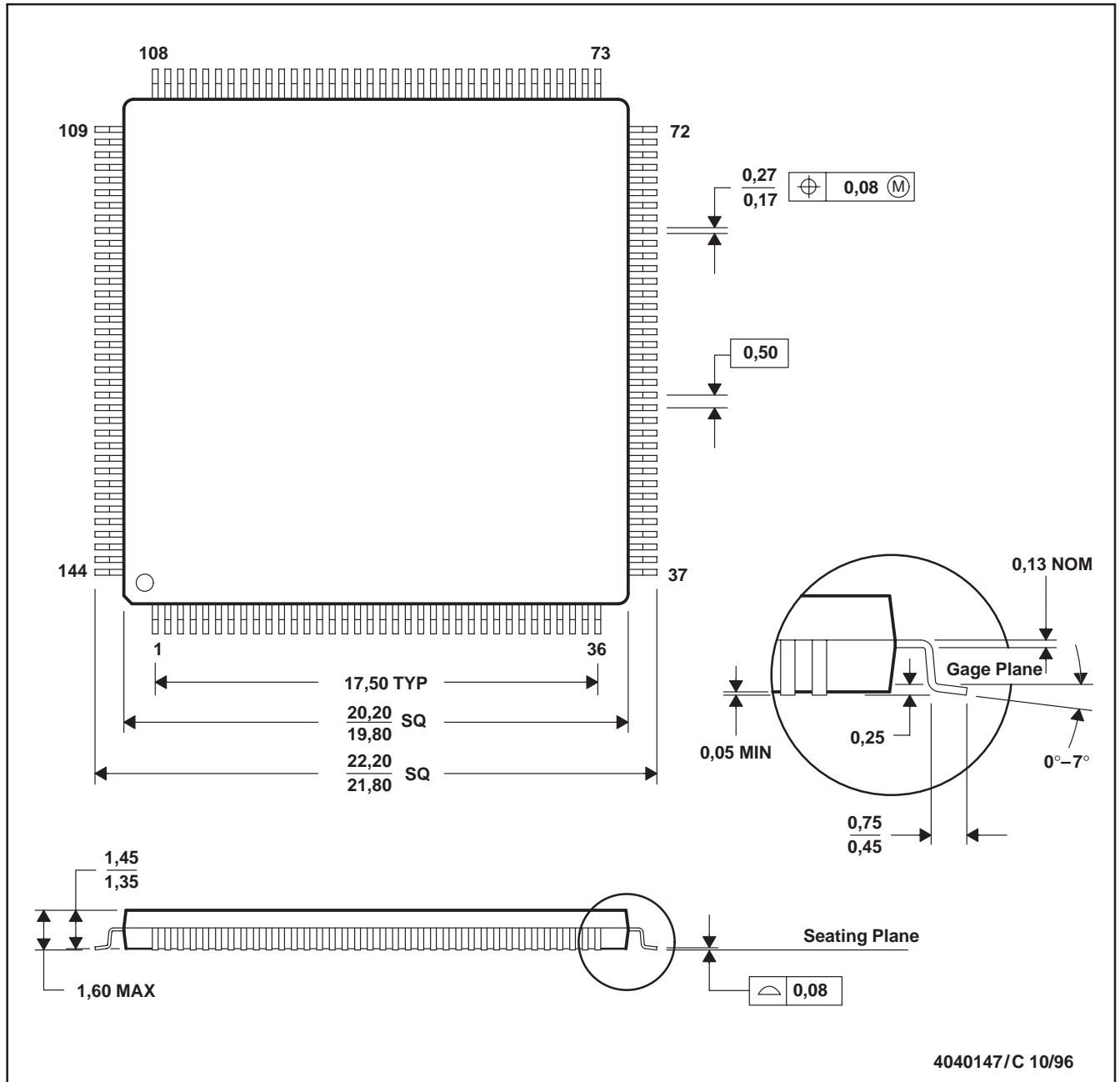

- NOTES: A. All linear dimensions are in millimeters.
 B. This drawing is subject to change without notice.
 C. Falls within JEDEC MS-026

IMPORTANT NOTICE

Texas Instruments Incorporated and its subsidiaries (TI) reserve the right to make corrections, modifications, enhancements, improvements, and other changes to its products and services at any time and to discontinue any product or service without notice. Customers should obtain the latest relevant information before placing orders and should verify that such information is current and complete. All products are sold subject to TI's terms and conditions of sale supplied at the time of order acknowledgment.

TI warrants performance of its hardware products to the specifications applicable at the time of sale in accordance with TI's standard warranty. Testing and other quality control techniques are used to the extent TI deems necessary to support this warranty. Except where mandated by government requirements, testing of all parameters of each product is not necessarily performed.

TI assumes no liability for applications assistance or customer product design. Customers are responsible for their products and applications using TI components. To minimize the risks associated with customer products and applications, customers should provide adequate design and operating safeguards.

TI does not warrant or represent that any license, either express or implied, is granted under any TI patent right, copyright, mask work right, or other TI intellectual property right relating to any combination, machine, or process in which TI products or services are used. Information published by TI regarding third-party products or services does not constitute a license from TI to use such products or services or a warranty or endorsement thereof. Use of such information may require a license from a third party under the patents or other intellectual property of the third party, or a license from TI under the patents or other intellectual property of TI.

Reproduction of TI information in TI data books or data sheets is permissible only if reproduction is without alteration and is accompanied by all associated warranties, conditions, limitations, and notices. Reproduction of this information with alteration is an unfair and deceptive business practice. TI is not responsible or liable for such altered documentation. Information of third parties may be subject to additional restrictions.

Resale of TI products or services with statements different from or beyond the parameters stated by TI for that product or service voids all express and any implied warranties for the associated TI product or service and is an unfair and deceptive business practice. TI is not responsible or liable for any such statements.

TI products are not authorized for use in safety-critical applications (such as life support) where a failure of the TI product would reasonably be expected to cause severe personal injury or death, unless officers of the parties have executed an agreement specifically governing such use. Buyers represent that they have all necessary expertise in the safety and regulatory ramifications of their applications, and acknowledge and agree that they are solely responsible for all legal, regulatory and safety-related requirements concerning their products and any use of TI products in such safety-critical applications, notwithstanding any applications-related information or support that may be provided by TI. Further, Buyers must fully indemnify TI and its representatives against any damages arising out of the use of TI products in such safety-critical applications.

TI products are neither designed nor intended for use in military/aerospace applications or environments unless the TI products are specifically designated by TI as military-grade or "enhanced plastic." Only products designated by TI as military-grade meet military specifications. Buyers acknowledge and agree that any such use of TI products which TI has not designated as military-grade is solely at the Buyer's risk, and that they are solely responsible for compliance with all legal and regulatory requirements in connection with such use.

TI products are neither designed nor intended for use in automotive applications or environments unless the specific TI products are designated by TI as compliant with ISO/TS 16949 requirements. Buyers acknowledge and agree that, if they use any non-designated products in automotive applications, TI will not be responsible for any failure to meet such requirements.

Following are URLs where you can obtain information on other Texas Instruments products and application solutions:

Products		Applications	
Amplifiers	amplifier.ti.com	Audio	www.ti.com/audio
Data Converters	dataconverter.ti.com	Automotive	www.ti.com/automotive
DLP® Products	www.dlp.com	Communications and Telecom	www.ti.com/communications
DSP	dsp.ti.com	Computers and Peripherals	www.ti.com/computers
Clocks and Timers	www.ti.com/clocks	Consumer Electronics	www.ti.com/consumer-apps
Interface	interface.ti.com	Energy	www.ti.com/energy
Logic	logic.ti.com	Industrial	www.ti.com/industrial
Power Mgmt	power.ti.com	Medical	www.ti.com/medical
Microcontrollers	microcontroller.ti.com	Security	www.ti.com/security
RFID	www.ti-rfid.com	Space, Avionics & Defense	www.ti.com/space-avionics-defense
RF/IF and ZigBee® Solutions	www.ti.com/lprf	Video and Imaging	www.ti.com/video
		Wireless	www.ti.com/wireless-apps

Mailing Address: Texas Instruments, Post Office Box 655303, Dallas, Texas 75265
Copyright © 2010, Texas Instruments Incorporated