

---

### Features

---

- I EIA size:1210
- I Variable capacitance
- I Operating voltage: 14Vdc ~385Vdc
- I High surge suppress capability
- I Bidirectional and symmetrical V/I characteristics
- I Multilayer ceramic construction technology
- I RoHS & Halogen Free (HF) compliant
- I Operating temperature range: -40°C ~ +85°C
- I Storage temperature range: -40°C ~ +125°C



---

### Applications

---

- I Used to Help Achieve Electromagnetic Compliance of End Products
- I Provides On-Board Transient Voltage Protection for ICs, CMOS and MOSFET
- I Suppression of Inductive Switching or Other Transient Events Such as EFT and Surge Voltage at the Circuit Board.
- I Protection of Components and Circuits Sensitive to ESD Transients Occurring on Power supplies, Control and Signal Lines.

---

### Part Number Code

---

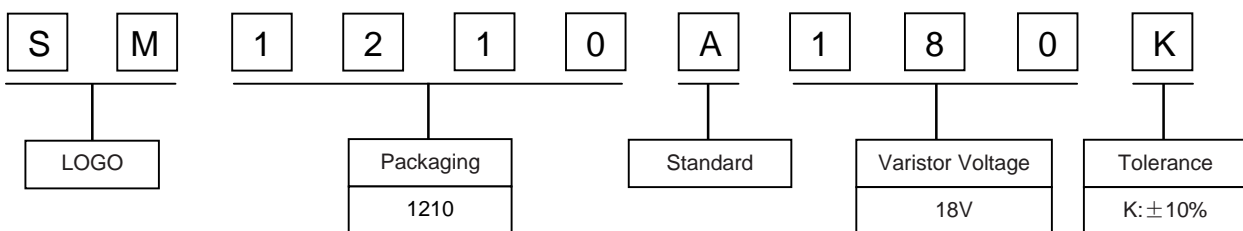



## Electrical Characteristics

Type Number	Varistor Voltage	Max. Allowable Voltage		Max. Energy (10/1000 $\mu$ s)	Max. Clamping Voltage (8/20 $\mu$ s)		Withstanding Surge Current (8/20 $\mu$ s)
	V <sub>1mA</sub> (V)	V <sub>AC</sub> (V)	V <sub>DC</sub> (V)	(J)	I <sub>P</sub> (A)	V <sub>C</sub> (V)	I(A)
SM1210A180K	16.8~21	11	14	0.8	5	46	250
SM1210A210K	19.2~24	13	16	0.8	5	52	250
SM1210A240K	21.6~27	14	18	0.8	5	59	250
SM1210A270K	26.4~33	17	22	0.8	5	72	250
SM1210A300K	28.8~36	18	24	0.8	5	79	250
SM1210A330K	31.2~39	20	26	0.8	5	85	250
SM1210A360K	33.6~42	21	28	0.8	5	92	250
SM1210A390K	36~45	25	30	0.8	5	99	250
SM1210A420K	39.6~49.5	28	33	0.8	5	108	250
SM1210A470K	45.6~57	30	38	0.8	5	125	250
SM1210A530K	50.4~63	32	42	0.8	5	138	250
SM1210A560K	54~67.5	35	45	0.8	5	148	250
SM1210A600K	57.6~72	36	48	0.8	5	158	250
SM1210A680K	67.2~84	40	56	0.8	5	184	250
SM1210A760K	72~90	43	60	0.8	5	198	250
SM1210A820K	78~97.5	47	65	0.8	5	214	250
SM1210A950K	90~112.5	50	75	0.8	5	247	250
SM1210A241K	216~264	150	200	0.8	5	415	250
SM1210A271K	243~297	175	225	0.8	5	475	250
SM1210A391K	351~429	250	320	0.8	5	675	/
SM1210A431K	387~473	275	350	0.8	5	710	/
SM1210A471K	423~517	300	385	0.8	5	775	/

## Environmental Performance

Item	Specifications	Test Condition
Bias Humidity	V <sub>V</sub> / V <sub>V</sub> ≤±10%	90%RH, 40°C, Working Voltage, 1000 hrs
Thermal Shock	V <sub>V</sub> / V <sub>V</sub> ≤±10%	-40°C to 85°C, 30min.cycle, 5 cycles
Full Load Voltage	V <sub>V</sub> / V <sub>V</sub> ≤±10%	Working Voltage, 85°C, 1000 hrs

## General Technical Data

Operating Temperature	-40~+85 °C	
Storage Temperature	-40~+125 °C	
Response Time	<1ns	
Solderability	245±5 °C, 3±1sec	
Solder leach resistance	260±5 °C, 10±1sec	
Taping Package Storage Condition	Storage Temperature	5~40°C
	Relative Humidity	To 65%
	Storage Time	12 Months max

## Soldering Parameters - Reflow Soldering (Surface Mount Devices)

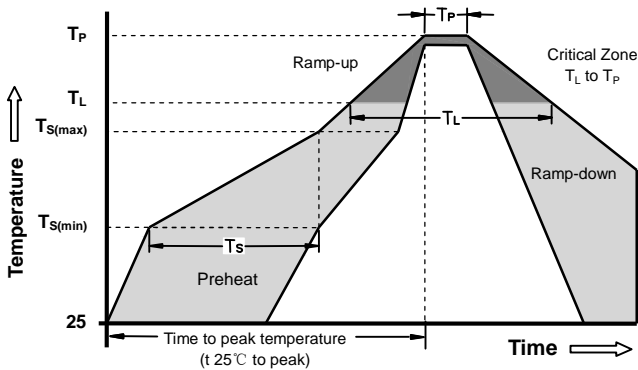

Reflow Condition		Pb - Free assembly
Pre Heat	-Temperature Min ( $T_{s(min)}$ )	150°C
	-Temperature Max ( $T_{s(max)}$ )	200°C
	- Time (min to max) ( $t_s$ )	60 -180 Seconds
Average ramp up rate ( Liquids Temp $T_L$ ) to peak		3°C/second max
$T_{s(max)}$ to $T_L$ - Ramp-up Rate		3°C/second max
Reflow	- Temperature ( $T_L$ ) (Liquids)	217°C
	- Time (min to max) ( $t_s$ )	60 -150 Seconds
Peak Temperature ( $T_P$ )		260 +0/-5°C
Time within 5°C of actual peak Temperature ( $t_p$ )		20 - 40 Seconds
Ramp-down Rate		6°C/second max
Time 25°C to peak Temperature ( $T_P$ )		8 minutes Max
Do not exceed		260°C

### Precaution for soldering

Note that this product will be easily damaged by rapid heating, rapid cooling or local heating.

Do not give heat shock over 100°C in the process of soldering. We recommend to take preheating and gradual cooling

### Soldering gun procedure

Note the follows, in case of using solder gun for replacement.

- 1)The tip temperature must be less than 280 for the period within 3 seconds by using soldering gun under 30W
- 2) The soldering gun tip shall not touch this product directly.

### Soldering volume

Note that excess of soldering volume will easily get crack the body of this product.

## Dimensions

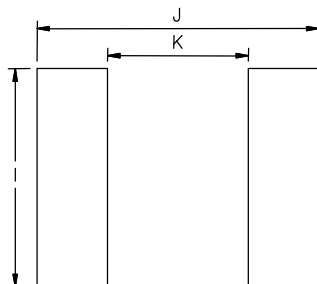
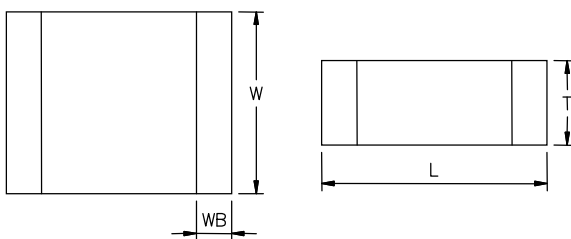

Recommended Soldering Pad Layout

Symbol	Millimeters	Inches
L	3.20±0.30	0.126±0.012
W	2.50±0.30	0.098±0.012
$T_{max}$	2.50	0.098
WB	0.50±0.20	0.02±0.008
I	3.0	0.118
J	4.0	0.157
K	2.0	0.079

## Taping and Reel Specifications

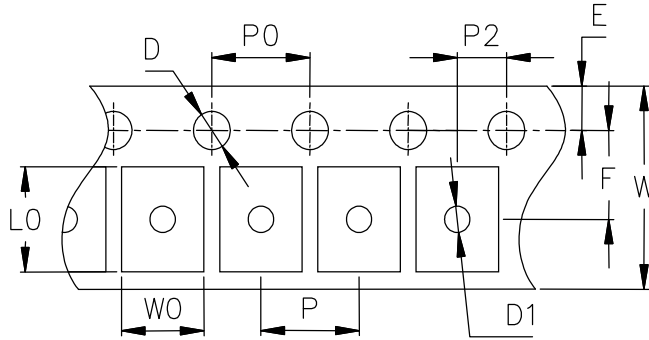

Symbol	Millimeters	Inches
<b>W</b>	8.00±0.20	0.315±0.008
<b>E</b>	1.75±0.10	0.069±0.004
<b>F</b>	3.50±0.05	0.138±0.002
<b>D</b>	1.55±0.05	0.061±0.002
<b>D1</b>	Φ1.00±0.05	Φ0.039±0.002
<b>P</b>	4.00±0.10	0.157±0.004
<b>P0</b>	4.00±0.05	0.157±0.002
<b>P2</b>	2.00±0.05	0.079±0.002
<b>L0</b>	4.00±0.10	0.157±0.004
<b>W0</b>	3.25±0.10	0.128±0.004

## Packing Specifications

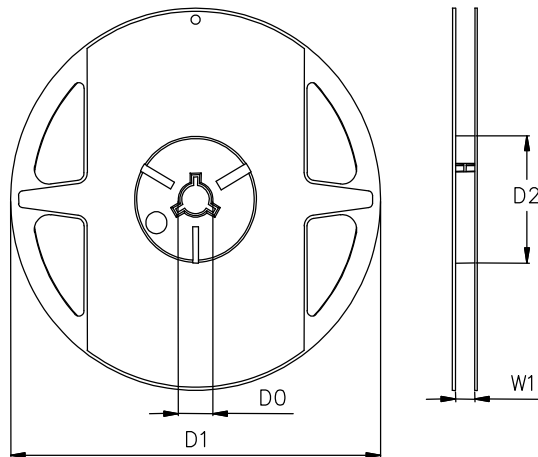

Symbol	Millimeters	Inches
<b>D0</b>	13.0±0.2	0.512±0.008
<b>D1</b>	178±2.0	7.008±0.079
<b>D2</b>	Φ60.0±0.5	Φ2.362±0.02
<b>W1</b>	9.0±0.5	0.354±0.02

### Taping Specifications

There shall be the portion having no product in both the head and the end of taping, and there shall be the cover tape in the heat of taping.

### Quantity of products in the taping package

SIZE EIA (EIAJ)	SM1210A241/271/391/431/471K	SM1210A Series Other
Standard Packing Quantity (PCS/reel)	2000	3000