

PLEASE CHECK WWW.MOLEX.COM FOR LATEST PART INFORMATION

Part Number: [0190030027](#)
Status: **Active**
Description: InsulKrimp™ Quick Disconnect, Female, for 18-22 (0.80-0.35), Box, Tab 2.79mm (.110") x 0.51mm (.020")

Documents:

[Drawing \(PDF\)](#) [RoHS Certificate of Compliance \(PDF\)](#)
[Product Specification PS-19902-008 \(PDF\)](#)

Agency Certification

CSA LR18689
 UL E79133

General

Product Family Quick Disconnects
 Series [19003](#)
 Comments Funnel Entry
 Crimp Quality Equipment Yes
 Product Name InsulKrimp™
 Type Quick Disconnect

Physical

Barrel Type Closed
 Color - Resin Natural
 Flammability 94V-2
 Gender Female
 Glow-Wire Compliant No
 Insulation Nylon (PA)
 Lock to Mating Part None
 Material - Metal Brass
 Material - Plating Mating Tin
 Material - Plating Termination Tin
 Material - Resin Nylon
 Orientation Straight
 Packaging Type Bag
 Plating min: Mating (µin) 160
 Plating min: Mating (µm) 4
 Plating min: Termination (µin) 160
 Plating min: Termination (µm) 4
 Polarized to Mating Part No
 Tab Thickness 0.51mm (.020")
 Tab Width 2.79mm (.110")
 Temperature Range - Operating -65°C to +105°C
 Termination Interface: Style Crimp or Compression
 Wire Insulation Diameter 5.84mm (.230") max.
 Wire Size AWG 18, 20, 22
 Wire Size mm² 0.35 - 0.80

Electrical

Voltage - Maximum 600V

Material Info

Old Part Number AA-2204X

Reference - Drawing Numbers

Product Specification PS-19902-008
 Sales Drawing SD-19003-006

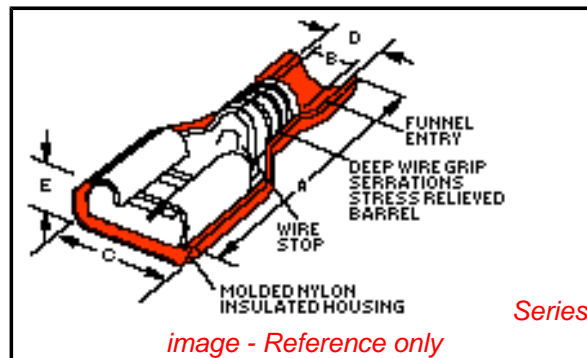

image - Reference only

EU RoHS

ELV and RoHS Compliant

REACH SVHC

Not Reviewed

Halogen-Free

Status

Not Reviewed

China RoHS



Need more information on product environmental compliance?

Email productcompliance@molex.com
 For a multiple part number RoHS Certificate of Compliance, [click here](#)

Please visit the [Contact Us](#) section for any non-product compliance questions.

Search Parts in this Series

[19003Series](#)

Application Tooling | [FAQ](#)

Tooling specifications and manuals are found by selecting the products below. Crimp Height Specifications are then contained in the Application Tooling Specification document.

Global

Description	Product #
Hand Crimp Tool	0640010400
Hand Crimp Tool	0640010700
Crimp Head for the AT-200™ Pneumatic Hand Tool	0640050400

This document was generated on 04/13/2010

PLEASE CHECK WWW.MOLEX.COM FOR LATEST PART INFORMATION

10	9	8	7	6	5	4	3	2					
MATERIAL # LOOSE PCS	MATERIAL # CONTINUOUS	MATERIAL # TAPE MNT	MOLEX-ETC PART NO.	INS. COLOR	WIRE RANGE AWG	FITS MALE TAB SIZE	STOCK THICK REF	"A" MAX	"B" MIN.	"C" MAX.	"D" MWID	"E" MAX.	"H" NOMINAL
190030008	190030009	190030010	AA-2201X	RED	22-18	.250x.032 (6.35x0.81)	.016 (0.4)	.94 (23.9)	.058 (1.47)	.380 (9.66)	.230 (5.84)	.180 (4.58)	.56 (14.2)
NOTE 5	NOTE 5	NOTE 5	AA-2213X	RED	22-18	.205x.020 (5.21x0.51)	.016 (0.4)	.86 (21.8)	.058 (1.47)	.316 (8.03)	.230 (5.84)	.160 (4.07)	.60 (15.3)
NOTE 5	NOTE 5	NOTE 5	AA-2214X	PINK (B)	22-18	.205x.032 (5.21x0.81)	.016 (0.4)	.86 (21.8)	.058 (1.47)	.316 (8.03)	.230 (5.84)	.160 (4.07)	.60 (15.3)
190030014	190030015	190030016	AA-2202X	RED	22-18	.187x.020 (4.75x0.51)	.016 (0.4)	.86 (21.8)	.058 (1.47)	.316 (8.03)	.230 (5.84)	.160 (4.07)	.60 (15.3)
190030021	190030022	190030023	AA-2203X	PINK (B)	22-18	.187x.032 (4.75x0.81)	.016 (0.4)	.86 (21.8)	.058 (1.47)	.316 (8.03)	.230 (5.84)	.160 (4.07)	.60 (15.3)
190030027	190030028	190030029	AA-2204X	RED	22-18	.110x.020 (2.79x0.51)	.012 (0.3)	.86 (21.8)	.058 (1.47)	.230 (5.85)	.230 (5.84)	.150 (3.81)	.61 (15.5)
190030033	190030034	190030035	AA-2205X	PINK (B)	22-18	.110x.032 (2.79x0.81)	.012 (0.3)	.86 (21.8)	.058 (1.47)	.230 (5.85)	.230 (5.84)	.150 (3.81)	.61 (15.5)
190030047	190030048	100030049	BB-2206X	BLUE	16-14	.250x.032 (6.35x0.81)	.016 (0.4)	.94 (23.9)	.083 (2.10)	.380 (9.66)	.260 (6.60)	.180 (4.58)	.56 (14.2)
NOTE 5	NOTE 5	NOTE 5	BB-2215X	BLUE	16-14	.205x.020 (5.21x0.51)	.016 (0.4)	.86 (21.8)	.083 (2.10)	.316 (8.03)	.260 (6.60)	.170 (4.32)	.60 (15.3)
NOTE 5	NOTE 5	NOTE 5	BB-2216X	AQUA (B)	16-14	.205x.032 (5.21x0.81)	.016 (0.4)	.86 (21.8)	.083 (2.10)	.316 (8.03)	.260 (6.60)	.170 (4.32)	.60 (15.3)
190030053	190030054	190030055	BB-2207X	BLUE	16-14	.187x.020 (4.75x0.51)	.016 (0.4)	.86 (21.8)	.083 (2.10)	.316 (8.03)	.260 (6.60)	.170 (4.32)	.60 (15.3)
190030059	190030060	190030061	BB-2208X	AQUA (B)	16-14	.187x.032 (4.75x0.81)	.016 (0.4)	.86 (21.8)	.083 (2.10)	.316 (8.03)	.260 (6.60)	.170 (4.32)	.60 (15.3)
190050010	190050014	190050015	C-2265	YELLOW	12-10	.250x.032 (6.35x0.81)	.018 (0.5)	1.04 (26.4)	.150 (3.81)	.380 (9.66)	.275 (6.98)	.290 (7.37)	.51 (12.9)

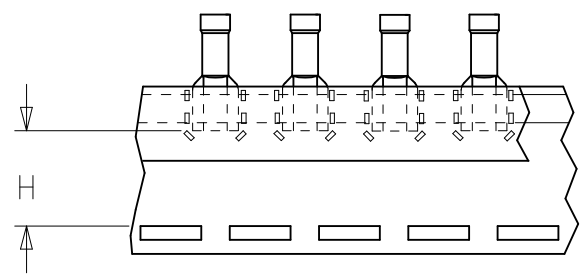
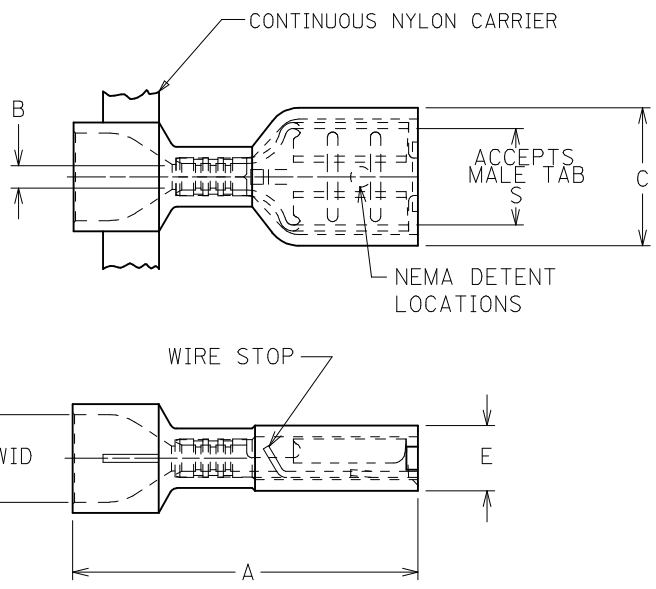

PARTS ON TAPE

CUSTOMER DRAWING

1. MATERIAL: BRASS
2. FINISH: ELECTRO-TIN PLATING
3. INSULATION: NYLON
4. MWID= MAXIMUM WIRE INSULATION DIAMETER
5. CONSULT FACTORY FOR AVAILABILITY
6. PART IS ROHS COMPLIANT.

REDRAW, COLOR CHGS EC NO: WNA2008-0135 DRW: HETHRODAHL 2008/09/23 CHKD: JMACNEIL 2008/09/23 APPR: JMACNEIL 2008/09/25	QUALITY SYMBOLS ▽=0 ▽=0	GENERAL TOLERANCES (UNLESS SPECIFIED)		DIMENSION STYLE IN/MM		SCALE ---	DESIGN UNITS INCH	THIRD ANGLE PROJECTION		
		4 PLACES ± --- ± ---	3 PLACES ± --- ± ---	2 PLACES ± --- ± ---	1 PLACE ± --- ± ---	ANGULAR ± ---°	DRAWN BY DATE RCM 1994/06/17	CHECKED BY DATE JM 1994/06/17	APPROVED BY DATE FP 1994/06/17	TITLE FULLY INSULATED QUICK DISCONNECTS EXPANDED FLARE
		DRAFT WHERE APPLICABLE MUST REMAIN WITHIN DIMENSIONS			MATERIAL NO. SEE CHART	DOCUMENT NO. SD-19003-006	SHEET NO. 1 OF 1	MOLEX INCORPORATED		
		THIS DRAWING CONTAINS INFORMATION THAT IS PROPRIETARY TO MOLEX INCORPORATED AND SHOULD NOT BE USED WITHOUT WRITTEN PERMISSION								