

ATLANTIC VERSION TERMINATOR INTERFACE ADAPTER	PART NUMBER	REVISION	DESCRIPTION	FEED TYPE	APPLICATOR STYLE CONVERSION CHART					
					CONVERT TO	PART NUMBERS REQUIRED				
	2266257-2	C	FINE CRIMP HEIGHT ADJUST	PNEUMATIC	-	-	-	-	-	-
	2266257-5	C	FINE CRIMP HEIGHT ADJUST	SERVO LATCH PLATE	2119951-1	-	8-2266257-5	1901094-3	-	2168400-6 (QUANTITY 2)
	2266257-6	C	NON-CRIMP HEIGHT ADJUST	SERVO LATCH PLATE	2161326-1	-	8-2266257-4	-	-	-
	2266257-7	C	FINE CRIMP HEIGHT ADJUST	NONE	-	-	-	-	-	-
	7-2266257-7	A	CRIMP TOOLING KIT	-	-	-	-	-	-	-

APPLICATOR DATA		
CRIMP	SIZE	TYPE
WIRE	5.33 mm [.210]	F
INSUL	9.91 mm [.390]	O

APPLICATOR INSTRUCTIONS
408-10389

TERMINAL DATA: TE TERMINAL		TE CRIMP SPECIFICATION	
TERMINAL NAME: MECON 8 CONTACT			
WIRE STRIP LENGTH		INSULATION DIAMETER RANGE	
4.34-5.11 mm [.171-.201 IN]			
TERMINAL APPLICATION SPECIFICATION	114-94285		
TERMINALS APPLIED			
TE TERMINAL	TE TERMINAL	TE SEAL	TE SEAL
2208766-1			1K0972744B
			1949052-1
			4.00-5.80mm
			4.00-5.80mm

WIRE SIZE	CRIMP HEIGHT mm [INCH]	CRIMP HEIGHT REFERENCE SETTING
10.00mm2	3.35+/-0.1 [.132+/- .004]	6.0
6.00mm2	2.80+/-0.1 [.110+/- .004]	11.5

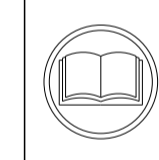

- RECOMMENDED SPARE PARTS
- GREASE BEARING SURFACES LIGHTLY
- LUBRICATE DAILY PER THE APPLICATOR INSTRUCTION SHEET SUPPLIED WITH THE APPLICATOR.
- APPLICATOR SPECIFIC DATA TO BE ENTERED INTO BLANK MEMORY CHIP AT ASSEMBLY. SEE BELOW FOR PART NUMBER:
 PNEUMATIC FEED WITH "SMART APPLICATOR" CONVERSION: 8-2266257-4
 SERVO FEED WITH "FINE CRIMP HEIGHT ADJUST": 8-2266257-5
 SERVO FEED WITH "NON-CRIMP HEIGHT ADJUST": 8-2266257-6
- ADJUSTMENT OF THE STRIPPER MAY BE REQUIRED WHEN MOVING THE APPLICATOR BETWEEN BENCH AND LEADMAKER APPLICATIONS.
- APPLY PART NUMBER 1-23419-5 LOCTITE TO THREADS OF ITEMS 62.
 APPLY PART NUMBER 2-23419-6 LOCTITE TO THREADS OF ITEMS 242.
 FOR -6 ONLY APPLY PART NUMBER 1-23419-5 LOCTITE TO THREADS OF ITEMS 37.
- GREASE THREADS, GROOVE AND O-RING ON ITEMS 35 & 252.
- MAGNET, ITEM 166 MUST BE ORIENTED CORRECTLY IN ORDER TO PROPERLY ACTUATE THE COUNTER.
- CRIMP HEIGHT REFERENCE SETTING WAS THE SETTING USED WHEN THE APPLICATOR WAS QUALIFIED AT THE FACTORY. ADJUSTMENT MAY BE NECESSARY WHEN RUNNING APPLICATOR IN THE FIELD.
- TERMINAL PITCH NOT COMPATIBLE WITH MECHANICAL FEED.
- TO CONVERT THE APPLICATOR TO A NON-CARRIER CUTTING STYLE, REMOVE ITEM 13 AND ATTACH TO THE LOCATION ON THE BACK SIDE OF THE HOUSING. REFER TO INSTRUCTION SHEET FOR ADDITIONAL INFORMATION.
- WHEN ASSEMBLING A NON CRIMP HEIGHT ADJUST APPLICATOR (-6) USE SHIMS FROM ITEM 260 TO ACHIEVE A NOMINAL SHIM HEIGHT OF 2.96.
- THIS APPLICATOR APPLIES TERMINAL WITH A SEAL.
- CUT TO LENGTH AT ASSEMBLY.
- APPLY TORO-SEAL IN ALLEN SOCKET TO FILL HOLE AFTER SOCKET HEAD HAS BEEN ADJUSTED TO CORRECT HEIGHT AT QUALIFICATION.

***WARNING**
 ON INSTALLATION, SET WIRE DISC, ITEM 40 TO LARGEST WIRE SIZE SETTING. USE OF SETTINGS BELOW MINIMUM REQUIRED CRIMP HEIGHT SETTING WILL CAUSE DAMAGE TO CRIMP TOOLING.

16. FOR BEST RESULTS, WIRE MUST BE PLACED INTO WIRE BARREL PRIOR TO CRIMPING.

-	1	1	1	1	5018030-1	NUT, HEX, REG, RoHS, M3	270
-	-	1	-	-	2119957-2	APPLICATOR SHIM PACK	260
-	1	1	1	1	1803078-1	SPACER, PRECISION	259
-	1	-	1	1	8-21084-0	O-RING, .676 ID, .070 DIA. MAT.	252
-	-	-	-	1	2119640-1	PUSH ROD, AIR FEED	250
-	-	-	-	1	2079988-1	BUSHING, LCH5-12, MISUMI	249
-	-	-	-	1	2119641-1	FEED CAM, AIR FEED	248
-	1	-	1	1	2119798-1	DETENT PIN	247
-77	-7	-6	-5	-2	PART NO	DESCRIPTION	ITEM NO

ATLANTIC VERSION
 Shown on sheets 1 of 4 & 2 of 4
 (Pacific version shown on sheets 3 of 4 & 4 of 4)

SET UP GAUGE	LOC	DIST	REVISIONS					
2119599-1	A	66	P	LTN	DESCRIPTION	DATE	OWN	APVD
			C		ECR-15-015480	210CT2015	MR	GB

-	1	-	1	1	1-22279-3	SPRING, COMPRESSION	246
-	-	1	-	-	2161314-1	RAM, STEPPED, ATLANTIC, SF, NON-ADJ	245
-	1	1	1	1	2119082-6	CAM, SNAIL, INSULATION ADJUSTMENT	244
-	1	1	1	1	2079764-1	WASHER, WAVE SPRING, CREST-TO-CREST	243
-	1	1	1	1	2119083-1	RETAINER, INSULATION DIAL	242
-	1	1	1	1	7-18023-7	SCR, SKT HD CAP M3 X 4.0	241
-	-	2	2	-	2168400-6	SHCS, LOW HEAD, RoHS, M5 X 16	240
-	-	-	-	1	2063440-2	AIR FEED MODULE	238
-	-	1	1	-	2119740-2	TAG, IDENTIFICATION	213
-	-	1	1	-	1901094-3	SPACER, FEEDER	198
-	-	-	-	2	21045-3	RING, RETAIN, EXTERN, 3/16 CRESCENT	172
-	1	1	1	1	994969-1	MAGNET, RARE EARTH HIGH ENERGY	166
-	REF	REF	REF	REF	994970-2	COUNTER, MAGNETIC	164
-	-	-	-	1	240638-1	SPRING, FEED FINGER	163
-	-	-	-	1	3-23627-7	PIN, RETAIN, GRVD, 3/16 X .854	137
-	-	-	-	1	2119799-1	HOLDER, FEED FINGER, AF	136
-	-	REF	REF	-	SEE NOTE 4	MEMORY CHIP, PROGRAMMED	135
-	-	1	1	-	1633743-1	SERVO FEED LATCH ASM	133
-	-	REF	REF	-	2119944-1	FEED FINGER ASSEMBLY, SF	117
-	1	1	1	1	1-690438-0	FRONT STRIP GUIDE	96
-	1	1	1	1	1803078-1	SPACER, PRECISION	82
-	2	2	2	2	2079383-4	SCR, BHSC, RoHS (M4 X 8)	79
-	1	1	1	1	1803096-1	EXTENSION PLATE	78
-	1	1	1	1	2119956-1	DOCUMENTATION PACKAGE	71
-	1	1	1	1	2119791-7	DEPRESSOR, WIRE	70
-	1	1	1	1	2119943-1	WASHER, SPACER	69
-	1	-	-	1	2119740-1	TAG, IDENTIFICATION	67
-	2	2	2	2	2168078-1	SCREW, DRIVE, RH, RoHS, 2 x .188	66
-	1	-	1	1	2119793-1	LIMITER, ADJUSTMENT BOLT	63
-	3	-	3	3	992763-5	SCR, SET, SOC, CONE POINT, M3 X 4.0	62
-	1	1	1	1	2079383-4	SCR, BHSC, RoHS (M4 X 8)	60
-	-	-	-	1	5-18022-5	SCR, HEX HD CAP, M4 X 6.0	59
-	1	1	1	1	1-2168083-3	SCR, SKT HD CAP, RoHS, M3 X 16	57
-	-	-	-	1	1338683-8	FEED PAWL	56
-	4	4	4	4	2168400-1	SHCS, LOW HEAD, RoHS, M4 X 12	54
-	2	2	2	2	1-2168083-0	SCR, SKT HD CAP, RoHS, M4 X 10	53
-	1	1	1	1	5018030-1	NUT, HEX, REG, RoHS, M3	52
-	1	1	1	1	1-811242-0	BUMPER, HOLD DOWN	51
-	1	1	1	1	690753-2	SPACER, TONKER	50
-	-	-	-	1	18023-9	SCR, SKT HD CAP M4 X 6.0	49
-	1	1	1	1	1-2119656-7	APPLICATOR BASIC ASSEMBLY, SF	46
-	1	-	1	1	2161311-1	RAM, STEPPED, AMP STYLE, SIDE FEED	44
-	1	1	1	1	2079383-7	SCR, BHSC, RoHS (M8 X 25)	41
-	1	-	1	1	2119645-1	DISC, NUMBERED FA WIRE ADJUSTMENT	40
-	1	-	1	1	2119957-1	APPLICATOR SHIM PACK	39
-	1	1	1	1	2119644-3	RAM WASHER, PRECISION	38
-	1	1	1	1	2119085-1	FA HEAD, ATLANTIC STYLE	37
-	1	-	1	1	2119092-1	BOLT, ADJUSTMENT	35
-	1	1	1	1	5-1752356-0	SUPPORT, TERMINAL	34
-	2	2	2	2	2079383-5	SCR, BHSC, RoHS (M4 X 20)	33
-	1	1	1	1	2161328-1	HEX HEAD, FLANGED, M5 X 8mm LONG	32
-	1	1	1	1	1320908-7	SPACER, STRIP GUIDE	30
-	1	1	1	1	2119959-5	ASSEMBLY, STRIP GUIDE	29
-	1	1	1	1	455888-3	SPACER, CRIMPER	28
-	2	2	2	2	22283-1	SPRING, COMPRESSION	27
-	1	1	1	1	240792-1	DRAG, TERMINAL	25
-	1	1	1	1	1320928-4	STRIP GUIDE	24
-	1	1	1	1	2168083-2	SCR, SKT HD CAP, RoHS, M4 X 8.0	21
-	3	3	3	3	1-18028-2	WASHER, FLAT, REG M4	20
-	1	1	1	1	1803013-1	STRIPPER, SIDE FEED	19
-	1	1	1	1	2119806-1	INSERT, SHEAR	13
-	1	1	1	1	4-22280-7	SPRING, COMPRESSION	12
-	1	1	1	1	1-356885-3	STOP, SHEAR	11
-	1	1	1	1	2119805-3	SHEAR HOLDER, FRONT	10
-	1	1	1	1	318059-9	FLOATING SHEAR, FRONT	9
-	1	1	1	1	2-1633930-3	ANVIL, COMBINATION	8
-	-	-	-	-	-	-	7
-	-	-	-	-	-	-	6
-	1	1	1	1	1803080-7	DEPRESSOR, SHEAR	5
-	1	1	1	1	2-238011-7	BLOCK, CRIMPER SPACER	4
-	1	1	1	1	3-1633996-8	CRIMPER, INSULATION SPECIAL	3
-	1	1	1	1	1-455888-7	SPACER, CRIMPER	2
-	1	1	1	1	1-456430-4	CRIMPER, WIRE	1
-77	-7	-6	-5	-2	PART NO	DESCRIPTION	ITEM NO

DIMENSIONS:		TOLERANCES UNLESS OTHERWISE SPECIFIED:		DRAWING NO	
mm	0 PLC ±.05	1 PLC ±.13	2 PLC ±.013	3 PLC ±.013	4 PLC ±.0001
	ANGLES ±.0001	FINISH			
MATERIAL		WEIGHT			

OWN	CHK	DATE	NAME
R.O. WILSON	K.J. STARK	19MAY2014	T. L. ELBIN
		22MAY2014	
		22MAY2014	

SIZE	CAGE CODE	DRAWING NO	RESTRICTED TO
A1	00779	2266257	

Customer Accessible Production Drawing SCALE 1:2 SHEET 1 OF 4 REV C

LOC		DIST		REVISIONS			
P	LTN	DESCRIPTION	DATE	OWN	APVD		
-	-	SEE SHEET 1	-	-	-		

FEED TYPE

PNEUMATIC

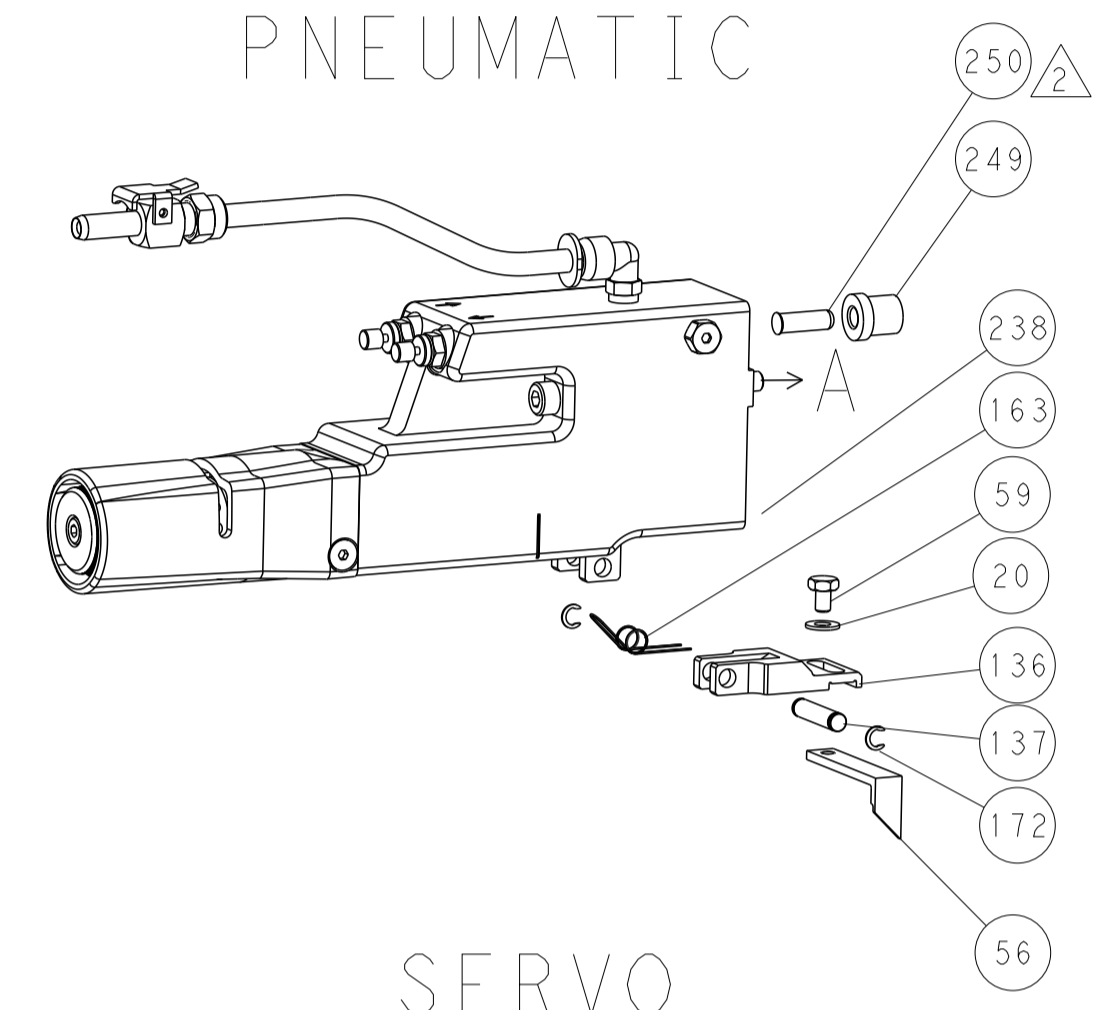

SERVO LATCH PLATE

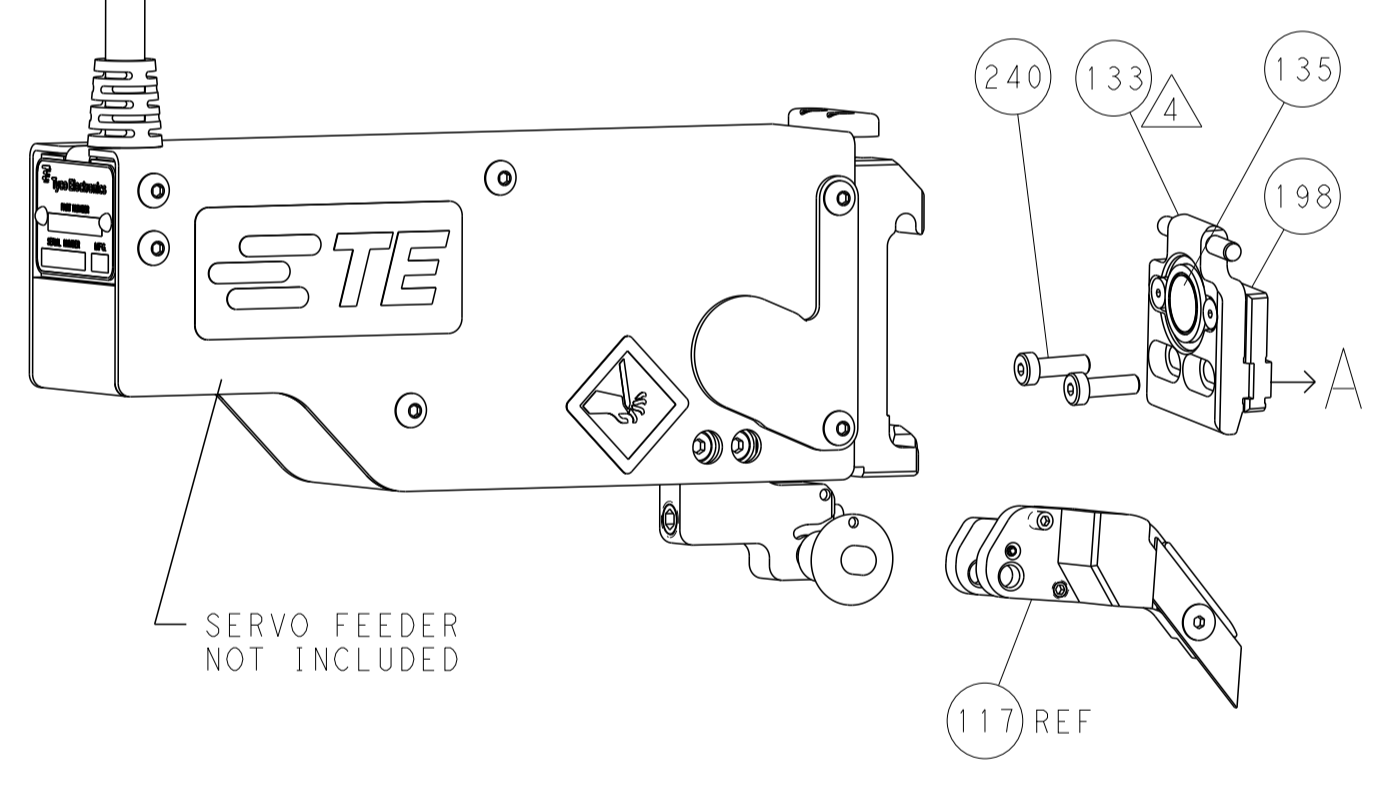

CAM POSITION

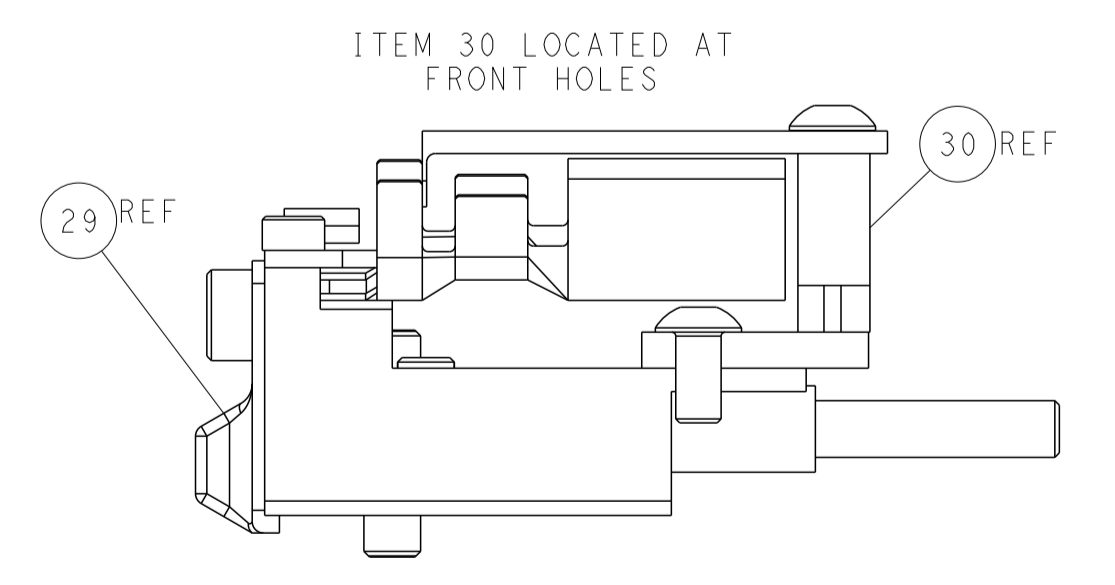
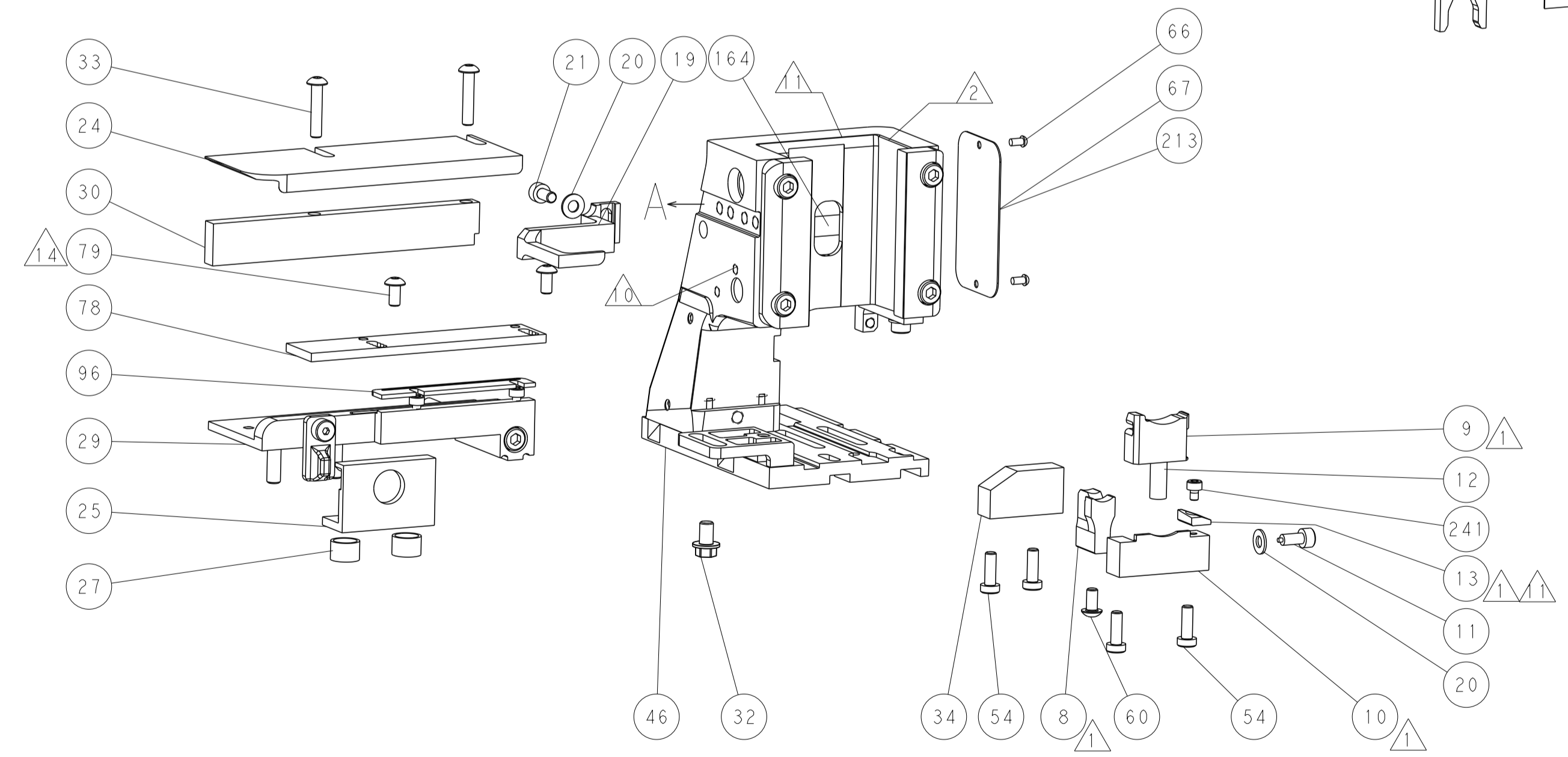
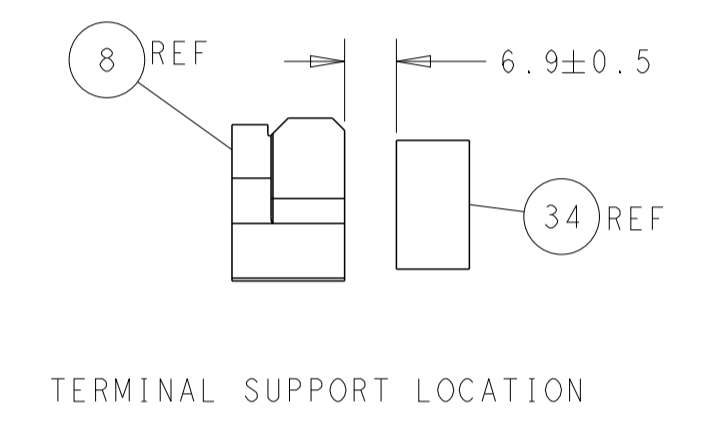
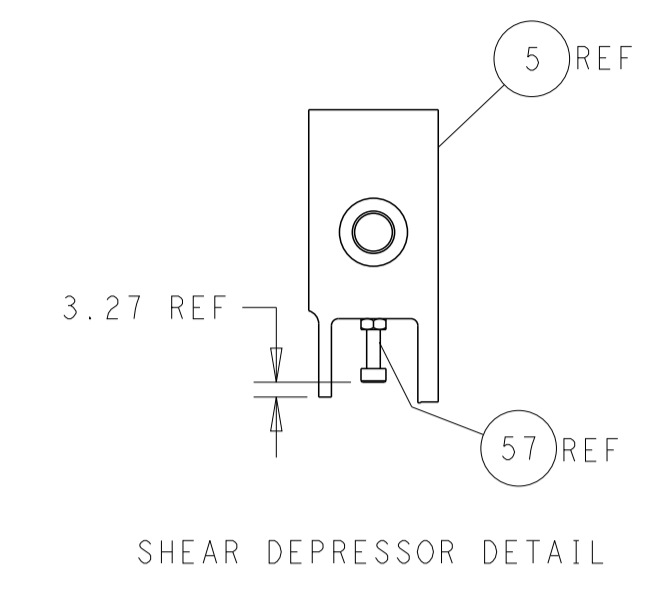
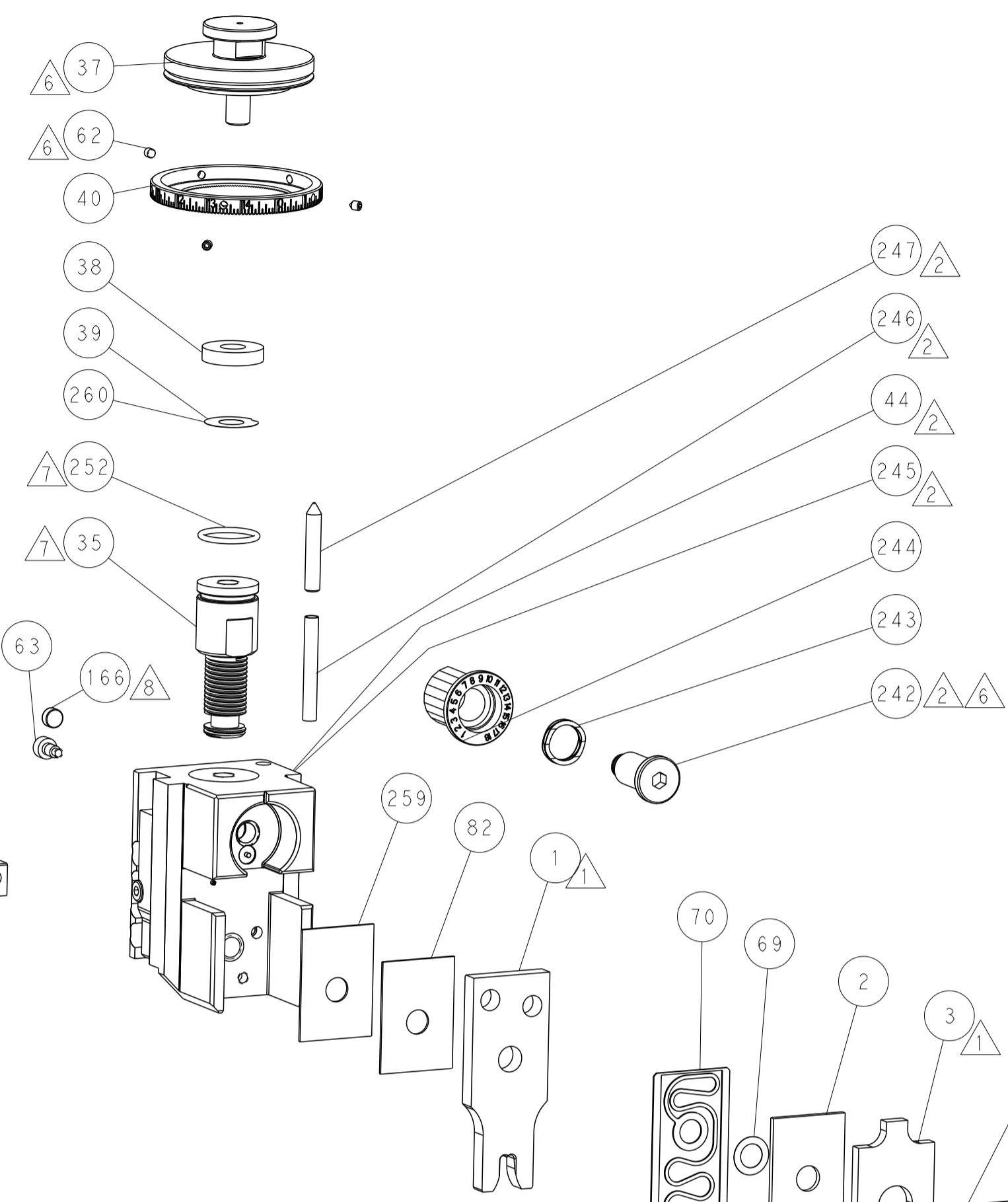
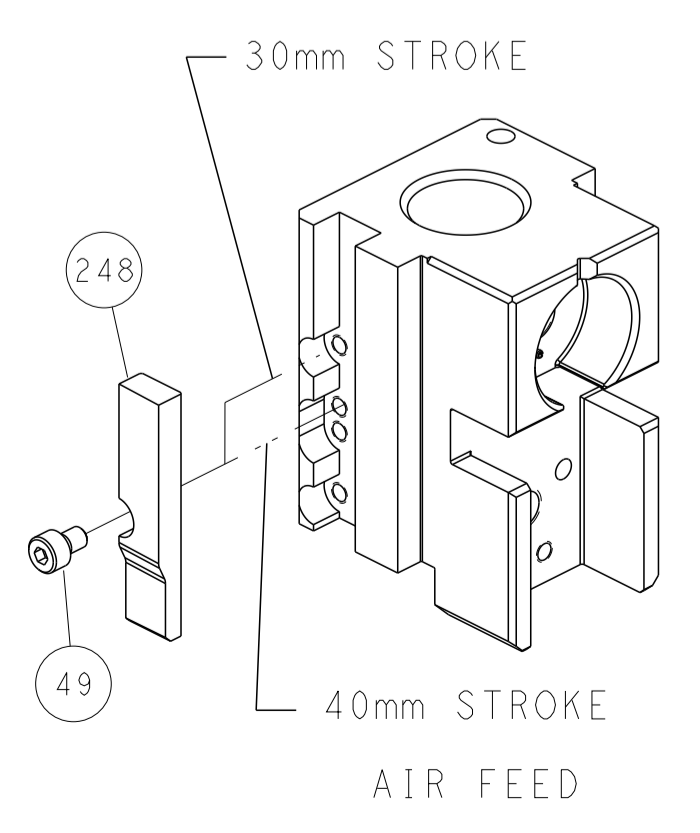

ATLANTIC VERSION
 Shown on sheets 1 of 4 & 2 of 4
 (Pacific version shown on sheets 3 of 4 & 4 of 4)

DIMENSIONS:		TOLERANCES UNLESS OTHERWISE SPECIFIED:		DWN R.O. WILSON 19MAY2014		TE Connectivity	
mm	0 PLC ±0.5	1 PLC ±0.5	2 PLC ±0.13	3 PLC ±0.013	4 PLC ±0.001	APVD T.L. ELBIN 22MAY2014	Harrisburg, PA 17105-3608
MATERIAL:		FINISH:		WEIGHT:		NAME Ocean Side Feed Applicator	
-		-		-		SIZE CAGE CODE DRAWING NO. RESTRICTED TO	
-		-		-		A1 00779 C=2266257	
-		-		-		Customer Accessible Production Drawing SCALE 1:2 SHEET 2 OF 4 REV C	

PACIFIC VERSION TERMINATOR INTERFACE ADAPTER	PART NUMBER	REVISION	DESCRIPTION	FEED TYPE
	2-2266257-2	C	FINE CRIMP HEIGHT ADJUST	PNEUMATIC
	2-2266257-5	C	FINE CRIMP HEIGHT ADJUST	SERVO LATCH PLATE ⁴
	2-2266257-7	C	FINE CRIMP HEIGHT ADJUST	NONE
	7-2266257-7	A	CRIMP TOOLING KIT	-

APPLICATOR DATA		
CRIMP	SIZE	TYPE
WIRE	5.33 mm [.210]	F
INSUL	9.91 mm [.390]	O
APPLICATOR INSTRUCTIONS 408-10389		

TERMINAL DATA: TE TERMINAL		TE CRIMP SPECIFICATION	
TERMINAL NAME: MECON 8 CONTACT			
WIRE STRIP LENGTH 4.34-5.11 mm [1.71-.201 IN]		INSULATION DIAMETER RANGE 	
TERMINAL APPLICATION SPECIFICATION 	114-94285	-	-
TERMINALS APPLIED ¹⁰			
TE TERMINAL	TE TERMINAL	TE SEAL	TE SEAL
2208766-1			1K0972744B
			1949052-1
			CABLE DIAMETER 4.00-5.80mm

WIRE SIZE	CRIMP HEIGHT mm [INCH]	CRIMP HEIGHT REFERENCE SETTING
10.00mm2	3.35+/-0.1 [.132+/- .004]	6.0
6.00mm2	2.80+/-0.1 [.110+/- .004]	11.5



- ¹ RECOMMENDED SPARE PARTS
- ² GREASE BEARING SURFACES LIGHTLY
- 3. LUBRICATE DAILY PER THE APPLICATOR INSTRUCTION SHEET SUPPLIED WITH THE APPLICATOR.
- ⁴ APPLICATOR SPECIFIC DATA TO BE ENTERED INTO BLANK MEMORY CHIP AT ASSEMBLY. SEE BELOW FOR PART NUMBER:
PNEUMATIC FEED WITH "SMART APPLICATOR" CONVERSION: 8-2266257-4
SERVO FEED WITH "FINE CRIMP HEIGHT ADJUST": 8-2266257-5
- 5. ADJUSTMENT OF THE STRIPPER MAY BE REQUIRED WHEN MOVING THE APPLICATOR BETWEEN BENCH AND LEADMAKER APPLICATIONS.
- ⁶ APPLY PART NUMBER 1-23419-5 LOCTITE TO THREADS OF ITEMS 62.
APPLY PART NUMBER 2-23419-6 LOCTITE TO THREADS OF ITEMS 242.
- ⁷ GREASE THREADS, GROOVE AND O-RING ON ITEMS 139 & 152.
- ⁸ MAGNET MUST BE ORIENTED CORRECTLY IN ORDER TO PROPERLY ACTUATE THE COUNTER.
- ⁹ CRIMP HEIGHT REFERENCE SETTING WAS THE SETTING USED WHEN THE APPLICATOR WAS QUALIFIED AT THE FACTORY. ADJUSTMENT MAY BE NECESSARY WHEN RUNNING APPLICATOR IN THE FIELD.
- ¹⁰ TERMINAL PITCH NOT COMPATIBLE WITH MECHANICAL FEED.
- ¹¹ TO CONVERT THE APPLICATOR TO A NON-CARRIER CUTTING STYLE, REMOVE ITEM 13 AND ATTACH TO THE LOCATION ON BACK SIDE OF THE HOUSING. REFER TO INSTRUCTION SHEET FOR ADDITIONAL INFORMATION.
- ¹² THIS APPLICATOR APPLIES TERMINAL WITH A SEAL.
- ¹³ CUT TO LENGTH AT ASSEMBLY.
- ¹⁴ APPLY TORQ-SEAL IN ALLEN SOCKET TO FILL HOLE AFTER SOCKET HEAD HAS BEEN ADJUSTED TO CORRECT HEIGHT AT QUALIFICATION.

16. FOR BEST RESULTS, WIRE MUST BE PLACED INTO WIRE BARREL PRIOR TO CRIMPING.

***WARNING**
ON INSTALLATION, SET WIRE DISC, ITEM 40 TO LARGEST WIRE SIZE SETTING. USE OF SETTINGS BELOW MINIMUM REQUIRED CRIMP HEIGHT SETTING WILL CAUSE DAMAGE TO CRIMP TOOLING.

-	1	1	1	5018030-1	NUT, HEX, REG, RoHS, M3	270
-	1	1	1	1803078-1	SPACER, PRECISION	259
-	1	1	1	2119782-1	FINE ADJUST HEAD ASM, PACIFIC STYLE	251
-	-	-	-	2119640-1	PUSH ROD, AIR FEED	250
-	-	-	-	2079988-1	BUSHING, LCH5-12, MISUMI	249
-	1	1	1	1-22279-3	SPRING, COMPRESSION	246
-77	-27	-25	-22	PART NO	DESCRIPTION	ITEM NO

PACIFIC VERSION
Shown on sheets 3 of 4 & 4 of 4
(Atlantic version shown on sheets 1 of 4 & 2 of 4)

SET UP GAUGE	LOC	DIST	REVISIONS					
2119599-1	A	66	P	LTN	DESCRIPTION	DATE	OWN	APVD
			-	-	SEE SHEET 1	-	-	-

-	1	1	1	2119082-6	CAM, SNAIL, INSULATION ADJUSTMENT	244
-	1	1	1	2079764-1	WASHER, WAVE SPRING, CREST-TO-CREST	243
-	1	1	1	2119083-1	RETAINER, INSULATION DIAL	242
-	1	1	1	7-18023-7	SCR, SKT HD CAP M3 X 4.0	241
-	-	2	-	2168400-6	SHCS, LOW HEAD, RoHS, M5 X 16	240
-	-	-	1	2063440-2	AIR FEED MODULE	238
-	-	1	-	2119740-2	TAG IDENTIFICATION	213
-	-	1	-	1901094-3	SPACER, FEEDER	198
-	-	-	2	21045-3	RING, RETAIN, EXTERN, 3/16 CRESCENT	172
-	1	1	1	994969-1	MAGNET, RARE EARTH HIGH ENERGY	166
-	REF	REF	REF	994970-2	COUNTER, MAGNETIC	164
-	-	-	1	240638-1	SPRING, FEED FINGER	163
-	1	1	1	8-21084-1	O-RING, .801 ID, .070 DIA. MAT.	152
-	-	-	1	2119641-2	FEED CAM, AIR FEED	151
-	1	1	1	2119798-2	DETENT PIN	145
-	1	1	1	2079383-8	SCR, BHSC, RoHS (M4 X 16)	144
-	4	4	4	2168400-5	SHCS, LOW HEAD, RoHS, M4 X 20	143
-	1	1	1	1-2119656-8	APPLICATOR BASIC ASSEMBLY, SF	141
-	1	1	1	2161312-1	RAM, STEPPED, ASIAN STYLE, SIDE FEED	140
-	1	1	1	2119092-2	BOLT, ADJUSTMENT	139
-	-	-	1	3-23627-7	PIN, RETAIN, GRVD, 3/16 X .854	137
-	-	-	1	2119799-1	HOLDER, FEED FINGER, AF	136
-	-	REF	-	SEE NOTE 4	MEMORY CHIP, PROGRAMMED	135
-	-	1	-	1633743-1	SERVO FEED LATCH ASM	133
-	-	REF	-	2119944-1	FEED FINGER ASSEMBLY, SF	117
-	1	1	1	1-690438-0	FRONT STRIP GUIDE	96
-	1	1	1	1803078-1	SPACER, PRECISION	82
-	2	2	2	2079383-4	SCR, BHSC, RoHS (M4 X 8)	79
-	1	1	1	1803096-1	EXTENSION PLATE	78
-	1	1	1	2119956-1	DOCUMENTATION PACKAGE	71
-	1	1	1	2119791-7	DEPRESSOR, WIRE	70
-	1	1	1	2119943-1	WASHER, SPACER	69
-	1	-	1	2119740-1	TAG IDENTIFICATION	67
-	2	2	2	2168078-1	SCREW, DRIVE, RH, RoHS, 2 x .188	66
-	1	1	1	2119793-1	LIMITER, ADJUSTMENT BOLT	63
-	3	3	3	992763-5	SCR, SET, SOC, CONE POINT, M3 X 4.0	62
-	-	-	1	5-18022-5	SCR, HEX HD CAP, M4 X 6.0	59
-	1	1	1	1-2168083-3	SCR, SKT HD CAP, RoHS, M3 X 16	57
-	-	-	1	1338683-8	FEED PAWL	56
-	2	2	2	1-2168083-0	SCR, SKT HD CAP, RoHS, M4 X 10	53
-	1	1	1	5018030-1	NUT, HEX, REG, RoHS, M3	52
-	1	1	1	1-811242-0	BUMPER, HOLD DOWN	51
-	1	1	1	690753-2	SPACER, TONKER	50
-	-	-	1	18023-9	SCR, SKT HD CAP M4 X 6.0	49
-	1	1	1	2079383-7	SCR, BHSC, RoHS (M8 X 25)	41
-	1	1	1	2119645-1	DISC, NUMBERED FA WIRE ADJUSTMENT	40
-	1	1	1	2119957-1	APPLICATOR SHIM PACK	39
-	1	1	1	2119644-3	RAM WASHER, PRECISION	38
-	1	1	1	5-1752356-0	SUPPORT, TERMINAL	34
-	2	2	2	2079383-5	SCR, BHSC, RoHS (M4 X 20)	33
-	1	1	1	2161328-1	HEX HEAD, FLANGED, M5 X 8mm LONG	32
-	1	1	1	1320908-7	SPACER, STRIP GUIDE	30
-	1	1	1	2119959-5	ASSEMBLY, STRIP GUIDE	29
-	1	1	1	455888-3	SPACER, CRIMPER	28
-	2	2	2	22283-1	SPRING, COMPRESSION	27
-	1	1	1	240792-1	DRAG, TERMINAL	25
-	1	1	1	1320928-4	STRIP GUIDE	24
-	1	1	1	2168083-2	SCR, SKT HD CAP, RoHS, M4 X 8.0	21
-	3	3	3	1-18028-2	WASHER, FLAT, REG M4	20
-	1	1	1	1803013-1	STRIPPER, SIDE FEED	19
-	1	1	1	2119806-1	INSERT, SHEAR	13
-	1	1	1	4-22280-7	SPRING, COMPRESSION	12
-	1	1	1	1-356885-3	STOP, SHEAR	11
-	1	1	1	2119805-3	SHEAR HOLDER, FRONT	10
-	1	1	1	318059-9	FLOATING SHEAR, FRONT	9
-	1	1	1	2-1633930-3	ANVIL, COMBINATION	8
-	-	-	-	-	-	7
-	-	-	-	-	-	6
-	1	1	1	1803080-7	DEPRESSOR, SHEAR	5
-	1	1	1	2-238011-7	BLOCK, CRIMPER SPACER	4
-	1	1	1	3-1633996-8	CRIMPER, INSULATION SPECIAL	3
-	1	1	1	1-455888-7	SPACER, CRIMPER	2
-	1	1	1	1-456430-4	CRIMPER, WIRE	1
-77	-27	-25	-22	PART NO	DESCRIPTION	ITEM NO

DIMENSIONS:		TOLERANCES UNLESS OTHERWISE SPECIFIED:		APPROVED:		DATE:	
mm	0 PLC ±.5	1 PLC ±.13	2 PLC ±.013	3 PLC ±.001	4 PLC ANGLES ±.0001	FINISH	
MATERIAL:		FINISH:		WEIGHT:		SCALE:	
Customer Accessible Production Drawing		SCALE: 1:2		SHEET 3 OF 4		REV C	

LOC		DIST		REVISIONS			
A	66	P	LTM	DESCRIPTION	DATE	OWN	APVD
		-		SEE SHEET 1			

FEED TYPE PNEUMATIC

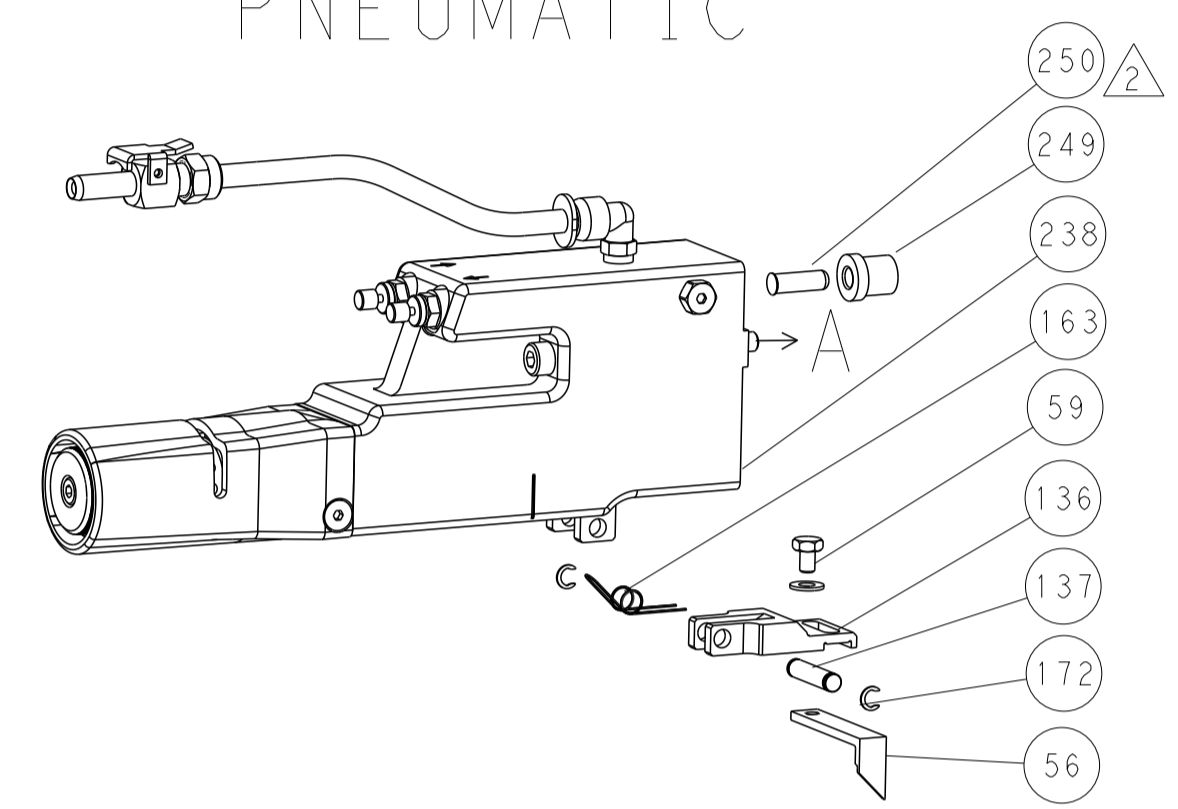

SERVO LATCH PLATE

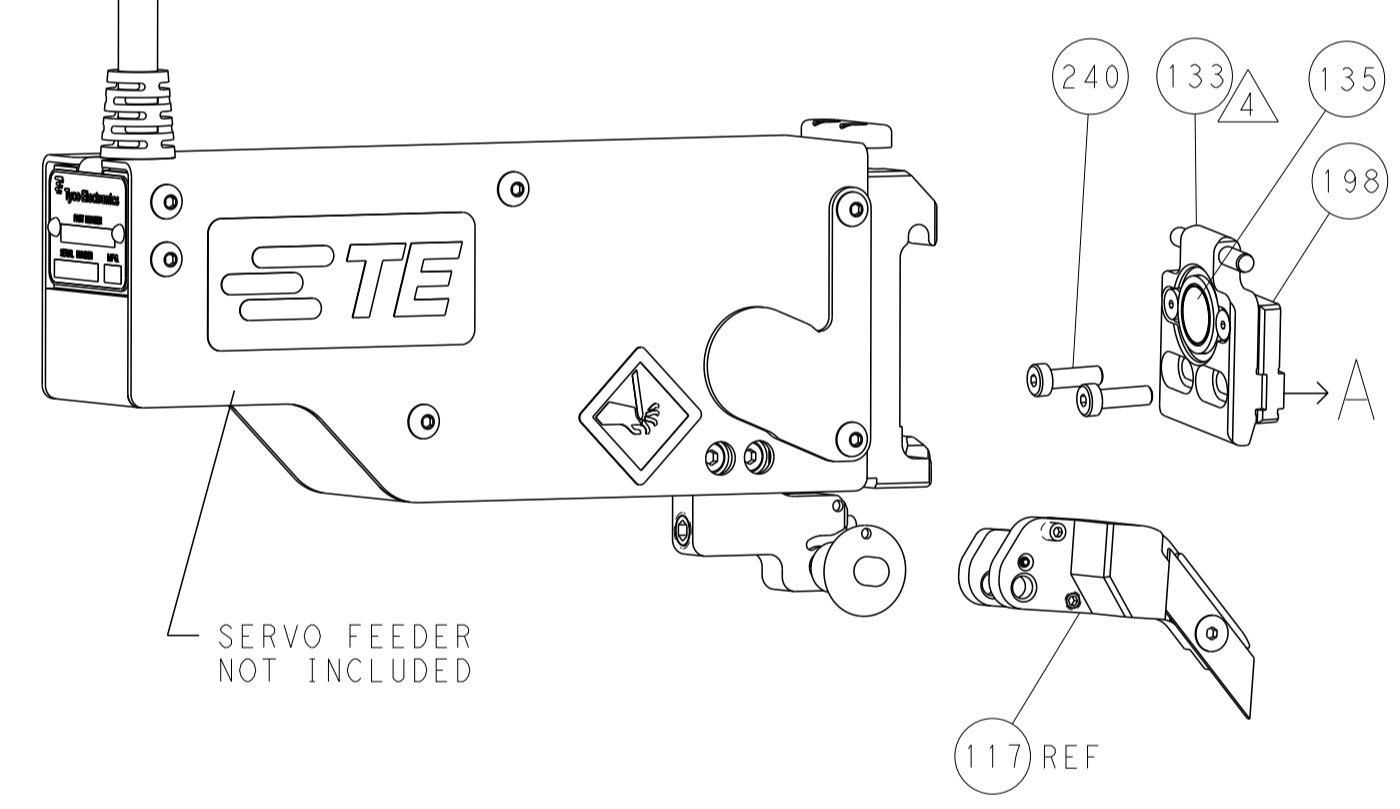

CAM POSITION

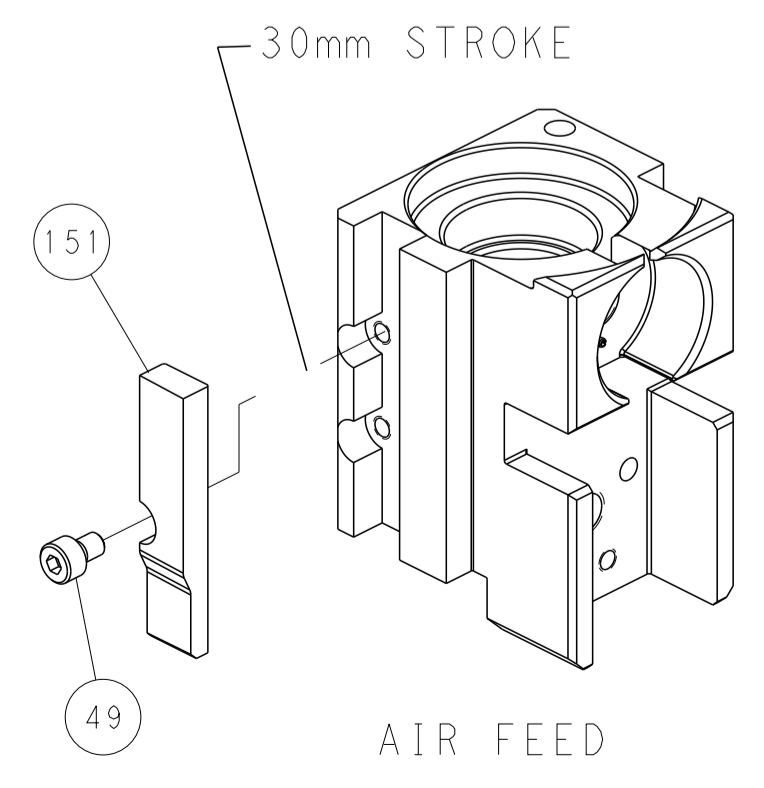

AIR FEED

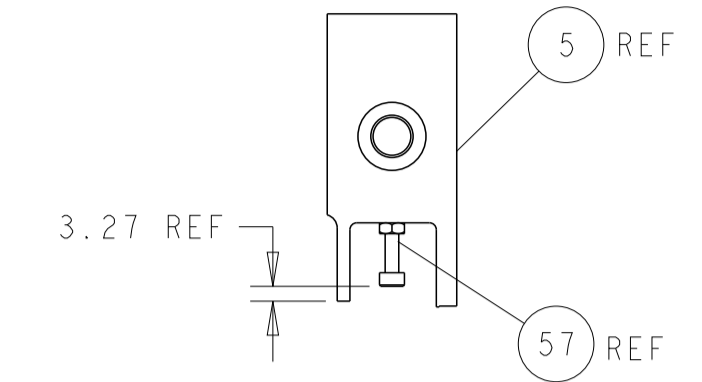
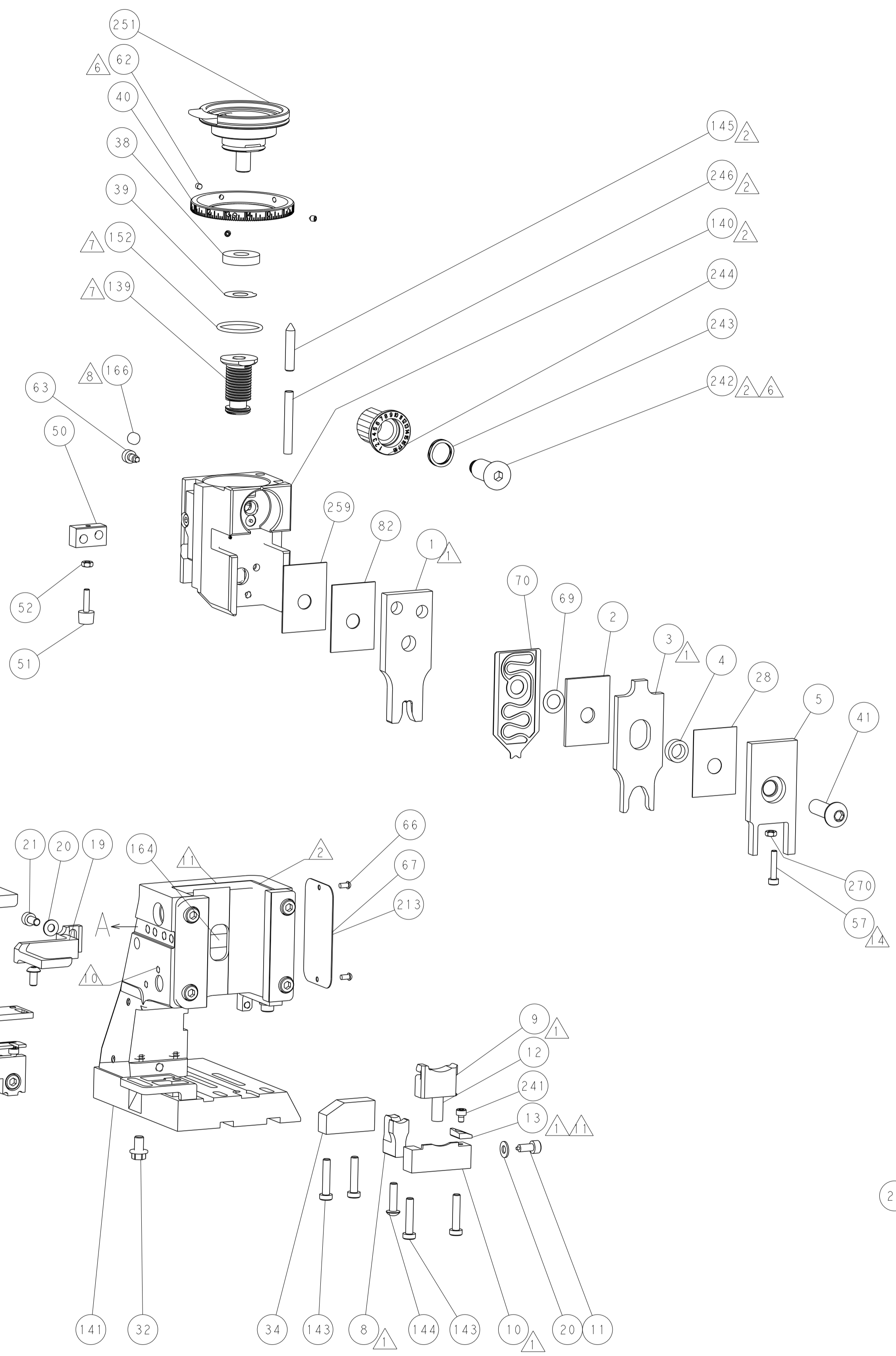

SHEAR DEPRESSOR DETAIL

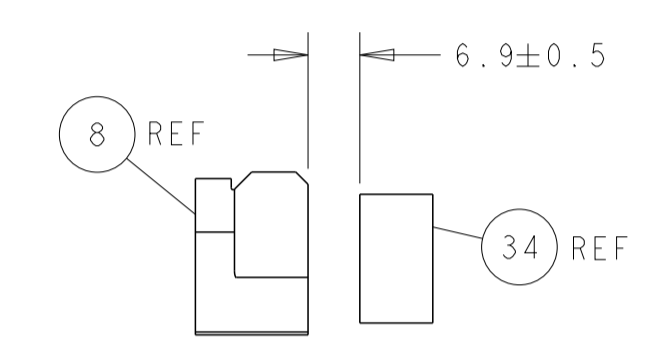

TERMINAL SUPPORT LOCATION

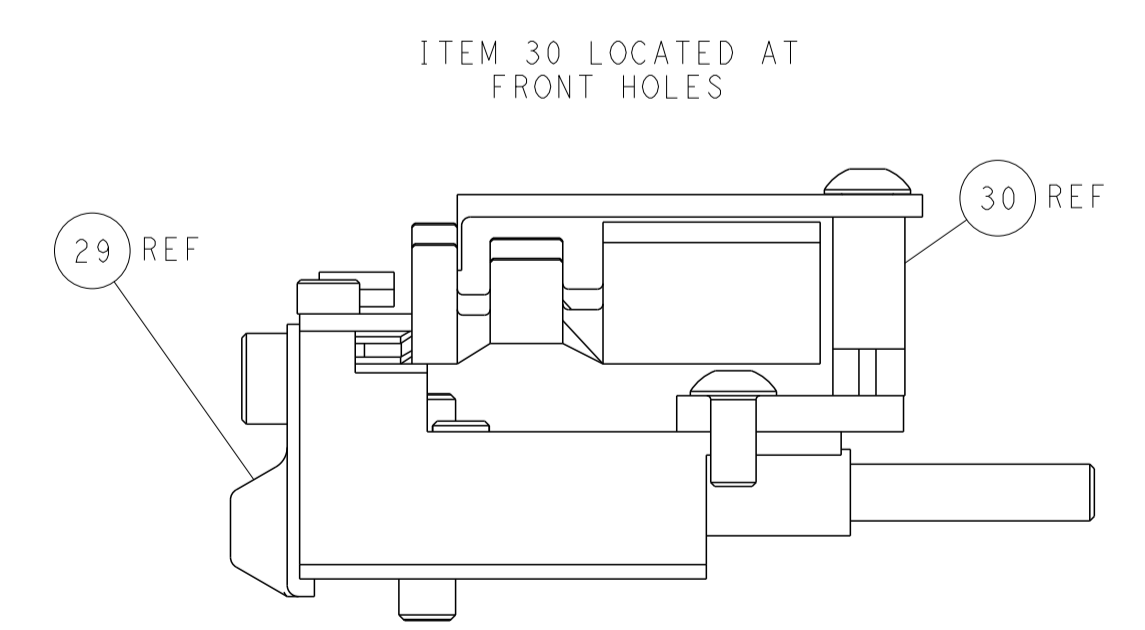

FEED TRACK POSITION
GUIDE BY INSULATION BARREL

PACIFIC VERSION
 Shown on sheets 3 of 4 & 4 of 4
 (Atlantic version shown on sheets 1 of 4 & 2 of 4)

<small>THIS DRAWING IS UNPUBLISHED. RELEASED FOR PUBLICATION 20. COPYRIGHT 20 BY TYCO ELECTRONICS CORPORATION. ALL RIGHTS RESERVED.</small>		DWN: R. O. WILSON CHK: K. J. STAKEM APVD: T. L. ELBIN	19MAY2014 22MAY2014 22MAY2014	TE Connectivity Harrisburg, PA 17105-3608
DIMENSIONS: mm		TOLERANCES UNLESS OTHERWISE SPECIFIED: 0 PLC ±.5 1 PLC ±0.5 2 PLC ±0.13 3 PLC ±0.013 4 PLC ±0.001 ANGLES ±.0001		NAME: Ocean Side Feed Applicator PRODUCT SPEC: - APPLICATION SPEC: -
MATERIAL: - FINISH: -		WEIGHT: - SCALE: 1:2	SIZE: A1 CAGE CODE: 00779 DRAWING NO: C-2266257	RESTRICTED TO: - SHEET 4 OF 4 REV C