

Features

- 11,000 counts LCD display
- Conversion rate : 4 times/s
- Full automatic measurement
 - *Voltage measurement:
110.00mV – 1000.0V
 - *Current measurement: $\mu\text{A}/\text{mA}/\text{A}$
 - *Resistance measurement:
110.00 Ω – 110.0M Ω
 - *Capacitance measurement:
11.000nF – 110.00mF(12.5sec)
(Taiwan patent no.: 453443)
 - *Frequency counter:
1.1000KHz – 110.00MHz
- Current modes for clamp meter
- Diode measurement
- Continuity check
- ADP mode with independent reference voltage
- Temperature mode with internal scale conversion circuit from $^{\circ}\text{C}$ to $^{\circ}\text{F}$
- VAHZ function
(Taiwan patent no.: 510502)
- Relative function
- Zero function in manual DCA mode
- Data hold function
- MAX/MIN function
- SHIFT function

- Band-gap reference voltage output
- High crest factor signal detection
(Taiwan patent no.: 234661)
- CE selection
- On-chip independent OPAMP
- Serial data output (RS232 format)
- LCD segment check when power on
- Auto power off with idle time selection
- Sleep output
- Re-power on
- On-chip buzzer driver
- 3V DC power supply
- Low battery detection for 3V or 9V battery
- Back light function

Description

ES51911 is an integrated analog-to-digital converter (ADC) with 11,000 counts LCD display, automatic range selection, and 3V DC power supply. Automatic range selection is provided for voltage (AC/DC) measurement, resistance measurement, current measurement, capacitance measurement, and frequency counter. Expensive and bulky mechanical range switches are not required. Other features include relative value display, zero-offset removing feature in manual DCA mode for clampmeter, data holding, maximum and minimum holding, diode measurement, temperature measurement, continuity checking, low battery detection, auto power off, re-power on, and RS232 data output.

Application

Digital multimeter

Clamp meter

Thermometer

Pin Assignment

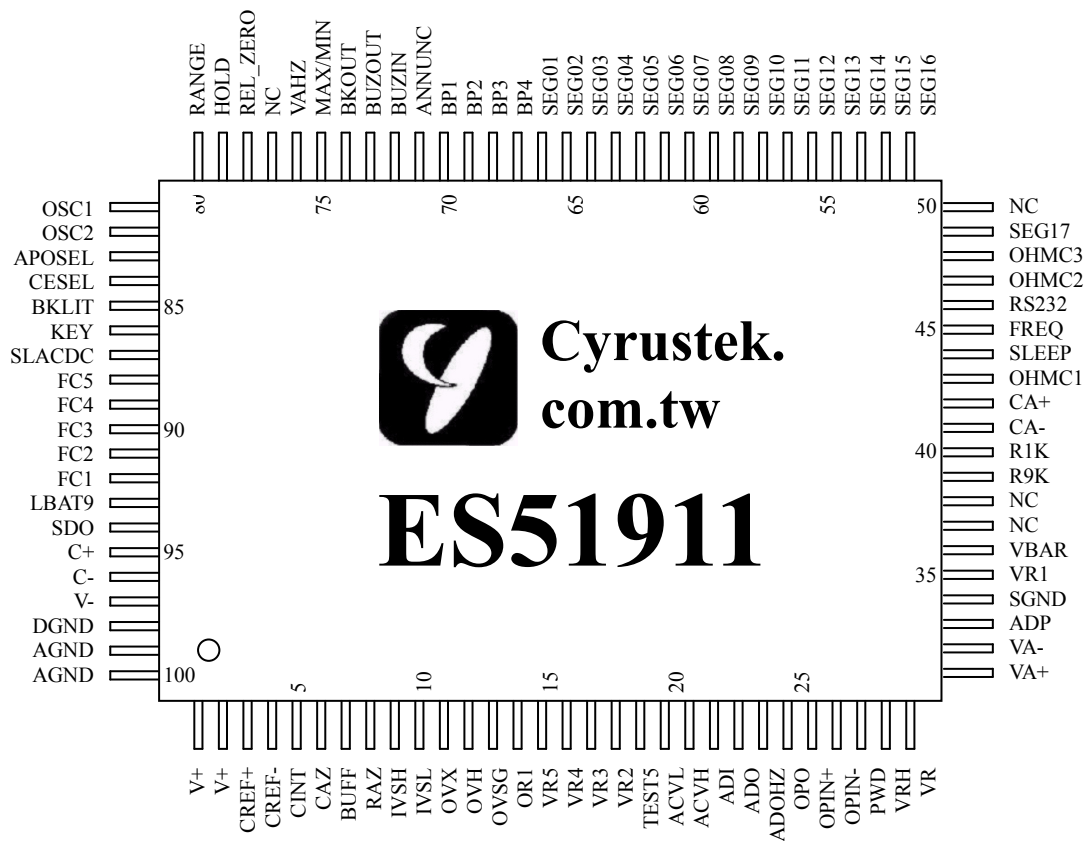



Pin Description

Pin No	Symbol	Type	Description
1	V+	O	Output of on-chip DC-DC converter.
2	V+	O	Output of on-chip DC-DC converter.
3	CREF+	I/O	Positive connection for reference capacitor.
4	CREF-	I/O	Negative connection for reference capacitor.
5	CINT	O	Integrator output. Connect to integral capacitor
6	CAZ	I	Auto-zero capacitor connection.
7	BUFF	O	Buffer output pin. Connect to integral resistor
8	RAZ	O	Buffer output pin in high-speed mode. Connect to high-speed integral resistor.
9	IVSH	I	Current measurement input for 1100 μ A, 110mA and 11A modes.
10	IVSL	I	Current measurement input for 110 μ A, 11mA.
11	OVX	I	Input high voltage for resistance measurement
12	OVH	I	Output connection for resistance measurement
13	OVSG	I	Sense low voltage for resistance measurement
14	OR1	O	Reference resistor connection for 110.00 Ω range
15	VR5	O	Voltage measurement \div 10000 attenuator(1000.0V)
16	VR4	O	Voltage measurement \div 1000 attenuator(110.00V)
17	VR3	O	Voltage measurement \div 100 attenuator(11.000V)
18	VR2	O	Voltage measurement \div 10 attenuator(1.1000V)
19	TEST 5	I/O	Test pin
20	ACVL	O	DC signal low input in ACV/ACA mode. Connect to negative output of external AC to DC converter.
21	ACVH	O	DC signal high input in ACV/ACA mode. Connect to positive output of external AC to DC converter.
22	ADI	I	Negative input of internal AC to DC OP Amp.
23	ADO	O	Output of internal AC to DC OP Amp.
24	ADOHZ	I	Frequency input under voltage/current mode, offset to AGND.
25	OPO	O	Output of internal independent OP Amp.
26	OPIN+	I	Positive input terminal of on-chip independent OP Amp.
27	OPIN-	I	Negative input terminal of on-chip independent OP Amp.
28	PWD	I	Power-down enable for on-chip independent OP Amp.
29	VRH	O	Output of band-gap voltage reference. Typically -1.23 V
30	VR	I	Reference input voltage connection. Typically -100 mV
31	VA+	I	For ADP mode. De-integrating voltage positive input. The input should be higher than VA-.
32	VA-	I	For ADP mode. De-integrating voltage negative input. The input should be lower than VA+.
33	ADP	I	Measurement input in ADP mode.
34	SGND	G	Signal Ground.
35	VR1	I	Measurement input.
36	VBAR	I	In capacitance mode, a compensation capacitor is connected. In temperature mode, it is used to control decimal point. In μ A or mA modes, it is used to control the ' μ ' or 'm' sign.
37	NC		
38	NC		
39	R9K	O	Connect to a precise 9K Ω resistor for capacitor measurement.
40	R1K	O	Connect to a precise 1K Ω resistor for capacitor measurement.
41	CA-	I/O	Negative auto-zero capacitor connection for capacitor measurement
42	CA+	I/O	Positive auto-zero capacitor connection for capacitor measurement
43	OHMC1	O	Filter capacitor connection for resistance mode.



44	SLEEP	O	Sleep mode indicator, asserts low in SLEEP mode.
45	FREQ	I	Frequency counter input, offset V-/2 internally by the chip.
46	RS232	I	Assert low to enable serial data output.
47	OHMC2	O	Filter capacitor connection for resistance mode.
48	OHMC3	O	Filter capacitor connection for resistance mode.
49	SEG17	O	LCD segment line 17
50	NC		
51 - 66	SEG16 – SEG01	O	LCD segment line 01 – 16
67	BP4	O	LCD backplane 4
68	BP3	O	LCD backplane 3
69	BP2	O	LCD backplane 2
70	BP1	O	LCD backplane 1
71	ANNUNC	O	Square wave output at the backplane frequency, synchronized to BP1. ANNUNC can be used to control display annunciator. Connect a LCD segment to ANNUNC to turn it on; connect an LCD segment to its backplane to turn it off.
72	BUZIN	I	Pull to V- to enable the BUZOUT.
73	BUZOUT	O	Outputs a 2KHz audio frequency signal for driving piezoelectric buzzer when BUZIN is low.
74	BKOUT	O	If BKLIT function is enabled, this pin will change from -3V to +3V For 60 sec, once press BKLIT pin again within 60 sec, this pin will Change back to -3V.
75	MAXMIN	I	Pulse to V- to enable MAX/MIN function.
76	VAHZ	I	Pulse to V- to enable VAHZ mode.
77	NC		
78	REL_ZERO	I	Pulse to V- to enable Relative function or Zero function.
79	HOLD	I	Pulse to V- to enable HOLD function.
80	RANGE	I	Pulse to V- to enable manual mode and manual range selection.
81	OSC1	I	Crystal oscillator input connection
82	OSC2	O	Crystal oscillator output connection
83	APOSEL	I	Idle time selection for auto power off feature.
84	CESEL	I	CE selection feature control pin.
85	BKLIT	I	Back light function. Pulse low to set BKOUT pin output.
86	KEY	I	Pulse to V- to change mode. In ADP mode, if this pin is connected to V-, the buzzer output will be off when the ADP input overflows.
87	SLACDC	I	Select initial state. Please refer to page 13
88	FC5	I	Switch 5 for function selection.
89	FC4	I	Switch 4 for function selection.
90	FC3	I	Switch 3 for function selection.
91	FC2	I	Switch 2 for function selection.
92	FC1	I	Switch 1 for function selection.
93	LBAT9	I	Low battery configuration. If 3V battery is used, connect it to AGND. The default low-battery threshold voltage is -2.3V. If 9V battery is Used, the low battery annunciator is displayed when the voltage of this pin is less than VRH (-1.2V)
94	SDO	O	RS232 compliant serial data output.
95	C+	O	Positive capacitor connection for on-chip DC-DC converter.
96	C-	O	Negative capacitor connection for on-chip DC-DC converter.
97	V-	P	Negative supply voltage. Connecting to 3V battery negative terminal.
98	DGND	P/G	Digital ground. Connecting to 3V battery positive terminal.
99	AGND	P/G	Analog ground.
100	AGND	P/G	Analog ground.

Absolute Maximum Ratings

Characteristic	Rating
Supply Voltage (V- to AGND)	-4V
Analog Input Voltage	V- -0.6 to V+ +0.6
V+	V+ \geq (AGND/DGND+0.5V)
AGND/DGND	AGND/DGND \geq (V- -0.5V)
Digital Input	V- -0.6 to DGND +0.6
Power Dissipation. Flat Package	500mW
Operating Temperature	0°C to 70°C
Storage Temperature	-25°C to 125°C

Electrical Characteristics

TA=25°C, V- = -3V

Parameter	Symbol	Test Condition	Min.	Typ.	Max	Units
Power supply	V-		-3.5	-3.0	-2.2	V
Operating supply current	I _{DD}	Normal operation	—	1.8	2.0	mA
In DCV mode	I _{SS}	In sleep mode	—	2.5	5	μA
Voltage roll-over error	REV	10MΩ input resistor	—	—	±0.05	%F.S. ¹
Voltage nonlinearity	NLV	Best case straight line	—	—	±0.05	%F.S
Input Leakage			-10	1	10	pA
Low battery flag voltage		V- to AGND	-2.4	-2.3	-2.2	V
Zero input reading		10MΩ input resistor	-000	000	+000	counts
Reference voltage	V _{REF}	100KΩ resistor between VRH and AGND	-1.33	-1.23	-1.13	V
Peak to peak backplane drive voltage		-3.5V \leq V \leq -2.2V	3.1	3.2	3.3	V
Counter time base period		f _{OSC} = 4MHZ	—	1	—	sec
Open circuit voltage for 110Ω range		Ω and Continuity Mode	—	-3.0	—	V
Open circuit voltage for Ω measurement (except 110Ω)			-0.38	-0.34	-0.30	V
Internal pull-high to 0V current		Between V- pin and HOLD, RANGE, KEY, FC1~FC5, BKLIT, MAXMIN	—	1.2	—	μA
		Between V- pin and RS232	—	11	—	
Internal pull-low to V- current		Between GND Pin and PWN		1.5		μA
AC frequency response at 1.1000V range		±1%	—	40-400	—	HZ
		±5%	—	400-2000	—	
Sensitivity in VAHZ mode		Input from ADOHZ Duty cycle=50%	600			mV(Vpp)

Sensitivity in Frequency mode		Input from FREQ Duty cycle=50%	600			mV(Vpp)
Reference voltage temperature coefficient	TC_{RF}	100K Ω resistor Between VRH 0°C<TA<70°C	—	50	—	ppm/°C
Capacitance measurement accuracy ²		11nF			1.5	%
					15	Digits
		110nF/1.1 μ F			1.0	%
					10	Digits
		11 μ F/110 μ F/1.1mF			1.0	%
			5	Digits		
		11mF/110mF			1.5	%
					5	Digits

Note:

1.Full Scale

2.Above specification from 11nF to 1.1 μ F ranges are specified under REL mode.

Function Description

1. Operating Modes

1.1 Voltage Measurement

A re-configurable voltage divider automatically provides a suitable range in voltage measurement mode. The following table summarizes the full-scale ranges in each configuration.

Configuration	Full Scale Range	Divider Ratio	Resister Connection
VR1	110.00mV	1	R1
VR2	1.1000V	1/10	R2 / (R1+R2)
VR3	11.000V	1/100	R3 / (R1+R3)
VR4	110.00V	1/1000	R4 / (R1+R4)
VR5	1100.0V	1/10000	R5 / (R1+R5)

Note: 110.00mV range only exists in manual mode.

1.1.2 CE selection

ES51911 has a CE selection feature archived by configuring an CESEL pin. If pin CESEL is connected to DGND or floating, ES51911 will have a 610.0V overflow level in DC and AC 1100.0V ranges. If pin CESEL is connected to V-, ES51911 will have a 1010.0V overflow level in DC and AC 1100.0V ranges. The meter will Show OL when the measuring signal reaches the overflow level. The configuration of CESEL is listed below.

CESEL	DCV	ACV
V-	1010.0V	1010.0V
DGND or floating	610.0V	610.0V

1.1.3 HCF signal detection

ES51911 provides detection of high-crest-factor (HCF) signal in ACV mode. When this function is enabled, ES51911 senses the signal and determines it as HCF if the V_{pp} is large enough. Once the signal is determined as HCF, ES51911 will jump up one measuring range regardless of current measurement value. It takes 60ms to jump one range up. The jumping up process will continue until the maximum range is reached. With HCF detection, a more accurate result could be obtained. For example, when a input signal with $V_{pp}=500V$, $V_{rms}=100V(CF=5)$ was applied, traditional 4000 counts DMMs might stay at 400V range but shows counts with the amount of error up to 10% or even bigger. The error rises from limited input/output swing at internal ADC. With HCF detection, DMM will stay at 4000V and exhibits more accurate results.

In addition to accuracy improvement, HCF will speed up the measuring process for high voltage signals. For example, a 1000Vrms is applied, ES51911 will take about 180ms (3 HCF jumps) to enter 1100.0 V range. And it takes 1 or 2 measuring processes to obtain the stable result. Thus a stable LCD reading could be obtained within 1 sec.

In determining whether the input signal is HCF, ES51911 senses the signal at VR1 for fast response. However if a signal consists of a small ac part and a large enough dc part, ES51911 might incorrectly treat it as HCF. This could incur range looping phenomenon, i.e., the measurement could not settle to a specific range.

1.1.4 The true RMS-to-DC conversion with ES636

If ES636 is used for true RMS-to-DC measurement, the test circuit is shown in Figure 1. Make ADO and ADI pin short, and TEST5 pin keeps float. Connect OVSG pin to AGND through a switch in ACV measurement mode.

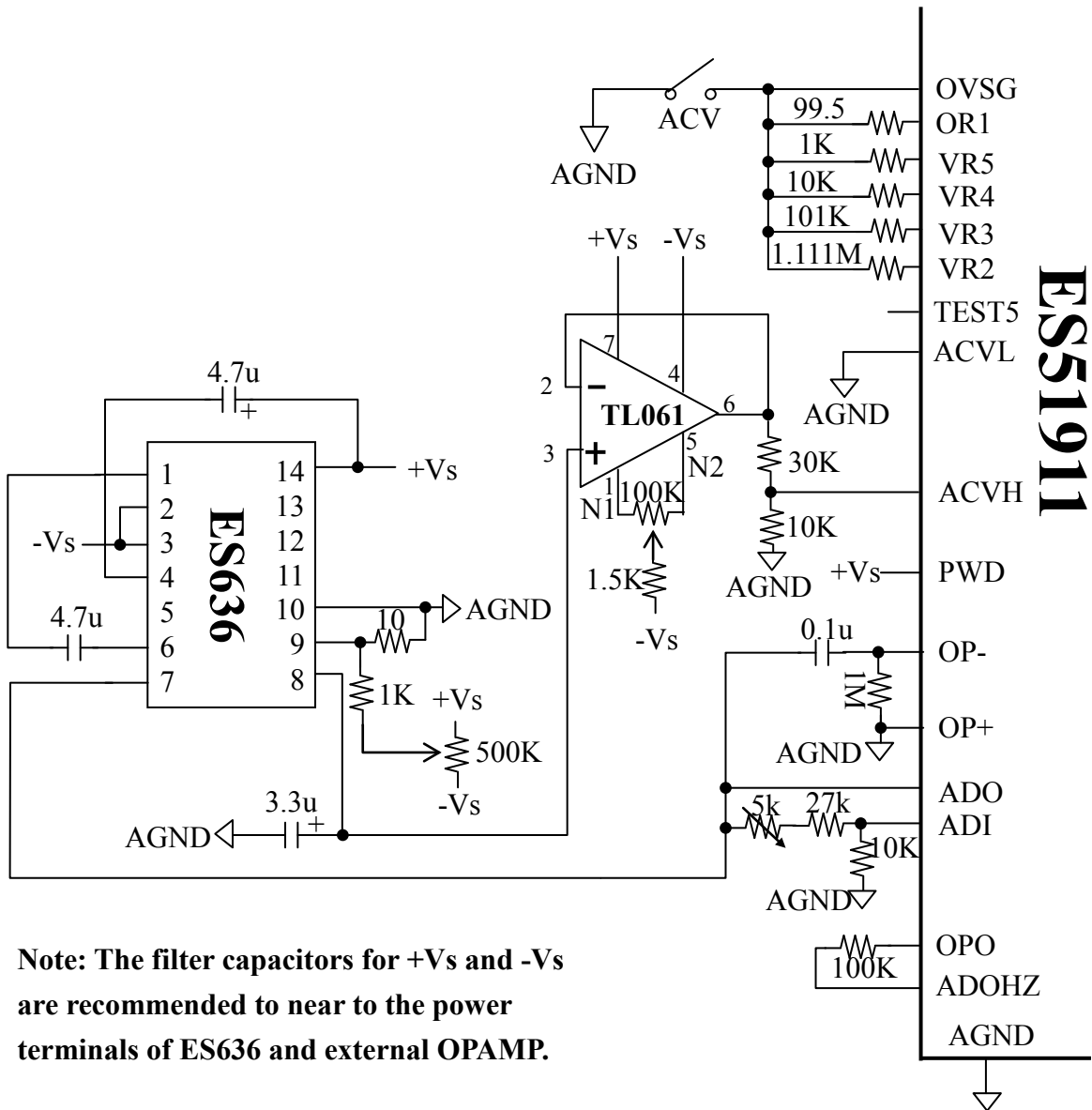

Note: The filter capacitors for +Vs and -Vs are recommended to near to the power terminals of ES636 and external OPAMP.

Figure 1. The true RMS-to-DC conversion with ES636

1.2 Resistance Measurement

A re-configurable divider automatically provides a suitable full-scale range in resistance measurement mode. The following table summarizes the full-scale ranges and the reference resistors in each configuration. In 110.0M Ω , the maximum counting number is 1100 counts and the resolution is 0.1M Ω . So the full scale becomes 110.0M Ω .

Configuration	Full Scale Range	Divider Ratio	Resister Connection
OR1	110.00 Ω	R6	100 Ω
OR2	1.1000K Ω	R5	1K Ω
OR3	11.000K Ω	R4	10K Ω
OR4	110.00K Ω	R1 // R3	100K Ω
OR5	1.1000M Ω	R1 // R2	1M Ω
OR6	11.000M Ω	R1	10M Ω
OR7	110.0M Ω	R1	10M Ω

1.3 Current measurement

ES51911 has 2 automatic and 1 manual current measurement modes for multimeter and 5 manual current measurement modes for clampmeter. The following table summarizes the full-scale range of each mode. When ES51911 operate in the current measurement modes for multimeter, It takes high input from pin IVSH or IVSL, low input from pin SGND and reference voltage from pin VR. When ES51911 operate in the current measurement modes for Clampmeter, It takes high input from pin ADP, low input from pin SGND and reference voltage from pins VA+ and VA-. The test circuits are shown in page 27-28.

Mode	Range Selection	Full Scale	Designed for
Automatic Mode 1	μ A	110.00 μ A / 1100.0 μ A	Multimeter
Automatic Mode 2	mA	11.000mA / 110.00mA	Multimeter
Manual Mode 1	A	11.000A	Multimeter
Manual Mode 2	A	1.1000A	Clampmeter
Manual Mode 3	A	11.000A	Clampmeter
Manual Mode 4	A	110.00A	Clampmeter
Manual Mode 5	A	1100.0A	Clampmeter
Manual Mode 6	A	11000A	Clampmeter

Note:

1. In Manual DC current measurement modes for clampmeter, ES51911 provides Zero function for offset removing.
2. In Automatic model1 and Automatic mode2, the pin VBAR is used to control the display of “ μ ” and “m” sign on the LCD panel. If pin VBAR is floating or connected to DGND, the “ μ ” and “m” sign will be displayed. If pin VBAR is connected to V-, the “ μ ” and “m” sign will not be displayed.

1.4 Capacitance Measurement

The following table summarizes the eight ranges of capacitance measurement mode.

Configuration	Full Scale Range	Resistance Ratio
C1	11.000nF	R1 // R2
C2	110.00nF	R1 // R3
C3	1.1000uF	R4
C4	11.000uF	-
C5	110.00uF	-
C6	1.1000mF	-
C7	11.000mF	-
C8	110.00mF	-

Note:

1. In order to obtain an accurate reading, a capacitor must be discharged before measurement begins. The chip has a built-in discharge mode to automatically discharge the capacitor. In discharge mode, the LCD displays **ds.C**
2. Discharging through the chip is quite slow. We recommend the user to discharge the capacitor with some other apparatus.

1.5 Continuity Check

Continuity check shares the same configuration with 110.00Ω manual resistance measurement mode, but with buzzer output to indicate continuity. The buzzer generates a 2KHz sound whenever the digit number is less than 30Ω. The short circuit detection is more sensitive and the response time is less than 10ms.

1.6 Diode Measurement

Diode measurement mode shares the same configuration with 1.1000V manual voltage measurement mode.. The buzzer generates a 2KHz sound whenever the digit number is less than 30mV. The short circuit detection is more sensitive and the response time is less than 10ms.

1.7 Frequency counter

The time base of the frequency counter is derived from an external crystal oscillator by

$$T_{\text{counter}} = \frac{4,000,000}{F_{\text{osc}}}$$

where F_{osc} is the frequency of the crystal oscillator. Thus, the counter has a 1-second time base when a 4MHz oscillator is used. The frequency counter can select the proper range automatically or manually. Auto-range operation extends over six decades, from 1111Hz to 110.00MHz. The following table summarizes the full-scale range of the frequency counter.

Range	Full Scale
FR1 ^{1,2}	11.1 – 111.1Hz
FR1 ²	112 – 1111Hz
FR2	11.000KHz
FR3	110.00KHz
FR4	1.1000MHz
FR5	11.000MHz
FR6	110.00MHz

NOTE:

¹In the range of FR1, if input frequency is less than 11.1Hz, ES51911 will show **0.0Hz**.

²When the reading is more than 111.1Hz, the resolution becomes 1Hz.

1.8 Temperature measurement mode

Temperature measurement mode takes input signal from ADP pin and reference voltage from (VA+ - VA-). ES51911 has a built-in °C-to-°F scale translation circuit, and only needs an external °C scale application circuit. The application circuit for °F scale is not required. In temperature measurement mode, the default range is 1100.0 °C or °F. VBAR pin is used to control the second decimal point (DP2) on the LCD panel. When VBAR is LOW, DP2 is turned on and the first decimal point (DP1) is turned off.

1.9 Auto power off and Idle Time selection

ES51911 has a default auto power off function. If the meter is idle for more than the given Idle Time, the chip automatically turns the power off. The Idle Time to trigger the auto power off function is determined by pin 'APOSEL'. If pin APOSEL is connected to V-, the Idle Time will be set to 30 minutes. If pin APOSEL is connected to DGND or floating, the Idle Time will be set to 15 minutes. When APO happens, the state of the meter is saved. The APO sign on the LCD panel indicates whether the auto power off is enabled or not. In some cases, user might want to disable Auto power off. There are two ways to disable this feature as following:

1. Power on the meter when any of the push functions, except for HOLD, is pressed down.
2. In addition, when RS232 output is active, the auto power off function is also disabled.

Note: Powering on the meter while pressing HOLD and lasts 2 seconds turns on all LCD segments until HOLD is pressed again.

1.10 Sleep

The meter enters sleep mode after auto power off. The SLEEP pin asserts low (-3V) in the sleep mode, and asserts high (+3V, not 0V) after re-power on.

1.11 Re-power on

After auto power-off, pushing any of the push function or changing the rotary mode can turn on the meter again. If the meter is re-powered on by changing the rotary mode, the saved state is cleared. If the meter is re-powered on by push functions, the chip restores the saved state and enters HOLD mode. The LCD displays the saved value.

1 Measurement Mode Switching

Measurement mode depends on the logic level of SLACDC, FC1, FC2, FC3, FC4, FC5, and KEY. When FC5 is high, the measurement mode list is below

SLACDC	FC1	FC2	FC3	FC4	Mode	Function of KEY
0	1	0	1	1	Voltage Measurement	DCV ↔ ACV
0	1	1	0	1	Auto DC Current Measurement(μA)	DCA ↔ ACA
0	1	1	1	1	Auto DC Current Measurement(mA)	DCA ↔ ACA
0	0	0	0	0	11A DC Current Measurement(A)	DCA ↔ ACA
0	1	1	1	0	Manual DC 1.1000A	DCA ↔ ACA
0	1	1	0	0	Manual DC 11.000A	DCA ↔ ACA
0	1	0	0	0	Manual DC 110.00A	DCA ↔ ACA
0	1	0	1	0	Manual DC 1100.0A	DCA ↔ ACA
0	1	0	0	1	Manual DC 11000A	DCA ↔ ACA
0	0	0	1	1	Resistance Measurement	Ω ↔ Continuity
0	0	0	0	1	Continuity Check	Continuity ↔ Diode
0	0	1	1	1	Resistance Measurement	Ω ↔ Continuity ↔ Diode
0	0	0	1	0	Frequency Measurement	—
0	0	1	1	0	Capacitance Measurement	—
0	0	1	0	0	Temperature Measurement	°C ↔ °F
1	1	0	1	1	Voltage Measurement	ACV ↔ DCV
1	1	1	0	1	Auto AC Current Measurement(μA)	ACμA ↔ DCμA
1	1	1	1	1	Auto AC Current Measurement(mA)	ACmA ↔ DCmA
1	0	0	0	0	11A AC Current Measurement(A)	ACA ↔ DCA
1	1	1	1	0	Manual AC 1.1000A	ACA ↔ DCA
1	1	1	0	0	Manual AC 11.000A	ACA ↔ DCA
1	1	0	0	0	Manual AC 110.00A	ACA ↔ DCA
1	1	0	1	0	Manual AC 1100.0A	ACA ↔ DCA
1	1	0	0	1	Manual AC 11000A	ACA ↔ DCA
1	0	0	1	1	*ADP0	—
1	0	0	0	1	*ADP1	—
1	0	1	1	1	*ADP2	—
1	0	0	1	0	*ADP3	—
1	0	1	1	0	*ADP4	—
1	0	1	0	0	Temperature Measurement	°F ↔ °C
X	0	1	0	1	Resistance Measurement	Ω ↔ Diode

X means “don’t care”.

*When FC5 is high, the ADP0, ADP1, ADP2, ADP3 and ADP4 modes can display minus sign.

Note1: The Manual DC/AC 1.1A, 11A, 110A, 1100A and 11000A modes are designed for clampmeter.

Note2: The 11A DC And 11A AC Current Measurement modes, (FC1~4) = (0, 0, 0, 0), are designed for multimeter.

When FC5=low, KEY is disabled and the measurement mode list is below.

SLACDC	FC1	FC2	FC3	FC4	Mode
0	1	0	1	1	DC Voltage Measurement
0	1	1	0	1	Auto DC Current Measurement(μ A)
0	1	1	1	1	Auto DC Current Measurement(mA)
0	0	0	0	0	11A DC Current Measurement(A)
0	1	1	1	0	Manual DC 1.1000A
0	1	1	0	0	Manual DC 11.000A
0	1	0	0	0	Manual DC 110.00A
0	1	0	1	0	Manual DC 1100.0A
0	1	0	0	1	Manual DC 11000A
0	0	0	1	1	Resistance Measurement
0	0	0	0	1	Continuity Check
0	0	1	1	1	Diode Measurement
0	0	0	1	0	Frequency Measurement
0	0	1	1	0	Capacitance Measurement
0	0	1	0	0	Temperature Measurement ($^{\circ}$ C)
1	1	0	1	1	AC Voltage Measurement
1	1	1	0	1	Auto AC Current Measurement(μ A)
1	1	1	1	1	Auto AC Current Measurement(mA)
1	0	0	0	0	11A AC Current Measurement(A)
1	1	1	1	0	Manual AC 1.1000A
1	1	1	0	0	Manual AC 11.000A
1	1	0	0	0	Manual AC 110.00A
1	1	0	1	0	Manual AC 1100.0A
1	1	0	0	1	Manual AC 11000A
1	0	0	1	1	*ADP0
1	0	0	0	1	*ADP1
1	0	1	1	1	*ADP2
1	0	0	1	0	*ADP3
1	0	1	1	0	*ADP4
1	0	1	0	0	Temperature Measurement ($^{\circ}$ F)
X	0	1	0	1	Resistance Measurement

X means "don't care".

*When FC5 is low, the ADP0, ADP1, ADP2, ADP3 and ADP4 modes can not display minus sign.

Note1: The Manual DC1.1A/11A/110A/1100A/11000A modes are designed for clampmeter.

Note2: The 11A DC Current Measurement mode, (FC1~4) = (0, 0, 0, 0), is designed for multimeter.

2 Push function

All the enabled push functions will be reset when the measurement mode is changed by rotary switch. Change measurement mode by KEY function will reset enabled Range, Hold, Max/Min, REL and Zero functions. The following table lists the available function versus measurement mode.

Function Mode	Range	Hold	Max/Min	REL	Zero	VAHz
Voltage	O	O	O	O	X	O
Current1	O	O	O	O	X	O
Current2	X	O	O	AC	DC	AC
Resistance	O	O	O	O	X	X
Capacitance	O	O	O	O	X	X
Frequency	O	O	O	O	X	X
Continuity	X	O	O	O	X	X
Diode	X	O	O	O	X	X
Temperature	X	O	O	O	X	X
ADP	X	O	O	O	X	X

Note:

Current1 includes Auto μ A, Auto mA and 11A modes.

Current2 includes Manual 1.1A, 11A, 110A, 1100A and 11000A modes.

2.1 HOLD

HOLD mode makes the meter stop updating the LCD panel. This mode can be nested in most of the special modes. Enabling HOLD function in automatic mode makes the meter switch to manual mode, but the full-scale range remains the same. HOLD function can be cancelled by changing the measurement mode, pressing RANGE, or push HOLD again.

2.2 Range

RANGE pin switches to and from automatic and manual mode, and while in manual mode, changes the full-scale range. The following figure shows the state transition.

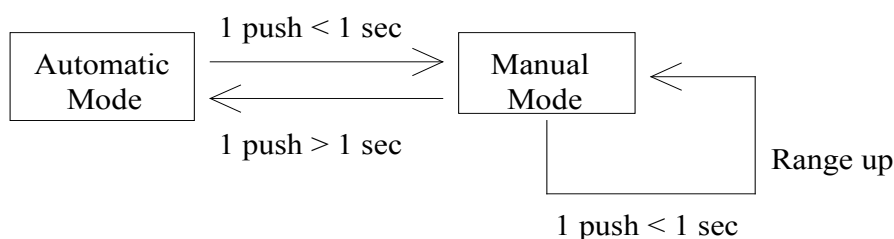

Measurement Mode	Auto	Manual	Control Range	Initial Range
V(DC/AC)	VR2 – VR5	VRi → VRi + 1, VR5 → VR1	110.00mV – 1100.0V	1.1000V
Auto μA(DC/AC)	R1 – R2	R1 → R2, R2 → R1	110.00μA – 1100.0μA	110.00μA
Auto mA(AC/DC)	R1 – R2	R1 → R2 R2 → R1	11.000mA – 110.00mA	11.000mA
11 A(DC/AC)	fixed	fixed	11.000A	11.000A
Ω	OR1 - OR7	ORi → ORi + 1, OR7 → OR1	110.00Ω – 110.0MΩ	110.00Ω
Capacitance	C1 – C8	Ci → Ci + 1, C8 → C1	11.000nF – 110.00mF	11.000nF
Continuity	fixed	fixed	110.00Ω	110.00Ω
Diode	fixed	fixed	1.1000V	1.1000V
Frequency	FR1 – FR6	FRi → FRi + 1 FR6 → FR1	1111Hz – 110.00MHz	1111Hz

Note: Pushing RANGE resets all existing special modes.

2.3 KEY

See Section “Measurement Mode Switching” for the function of this pin.

2.4 REL + HOLD

In REL mode, the LCD panel displays $D_{N+K} - D_N$, where $D_N = 1, 2, 3, \dots$, D_N is the last value before REL is pushed, and D_{N+K} is the current value. If REL is pushed again in REL mode, the meter displays the reference value. The meter returns to normal operation if REL is pressed and held for longer than one second. Pressing HOLD in REL mode makes the meter stop updating the LCD panel.

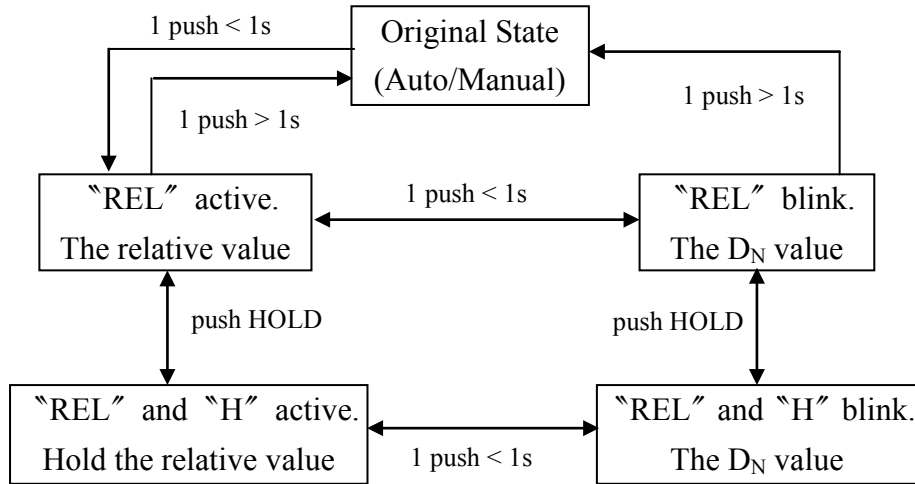

Note: It's possible that the relative value exceeds 11,000 or -11,000 counts, but never exceeds 19,999 or -19,999 counts. Such relative values are displayed. The LCD shows OL in REL mode only if D_N or D_{N+K} is more than 10,999 counts or the relative value is more than 19,999.

2.5 Max/Min + HOLD

The meter displays the maximum or minimum value of the input in Max/Min mode. When Max/Min is pressed for the first time, the meter displays the maximum value. When Max/Min is pressed again, the meter displays the minimum value. When Max/Min is pressed for the third time, the meter displays current value. The meter returns to normal operation if Max/Min is pressed and held for longer than one second. Pressing HOLD in Max/Min mode makes the meter stop updating the maximum or the minimum value.

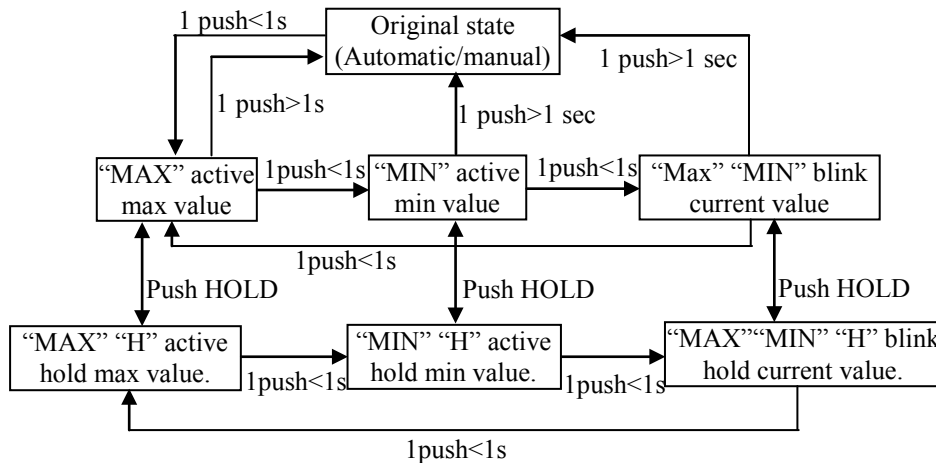

2.6 Relative + Max/Min + HOLD

Max/Min mode can be nested in REL mode. The meter displays the maximum or minimum value relative to the reference when Max/Min is pressed in REL mode. Pressing HOLD under REL + Max/Min makes the meter stop updating the LCD panel.

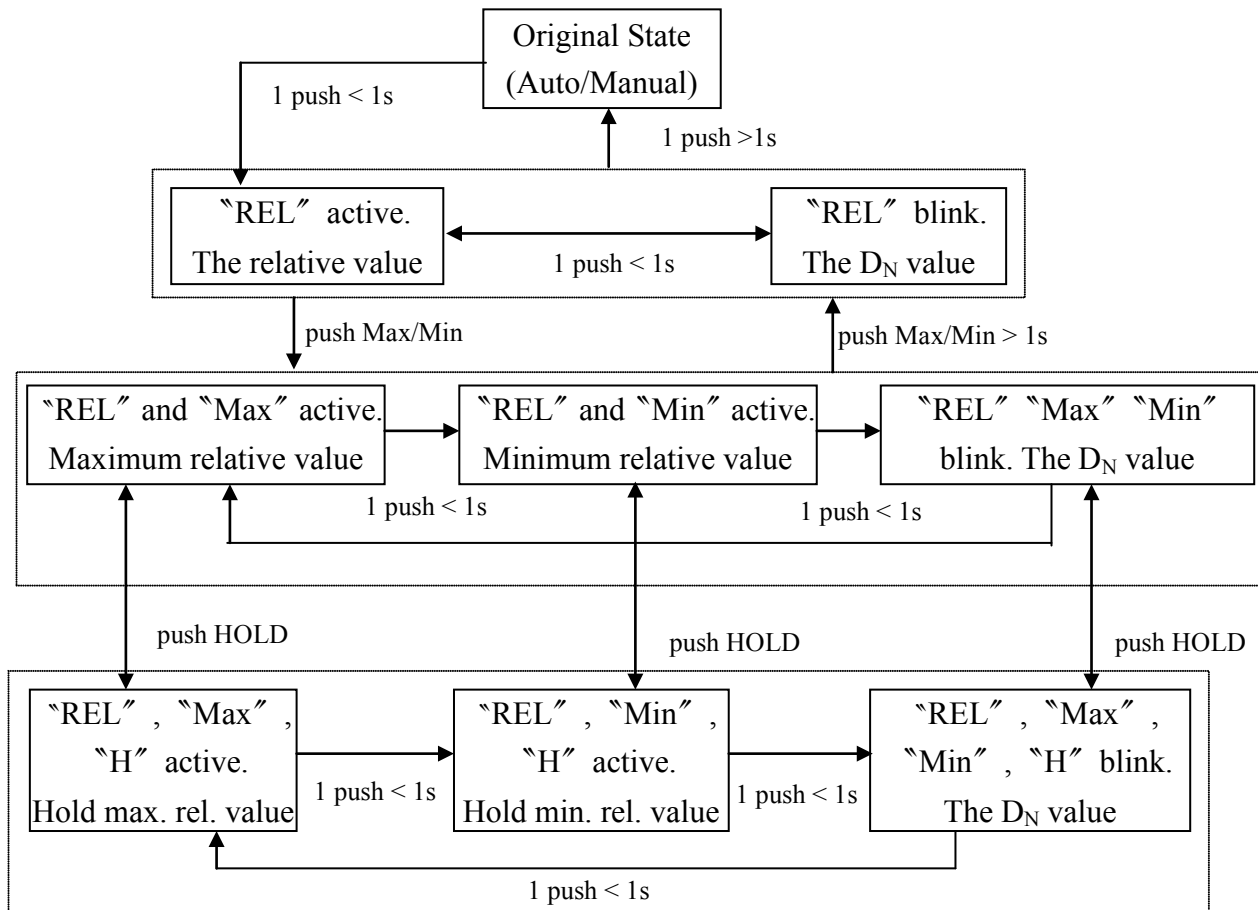

2.7 Zero : In manual DC 1.1000A, 11.000A, 110.00A, 1100.0A and 11000A

measurement modes, the REL_ZERO pin changes to control Zero function instead of relative function. In Zero mode, the LCD panel displays $D_{N+K} - D_N$, where $D_N = 1, 2, 3, \dots$, D_N is the last conversion value before Zero is pushed, and D_{N+K} is the current conversion value. If Zero is pushed again in Zero mode, the meter will refresh the D_N value and displays the $D_{N+K} - D_N$ again. The meter returns to normal operation if Zero is pressed and held for longer than one second. Pressing HOLD in Zero mode makes the meter stop updating the LCD panel. In Zero mode, LCD **will not** show any symbol to remind users of Zero mode is active.

State diagram for Zero mode:

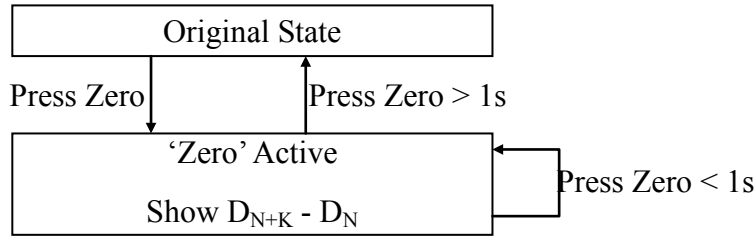

State diagram for Zero + HOLD mode:

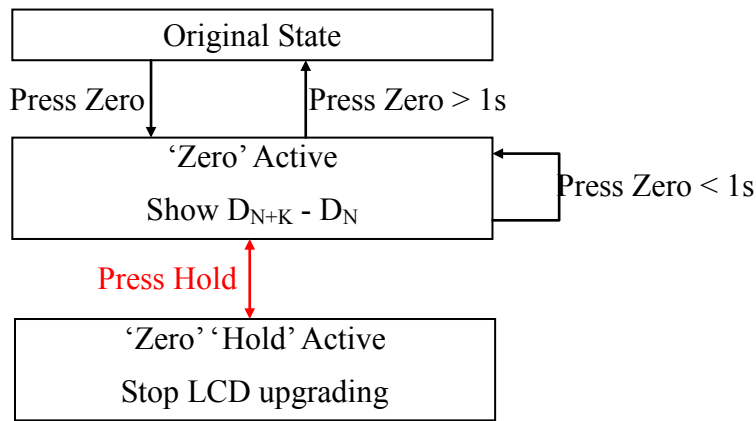

State diagram for Zero + Max/Min + HOLD mode:

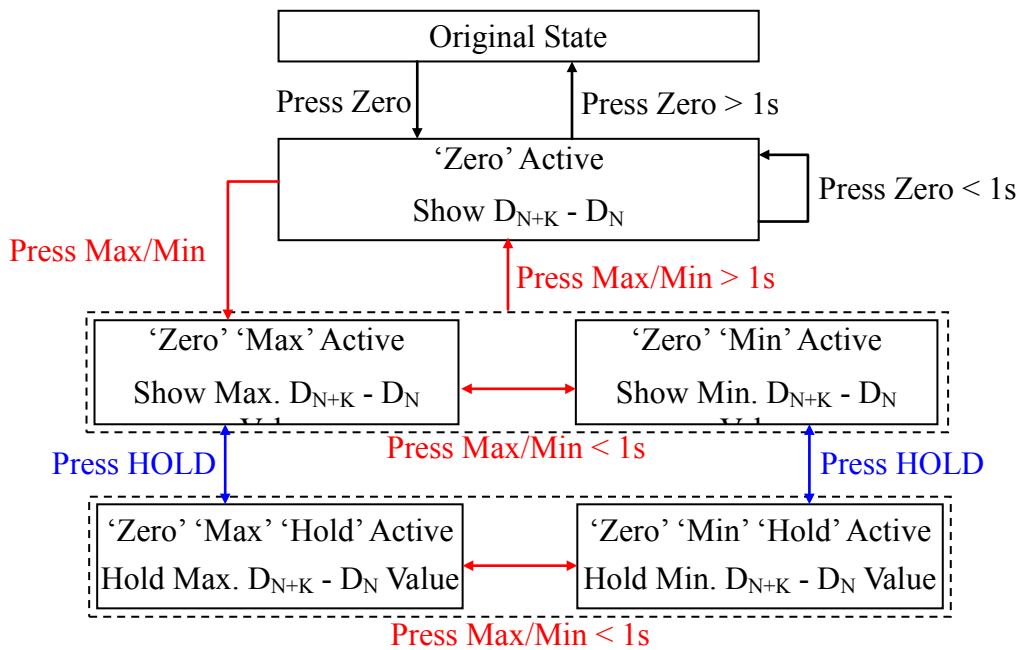

3.1 FUNCTUON

This packet indicates the measurement mode of the meter. The following table summarizes the transmitted code for each mode. Note that the encoding of this packet is different from the encoding of FC1-FC5 switch.

Code	Measurement Mode
0111011	Voltage
0111101	Auto μ A Current
0111111	Auto mA Current
0110000	11 A current
0111001	Manual A Current
0110011	Ω
0110101	Continuity
0110001	Diode
0110010	Frequency
0110110	Capacitance
0110100	*Temperature
0111110	ADP

*The judge bit in the Status packet determines whether the unit is Celsius or Fahrenheit.

3.2 RANGE

This packet indicates the full-scale range of the meter. When the meter operates in continuity mode or diode mode, this packet is always 0110000 since the full-scale ranges in these modes are fixed. The following table lists the code for each range in each measurement mode.

Code	V	Auto mA	Auto μ A	11 A	Manual A	ADP	Ω	Frequency	Capacitor
0110000	1.1000V	11.000mA	110.00 μ A		1.1000A	ADP4	110.00 Ω	1111Hz	11.000nF
0110001	11.000V	110.00mA	1100.0 μ A	11.000 A	11.000A	ADP3	1.1000K Ω	-	110.00nF
0110010	110.00V				110.00A	ADP2	11.000K Ω	11.000KHz	1.1000 μ F
0110011	1100.0V				1100.0A	ADP1	110.00K Ω	110.00KHz	11.000 μ F
0110100	110.00mV				11000A	ADP0	1.1000M Ω	1.1000MHz	110.00 μ F
0110101							11.000M Ω	11.000MHz	1.1000mF
0110110							110.0M Ω	110.00MHz	11.000mF
0110111									110.00mF

3.3 DIGIT 3 – DIGIT 0

Digit 3 is the second significant digit on the LCD panel, and digit 0 is the least significant digit.

Digit	Code
0	0110000
1	0110001
2	0110010
3	0110011
4	0110100
5	0110101
6	0110110
7	0110111
8	0111000
9	0111001

Note:

1. The RS232 code of digit4 is in the packet OPTION1
2. Because the cycle time of measurement for continuity/diode mode is only 50ms, the least significant digit may not be accurate

3.4 STATUS

The format of this package shown below. The Judge field is meaningful only when the Function packet indicates Temperature mode. In Temperature mode, judge is 1 if the unit is °F and is 0 if the unit is °C. Sign field indicates whether the minus sign on the LCD panel is on or off. BATT field is one when battery low condition is true. OL indicates input overflow.

0	1	1	Judge	Sign	BATT	OL
BIT 6	BIT 5	BIT 4	BIT 3	BIT 2	BIT 1	BIT 0

3.5 OPTION 1

0	1	1	UL			Digit4
BIT 6	BIT 5	BIT 4	BIT 3	BIT 2	BIT 1	BIT 0

UL field will be 1, only when input frequency is less than 11.1Hz in FR1 range of frequency mode.

The digit4 field will be 1, when the MSD on the LCD is one.

3.6 OPTION 2

This packet contains information on the operation mode of the meter. The format is shown below. The DC field indicates that the meter operates in DC measurement mode, either voltage or current. The AC field indicates that the meter operates in AC measurement mode, either voltage or current. The AUTO field is set to one if the meter operates in automatic mode, and is set to zero when the meter operates in manual mode.

0	1	1	DC	AC	AUTO	VAHZ
BIT 6	BIT 5	BIT 4	BIT 3	BIT 2	BIT 1	BIT 0

3.7 CR

Carrage return. The transmitted code is 0001101.

3.8 LF

Line feed. The transmitted code is 0001010.

4 Miscellaneous

The conditions on which the meter turns on the buzzer include:

- (1) Changing measurement mode generates one beep.
- (2) Pressing any of the push functions generates one beep, if the function is valid.
- (3) Power on and re-power on generate one beep.
- (4) Input overflow in voltage and current mode generates one beep every 0.3 seconds (or 3.33 beeps per second.)
- (5) Continuity(diode) check generates a continuous 2KHz beep whenever the measurement is less then $30\Omega(30mV)$
- (6) Auto power off generates a 2KHz beep which lasts for 1.5 seconds.

The following figures show the output waveform from the BUZOUT pin.

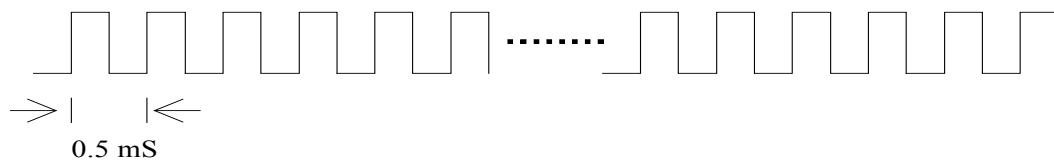

(a) Continuous 2KHz beep

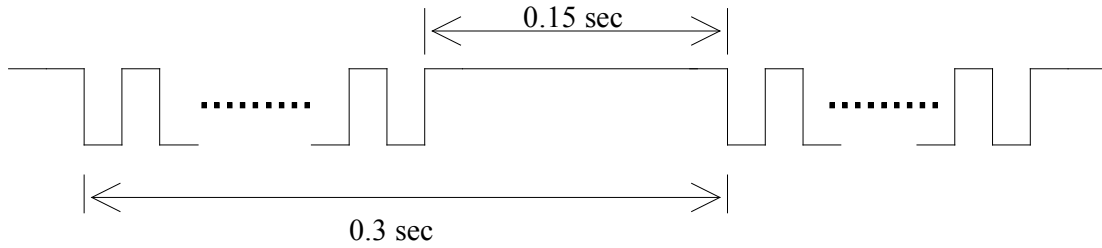

(b) 3.33 beep/sec

4.1 LCD Panel

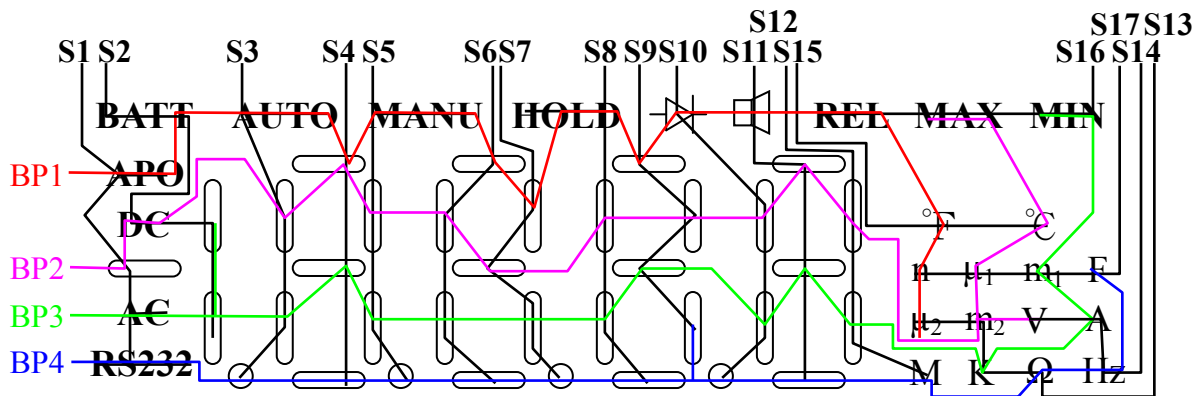

	SEG01	SEG02	SEG03	SEG04	SEG05	SEG06	SEG07	SEG08	SEG09
BP1	APO	BATT	AUTO	⊗	MANU	A3	B3	HOLD	A2
BP2	-	DC	F4	A4	B4	F3	G3	F2	B2
BP3	AC	BC5	E4	G4	C4	E3	C3	E2	G2
BP4	RS232	⊗	DP4	D4	DP3	D3	DP2	D2	C2



	SEG10	SEG11	SEG12	SEG13	SEG14	SEG15	SEG16	SEG17
BP1	⊗	⊗	⊗	μ ₂	⊗	°F	REL	n
BP2	F1	A1	B1	m ₂	V	°C	MAX	μ ₁
BP3	E1	G1	C1	K	A	⊗	MIN	m ₁
BP4	DP1	D1	M	Ω	Hz	⊗	⊗	F

Note: The MSD on LCD panel will not shows Zero

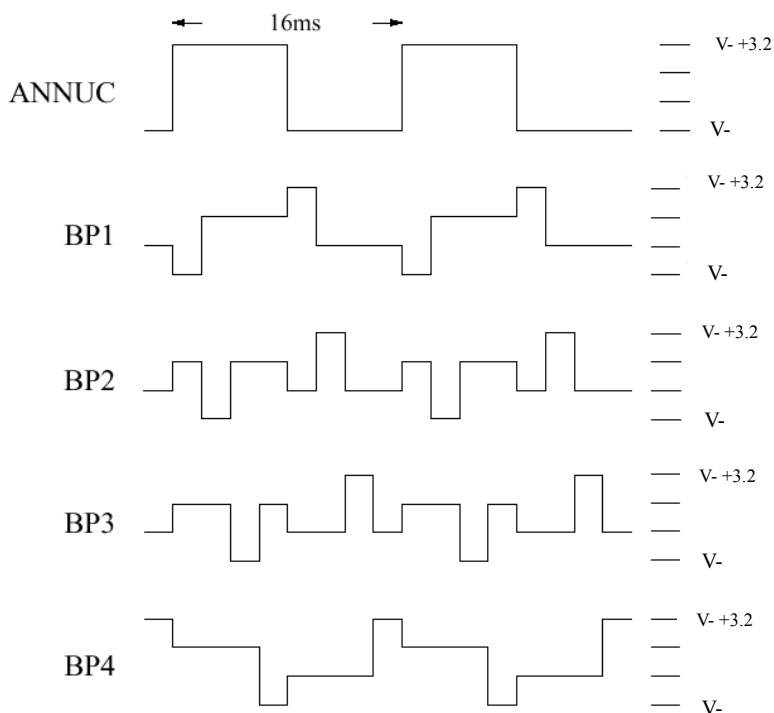
LCD Backplane Waveform



4.2 LCD display on condition

LCD Annunciator	Condition
V	In voltage measurement mode, and diode measurement mode.
A	In current measurement mode.
Ω	In resistance measurement mode, and continuity mode.
F	In capacitance measurement mode.
	In continuity check mode.
	In diode mode.
Hz	In frequency mode.
DC	In DC voltage or DC current mode.
AC	In AC voltage or AC current mode.
AUTO	When automatic full scale range selection is enabled.
MANU	In manual mode.
HOLD	When HOLD function is enabled.
REL	When Relative function is enabled.
MAX / MIN	When Maximum or Minimum function is enabled.
m ₁	In capacitor measurement mode and the full scale range is in the order of mF.
μ ₁	In capacitor measurement mode and the full scale range is in the order of μ F.
n	In capacitor measurement mode and the full scale range is in the order of nF.
m ₂	In voltage or current measurement mode and the full scale range is in the order of 10^{-3} .
μ ₂	In current measurement mode and the full scale range is in the order of μ A.
M	In resistance measurement mode and the full scale range is in the order of M Ω
K	In resistance measurement mode and the full scale range is in the order of K Ω
$^{\circ}$ C	In temperature measurement mode and when the unit is $^{\circ}$ C
$^{\circ}$ F	In temperature measurement mode and when the unit is $^{\circ}$ F
APO	When auto power off function is enabled.
RS232	When RS232 output is enabled.

4.3 Operating Timing

ES51911 incorporates a dual slope ADC with four phases: ZI, AZ, INT and DINT. The timing of each phase are listed below.

*Voltage /Current /ohm /ADP measurement:

Phase	Time
ZI	20ms
AZ	20ms
INT	100ms
DINT	110ms

P.S. In the DC voltage and ohm measurement with auto mode, if the range is changed, the internal clock rate will increase five times and the new measurement cycle becomes 1/5 times of the original cycle until the range is stable.

*Continuity/diode measurement

Phase	Time
ZI	4ms
AZ	4ms
INT	20ms
DINT	22ms

*Capacitance measurement:

Range	Total Measurement Time
11.000nF	0.25sec
110.00nF	0.25sec
1.1000uF	0.25sec
11.000uF	0.25sec
110.00uF	0.5sec
1.1000mF	1.0sec
11.000mF	2.5sec
110.00mF	12.5sec

*Frequency measurement

In range FR1, the measurement cycle = 0.5 sec

In range FR2~FR6, the measurement cycle = 1.05 sec

P.S. In the frequency measurement with auto mode, if the range is changed, the internal clock rate will increase ten times and the new measurement cycle becomes 1/10 times of the original cycle until the range is stable.

5 Test Circuit

1. Voltage test

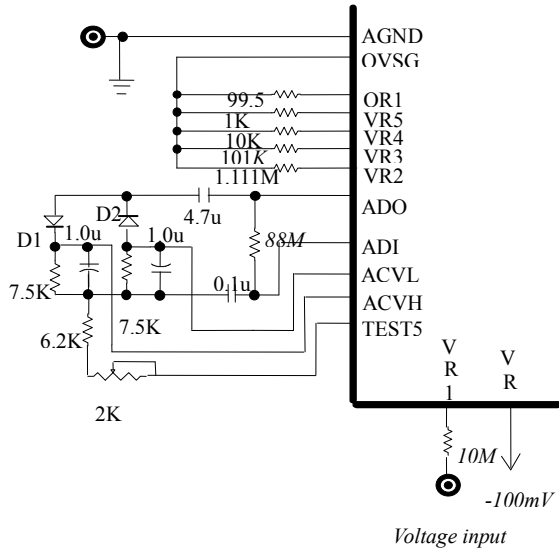

2. Resistor test

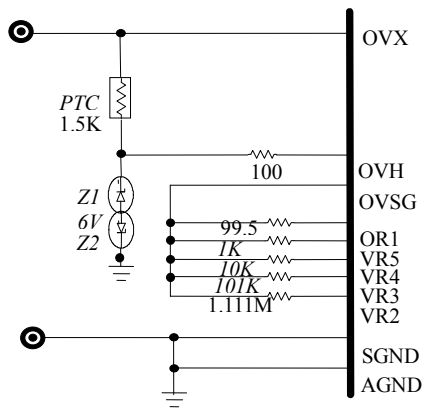

3. Current test for clamp meter

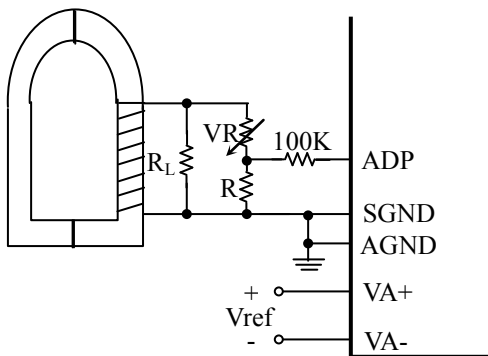

4. Current test

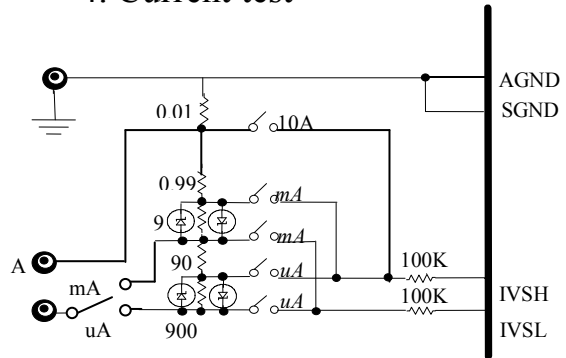

5. Diode test

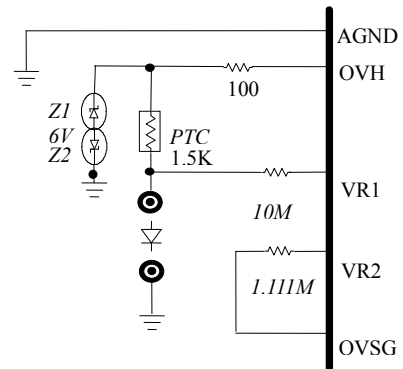

6. Low battery

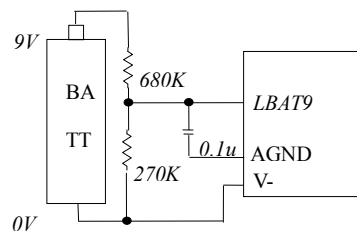

7. ADP test

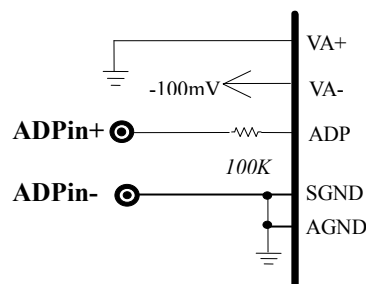

8. Frequency test

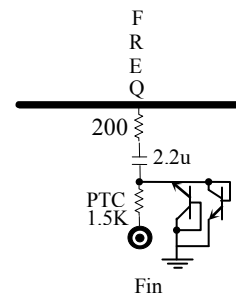



7. Application Circuit

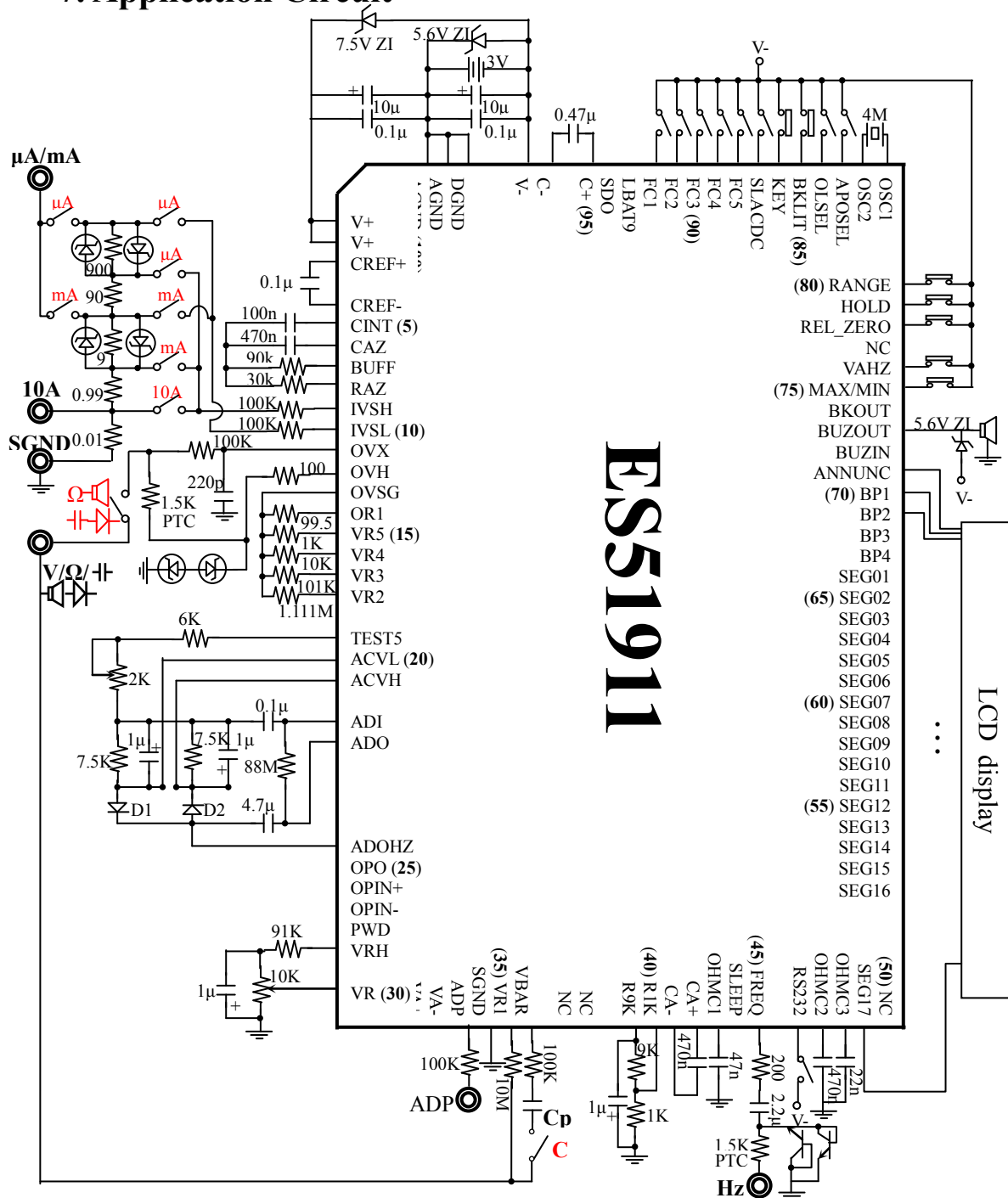

Notes:

1. Most of pins are protected by the ESD protection circuits. However pins, V+, V-, AGND, DGND and VR1 are not protected enough because the parasitic effect must be decrease. Therefore enough external protection is needed for assembling, carrying and keeping. In addition, components connecting to these unprotected pins have to be soldered on board before the IC is soldered.
2. Cp is the compensation capacitor for measuring capacitance. Its value depends on the parasitic capacitor on the PCB board.
3. Light shielding for the diodes and Zeners.
4. Zener diodes in above circuit are used for IC protection, so MUST be soldered on PCB first.

8. Package

1 100 Pin QFP Package

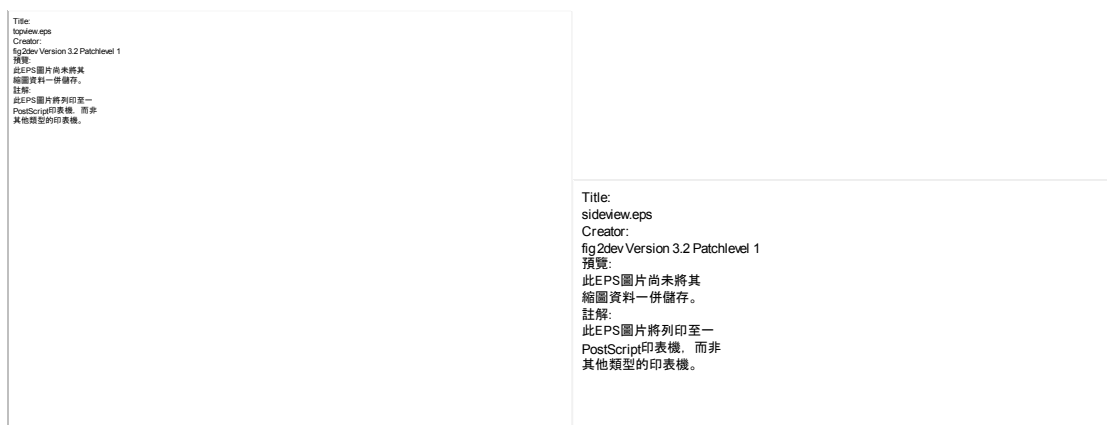

2 Dimension Paramenters

Symbol	Milimeter			Mill		
	Min.	Typ.	Max.	Min.	Typ.	Max.
W	19.90	20.00	20.10	783.5	787.4	791.3
L	13.90	14.00	14.10	547.2	551.2	551.2
A		0.425			16.7	
B	0.20	0.30	0.40	7.9	11.8	11.8
C		0.65			25.6	
d	1.05	1.20	1.35	41.3	47.2	47.2
a	2.57	2.72	2.87	101.2	107.1	107.1
D		2.50			98.4	
θ	0°		10°			