

DESCRIPTION

The EV2910ES-00A is an evaluation board for the MP2910ES that is a dual output with one synchronous buck PWM and one linear controller. The part is used to generate logic-supply voltages for PC based systems.

This EV board can be turned on or shut down via a remote EN input that is referenced to ground. This input is compatible with popular logic devices.

This EV board also has power good indicator to conform to Intel® new platform requirement on FSB_VTT power plane. The PG port is pulled to ground when the output voltage is under 10% of its setting voltage.

FEATURES

- 5V or 12V V_{CC} Supply Voltage
- Wide 5V to 20V Operating Input Range
- 10A Output Current
- Fixed 300KHz Frequency
- Internal Soft-Start
- Output Adjustable from 0.8V to $0.9 \times V_{IN}$

APPLICATIONS

- Graphic Card
- Motherboard, Desktop Servers
- IA Equipments
- Telecomm Equipments
- High Power DC-DC Regulators

ELECTRICAL SPECIFICATIONS

Parameter	Symbol	Value	Units
Input Voltage	V_{IN}	5 – 20	V
Output Voltage	V_{OUT}	3.3	V
Output Current	I_{OUT}	10	A

"MPS" and "The Future of Analog IC Technology" are Registered Trademarks of Monolithic Power Systems, Inc.

EV2910ES-00A EVALUATION BOARD

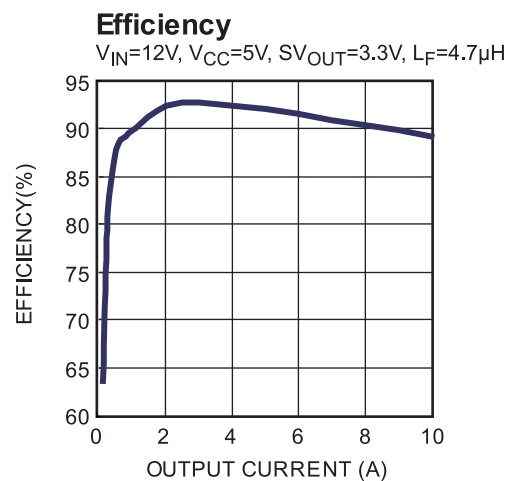

Board Number	MPS IC Number
EV2910ES-00A	MP2910ES

EVALUATION BOARD SCHEMATIC

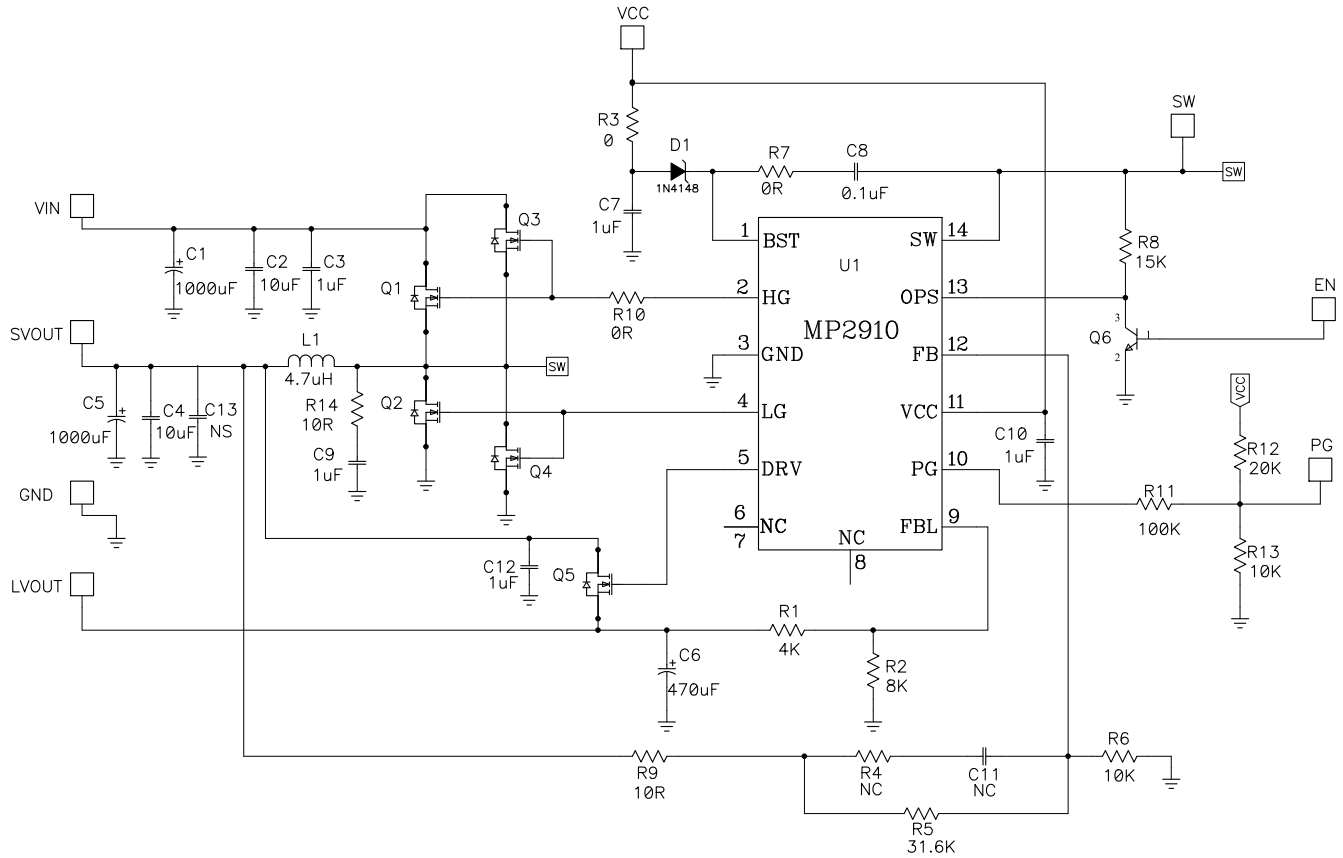

EV2910ES-00A BILL OF MATERIALS

Qty	Ref	Value	Description	Package	Manufacturer	Manufacturer P/N
2	C1, C5	1000 μ F	Electrolytic Cap. 25V	DIP	Rubycon	1000uF/25V
2	C2, C4	10 μ F	Ceramic Cap. 25V, X7R	1210	Murata	GRM32DR71E106KA12
1	C3	1 μ F	Ceramic Cap. 25V, X7R	1206	TDK	C3216X7R1E105K
1	C6	470 μ F	Electrolytic Cap. 16V	DIP	Rubycon	470 μ F
2	C7,C10	1 μ F	Ceramic Cap. 25V, X7R	0603	Murata	GRM188R71E105KA12
1	C8	0.1 μ F	Ceramic Cap. 50V, X7R	0603	Murata	GRM188R71H104KA93D
2	C9, C12	1 μ F	Ceramic Cap. 50V, X7R	0805	Murata	GRM21BR71H105KA12L
2	C11, C13	NS	Do Not Stuff	0603		
1	D1	0.5A, 40V	Schottky Diode	0603	Diodes Inc	B0540W
1	R1	4.02k Ω	Film Resistor ,1%	0603	Yageo	RC0603FR-074K02L
1	R2	8.06k Ω	Film Resistor, 1%	0603	Yageo	RC0603FR-078K06L
3	R3, R7, R10	0 Ω	Film Resistor ,5%	0603	Yageo	RC0603JR-070RL
1	R4	NS	Do Not Stuff	0603		
1	R5	31.6k Ω	Film Resistor ,1%	0603	Yageo	RC0603FR-0731K6L
2	R6, R13	10k Ω	Film Resistor, 1%	0603	Yageo	RC0603FR-0710KL
1	R8	15k Ω	Film Resistor, 1%	0603	Yageo	RC0603FR-0715KL
2	R9, R14	10 Ω	Film Resistor, 1%	0603	Yageo	RC0603FR-0710RL
1	R11	100k Ω	Film Resistor, 1%	0603	Yageo	RC0603FR-07100KL
1	R12	20k Ω	Film Resistor, 1%	0603	Yageo	RC0603FR-0720KL
1	Q3		AP4224, Rdson:20m Ω , Qg:23nC	SO-8	APEC	AP4224GM
2	Q2, Q5		AM4842N, Rdson:12m Ω ,Qg:25nC	SO-8	Analog Power	AM4842N
2	Q1, Q4	NC	Do Not Stuff	SO-8		
1	Q6	NC	Do Not Stuff	SOT-23		
1	L1	4.7 μ H	Inductor, DCR=7.7m Ω , Irms=15A	SMD	Wurth	7443551470
1	U1		Step-Down Regulator	SOP14	MPS	MP2910ES

PRINTED CIRCUIT BOARD LAYOUT

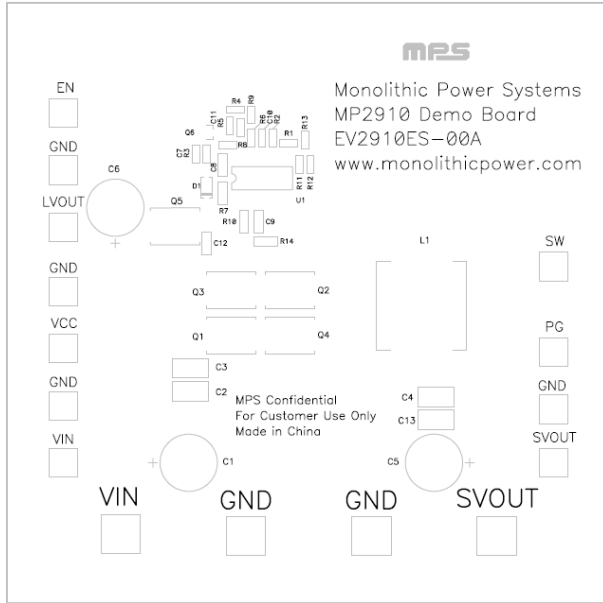

Figure 1—Top Silk Layer

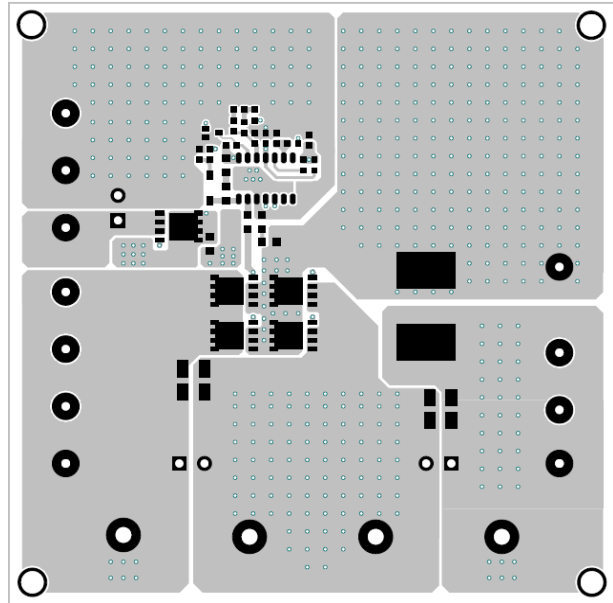

Figure 2—Top Layer

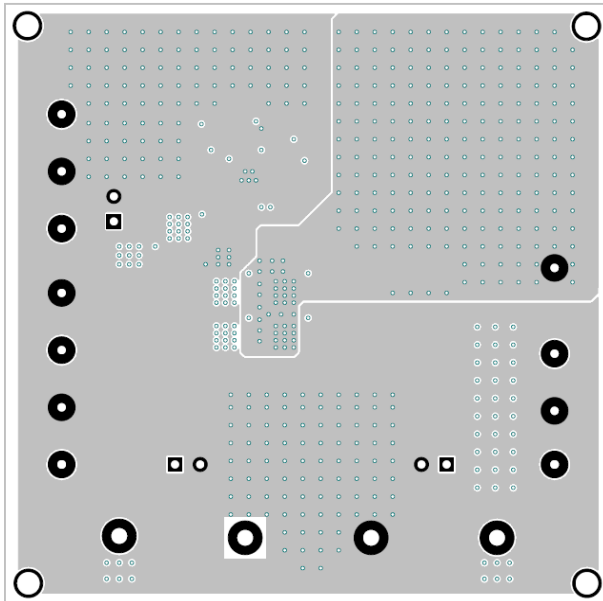

Figure 3—Inner Layer 1

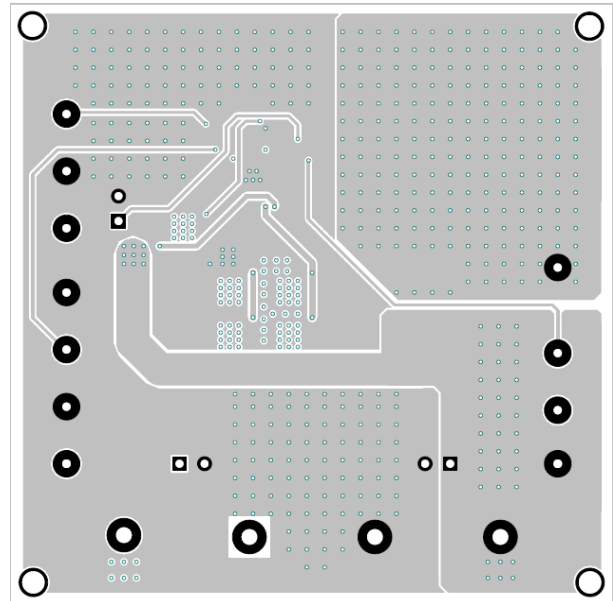

Figure 4—Inner Layer

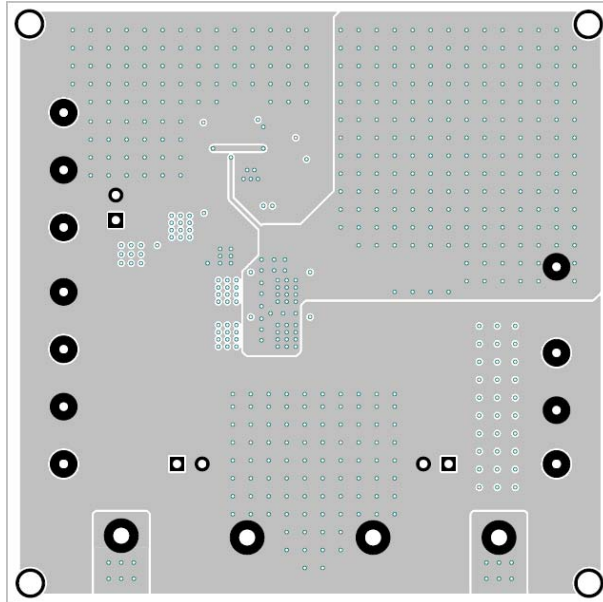

Figure 5—Bottom Layer

QUICK START GUIDE

1. Connect the positive and negative terminals of the load to the SV_{OUT} (or/and LV_{OUT}) and GND pins, respectively.
2. Preset a power supply 1# output between 5V and 20V, and another power supply 2# output 5V or 12V, then turn off them.
3. Connect the positive and negative terminals of the power supply 1# output to the VIN and GND pins, and connect the positive and negative terminals of the power supply 2# output to the VCC and GND pins, respectively.
4. To use the Enable function, add a mosfet or transistor for Q_6 , and then apply a digital input to the EN pin. Drive EN higher than 2V to turn off the controller or less than 0.4V to turn it on.
5. Turn the power supplies on. The MP2910 will automatically startup.
6. Use R5 and R6 to set the output voltage with $VFB = 0.8V$. Follow the Application Information section in the device datasheet to select the proper value of R5, R6, inductor and output capacitor values when output voltage is changed.

NOTICE: The information in this document is subject to change without notice. Users should warrant and guarantee that third party Intellectual Property rights are not infringed upon when integrating MPS products into any application. MPS will not assume any legal responsibility for any said applications.