

Surface Mount Transient Voltage Suppressors

TPSMBJ Series 11 To 170V 600W

Description

TVS diodes can be used in a wide range of applications which like consumer electronic products, automotive industries, munitions, telecommunications, aerospace industries, and intelligent control systems.

Working Voltage: 11 to 170 V

Peak Pulse Power: 600 W

Features

- ◆ Glass passivated chip
- ◆ 600 W peak pulse power capability with a 10/1000 μ s waveform, repetitive rate (duty cycle):0.01 %
- ◆ High reliability application and automotive grade AEC Q101 qualified
- ◆ Low leakage
- ◆ Uni and Bidirectional unit
- ◆ Excellent clamping capability
- ◆ Very fast response time
- ◆ RoHS compliant



Mechanical Data

- ◆ Case: Molded plastic
- ◆ Epoxy: UL 94V-0 rate flame retardant
- ◆ Lead: Solderable per MIL-STD-750, method 2026 guaranteed
- ◆ Polarity: Color band denotes cathode end except Bipolar
- ◆ Mounting position: Any

Applications

TVS devices are ideal for the protection of I/O interfaces, V_{CC} bus and other vulnerable circuits used in Telecom, Computer, Industrial and Consumer electronic applications.

Maximum Ratings and Thermal Characteristics ($T_A=25^\circ\text{C}$ unless otherwise noted)

Parameter	Symbol	Value	Units
Peak power dissipation with a 10/1000 μ s waveform ⁽¹⁾	P_{PPM}	600	W
Power Dissipation on Infinite Heat Sink at $T_L=75^\circ\text{C}$	P_D	5.0	W
Peak pulse current with a 10/1000 μ s waveform ⁽¹⁾	I_{PP}	See Next Table	A
Operating junction and storage temperature range	T_J, T_{STG}	-55 to +150	$^\circ\text{C}$
Maximum Instantaneous Forward Voltage at 50A for Unidirectional ⁽³⁾	V_F	3.5/5.0	V
Peak forward surge current, 8.3 ms single half sine-wave unidirectional only ⁽²⁾	I_{FSM}	100	A

Note:

(1)Non-repetitive current pulse per Fig.5 and derated above $T_A=25^\circ\text{C}$ per Fig.1

(2)Measured on 8.3 ms single half sine-wave or equivalent square wave, duty cycle = 4 pulses per minute maximum

(3) $V_F<3.5\text{V}$ for devices of $V_{BR}<200\text{V}$ and $V_F<5.0\text{V}$ for devices of $V_{BR}>201\text{V}$

Surface Mount Transient Voltage Suppressors

TPSMBJ Series 11 To 170V 600W

Electrical Characteristics (@ 25°C Unless Otherwise Specified)

Part Number		Marking		Reverse Stand-Off Voltage $V_{RWM}(V)$	Breakdown Voltage V_{BR} (V) @ I_T		Test Current I_T (mA)	Maximum Clamping Voltage V_C @ I_{PP} (V)	Maximum Peak Pulse Current I_{PP} (A)	Maximum Reverse Leakage I_R @ V_{RWM} (μA)
Uni	Bi	Uni	Bi		MIN	MAX				
TPSMBJ11A	TPSMBJ11CA	KZA	AZA	11.0	12.20	13.50	1	18.2	32.97	1
TPSMBJ12A	TPSMBJ12CA	LEA	BEA	12.0	13.30	14.70	1	19.9	30.15	1
TPSMBJ13A	TPSMBJ13CA	LGA	BGA	13.0	14.40	15.90	1	21.5	27.91	1
TPSMBJ14A	TPSMBJ14CA	LKA	BKA	14.0	15.60	17.20	1	23.2	25.86	1
TPSMBJ15A	TPSMBJ15CA	LMA	BMA	15.0	16.70	18.50	1	24.4	24.59	1
TPSMBJ16A	TPSMBJ16CA	LPA	BPA	16.0	17.80	19.70	1	26.0	23.08	1
TPSMBJ17A	TPSMBJ17CA	LRA	BRA	17.0	18.90	20.90	1	27.6	21.74	1
TPSMBJ18A	TPSMBJ18CA	LTA	BTA	18.0	20.00	22.10	1	29.2	20.55	1
TPSMBJ19A	TPSMBJ19CA	LBA	BBA	19.0	21.10	23.30	1	30.8	19.49	1
TPSMBJ20A	TPSMBJ20CA	LVA	BVA	20.0	22.20	24.50	1	32.4	18.52	1
TPSMBJ22A	TPSMBJ22CA	LXA	BXA	22.0	24.40	26.90	1	35.5	16.90	1
TPSMBJ24A	TPSMBJ24CA	LZA	BZA	24.0	26.70	29.50	1	38.9	15.42	1
TPSMBJ26A	TPSMBJ26CA	MEA	CEA	26.0	28.90	31.90	1	42.1	14.25	1
TPSMBJ28A	TPSMBJ28CA	MGA	CGA	28.0	31.10	34.40	1	45.4	13.22	1
TPSMBJ30A	TPSMBJ30CA	MKA	CKA	30.0	33.30	36.80	1	48.4	12.40	1
TPSMBJ33A	TPSMBJ33CA	MMA	CMA	33.0	36.70	40.60	1	53.3	11.26	1
TPSMBJ36A	TPSMBJ36CA	MPA	CPA	36.0	40.00	44.20	1	58.1	10.33	1
TPSMBJ40A	TPSMBJ40CA	MRA	CRA	40.0	44.40	49.10	1	64.5	9.30	1
TPSMBJ43A	TPSMBJ43CA	MTA	CTA	43.0	47.80	52.80	1	69.4	8.65	1
TPSMBJ45A	TPSMBJ45CA	MVA	CVA	45.0	50.00	55.30	1	72.7	8.25	1
TPSMBJ48A	TPSMBJ48CA	MXA	CXA	48.0	53.30	58.90	1	77.4	7.75	1
TPSMBJ51A	TPSMBJ51CA	MZA	CZA	51.0	56.70	62.70	1	82.4	7.28	1
TPSMBJ54A	TPSMBJ54CA	NEA	DEA	54.0	60.00	66.30	1	87.1	6.89	1
TPSMBJ58A	TPSMBJ58CA	NGA	DGA	58.0	64.40	71.20	1	93.6	6.41	1
TPSMBJ60A	TPSMBJ60CA	NKA	DKA	60.0	66.70	73.70	1	96.8	6.20	1
TPSMBJ64A	TPSMBJ64CA	NMA	DMA	64.0	71.10	78.60	1	103.0	5.83	1
TPSMBJ70A	TPSMBJ70CA	NPA	DPA	70.0	77.80	86.00	1	113.0	5.31	1
TPSMBJ75A	TPSMBJ75CA	NRA	DRA	75.0	83.30	92.10	1	121.0	4.96	1
TPSMBJ78A	TPSMBJ78CA	NTA	DTA	78.0	86.70	95.80	1	126.0	4.76	1
TPSMBJ85A	TPSMBJ85CA	NVA	DVA	85.0	94.40	104.00	1	137.0	4.38	1
TPSMBJ90A	TPSMBJ90CA	NXA	DXA	90.0	100.00	111.00	1	146.0	4.11	1
TPSMBJ100A	TPSMBJ100CA	NZA	DZA	100.0	110.00	123.00	1	162.0	3.70	1
TPSMBJ110A	TPSMBJ110CA	PEA	EEA	110.0	122.00	135.00	1	177.0	3.39	1
TPSMBJ120A	TPSMBJ120CA	PGA	EGA	120.0	133.00	147.00	1	193.0	3.11	1
TPSMBJ130A	TPSMBJ130CA	PKA	EKA	130.0	144.00	159.00	1	209.0	2.87	1
TPSMBJ140A	TPSMBJ140CA	PBA	EBA	140.0	155.00	171.00	1	226.8	2.65	1
TPSMBJ150A	TPSMBJ150CA	PMA	EMA	150.0	167.00	185.00	1	243.0	2.47	1
TPSMBJ160A	TPSMBJ160CA	PPA	EPA	160.0	178.00	197.00	1	259.0	2.32	1
TPSMBJ170A	TPSMBJ170CA	PRA	ERA	170.0	189.00	209.00	1	275.0	2.18	1

Note:

- (1) Add suffix 'C' or 'CA' after part number to specify Bi-directional devices
- (2) For Bi-Directional devices having VR of 10 volts and under, the IR limit is double

Surface Mount Transient Voltage Suppressors

TPSMBJ Series 11 To 170V 600W

Ratings and Characteristics Curves ($T_A = 25^\circ\text{C}$ unless otherwise noted)

Figure 1 - Pulse Waveform

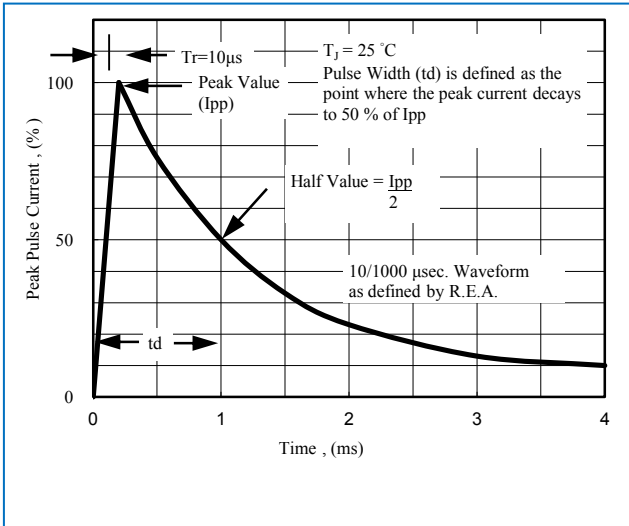

Figure 2 - Pulse Derating Curve

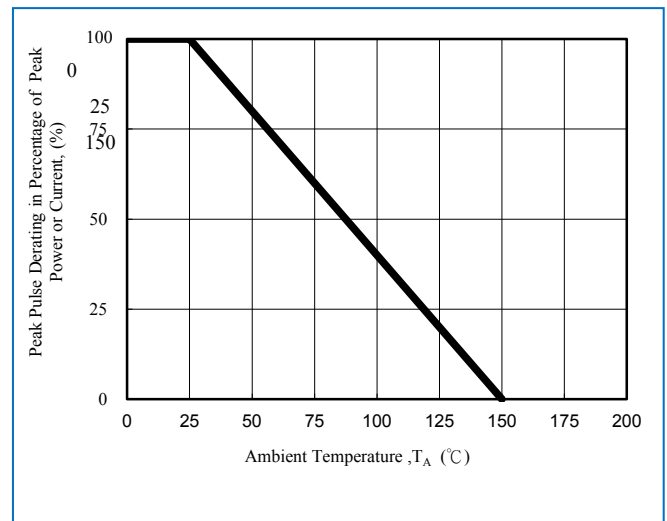

Figure 3 - Peak Pulse Power Rating Curve

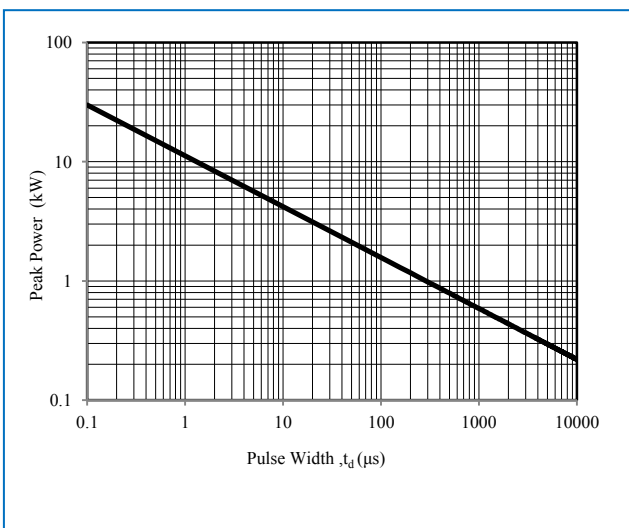
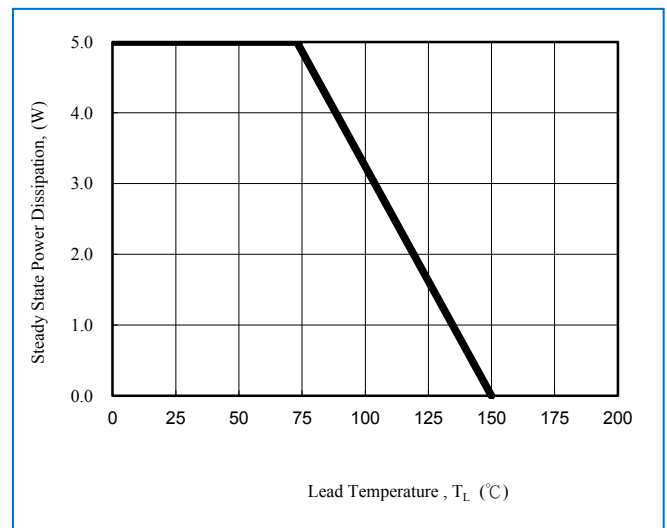

Figure 4 - Steady State Power Derating Curve



Surface Mount Transient Voltage Suppressors

TPSMBJ Series 11 To 170V 600W

Figure 5 - Maximum Non-Repetitive Surge Current

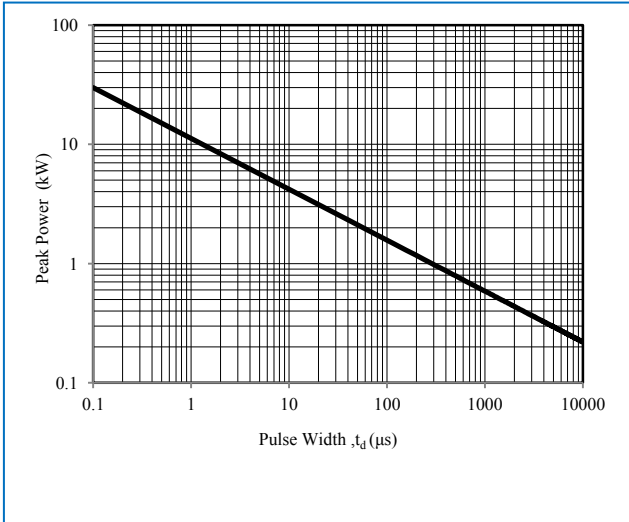
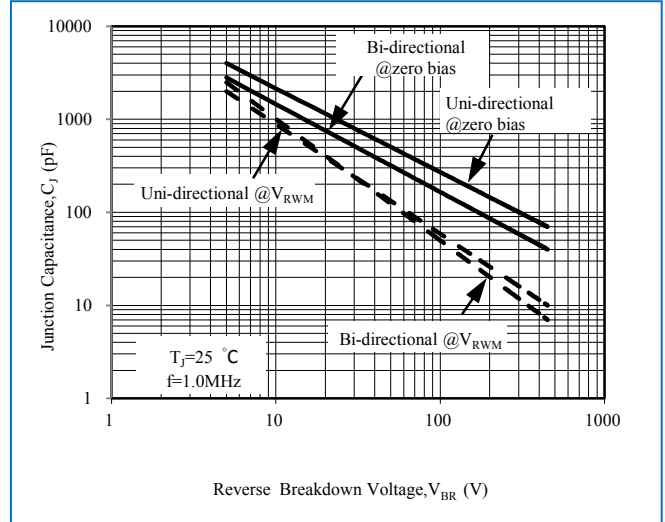
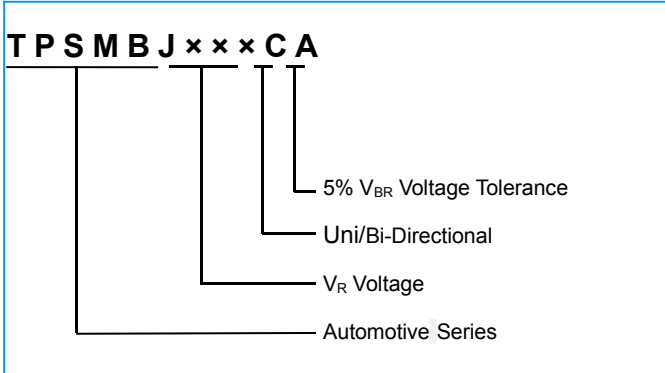

Figure 6 - Typical Junction Capacitance



Part Numbering



Surface Mount Transient Voltage Suppressors

TPSMBJ Series 11 To 170V 600W

Soldering Parameters

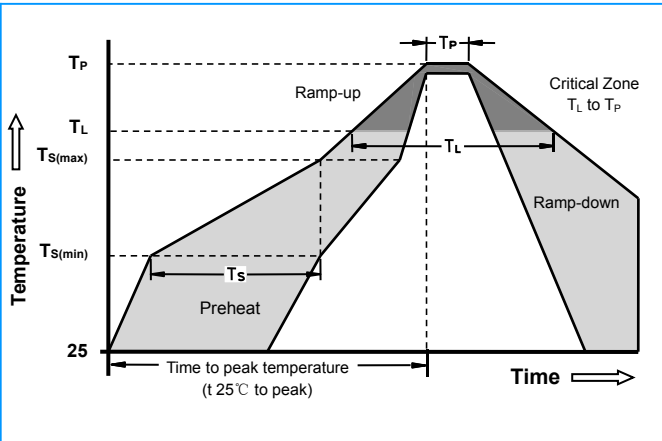

Reflow Condition		Lead-free assembly
Pre Heat	- Temperature Min ($T_{S(min)}$)	150°C
	- Temperature Max ($T_{S(max)}$)	200°C
	- Time (min to max) (t_s)	60 - 180 Seconds
Average ramp up rate (Liquidus Temp T_L) to peak		3°C/second max
$T_{S(max)}$ to T_L - Ramp-up Rate		3°C/second max
Reflow	- Temperature (T_L) (Liquidus)	217°C
	- Time (min to max) (t_s)	60 - 150 Seconds
Peak Temperature (T_P)		260 +0/-5°C
Time within 5°C of actual peak Temperature (t_p)		20 - 40 Seconds
Ramp-down Rate		6°C/second max
Time 25°C to peak Temperature (T_P)		8 minutes Max
Do not exceed		280°C

Dimensions

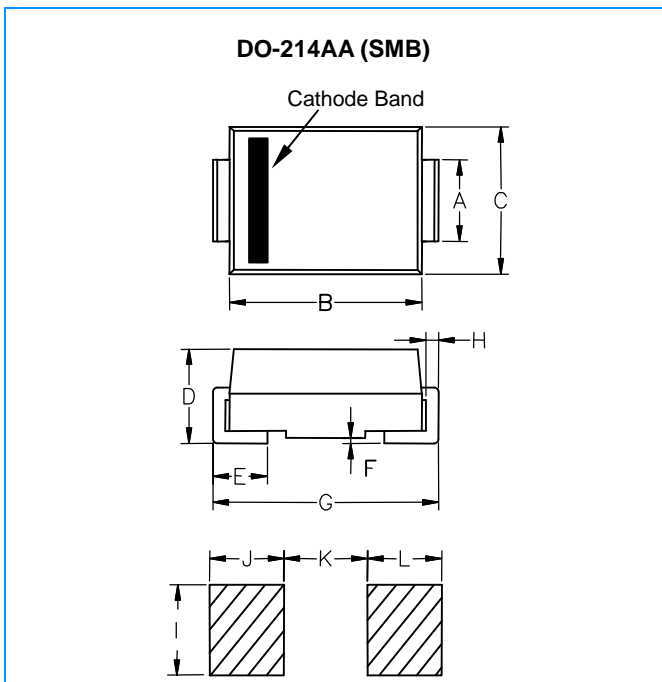

Dimensions	Inches		Millimeters	
	Min	Max	Min	Max
A	0.077	0.087	1.960	2.200
B	0.171	0.191	4.350	4.850
C	0.130	0.155	3.300	3.940
D	0.084	0.096	2.130	2.440
E	0.030	0.060	0.750	1.520
F	-	0.008	-	0.203
G	0.201	0.216	5.100	5.500
H	0.006	0.012	0.152	0.305
I	0.089	-	2.260	-
J	0.085	-	2.160	-
K	-	0.107	-	2.740
L	0.085	-	2.160	-