

Rev	AWO #	Description	Date	Appr
-	9754	RELEASED	9/18/09	

APPROVED: _____
 DATE: _____ TITLE: _____

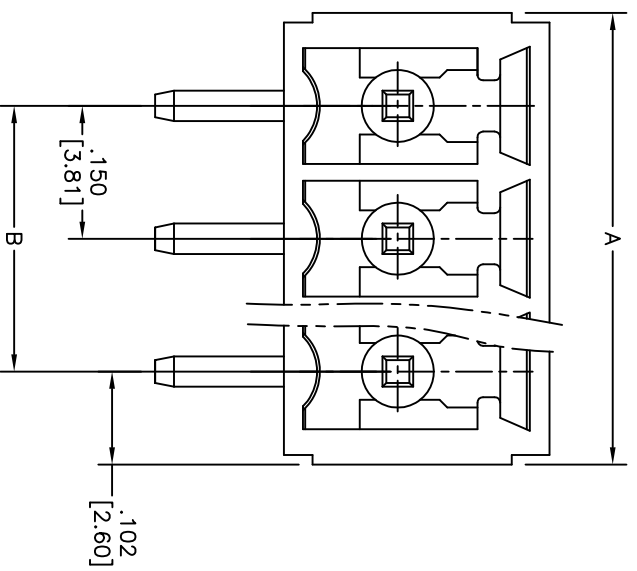
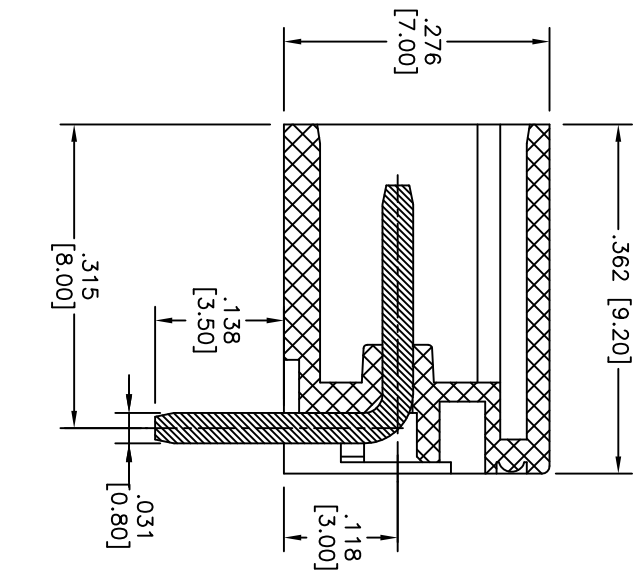

SPECIFICATIONS:
 Material: Insulator: Thermoplastic, rated UL 94V-0
 Insulator color: Black
 Wire Guard: Phosphor Bronze, Tin plated
 Terminal Body: Brass, Zinc plated
 Screw: Steel, Zinc plated

Electrical:
 Operation voltage: 300V
 Current rating: 8 Amps
 Insulation resistance: 500 Mohms min @ 500V
 Dielectric withstanding voltage: 2000 VAC for 1 minute
 Environmental:
 Lead free, RoHS compliant.
 Operating temperature: -40°C to +105°C



2 thru 24 Poles Available
 A = .150 [3.81] x No. of Poles + .055 [1.39]
 B = .150 [3.81] x No. of Spaces

UNLESS OTHERWISE SPECIFIED ALL DIMENSIONS ARE INCHES [MM]	
TOLERANCES: EXCEPT AS NOTED	
INCHES	HOLEES
.X ± .10	ØX ± .10
.XX ± .020	ØXX ± .015
.XXX ± .015	ØXXX ± .010
APPROVALS	DATE
DRAWN	DY
CHECKED	
APPROVED	

ADAM TECH
 909 Rahway Avenue, Union, NJ 07083
 Phone: 908-687-5000 Fax: 908-687-5710

TITLE: EURO BLOCK, RIGHT ANGLE HEADER,
 PITCH .150 [3.81], 2 THRU 24 POLES

SIZE	PART NO.	REV.
X	EBS-XX-B-BK	-
REF: S00260	SCALE: NTS	SHEET 1 OF 1