

Features

- Fast Switching Speed
- Surface Mount Package Ideally Suited for Automatic Insertion
- For General Purpose Switching Applications
- High Conductance

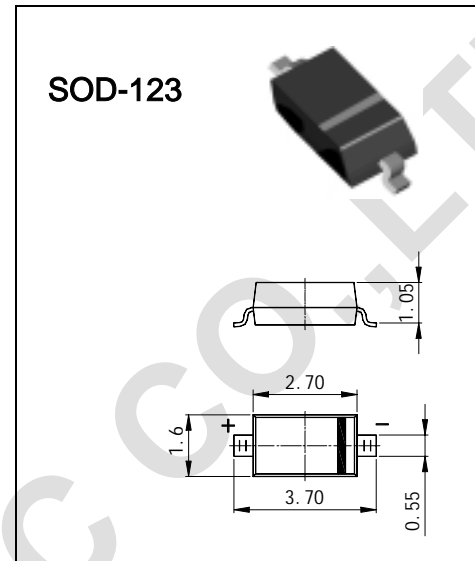

Maximum Ratings @ T_A = 25°C unless otherwise specified

Characteristic	Symbol	Value	Unit
Non-Repetitive Peak Reverse Voltage	V _{RM}	100	V
Peak Repetitive Reverse Voltage Working Peak Reverse Voltage DC Blocking Voltage	V _{R(RM)} V _{R(WM)} V _R	75	V
RMS Reverse Voltage	V _{R(RMS)}	53	V
Forward Continuous Current (Note 1)	I _{FM}	300	mA
Average Rectified Output Current (Note 1)	I _O	150	mA
Non-Repetitive Peak Forward Surge Current @ t = 1.0μs @ t = 1.0s	I _{FSM}	2.0 1.0	A
Power Dissipation (Note 1)	P _d	400	mW
Thermal Resistance Junction to Ambient Air (Note 1)	R _{θJA}	315	K/W
Operating and Storage Temperature Range	T _J , T _{STG}	-65 to +150	°C

Electrical Characteristics @ T_A = 25°C unless otherwise specified

Characteristic	Symbol	Min	Max	Unit	Test Condition
Maximum Forward Voltage	V _{FM}	—	0.715 0.855 1.0 1.25	V	I _F = 1.0mA I _F = 10mA I _F = 50mA I _F = 150mA
Maximum Peak Reverse Current	I _{RM}	—	1.0 50 30 25	μA μA μA nA	V _R = 75V V _R = 75V, T _J = 150°C V _R = 25V, T _J = 150°C V _R = 20V
Junction Capacitance	C _J	—	2.0	pF	V _R = 0, f = 1.0MHz
Reverse Recovery Time	t _{rr}	—	4.0	ns	I _F = I _R = 10mA, I _{rr} = 0.1 × I _R , R _L = 100Ω

Notes: 1. Valid provided that terminals are kept at ambient temperature.

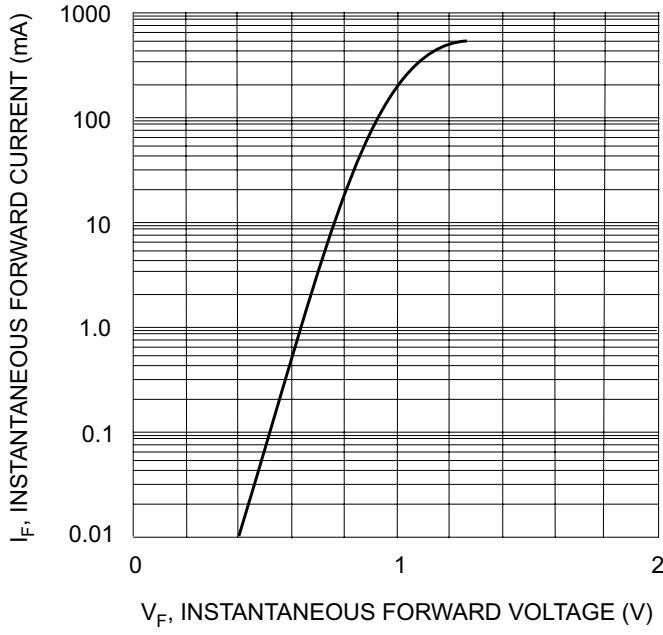

Fig. 1 Forward Characteristics

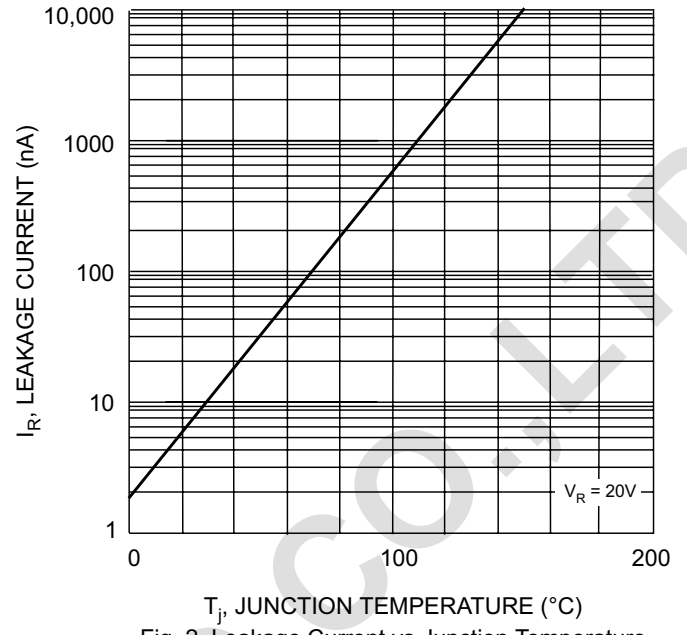
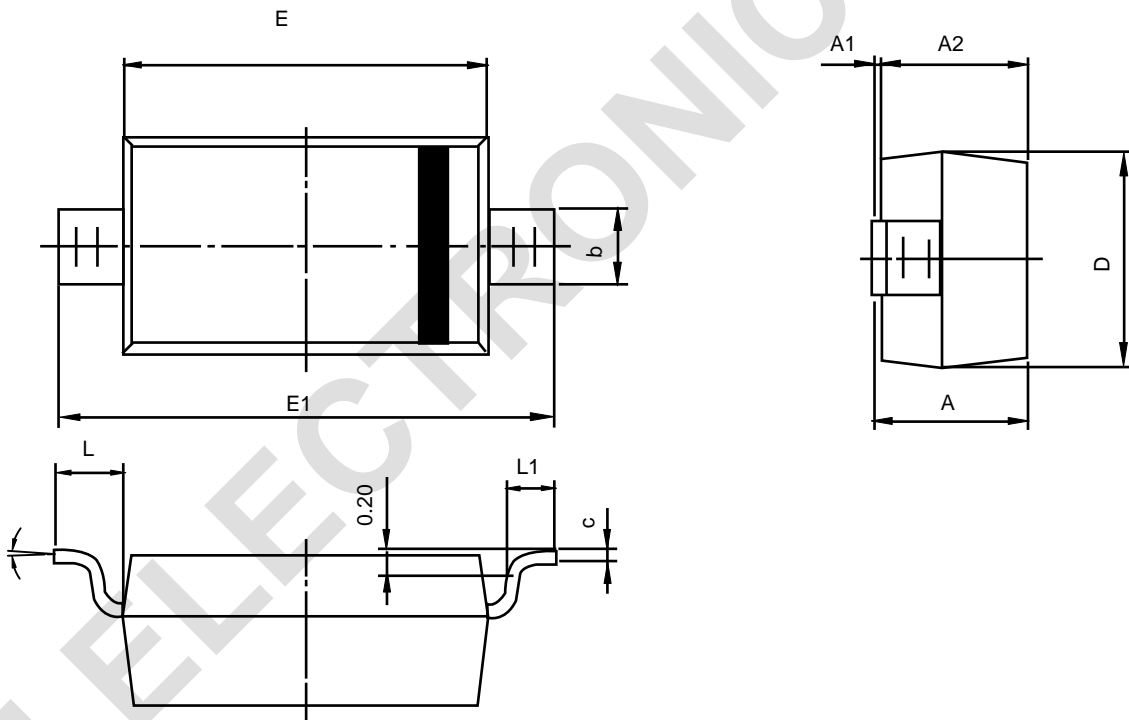

Fig. 2 Leakage Current vs Junction Temperature



Symbol	Dimensions In Millimeters		Dimensions In Inches	
	Min	Max	Min	Max
A	1.050	1.250	0.041	0.049
A1	0.000	0.100	0.000	0.004
A2	1.050	1.150	0.041	0.045
b	0.450	0.650	0.018	0.026
c	0.080	0.150	0.003	0.006
D	1.500	1.700	0.059	0.067
E	2.600	2.800	0.102	0.110
E1	3.550	3.850	0.140	0.152
L	0.500REF		0.020REF	
L1	0.250	0.450	0.010	0.018
θ	0°	8°	0°	8°