



Lead Free SMD Resettable Fuse

Document No	TRF10OS000A
Issued date	2009/01/10
Page	1/7

1. Scope

This specification applies for the Lead-Free SMD Resettable fuse series .

2. Construction

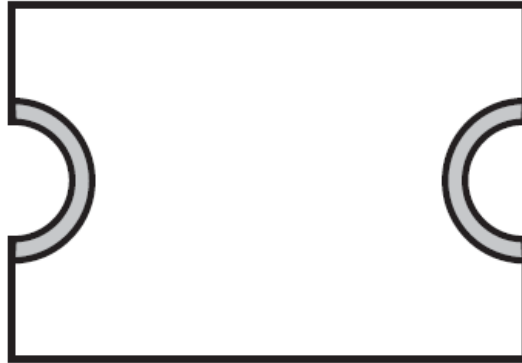

Terminal material:
Electroless Ni under immersion Au

Termination pad solderability:
Standard Au finish:
Meets ANSI/J-STD-002 Category 2.

3. Type Designation

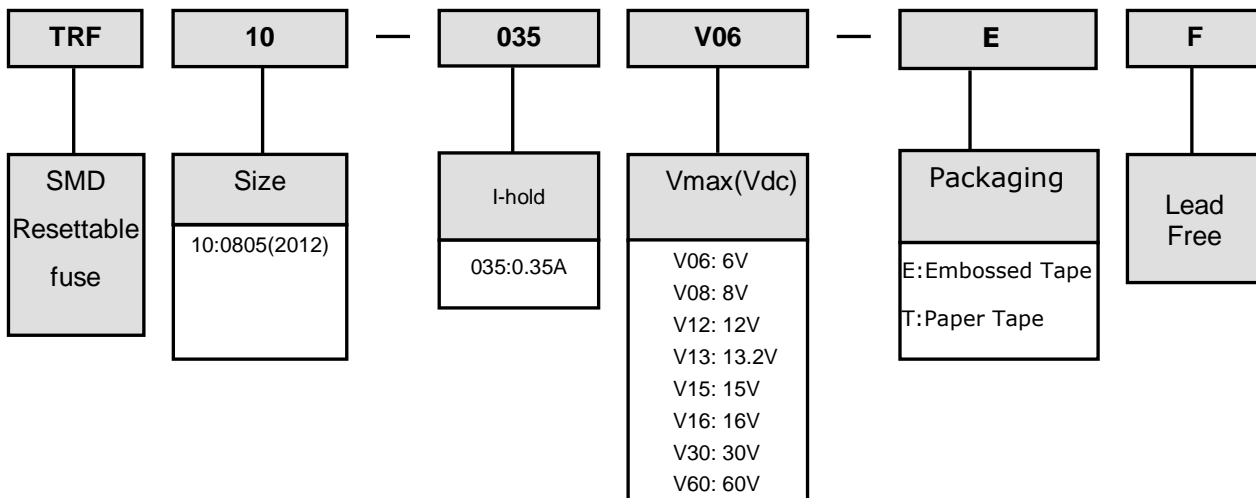



Lead Free SMD Resettable Fuse

Document No	TRF10OS000A
Issued date	2009/01/10
Page	2/7

4. Dimensions

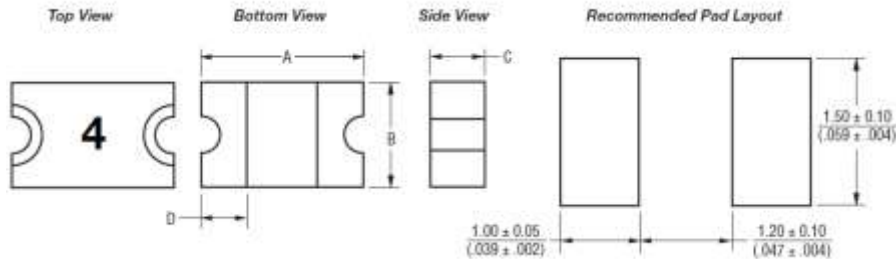

Dimensions

Unit: mm

Part Designation	A		B		C		D
	Min.	Max.	Min.	Max.	Min.	Max.	Min.
TRF10-010V15-EF	2.00	2.30	1.20	1.50	0.48	0.85	0.20
TRF10-020V09-EF	2.00	2.30	1.20	1.50	0.48	0.85	0.20
TRF10-035V06-EF	2.00	2.30	1.20	1.50	0.48	0.85	0.20
TRF10-050V06-EF	2.00	2.30	1.20	1.50	0.48	0.85	0.20
TRF10-075V06-EF	2.00	2.30	1.20	1.50	0.75	1.25	0.20
TRF10-110V06-EF	2.00	2.30	1.20	1.50	0.75	1.25	0.20

Packaging: 3000 pcs. per reel.

5. Applications and ratings

Part Designation	V_{max} (Vdc)	I_{max} (A)	I_{hold} at 23°C (A)	I_{trip} at 23°C (A)	P_d Typ. (W)	Maximum time to trip at 23°C		Resistance at 23°C	
						Current (A)	Time (Sec)	$R_{i_{min}}$ (Ω)	$R_{1_{max}}$ (Ω)
TRF10-010V15-EF	15	40	0.10	0.3	0.5	0.5	1.5	1	7.5
TRF10-020V09-EF	9	40	0.20	0.5	0.5	8	0.02	0.65	3.5
TRF10-035V06-EF	6	40	0.35	0.75	0.5	8	0.1	0.25	1.2
TRF10-050V06-EF	6	40	0.50	1	0.5	8	0.1	0.15	0.9
TRF10-075V06-EF	6	40	0.75	1.5	0.6	8	0.2	0.09	0.35
TRF10-110V06-EF	6	40	1.10	2.2	0.6	8	0.3	0.06	0.21

I_{hold} = Hold Current. Maximum current device will sustain for 30min without tripping in 23°C still air.

I_{trip} = Trip Current. Minimum current at which the device will trip in 23°C still air.

V_{max} = Maximum voltage device can withstand without damage at rated current.

I_{max} = Maximum fault current device can withstand without damage at rated voltage.

P_d = Power dissipated from device when in the tripped state at 23°C still air.

$R_{i_{min}}$ = Typical resistance of device in initial (un-soldered) state.

$R_{1_{max}}$ = Maximum resistance of device at 23°C measured one hour post reflow.

TA-I TECHNOLOGY CO., LTD

Specifications are subject to change without notice.
Customers should verify actual device performance in their specific applications.



Lead Free SMD Resettable Fuse

Document No	TRF10OS000A
Issued date	2009/01/10
Page	3/7

6. Thermal Derating Chart

Part	Maximum ambient operating temperature(T_{mao}) vs. hold current (I_{hold}) (Amps)								
	Designation	-40°C	-20°C	0°C	23°C	40°C	50°C	60°C	70°C
TRF10-010V15-EF	0.15	0.13	0.12	0.10	0.09	0.08	0.07	0.06	0.05
TRF10-020V09-EF	0.28	0.25	0.23	0.20	0.17	0.14	0.12	0.10	0.07
TRF10-035V06-EF	0.47	0.44	0.39	0.35	0.30	0.27	0.24	0.20	0.14
TRF10-050V06-EF	0.68	0.62	0.55	0.50	0.40	0.37	0.33	0.29	0.23
TRF10-075V06-EF	1.00	0.90	0.79	0.75	0.63	0.57	0.53	0.42	0.35
TRF10-110V06-EF	1.45	1.35	1.20	1.10	0.92	0.84	0.75	0.65	0.52

7. Typical Time to Trip at 23 °C

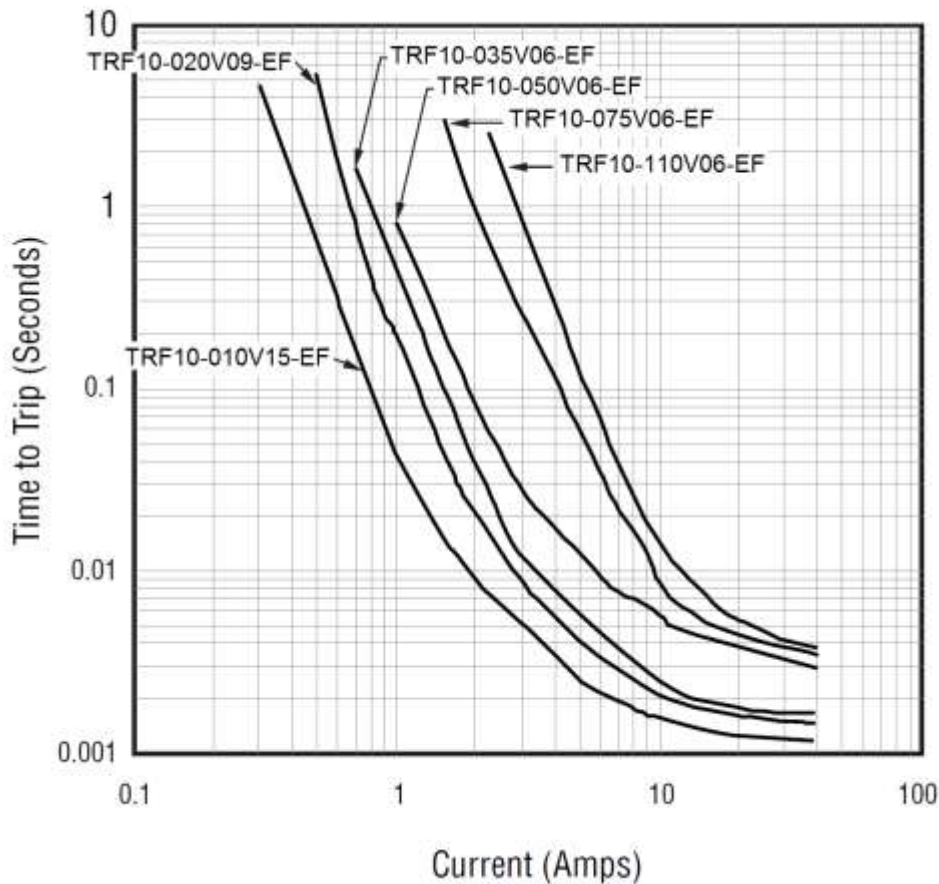

The Time to Trip curves represent typical performance of a device in a simulated application environment. Actual performance in specific customer applications may differ from these values due to the influence of other variables.



Lead Free SMD Resettable Fuse

Document No	TRF10OS000A
Issued date	2009/01/10
Page	4/7

8. Environment

8.1 Operating Conditions

Operating Temperature: -40°C to 85°C

Device Surface Temperature in Tripped State: 125°C max

8.2 Environmental Specifications

TEST ITEM	Condition	Resistance Change
Passive aging	85°C, 1000hr	±5% typical
Humidity aging	85°C, 85%R.H, 1000hr	±5% typical
Thermal shock	85°C to -40°C, 20times	±10% typical
Resistance to solvent	MIL-STD-202, Method 215	No change
Vibration	MIL-STD-883C, Method 2007.1 Condition A	No change

8.3 Solder Reflow Recommendations

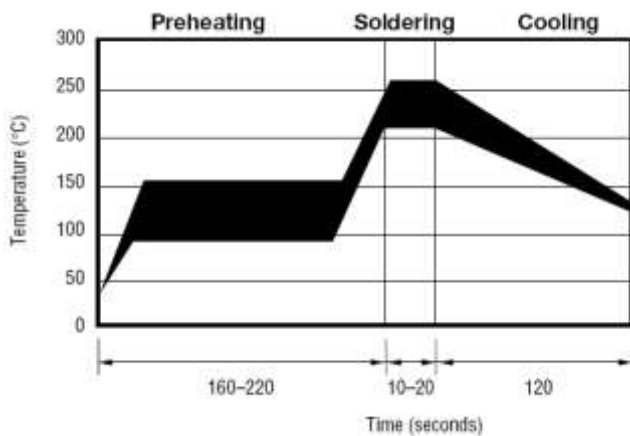

- Recommend reflow methods : IR, vapor phase oven, hot air oven.
 - Devices are not designed to be wave soldered to the bottom side of the board.
 - Recommended maximum paste thickness is 0.25 mm(0.010 inch).
 - Devices can be cleaned using standard method and solvents.
- Note : If reflow temperatures exceed the recommended profile, devices may not meet the performance requirements.



Lead Free SMD Resettable Fuse

Document No	TRF10OS000A
Issued date	2009/01/10
Page	5/7

9. Typical Part Marking

Represents total content. Layout may vary.

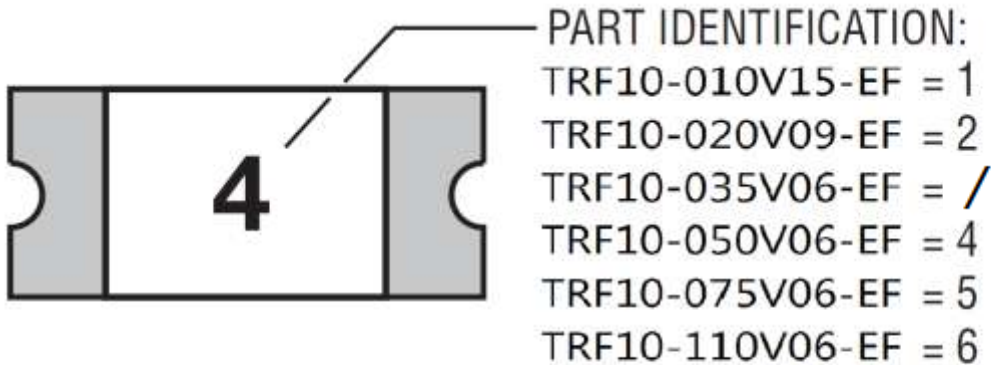

BIWEEKLY DATE CODE WILL APPEAR ON THE PACKAGING LABEL:
WEEK 1 AND 2 = A
WEEK 51 AND 52 = Z

10. Storage Conditions:

Temperature : 40°C max, Humidity : 40%~70%

11. Shelf Life:

2 years from manufacturing date



Lead Free SMD Resettable Fuse

Document No	TRF10OS000A
Issued date	2009/01/10
Page	6/7

12. Taping & Reel

Tape Dimensions	TRF10-010V15-EF TRF10-020V09-EF TRF10-035V06-EF TRF10-050V06-EF per EIA 481-1	TRF10-075V06-EF TRF10-110V06-EF per EIA 481-1
	W	$\frac{8.0 - 0.30}{(0.315 - 0.012)}$
P ₀	$\frac{4.0 - 0.10}{(0.157 - 0.004)}$	$\frac{4.0 - 0.10}{(0.157 - 0.004)}$
P ₁	$\frac{4.0 - 0.10}{(0.157 - 0.004)}$	$\frac{4.0 - 0.10}{(0.157 - 0.004)}$
P ₂	$\frac{2.0 - 0.05}{(0.079 - 0.002)}$	$\frac{2.0 - 0.05}{(0.079 - 0.002)}$
A ₀	$\frac{1.65 - 0.10}{(0.065 - 0.004)}$	$\frac{1.65 - 0.10}{(0.065 - 0.004)}$
B ₀	$\frac{2.4 - 0.10}{(0.094 - 0.004)}$	$\frac{2.4 - 0.10}{(0.094 - 0.004)}$
B ₁ max.	$\frac{4.35}{(0.171)}$	$\frac{4.35}{(0.171)}$
D ₀	$\frac{1.50 + 0.10/-0.0}{(0.059 + 0.004/-0)}$	$\frac{1.50 + 0.10/-0.0}{(0.059 + 0.004/-0)}$
F	$\frac{3.5 - 0.05}{(0.138 + 0.002)}$	$\frac{3.5 - 0.05}{(0.138 + 0.002)}$
E ₁	$\frac{1.75 - 0.10}{(0.069 - 0.004)}$	$\frac{1.75 - 0.10}{(0.069 - 0.004)}$
E ₂ min.	$\frac{6.25}{(0.246)}$	$\frac{6.25}{(0.246)}$
T max.	$\frac{0.6}{(0.024)}$	$\frac{0.6}{(0.024)}$
T ₁ max.	$\frac{0.10}{(0.004)}$	$\frac{0.10}{(0.004)}$
K ₀	$\frac{0.95 - 0.10}{(0.037 - 0.004)}$	$\frac{1.25 - 0.10}{(0.049 - 0.004)}$
Leader min.	$\frac{390}{(15.35)}$	$\frac{390}{(15.35)}$
Trailer min.	$\frac{160}{(6.30)}$	$\frac{160}{(6.30)}$
Reel Dimensions		
A max.	$\frac{185}{(7.28)}$	$\frac{185}{(7.28)}$
N min.	$\frac{50}{(1.97)}$	$\frac{50}{(1.97)}$
W ₁	$\frac{8.4 + 1.5/-0.0}{(0.331 + 0.059/-0)}$	$\frac{8.4 + 1.5/-0.0}{(0.331 + 0.059/-0)}$
W ₂ max.	$\frac{14.4}{(0.567)}$	$\frac{14.4}{(0.567)}$

UNIT = $\frac{\text{MM}}{\text{(INCHES)}}$

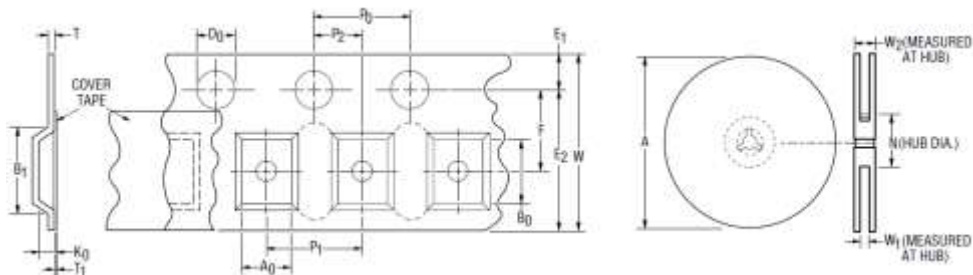

TA-I TECHNOLOGY CO., LTD

Specifications are subject to change without notice.
Customers should verify actual device performance in their specific applications.