

FastJack™ - 10G Vertical RJ45



1x1 Vertical 10G Integrated RJ45



Product Features:

- 10G Ethernet RJ45
- IEEE802.3an Compliant
- Compatible with Voltage Drive PHYs
- 100% Compliance Testing
- 1500Vrms Hi-Pot
- Hard Gold on Contacts
- UL60950 and UL62368 Recognized

Part Number		Data Rate	LED's (L/R)	Return Loss (MHz)			
Standard Temp (0 to 70°C)	Extended Temp (-40 to +85°C)			1-10	10-40	40-400	400-500
HFJV1-10G1RL	HFJV1-E10G1RL	10G	None	-13dB	-10dB	-7dB	-5dB
HFJV1-10G1-L11RL	HFJV1-E10G1-L11RL	10G	G/G	-13dB	-10dB	-7dB	-5dB
HFJV1-10G1-L12RL	HFJV1-E10G1-L12RL	10G	G/Y	-13dB	-10dB	-7dB	-5dB
HFJV1-10G1-L21RL	HFJV1-E10G1-L21RL	10G	Y/G	-13dB	-10dB	-7dB	-5dB

Notes:

1. LED Key : G = Green, Y = Yellow
2. Other single LED colors and bi-colors available
3. Part specific datasheets available upon request
4. Footprint interchangeable with other HALO [Vertical Gigabit FastJacks](#)

Circuit Diagram

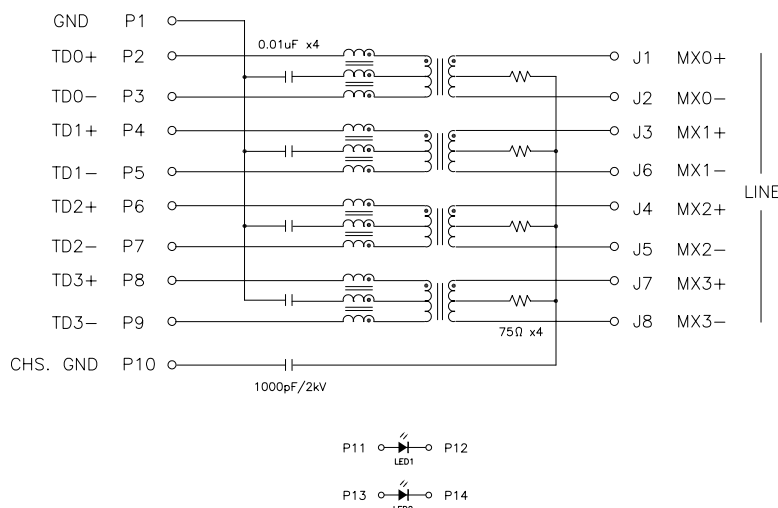

For additional information contact your [local representative](#), or HALO's support staff at (650) 903-3800 or info@haloelectronics.com

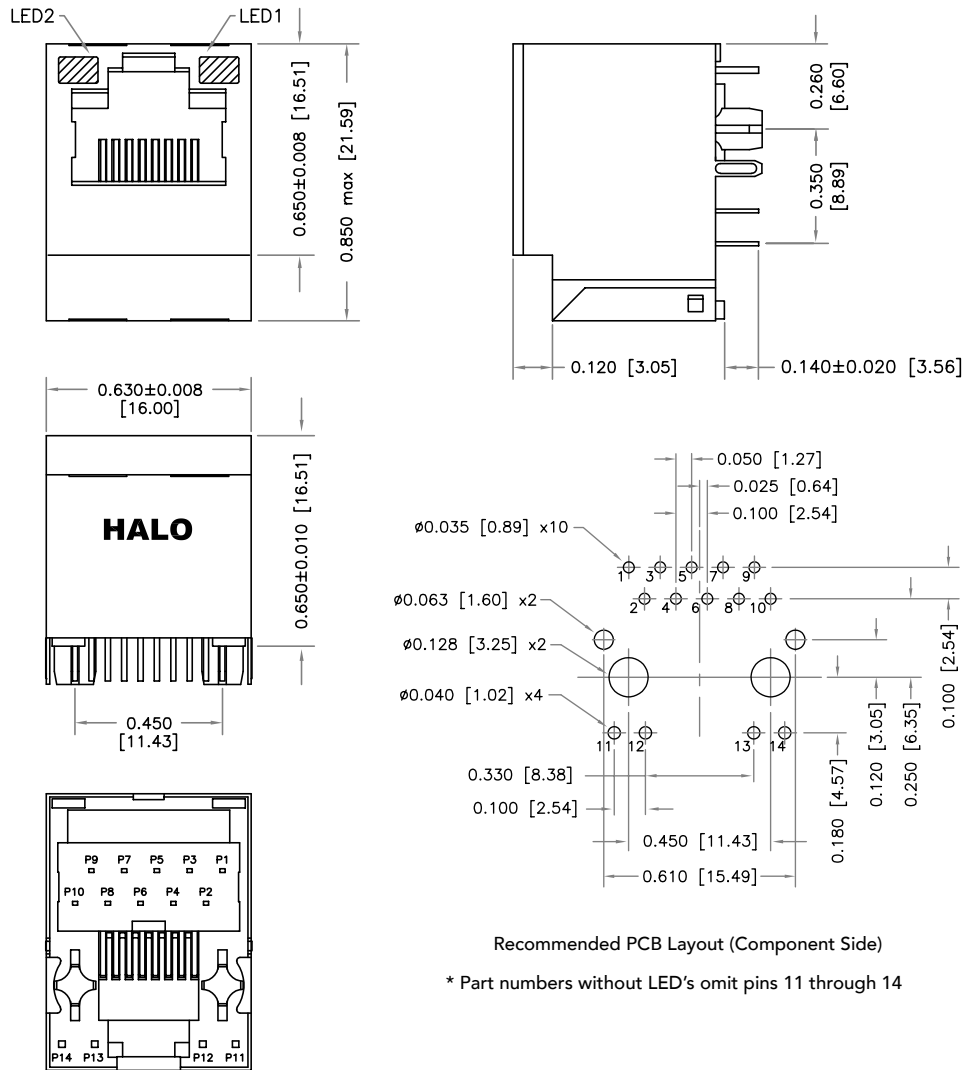

Dimensions are in inch [mm]

HALO
ELECTRONICS, INC.

Santa Clara, CA
(650) 903-3800

www.haloelectronics.com

HALO® Electronics is a leading supplier of high quality communication magnetics including signal transformers, filters, CMR chokes, PoE power transformers, DC/DC converters, and integrated Ethernet connectors. HALO's leading edge technology solutions are manufactured in ISO9001 and ISO14001 factories offering high quality products at a competitive price.