

## Four-Terminal Current-Sensing Wirewound Resistor

### 4LPW Series

- TC =  $\pm 40\text{ppm}/^\circ\text{C}$
- 3 watts to 15 watts
- 0.005 ohm to 1.0 ohm
- $\pm 1\%$ ,  $\pm 2\%$ ,  $\pm 3\%$ ,  $\pm 5\%$ ,  $\pm 10\%$  tolerance
- Flameproof construction

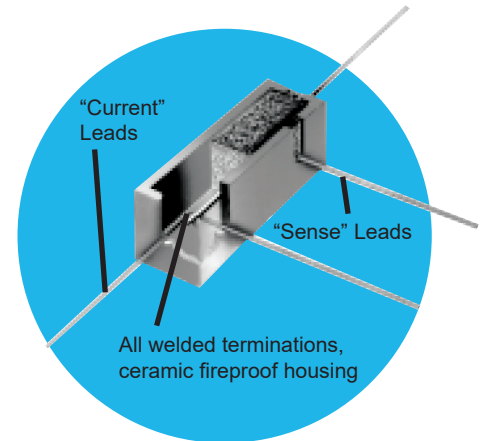

All Pb-free parts comply with EU Directive 2011/65/EU (RoHS2)

### Electrical Data

IRC Type	Power @ 25°C (watts)	Max. Current (amps)	Resistance Range (ohms)
4LPW-3	3	10	.005 TO 1.0
4LPW-5	5	10	.005 TO 1.0
4LPW-7	7	20	.01 TO 1.0
4LPW-10	10	20	.01 TO 1.0
4LPW-15	15	20	.01 TO 1.0

Please note: When ordering the alternate configuration please add an "A" after the part number. (4LPW-3A)

### Standard Configuration

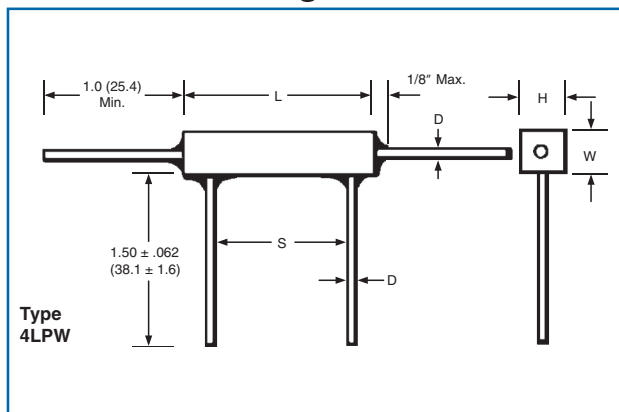

### Alternate Configuration

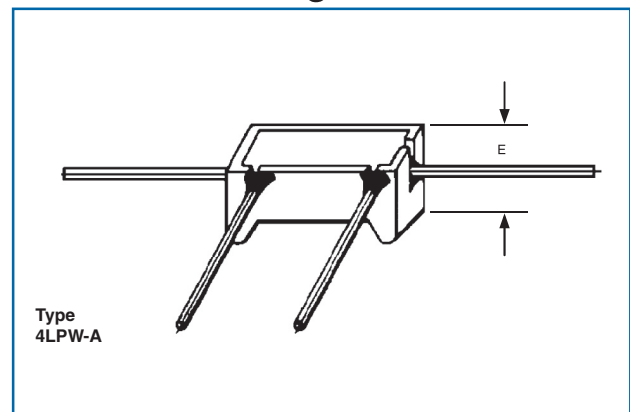

#### Dimensions (Inches (mm))

IRC Type	L $\pm .063$ (1.6)	W $\pm .03$ (.8)	H $\pm .03$ (.8)	S $\pm .062$ (1.6)	D Diameter	E $\pm .03$ (.8)
4LPW-3	.88 (22.4)	.31 (7.87)	.31 (7.87)	.563 (14.3)	.036 (.9)	.38 (9.65)
4LPW-5	.88 (22.4)	.38 (9.65)	.35 (8.89)	.563 (14.3)	.036 (.9)	.41 (10.4)
4LPW-7	1.39 (35.3)	.38 (9.65)	.35 (8.89)	1.013 (25.7)	.036 (.9)	.47 (11.9)
4LPW-10	1.88 (47.8)	.38 (9.65)	.35 (8.89)	1.388 (35.3)	.036 (.9)	.47 (11.9)
4LPW-15	1.88 (47.8)	.50 (12.7)	.50 (12.7)	1.388 (35.3)	.036 (.9)	.63 (16.0)

#### General Note

TT Electronics reserves the right to make changes in product specification without notice or liability. All information is subject to TT Electronics' own data and is considered accurate at time of going to print.

4LPW Series

### Temperature Rise Chart

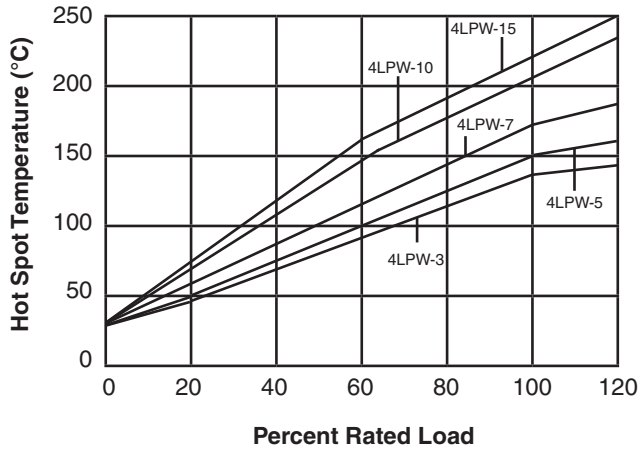

### Power Derating Curve

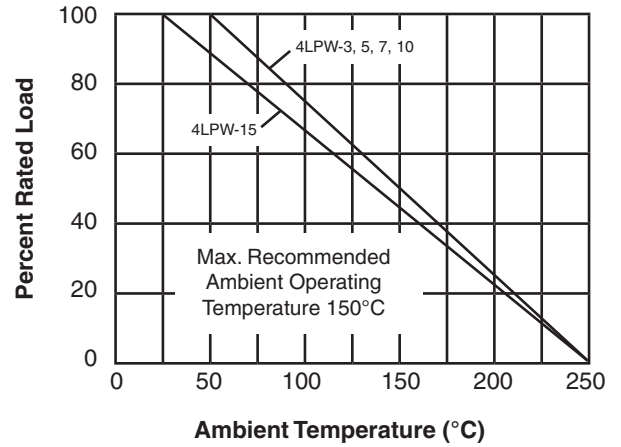

### Ordering Data

Sample Part No. ....	4LPW	15	R010	F	LF
IRC Type .....	4LPW				
Power .....	3 = 3W, 5 = 5W, 7 = 7W, 10 = 10W, 15 = 15W				
Resistance Range .....	Expressed in ohms (Standard EIA/MIL values)				
Tolerance .....	F = ±1%, G = ±2%, H = ±3%, J = ±5%, K = ±10%				
RoHS Indicator .....	LF indicates RoHS compliance / Omit this code for SnPb finish				

#### General Note

TT Electronics reserves the right to make changes in product specification without notice or liability. All information is subject to TT Electronics' own data and is considered accurate at time of going to print.