

# RoHS

## SPECIFICATIONS

Rated Current:3.0AMP  
 Contact Resistance:20mΩ Max  
 Withstand Voltage:1000V AC/DC  
 Insulation Resistance:1000MΩ Min  
 Operation Temperature:-40°c to +105°c

Contact Material:Brass  
 Contact Plating:Au Over Ni  
 Insulator Material:Polyester(UL94V-0)  
 Standard: PBT  
 Max.Processing Temp: 180°C for 30-60 seconds  
 (200°C for 10 seconds)

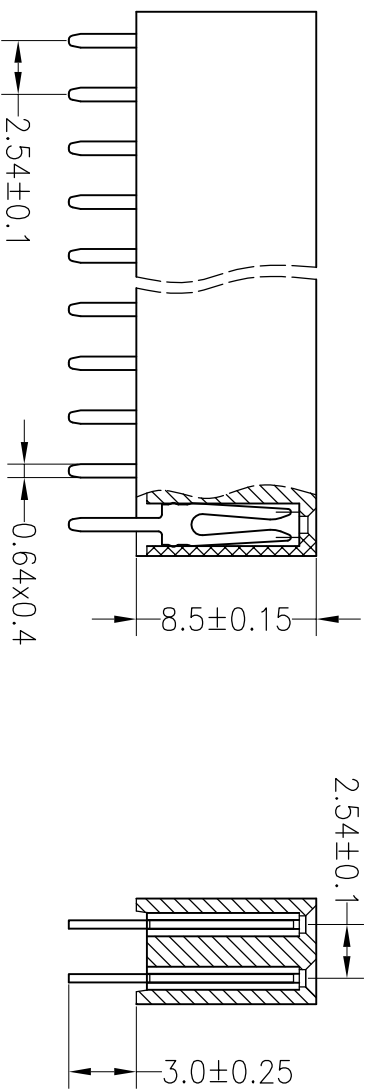
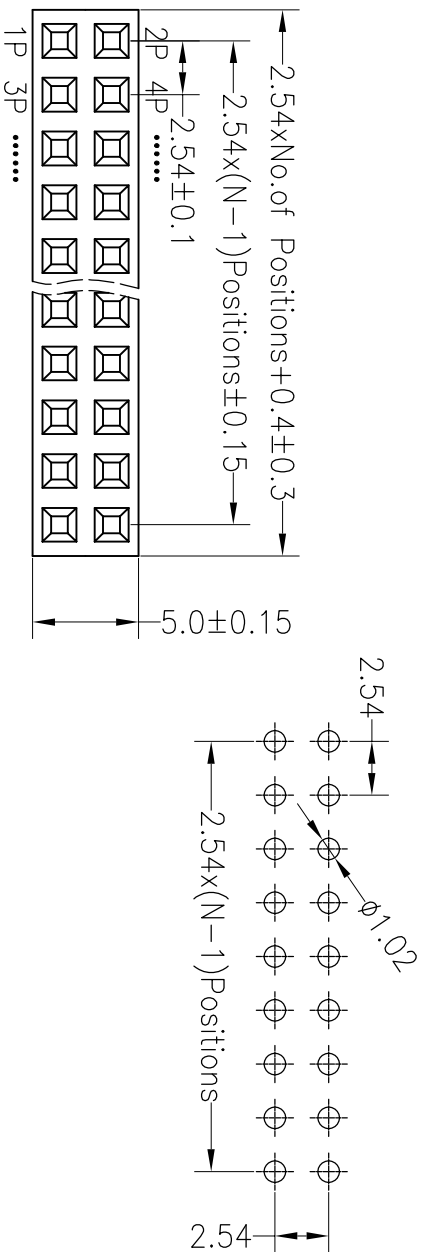

深圳市连盛精密连接器有限公司

PART NO. FH-00020

TITLE: 2.54FH H8.5 2x5pin 180° W5.0mm

OPERATION		DRAW		SCALE		FIT	
X.X	±0.30			UNIT	mm		
X.XX	±0.20	CHECK		SIZE	A4		
X.XXX	±0.10			SHEET	1/1		
Angle	±3°	APPROVE		PROJ.			
DIM	TOL						

REV	DATE	MODIFICATION DESCRIPTION	CHANGE
A0	2012.03.28	NEW DRAWING	
1			