

3-Electrode Gas Discharge Tube (GDT)

UN3E8 Series

Description

Gas discharge Tubes (GDT) are classical components for protecting the installations of the telecommunications. It is essential that IT and telecommunications systems -with their high-grade but sensitive electronic circuits - be protected by arresters. They are thus fitted at the input of the power supply system together with varistors and at the connection points to telecommunication lines. They have become equally indispensable for protecting base stations in mobile telephone systems as well as extensive cable television (CATV) networks with their repeaters and distribution systems.

These protective components are also indispensable in other sectors, In AC power transmission systems, they are often used with current-limiting varistors, In customer premises equipment such as DSL modems, WLAN routers, TV sets and cable modems In air-conditioning equipment, the integral black-box concept offers graduated protection by combining arresters with varistors, PTC, diodes and inductor.

Features

- u Non-Radioactive
- u RoHS compliant
- u Low insertion loss
- u Excellent response to fast rising transients
- u Ultra low capacitance
- u 20KA surge capability tested with 8/20µs pulse as defined by IEC 61000-4-5
- u Available with thermal failsafe option (add 'F' suffix to part number)

Applications

- u Communication equipment
- u CATV equipment
- u Test equipment
- u Data lines
- u Power supplies
- u Telecom SLIC protection
- u Broadband equipment
- u ADSL equipment, including ADSL2+
- u XDSL equipment
- u Satellite and CATV equipment
- u Consumer electronics

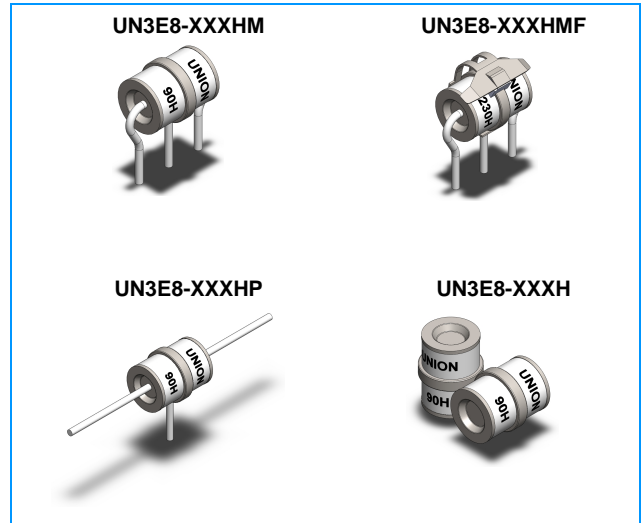

Schematic Symbol

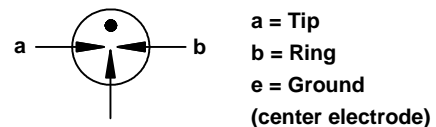

Agency Approvals

AGENCY	AGENCY FILE NUMBER
	E341061

Product Characteristics

Materials	Nickel-plated with Tinplated wires	
Product Marking	UNION XXXH XXX -Nominal voltage H -20KA	
Glow to Arc Transition Current	~1 Amps	
Glow Voltage	~70 Volts	
Storage and Operational Temperature	-40 to +90°C	
Weight	UN3E8-XXXHM	~2.0g
	UN3E8-XXXHMF	~2.3g
	UN3E8-XXXHP	~2.1g
	UN3E8-XXXH	~1.8g

3-Electrode Gas Discharge Tube (GDT)

UN3E8 Series

Dimensions (Unit: mm)

Radial Ledged Devices (UN3E8-XXXHM)

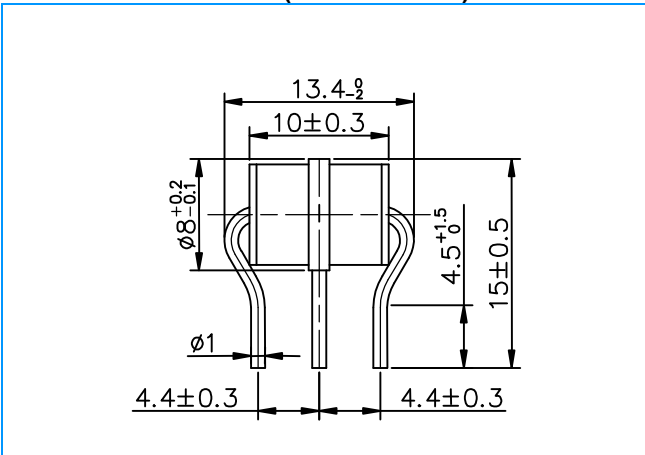

Radial Ledged Devices with Fail-Safe (UN3E8-XXXHMF)

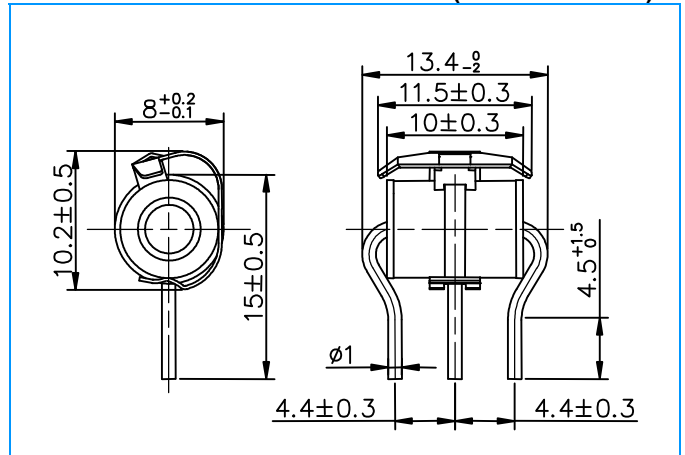

"T" Ledged Devices (UN3E8-XXXHP)

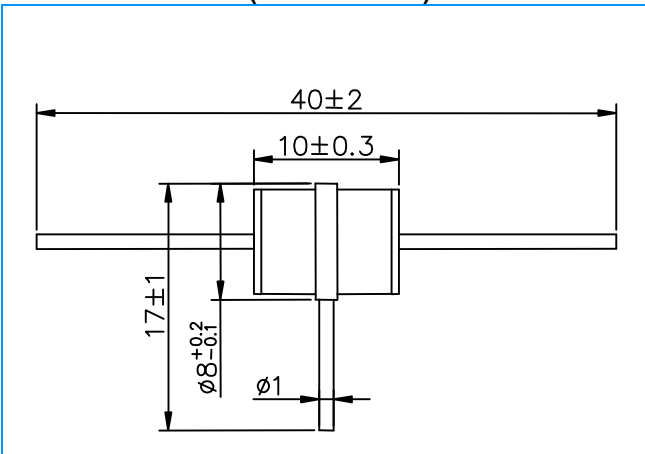

Without wire Devices (UN3E8-XXXH)

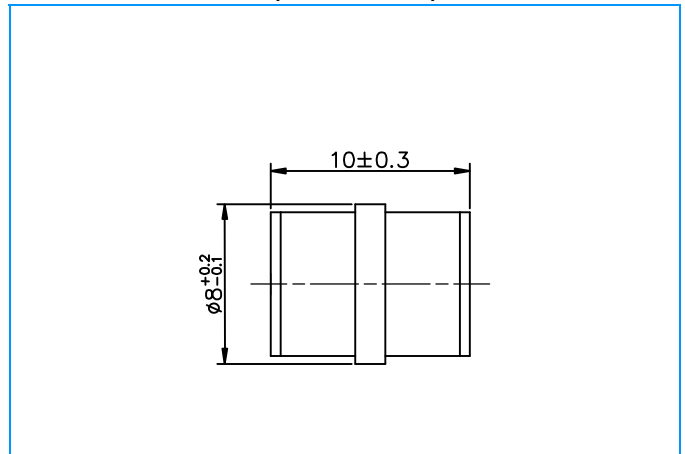

Electrical Characteristics

Part Number	Marking	DC Spark-over Voltage	Maximum Impulse Spark-over Voltage		Minimum Insulation Resistance	Maximum Capacitance	Arc Voltage	Service Life			
			@100V/μs	@1KV/μs				Nominal Impulse Discharge Current	Max Impulse Discharge Current	Nominal Alternating Discharge Current	Impulse Life
UN3E8-75HM UN3E8-75HMF UN3E8-75HP UN3E8-75H	UNION 75H	75V±20%	500V	600V	1 GΩ (at 25V)	1.5pF	~15V	20KA	25KA	20A	200A
UN3E8-90HM UN3E8-90HMF UN3E8-90HP UN3E8-90H	UNION 90H	90V±20%	500V	600V	1 GΩ (at 50V)	1.5pF	~15V	20KA	25KA	20A	200A

3-Electrode Gas Discharge Tube (GDT)

UN3E8 Series

Part Number	Marking	DC Spark-over Voltage	Maximum Impulse Spark-over Voltage		Minimum Insulation Resistance	Maximum Capacitance	Arc Voltage	Service Life			
								Nominal Impulse Discharge Current	Max Impulse Discharge Current	Nominal Alternating Discharge Current	Impulse Life
								@100V/S	@100V/μs	@1KV/μs	@1MHz
UN3E8-150HM UN3E8-150HMF UN3E8-150HP UN3E8-150H	UNION 150H	150V±20%	500V	600V	1 GΩ (at 50V)	1.5pF	~25V	20KA	25KA	20A	200A
UN3E8-230HM UN3E8-230HMF UN3E8-230HP UN3E8-230H	UNION 230H	230V±20%	600V	700V	1 GΩ (at 100V)	1.5pF	~25V	20KA	25KA	20A	200A
UN3E8-250HM UN3E8-250HMF UN3E8-250HP UN3E8-250H	UNION 250H	250V±20%	600V	700V	1 GΩ (at 100V)	1.5pF	~25V	20KA	25KA	20A	200A
UN3E8-300HM UN3E8-300HMF UN3E8-300HP UN3E8-300H	UNION 300H	300V±20%	800V	900V	1 GΩ (at 100V)	1.5pF	~25V	20KA	25KA	20A	200A
UN3E8-350HM UN3E8-350HMF UN3E8-350HP UN3E8-350H	UNION 350H	350V±20%	800V	900V	1 GΩ (at 100V)	1.5pF	~25V	20KA	25KA	20A	200A
UN3E8-420HM UN3E8-420HMF UN3E8-420HP UN3E8-420H	UNION 420H	420V±20%	900V	1000V	1 GΩ (at 100V)	1.5pF	~25V	20KA	25KA	20A	200A
UN3E8-470HM UN3E8-470HMF UN3E8-470HP UN3E8-470H	UNION 470H	470V±20%	900V	1000V	1 GΩ (at 100V)	1.5pF	~25V	20KA	25KA	20A	200A
UN3E8-600HM UN3E8-600HMF UN3E8-600HP UN3E8-600H	UNION 600H	600V±20%	1100V	1200V	1 GΩ (at 100V)	1.5pF	~25V	20KA	25KA	20A	200A
UN3E8-800HM UN3E8-800HMF UN3E8-800HP UN3E8-800H	UNION 800H	800V±20%	1200V	1400V	1 GΩ (at 100V)	1.5pF	~25V	20KA	25KA	20A	200A

Notes:

- 1). Terms in accordance with ITU-T K.12 and GB/T 9043-2008
- 2). At delivery AQL 0.65 level II, DIN ISO 2859
- 3). Tip or ring electrode to center electrode
- 4). Total current through center electrode, half value through tip respectively ring electrode

3-Electrode Gas Discharge Tube (GDT)

UN3E8 Series

Electrical Rating

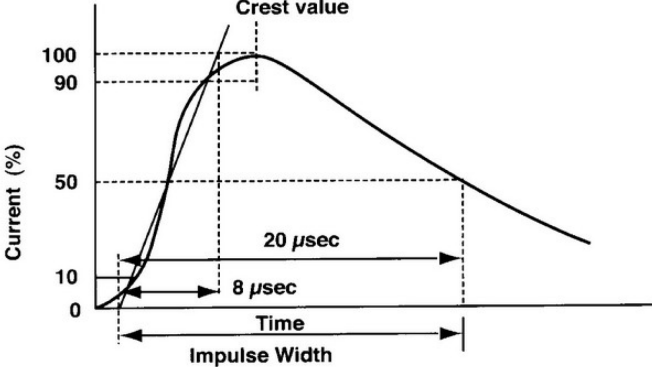
Item	Test Condition / Description	Requirement
DC Spark-over Voltage	The voltage is measured with a slowly rate of rise $dv / dt=100V/s$	To meet the specified value
Impulse Spark-over Voltage	The maximum impulse spark-over voltage is measured with a rise time of $dv / dt=100V/\mu s$ or $1KV/\mu s$	
Insulation Resistance	The resistance of gas tube shall be measured each terminal each other terminal, please see above spec.	
Capacitance	The capacitance of gas tube shall be measured each terminal to each other terminal. Test frequency :1MHz	
Nominal Impulse Discharge Current	The maximum current applying a waveform of $8/20\mu s$ that can be applied across the terminals of the gas tube. One hour after the test is completed, re-testing of the DC spark-over voltage does not exceed $\pm 30\%$ of the nominal DC spark-over voltage. Dwell time between pulses is 3 minutes. 	
Nominal Alternating Discharge Current	Rated RMS value of AC current at 50Hz, 1 sec. 10 times. Intervals: 3min. The DC spark-over voltage does not exceed $\pm 30\%$ of the nominal DC spark-over voltage. $IR > 10^8 ohms$.	

Recommended soldering profile

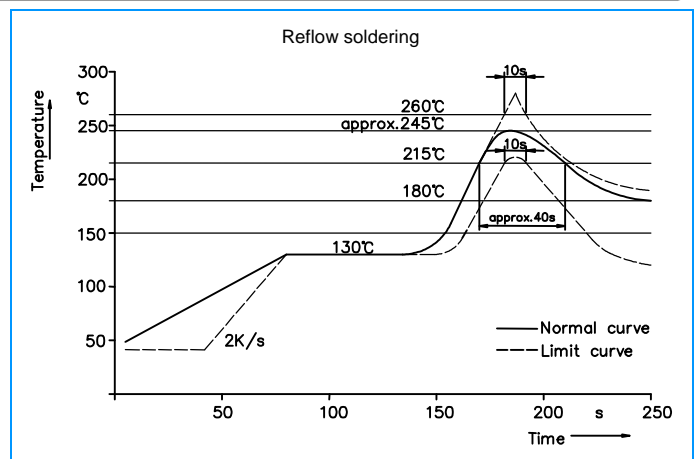
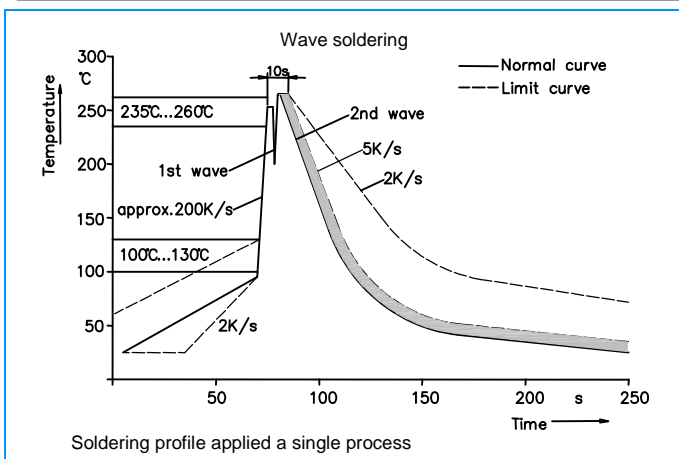

Soldering Parameters - Hand Soldering

Solder Iron Temperature: 350°C $\pm 5^\circ C$
 Heating Time: 5 seconds max.

3-Electrode Gas Discharge Tube (GDT)

UN3E8 Series

Part Numbering

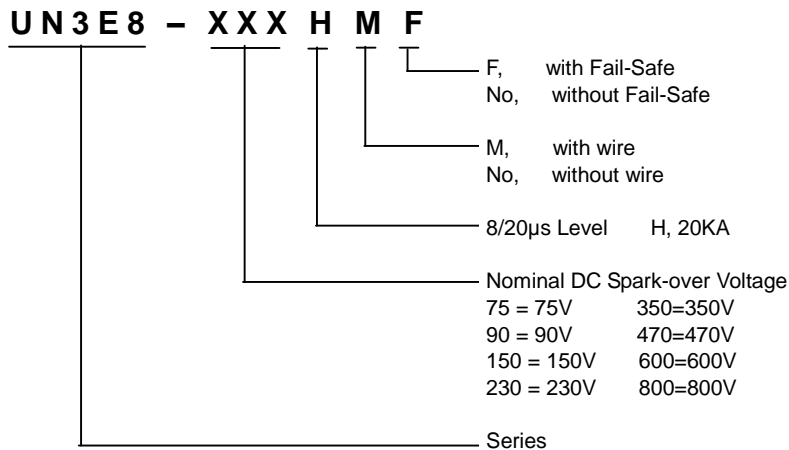

Packaging

Part Number	Description	Quantity
UN3E8-XXXHM	100PCS per Tray, 10 Trays / Inner Carton	1000
UN3E8-XXXHMF	100PCS per Tray, 10 Trays / Inner Carton	1000
UN3E8-XXXHP	50PCS per Tray, 10 Trays / Inner Carton	500
UN3E8-XXXH	100PCS per Tray, 10 Trays / Inner Carton	1000

Tray Dimension (Unit: mm)

Used in UN3E8-XXXHM, UN3E8-XXXHMF, UN3E8-XXXH

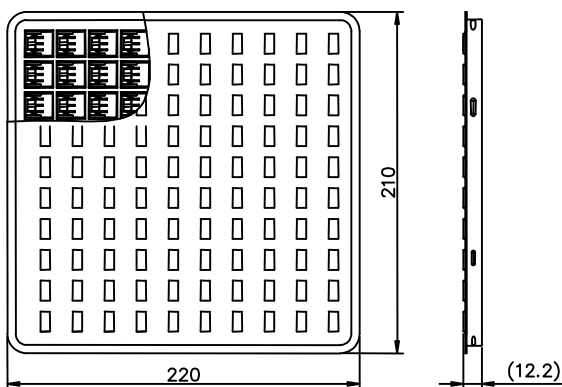

Tray Dimension (Unit: mm)

Used in UN3E8-XXXHP

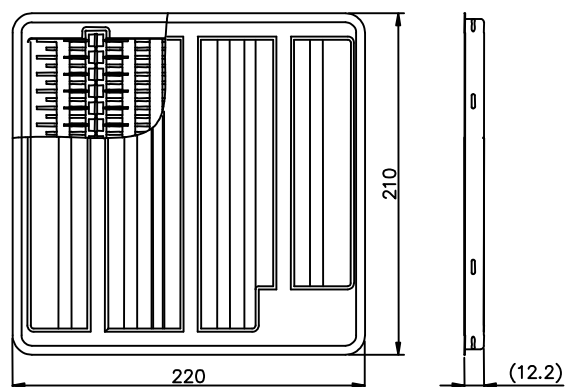

Cautions and warnings

- ⚠ Gas discharge tubes (GDT) must not be operated directly in power supply networks.
- ⚠ Gas discharge tubes (GDT) may become hot in case of longer periods of current stress (danger of burning).
- ⚠ Gas discharge tubes (GDT) may be used only within their specified values. In the event of overload, the head contacts may fail or the component may be destroyed.
- ⚠ Damaged Gas discharge tubes (GDT) must not be re-used.