

# MH4V6445BXJJ-5,-6,-5S,-6S

HYPER PAGE MODE 268435456-BIT (4194304-WORD BY 64-BIT)DYNAMIC RAM

## DESCRIPTION

This is family of 4194304 - word by 64 - bit dynamic RAM module. This consists of four industry standard 4Mx16 dynamic RAMs in TSOP and one industry EEPROM in TSSOP.

The mounting of TSOP on a card edge dual in line package provides any application where high densities and large of quantities memory are required.

This is a socket-type memory module,suitable for easy interchange of addition of modules.

## FEATURES

	RAS access time (max.ns)	CAS access time (max.ns)	Address access time (max.ns)	OE access time (max.ns)	Cycle time (min.ns)
MH4V6445BXJJ-5,5S	50	13	25	13	84
MH4V6445BXJJ-6,6S	60	15	30	15	104

- single 3.3V± 0.3V supply
- Low stand-by power dissipation  
7.2mW- ----- LVCMOS input level
- operating power dissipation  
MH4V6445BXJJ-5,5S ----- 2016 mW(max.)  
MH4V6445BXJJ-6,6S ----- 1872 mW(max.)

- Self refresh capability\*  
Self refresh current ----- 1600 uA(max.)
- All input, output LVTTTL compatible and low capacitance
- Utilizes industry standard 4Mx16 RAMs in TSOP and industry standard EEPROM in TSSOP.
- Includes decoupling capacitor(0.22uF×4)
- Hyper page mode , Read-modify-write, CAS before RAS refresh,Hidden refresh capabilities.
- Early-write mode,OE and W to control output buffer impedance.

## ADDRESS

Part No.	Row Add.	Col Add.	Refresh	Refresh Cycle	
				Normal	S-Version
MH4V6445BXJJ	A0~A11	A0~A9	/RAS only Ref,Normal R/W CBR Ref,Hidden Ref	4096/64ms	4096/128ms

## APPLICATION

Main memory unit for computer, Microcomputer memory, Refresh memory for CRT.

\*:Applicable to self refresh version(MH4V645/6445AXJJ-5S,-6S) only

# MH4V6445BXJJ-5,-6,-5S,-6S

HYPER PAGE MODE 268435456-BIT (4194304-WORD BY 64-BIT)DYNAMIC RAM

## PIN CONFIGURATION

PIN Number	Front side Pin Name	PIN Number	Back side Pin Name	PIN Number	Front side Pin Name	PIN Number	Back side Pin Name
1	Vss	2	Vss	73	/OE	74	RFU
3	DQ0	4	DQ32	75	Vss	76	Vss
5	DQ1	6	DQ33	77	Reserved	78	Reserved
7	DQ2	8	DQ34	79	Reserved	80	Reserved
9	DQ3	10	DQ35	81	Vcc	82	Vcc
11	Vcc	12	Vcc	83	DQ16	84	DQ48
13	DQ4	14	DQ36	85	DQ17	86	DQ49
15	DQ5	16	DQ37	87	DQ18	88	DQ50
17	DQ6	18	DQ38	89	DQ19	90	DQ51
19	DQ7	20	DQ39	91	Vss	92	Vss
21	Vss	22	Vss	93	DQ20	94	DQ52
23	/CAS0	24	/CAS4	95	DQ21	96	DQ53
25	/CAS1	26	/CAS5	97	DQ22	98	DQ54
27	Vcc	28	Vcc	99	DQ23	100	DQ55
29	A0	30	A3	101	Vcc	102	Vcc
31	A1	32	A4	103	A6	104	A7
33	A2	34	A5	105	A8	106	A11
35	Vss	36	Vss	107	Vss	108	Vss
37	DQ8	38	DQ40	109	A9	110	NC
39	DQ9	40	DQ41	111	A10	112	NC
41	DQ10	42	DQ42	113	Vcc	114	Vcc
43	DQ11	44	DQ43	115	/CAS2	116	/CAS6
45	Vcc	46	Vcc	117	/CAS3	118	/CAS7
47	DQ12	48	DQ44	119	Vss	120	Vss
49	DQ13	50	DQ45	121	DQ24	122	DQ56
51	DQ14	52	DQ46	123	DQ25	124	DQ57
53	DQ15	54	DQ47	125	DQ26	126	DQ58
55	Vss	56	Vss	127	DQ27	128	DQ59
57	Reserved	58	Reserved	129	Vcc	130	Vcc
59	Reserved	60	Reserved	131	DQ28	132	DQ60
61	RFU	62	FRU	133	DQ29	134	DQ61
63	Vcc	64	Vcc	135	DQ30	136	DQ62
65	RFU	66	RFU	137	DQ31	138	DQ63
67	/WE	68	RFU	139	Vss	140	Vss
69	/RAS0	70	RFU	141	SDA	142	SCL
71	NC	72	RFU	143	Vcc	144	Vcc

RFU:Reserved Future Use  
NC,RFU,Reserved: NO CONNECTION

# MH4V6445BXJJ-5,-6,-5S,-6S

HYPER PAGE MODE 268435456-BIT (4194304-WORD BY 64-BIT) DYNAMIC RAM

## Block Diagram

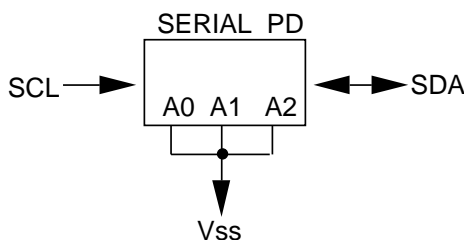
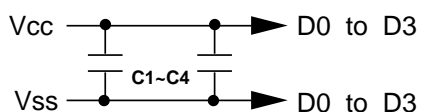
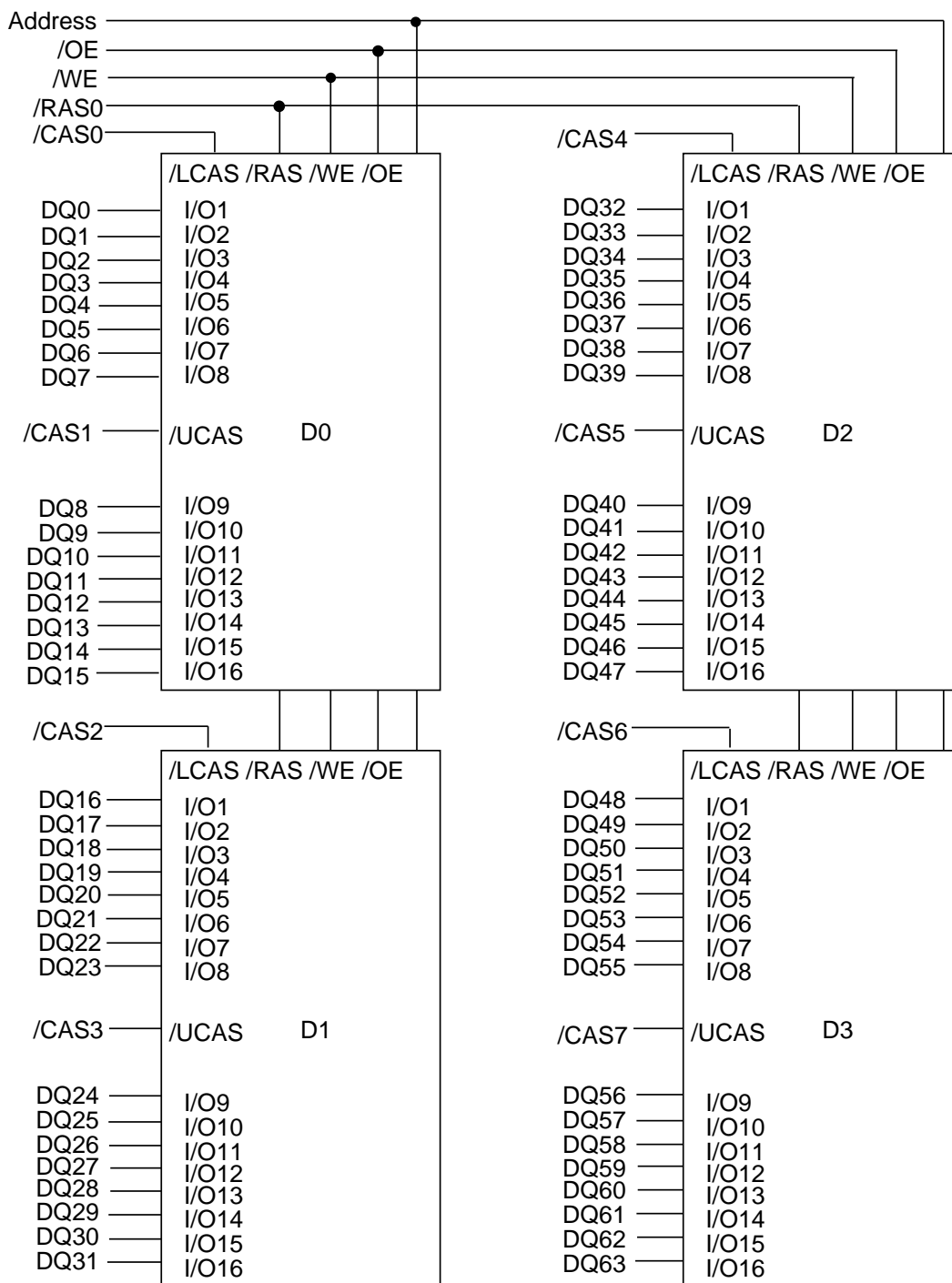

# MH4V6445BXJJ-5,-6,-5S,-6S

HYPER PAGE MODE 268435456-BIT (4194304-WORD BY 64-BIT)DYNAMIC RAM

## FUNCTION

The MH4V6445BXJJ provide, in addition to normal read, write, and read-modify-write operations, a number of other functions, e.g., Hyper page mode, /RAS-only refresh, and delayed-write. The input conditions for each are shown in Table 1.

Table 1 Input conditions for each mode

Operation	Inputs						Input/Output		Refresh	Remark
	/RAS	/CAS	/W	/OE	Row address	Column address	Input	Output		
Read	ACT	ACT	NAC	ACT	APD	APD	OPN	VLD	YES	Hyper page mode identical
Write (Early write)	ACT	ACT	ACT	DNC	APD	APD	VLD	OPN	YES	
Write (Delayed write)	ACT	ACT	ACT	DNC	APD	APD	VLD	IVD	YES	
Read-modify-write	ACT	ACT	ACT	ACT	APD	APD	VLD	VLD	YES	
/RAS-only refresh	ACT	NAC	DNC	DNC	APD	DNC	DNC	OPN	YES	
Hidden refresh	ACT	ACT	NAC	ACT	APD	DNC	OPN	VLD	YES	
/CAS before /RAS refresh	ACT	ACT	NAC	DNC	DNC	DNC	DNC	OPN	YES	
Standby	NAC	DNC	DNC	DNC	DNC	DNC	DNC	OPN	NO	
Self refresh *	ACT	ACT	NAC	DNC	DNC	DNC	DNC	OPN	YES	

Note : ACT : active, NAC : nonactive, DNC : don' t care, VLD : valid, IVD : Invalid, APD : applied, OPN : open

\*MH4V6445BXJJ-5S,-6S only

# MH4V6445BXJJ-5,-6,-5S,-6S

HYPER PAGE MODE 268435456-BIT (4194304-WORD BY 64-BIT)DYNAMIC RAM

## ABSOLUTE MAXIMUM RATINGS

Symbol	Parameter	Conditions	Ratings	Unit
Vcc	Supply voltage	With respect to Vss	-0.5~4.6	V
VI	Input voltage		-0.5~4.6	V
VO	Output voltage		-0.5~4.6	V
IO	Output current		50	mA
Pd	Power dissipation	Ta=25°C	4	W
Topr	Operating temperature		0~ 70	°C
Tstg	Storage temperature		-40~ 100	°C

## RECOMMENDED OPERATING CONDITIONS (Ta=0~ 70°C, unless otherwise noted) (Note 1)

Symbol	Parameter	Limits			Unit
		Min	Nom	Max	
Vcc	Supply voltage	3.0	3.3	3.6	V
Vss	Supply voltage	0	0	0	V
VIH	High-level input voltage, all inputs	2.0		Vcc+0.3	V
VIL	Low-level input voltage, all inputs	-0.3		0.8	V

Note 1 : All voltage values are with respect to Vss

## ELECTRICAL CHARACTERISTICS (Ta=0~70°C, Vcc=3.3V±0.3V, Vss=0V, unless otherwise noted) (Note 2)

Symbol	Parameter	Test conditions	Limits			Unit
			Min	Typ	Max	
VOH	High-level output voltage	IOH=-2.0mA	2.4		Vcc	V
VOL	Low-level output voltage	IOL=2.0mA	0		0.4	V
IOZ	Off-state output current	Q floating 0V VOUT 3.6V	-10		10	uA
II	Input current	0V VIN 3.6V, Other input pins=0V	-40		40	uA
ICC1 (AV)	Average supply current from Vcc operating (Note 3,4,5)	-5,-5S /RAS, /CAS cycling tRC=tWC=min. output open			560	mA
		-6,-6S			520	
ICC2	Supply current from Vcc , stand-by	/RAS=/CAS =VIH, output open			4	mA
		/RAS=/CAS Vcc -0.2, output open			2	
ICC4(AV)	Average supply current from Vcc Hyper-Page-Mode (Note 3,4,5)	-5,-5S /RAS=VIL,/CAS cycling tPC=min.			480	mA
		-6,-6S output open			440	
ICC6(AV)	Average supply current from Vcc /CAS before /RAS refresh mode (Note 3,5)	-5,-5S /CAS before /RAS refresh cycling tRC=min.			560	mA
		-6,-6S output open			520	

Note 2: Current flowing into an IC is positive, out is negative.

3: Icc1 (AV), Icc4 (AV) and Icc6 (AV) are dependent on cycle rate. Maximum current is measured at the fastest cycle rate.

4: Icc1 (AV) and Icc4 (AV) are dependent on output loading. Specified values are obtained with the output open.

5: Column address can be changed once or less while /RAS=VIL and /CAS=VOH

## CAPACITANCE (Ta = 0~70°C, Vcc = 3.3V±0.3V, Vss = 0V, unless otherwise noted)

Symbol	Parameter	Test conditions	Limits			Unit
			Min	Typ	Max	
CI (A)	Input capacitance, address inputs	VI=Vss f=1MHz Vi=25mVrms			40	pF
CI	Input capacitance, clock inputs except CAS				45	pF
C(CAS)	Input capacitance, CAS				25	pF
C(DQ)	Input/Output capacitance, DATA				25	pF
C(SDA)	Input/Output capacitance, SDA				12	pF
C(SCL)	Input capacitance, SCL				12	pF

# MH4V6445BXJJ-5,-6,-5S,-6S

HYPER PAGE MODE 268435456-BIT (4194304-WORD BY 64-BIT)DYNAMIC RAM

## SWITCHING CHARACTERISTICS (Ta=0~70°C, Vcc=3.3V±0.3V, Vss=0V, unless otherwise noted, see notes 6,14,15)

Symbol	Parameter	Limits				Unit
		-5,-5S		-6,-6S		
		Min	Max	Min	Max	
tCAC	Access time from /CAS (Note 7,8)		13		15	ns
tRAC	Access time from /RAS (Note 7,9)		50		60	ns
tAA	Column address access time (Note 7,10)		25		30	ns
tCPA	Access time from /CAS precharge (Note 7,11)		28		33	ns
tOEA	Access time from /OE (Note 7)		13		15	ns
tOHC	Output hold time /CAS high	5		5		ns
tOHR	Output hold time /RAS high (Note 13)	5		5		ns
tCLZ	Output low impedance time from /CAS low (Note 7)	5		5		ns
tOEZ	Output disable time after /OE high (Note 12)		13		15	ns
tWEZ	Output disable time after /WE high (Note 12)		13		15	ns
tOFF	Output disable time after /CAS high (Note 12,13)		13		15	ns
tREZ	Output disable time after /RAS high (Note 12,13)		13		15	ns
tDOH	Output hold time from /CAS low	5		5		ns

Note 6: An initial pause of 500us is required after power-up followed by a minimum of eight initialization cycles (any combination of cycles containing a /RAS clock such as /RAS-Only refresh).

Note the /RAS may be cycled during the initial pause. And any 8 /RAS or /RAS /CAS cycles are required after prolonged periods (greater than 64 ms) of /RAS inactivity before proper device operation is achieved.

7: Measured with a load circuit equivalent to 100pF. The reference levels for measuring of output signals are 2.0(VOH)and 0.8(VOL).

8: Assumes that tRCD tRCD(max), tASC tASC(max) and tCP tCP(max).

9: Assumes that tRCD tRCD(max) and tRAD tRAD(max). If tRCD or tRAD is greater than the maximum recommended value shown in this table,tRAC will increase by amount that tRCD exceeds the value shown.

10: Assumes that tRAD tRAD(max) and tASC tASC(max).

11: Assumes that tCP tCP(max) and tASC tASC(max).

12: tOEZ (max), tWEZ(max), tOFF(max) and tREZ(max) defines the time at which the output achieves the high impedance state (IOUT ±10uA) and is not reference to VOH(min) or VOL(max).

13: Output is disable after both /RAS and /CAS go to high

## TIMING REQUIREMENTS (For Read, Write, Read-Modify-Write, Refresh, and Hyper-Page Mode Cycles)

(Ta=0~70°C, Vcc=3.3V±0.3V, Vss=0V, unless otherwise noted, see notes 14,15)

Symbol	Parameter	Limits				Unit
		-5,-5S		-6,-6S		
		Min	Max	Min	Max	
tREF	Refresh cycle time		64		64	ms
tREF	Refresh cycle time(S-version ONLY)		128		128	ms
tRP	/RAS high pulse width	30		40		ns
tRCD	Delay time, /RAS low to /CAS low (Note16)	14	37	14	45	ns
tCRP	Delay time, /CAS high to /RAS low	5		5		ns
tRPC	Delay time, /RAS high to /CAS low	0		0		ns
tCPN	/CAS high pulse width	8		10		ns
tRAD	Column address delay time from /RAS low (Note17)	10	25	12	30	ns
tASR	Row address setup time before /RAS low	0		0		ns
tASC	Column address setup time before /CAS low (Note18)	0	10	0	13	ns
tRAH	Row address hold time after /RAS low	8		10		ns
tCAH	Column address hold time after /CAS low	8		10		ns
tDZC	Delay time, data to /CAS low (Note19)	0		0		ns
tDZO	Delay time, data to /OE low (Note19)	0		0		ns
tRDD	Delay time, /RAS high to data (Note20)	13		15		ns
tCDD	Delay time, /CAS high to data (Note20)	13		15		ns
tODD	Delay time, /OE high to data (Note20)	13		15		ns
tT	Transition time (Note21)	1	50	1	50	ns

Note 14: The timing requirements are assumed tT =2ns.

15: VIH(min) and VIL(max) are reference levels for measuring timing of input signals.

16: tRCD(max) is specified as a reference point only. If tRCD is less than tRCD(max), access time is tRAC. If tRCD is greater than tRCD(max), access time is controlled exclusively by tCAC or tAA.

17: tRAD(max) is specified as a reference point only. If tRAD tRAD(max) and tASC tASC(max), access time is controlled exclusively by tAA.

18: tASC(max) is specified as a reference point only. If tRCD tRCD(max) and tASC tASC(max), access time is controlled exclusively by tCAC.

19: Either tDZC or tDZO must be satisfied.

20: Either tRDD or tCDD or tODD must be satisfied.

21: tT is measured between VIH(min) and VIL(max).

# MH4V6445BXJJ-5,-6,-5S,-6S

HYPER PAGE MODE 268435456-BIT (4194304-WORD BY 64-BIT)DYNAMIC RAM

## Read and Refresh Cycles

Symbol	Parameter	Limits				Unit
		-5,-5S		-6,-6S		
		Min	Max	Min	Max	
tRC	Read cycle time	84		104		ns
tRAS	/RAS low pulse width	50	10000	60	10000	ns
tCAS	/CAS low pulse width	8	10000	10	10000	ns
tCSH	/CAS hold time after /RAS low	35		40		ns
tRSH	/RAS hold time after /CAS low	13		15		ns
tRCS	Read Setup time after /CAS high	0		0		ns
tRCH	Read hold time after /CAS low (Note 22)	0		0		ns
tRRH	Read hold time after /RAS low (Note 22)	0		0		ns
tRAL	Column address to /RAS hold time	25		30		ns
tCAL	Column address to /CAS hold time	13		18		ns
tORH	/RAS hold time after /OE low	13		15		ns
tOCH	/CAS hold time after /OE low	13		15		ns

Note 22: Either tRCH or tRRH must be satisfied for a read cycle.

## Write Cycle (Early Write and Delayed Write)

Symbol	Parameter	Limits				Unit
		-5,-5S		-6,-6S		
		Min	Max	Min	Max	
tWC	Write cycle time	84		104		ns
tRAS	/RAS low pulse width	50	10000	60	10000	ns
tCAS	/CAS low pulse width	8	10000	10	10000	ns
tCSH	/CAS hold time after /RAS low	35		40		ns
tRSH	/RAS hold time after /CAS low	13		15		ns
tWCS	Write setup time before /CAS low (Note 24)	0		0		ns
tWCH	Write hold time after /CAS low	8		10		ns
tCWL	/CAS hold time after /W low	8		10		ns
tRWL	/RAS hold time after /W low	8		10		ns
tWP	Write pulse width	8		10		ns
tDS	Data setup time before /CAS low or /W low	0		0		ns
tDH	Data hold time after /CAS low or /W low	8		10		ns

## Read-Write and Read-Modify-Write Cycles

Symbol	Parameter	Limits				Unit
		-5,-5S		-6,-6S		
		Min	Max	Min	Max	
tRWC	Read write/read modify write cycle time (Note21)	109		133		ns
tRAS	/RAS low pulse width	75	10000	89	10000	ns
tCAS	/CAS low pulse width	38	10000	44	10000	ns
tCSH	/CAS hold time after /RAS low	70		82		ns
tRSH	/RAS hold time after /CAS low	38		44		ns
tRCS	Read setup time before /CAS low	0		0		ns
tCWD	Delay time, /CAS low to /W low (Note24)	28		32		ns
tRWD	Delay time, /RAS low to /W low (Note24)	65		77		ns
tAWD	Delay time, address to /W low (Note24)	40		47		ns
tOEH	/OE hold time after /W low	13		15		ns

Note 23: tRWC is specified as tRWC(min)=tRAC(max)+tODD(min)+tRWL(min)+tRP(min)+4tT.

24:tWCS, tCWD,tRWD ,tAWD and,tCPWD are specified as reference points only. If tWCS tWCS(min) the cycle is an early write cycle and the DQ pins will remain high impedance throughout the entire cycle. If tCWD tCWD(min), tRWD tRWD (min), tAWD tAWD(min) and tCPWD tCPWD(min) (for Hyper page mode cycle only), the cycle is a read-modify-write cycle and the DQ will contain the data read from the selected address. If neither of the above condition (delayed write) of the DQ (at access time and until /CAS or /OE goes back to VIH) is indeterminate.

# MH4V6445BXJJ-5,-6,-5S,-6S

HYPER PAGE MODE 268435456-BIT (4194304-WORD BY 64-BIT)DYNAMIC RAM

## Hyper Page Mode Cycle (Read, Early Write, Read -Write, Read-Modify-Write Cycle, Read Write Mix Cycle,Hi-Z control by /OE or /WE) (Note 25)

Symbol	Parameter	Limits				Unit
		-5,-5S		-6,-6S		
		Min	Max	Min	Max	
tHPC	Hyper page mode read/write cycle time	20		25		ns
tHPRWC	Hyper page mode read write/read modify write cycle time	55		66		ns
tRAS	/RAS low pulse width for read write cycle (Note26)	65	100000	77	100000	ns
tCP	/CAS high pulse width (Note27)	8	13	10	16	ns
tCPRH	/RAS hold time after /CAS precharge	28		33		ns
tCPWD	Delay time, /CAS precharge to /W low (Note24)	43		50		ns
tCHOL	Hold time to maintain the data Hi-Z until /CAS access	7		7		ns
tOEPE	/OE Pulse Width (Hi-Z control)	7		7		ns
tWPE	/W Pulse Width (Hi-Z control)	7		7		ns
tHCWD	Delay time, /CAS low to /W low after read	28		32		ns
tHAWD	Delay time, Address to /W low after read	40		47		ns
tHPWD	Delay time, /CAS precharge to /W low after read	43		50		ns
tHCOD	Delay time, /CAS low to /OE high after read	13		15		ns
tHAOD	Delay time, Address to /OE high after read	25		30		ns
tHPOD	Delay time, /CAS precharge to /OE high after read	28		33		ns

Note 25: All previously specified timing requirements and switching characteristics are applicable to their respective Hyper page mode cycle.

26: tRAS(min) is specified as two cycles of /CAS input are performed.

27: tCP(max) is specified as a reference point only.If tCP tCP(max),access time is controlled exclusively by tCAC.

## /CAS before /RAS Refresh Cycle (Note 28)

Symbol	Parameter	Limits				Unit
		-5,-5S		-6,-6S		
		Min	Max	Min	Max	
tCSR	/CAS setup time before /RAS low	5		5		ns
tCHR	/CAS hold time after /RAS low	10		10		ns
tRSR	Read setup time before /RAS low	10		10		ns
tRHR	Read hold time after /RAS low	10		10		ns

Note 28: Eight or more /CAS before /RAS cycles instead of eight /RAS cycles are necessary for proper operation of /CAS before /RAS refresh mode.

# MH4V6445BXJJ-5,-6,-5S,-6S

HYPER PAGE MODE 268435456-BIT (4194304-WORD BY 64-BIT)DYNAMIC RAM

## SELF REFRESH SPECIFICATIONS

Self refresh devices are denoted by "S" after speed item,line -5S / -6S. The other characteristics and requirements then below are same as normal device.

## ELECTRIC CHARACTERISTICS (Ta=0~70°C, Vcc=3.3V±0.3V, Vss=0V, unless otherwise noted) (Note 2)

Symbol	Parameter	Test conditions	Limits			Unit
			Min	Typ	Max	
ICC9(AV)*	Average supply current from Vcc Self-Refresh mode (Note 6)	-5S,-6S /RAS=/CAS<0.2V /OE=W=A0~A12(A11)=Vcc-0.2V or 0.2V output=Vcc-0.2V,0.2V or open			1600	µA

## TIMING REQUIREMENTS (Ta=0~70°C, Vcc=3.3V±0.3V, Vss=0V, unless otherwise noted ,see notes 13,14)

Symbol	Parameter	Limits				Unit
		-5S		-6S		
		Min	Max	Min	Max	
tRASS	CBR Self Refresh RAS low pulse width	100		100		us
tRPS	CBR Self Refresh RAS high precharge time	84		104		ns
tCHS	CBR Self Refresh RAS hold time	- 50		- 50		ns

## SELF REFRESH ENTRY & EXIT CONDITIONS

### (1) In case of CBR distributed refresh

The last / first full refresh cycles must be made within tNS / tSN before / after self refresh , on the condition of tNS 128 ms and tSN 128 ms.

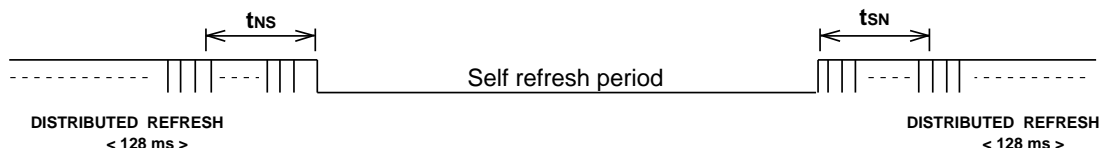

### (2) In case of burst refresh

The last / first full refresh cycles must be made within tNS / tSN before / after self refresh , on the condition of tNS 16ms and tSN 16 ms.

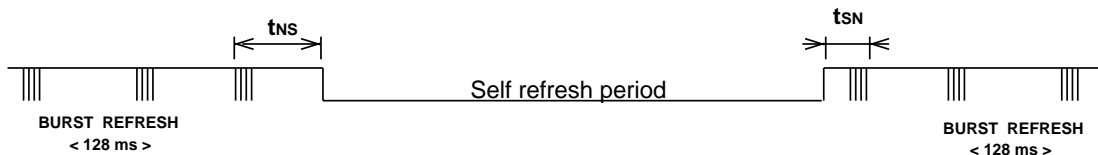



# MH4V6445BXJJ-5,-6,-5S,-6S

HYPER PAGE MODE 268435456-BIT (4194304-WORD BY 64-BIT) DYNAMIC RAM

## Timing Diagrams (Note 29)

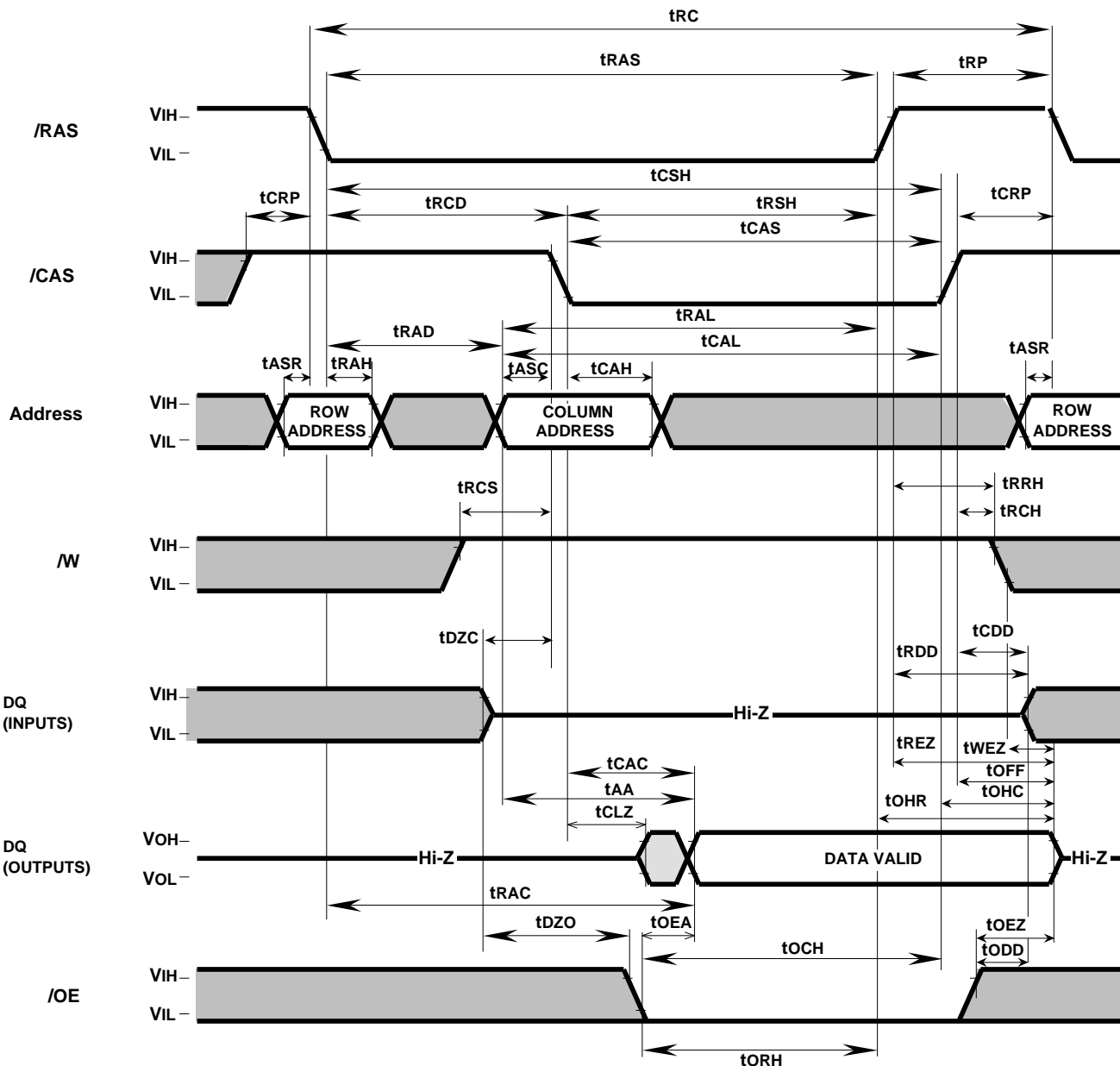
### Read Cycle



Note 29  Indicates the don't care input.  
 $V_{\text{IH}}(\text{min})$   $V_{\text{IN}}$   $V_{\text{IH}}(\text{max})$  or  $V_{\text{IL}}(\text{min})$   $V_{\text{IN}}$   $V_{\text{IL}}(\text{max})$   
 Indicates the invalid output.

# MH4V6445BXJJ-5,-6,-5S,-6S

HYPER PAGE MODE 268435456-BIT (4194304-WORD BY 64-BIT) DYNAMIC RAM

## Early Write Cycle

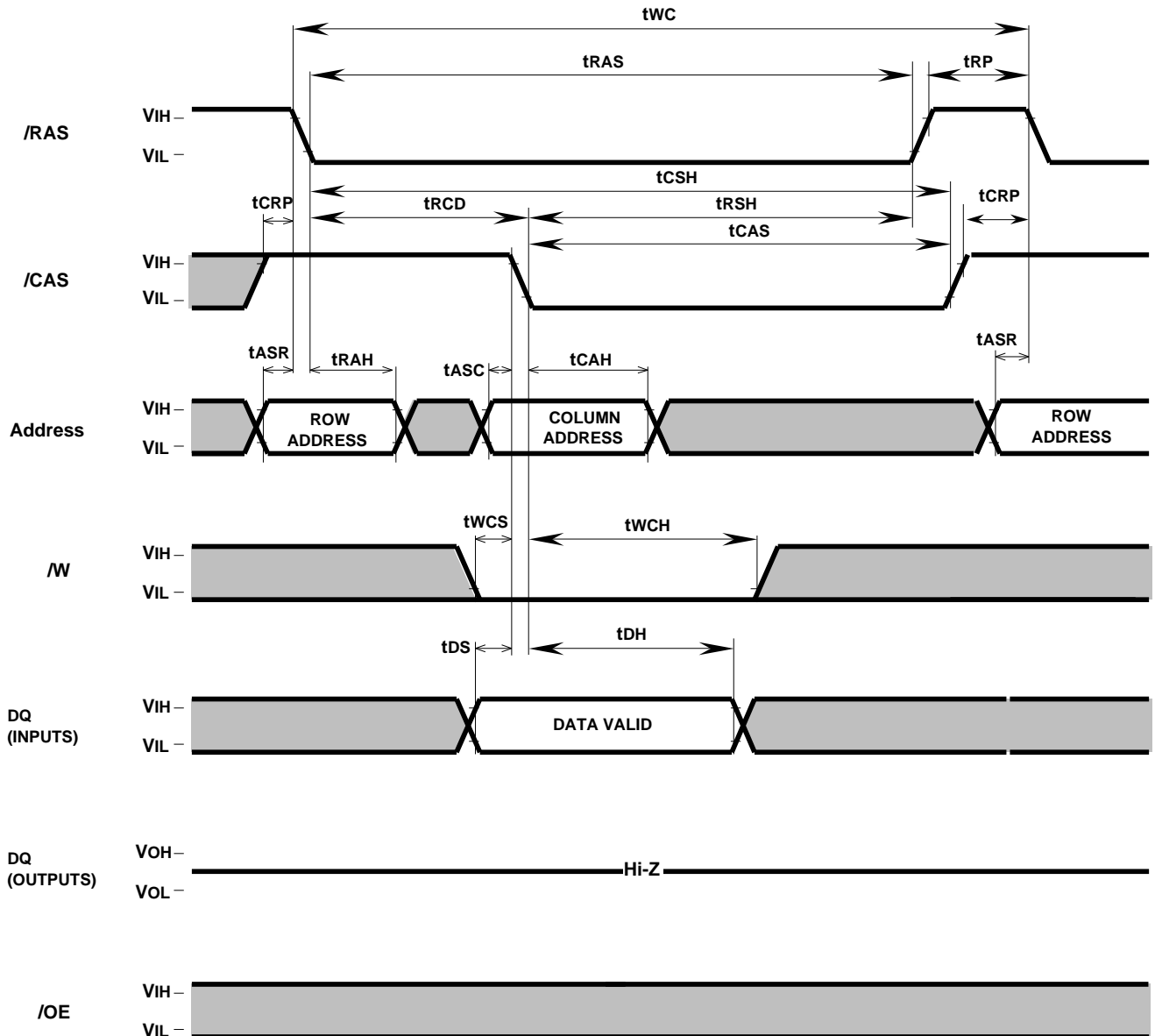



# MH4V6445BXJJ-5,-6,-5S,-6S

HYPER PAGE MODE 268435456-BIT (4194304-WORD BY 64-BIT) DYNAMIC RAM

## Read-Write, Read-Modify-Write Cycle

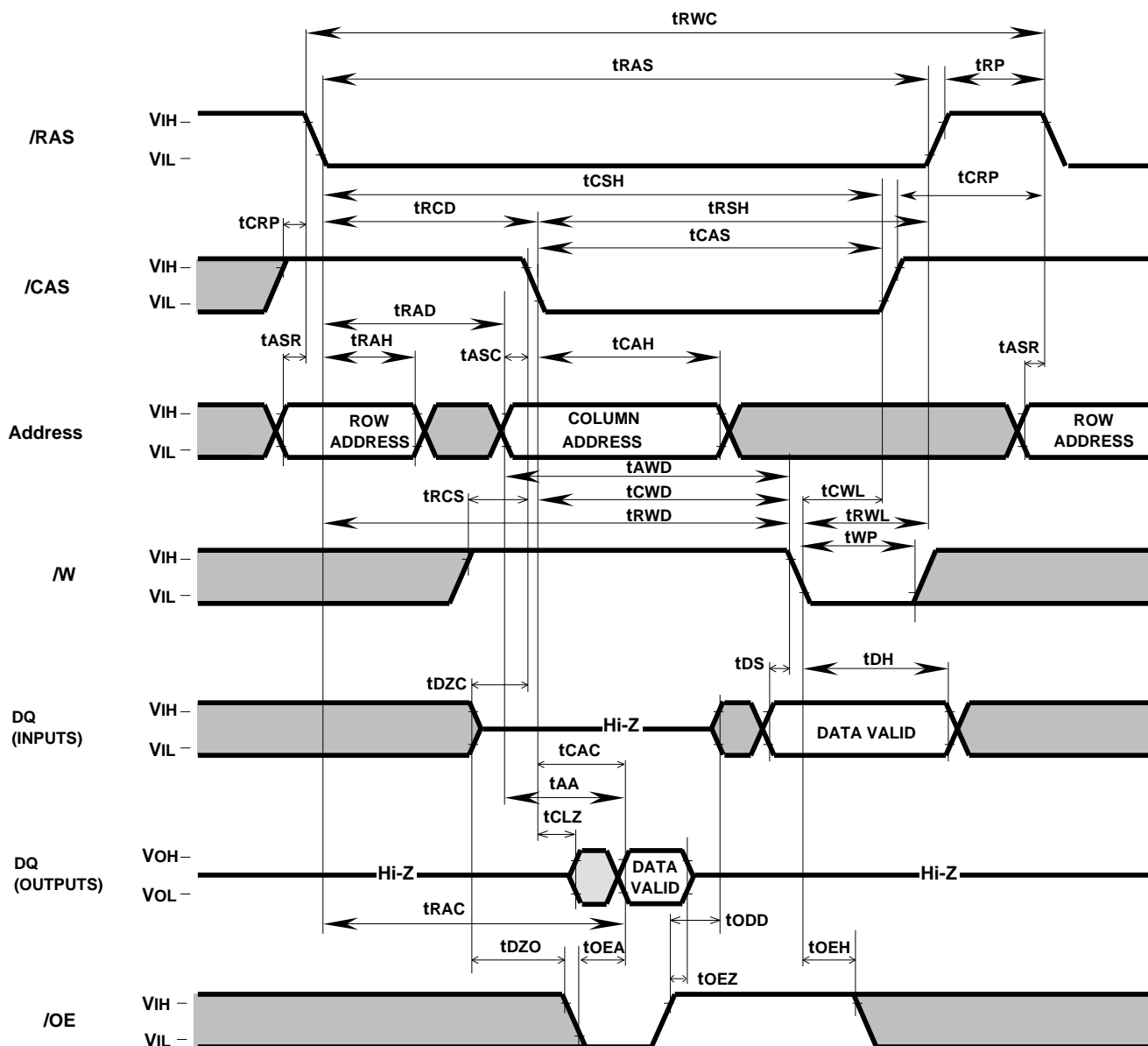

# MH4V6445BXJJ-5,-6,-5S,-6S

HYPER PAGE MODE 268435456-BIT (4194304-WORD BY 64-BIT) DYNAMIC RAM

## Hyper Page Mode Read Cycle

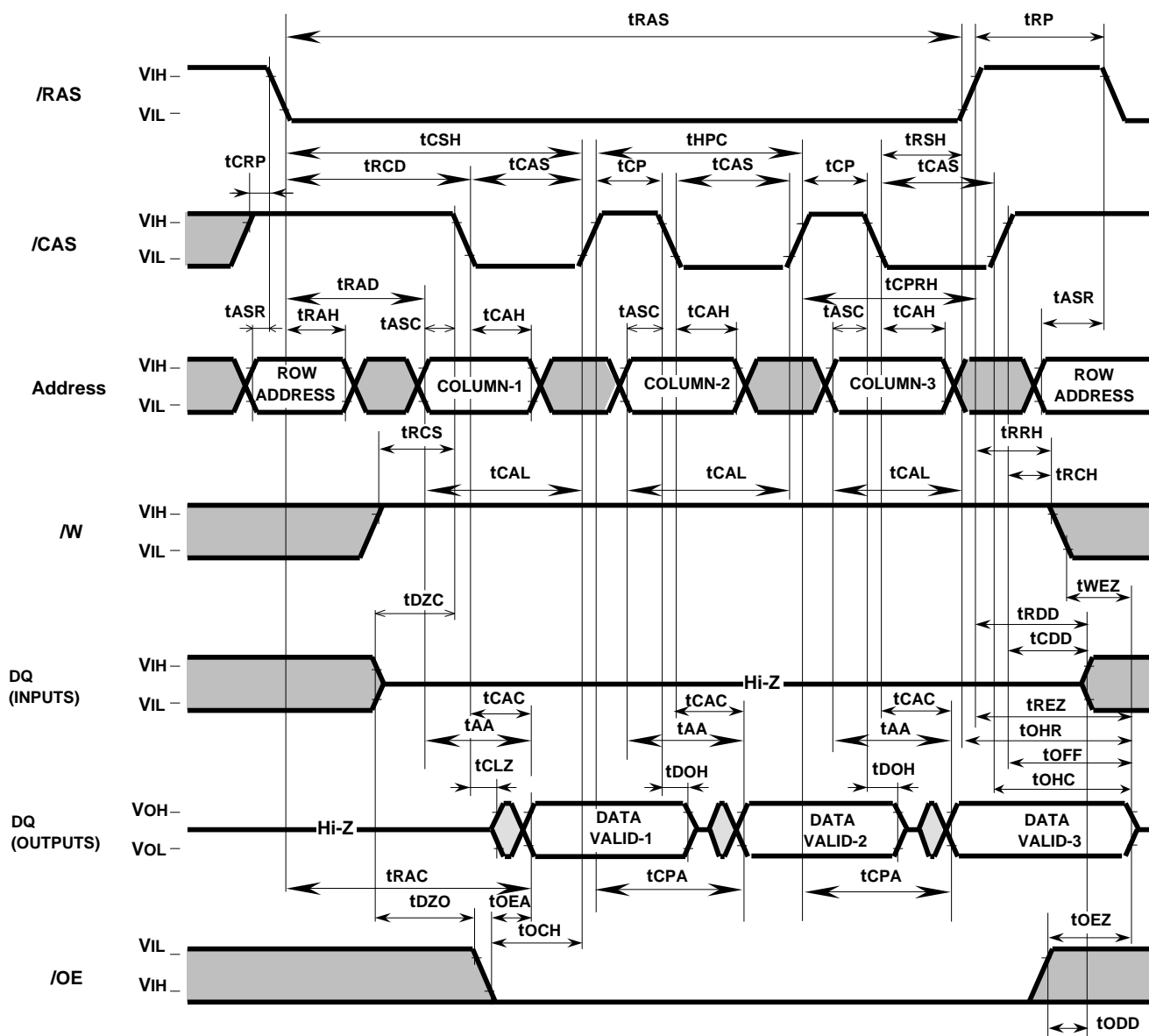

# MH4V6445BXJJ-5,-6,-5S,-6S

HYPER PAGE MODE 268435456-BIT (4194304-WORD BY 64-BIT) DYNAMIC RAM

## Hyper Page Mode Early Write Cycle

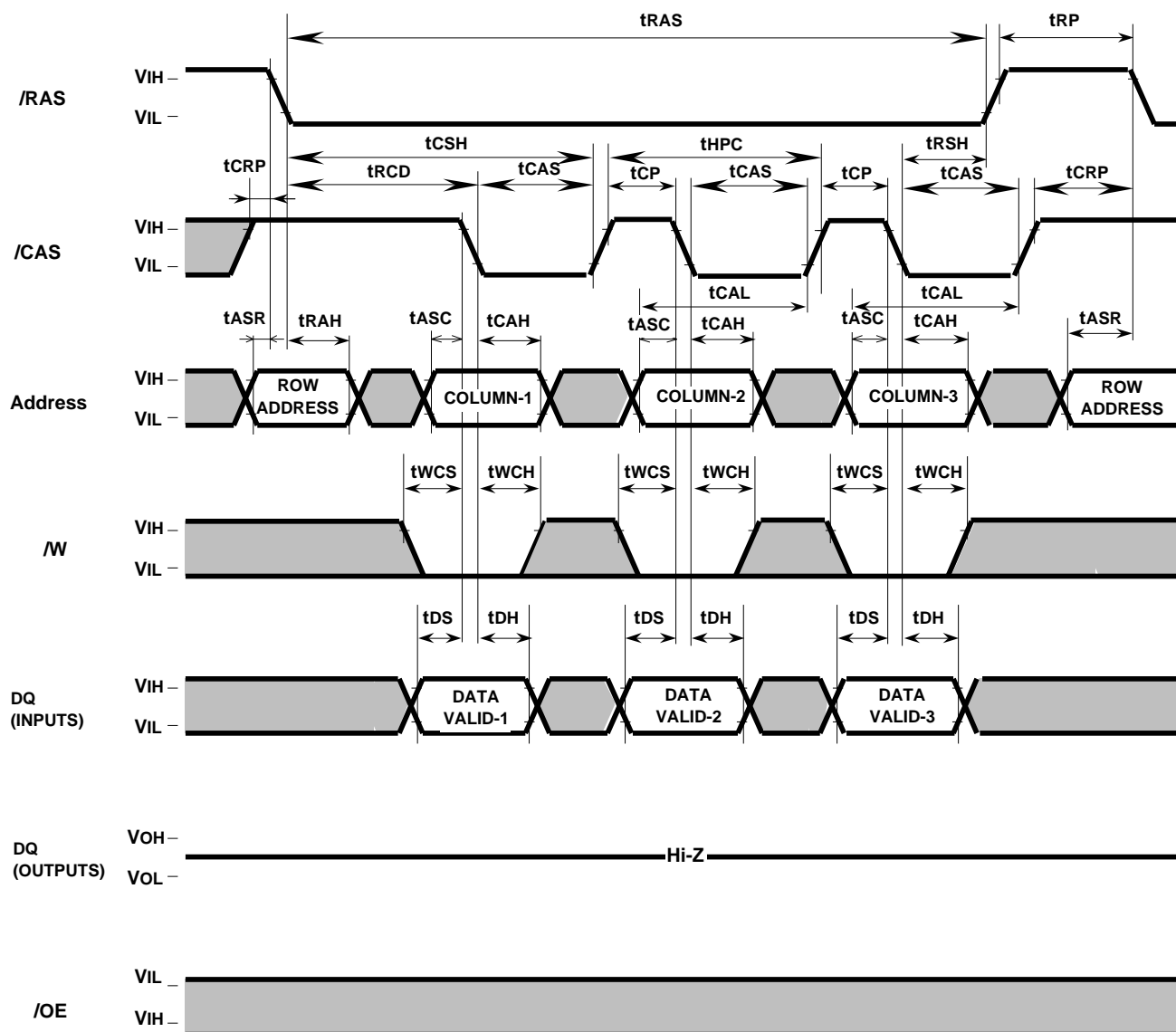





# MH4V6445BXJJ-5,-6,-5S,-6S

HYPER PAGE MODE 268435456-BIT (4194304-WORD BY 64-BIT) DYNAMIC RAM

## Hyper Page Mode Mix Cycle (2)

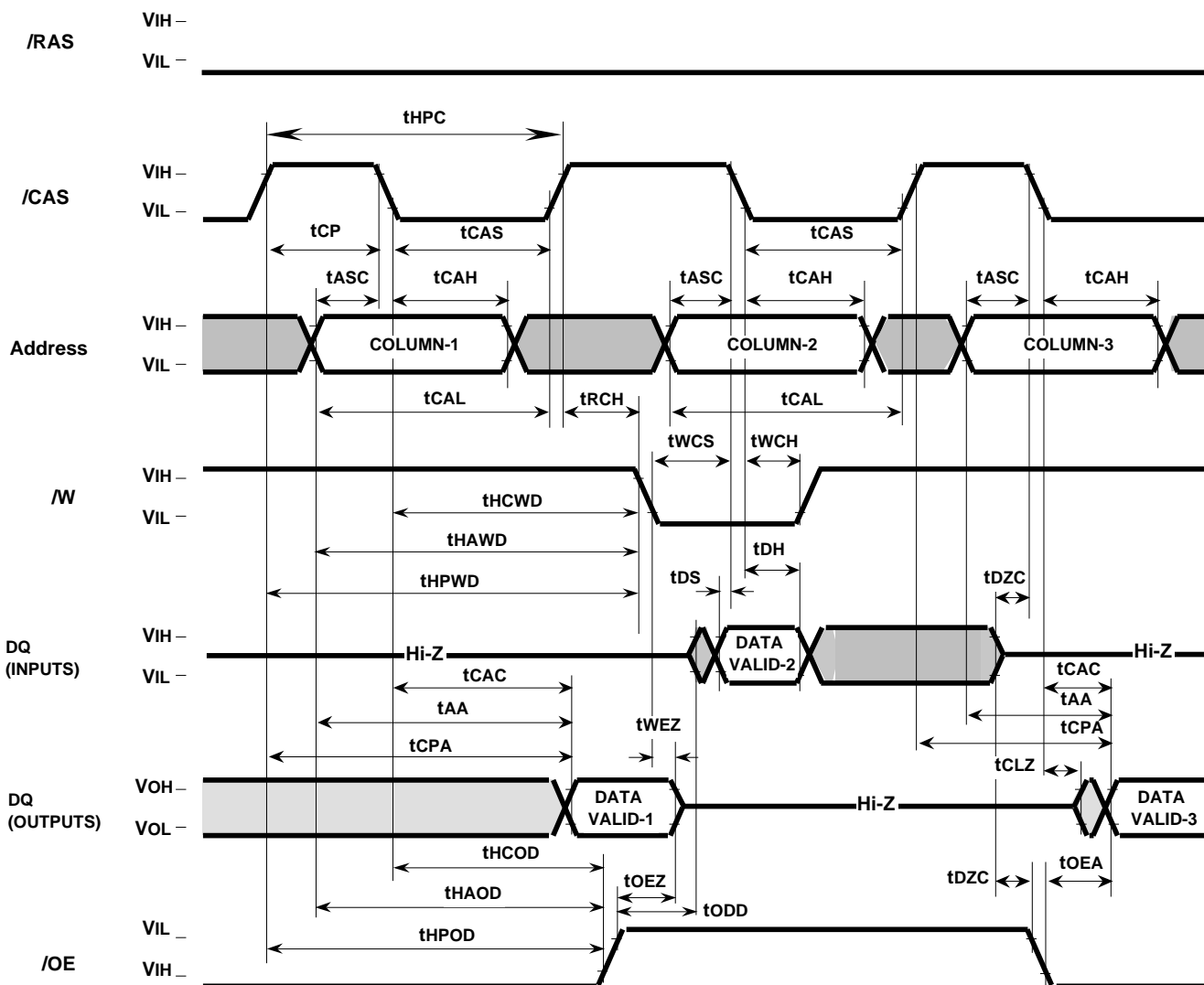

Note30: /OE=L; /W Hi-Z control  
/OE=H; OE Hi-Z control





# MH4V6445BXJJ-5,-6,-5S,-6S

HYPER PAGE MODE 268435456-BIT (4194304-WORD BY 64-BIT) DYNAMIC RAM

## RAS-only Refresh Cycle

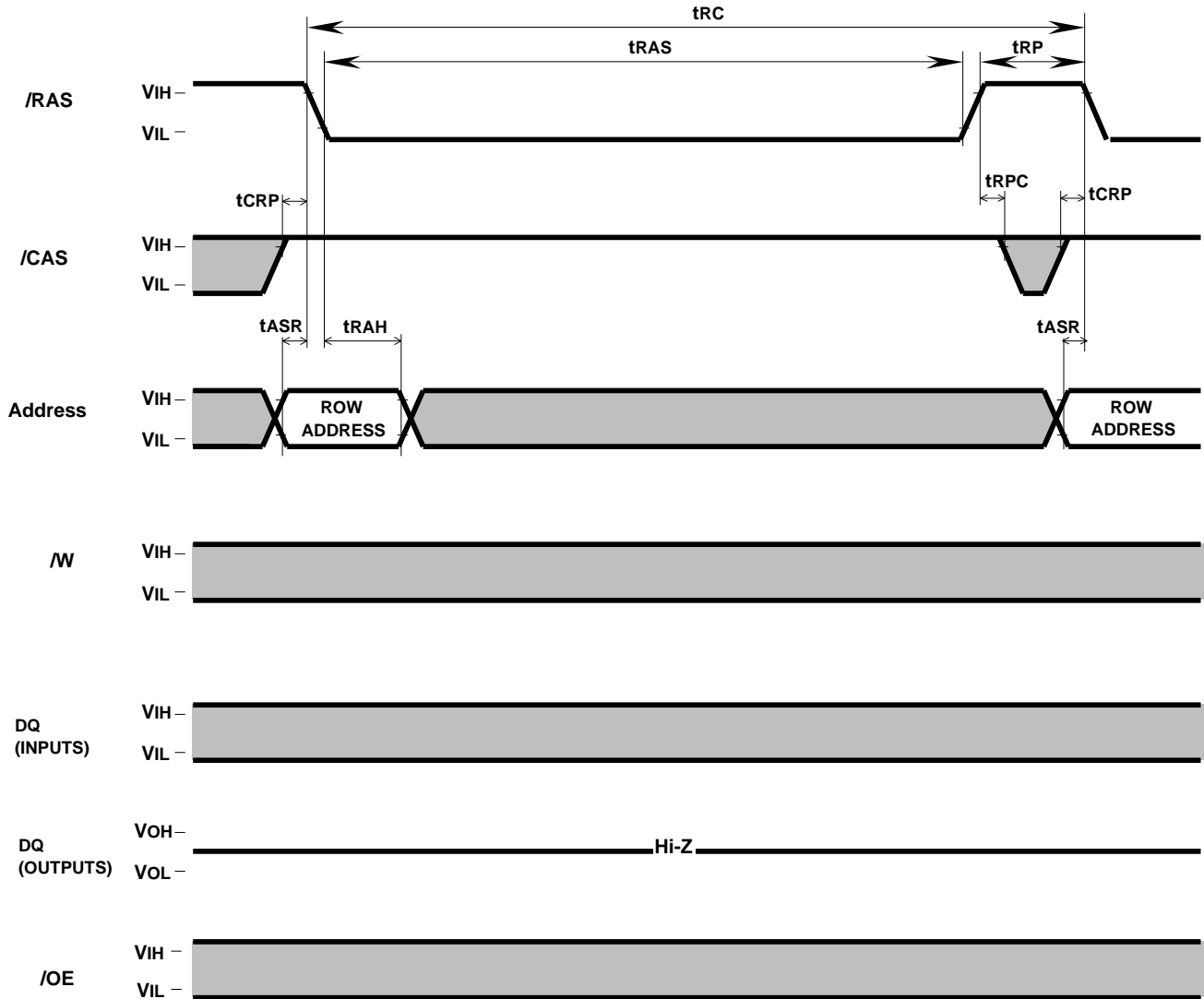

# MH4V6445BXJJ-5,-6,-5S,-6S

HYPER PAGE MODE 268435456-BIT (4194304-WORD BY 64-BIT) DYNAMIC RAM

## /CAS before /RAS Refresh Cycle

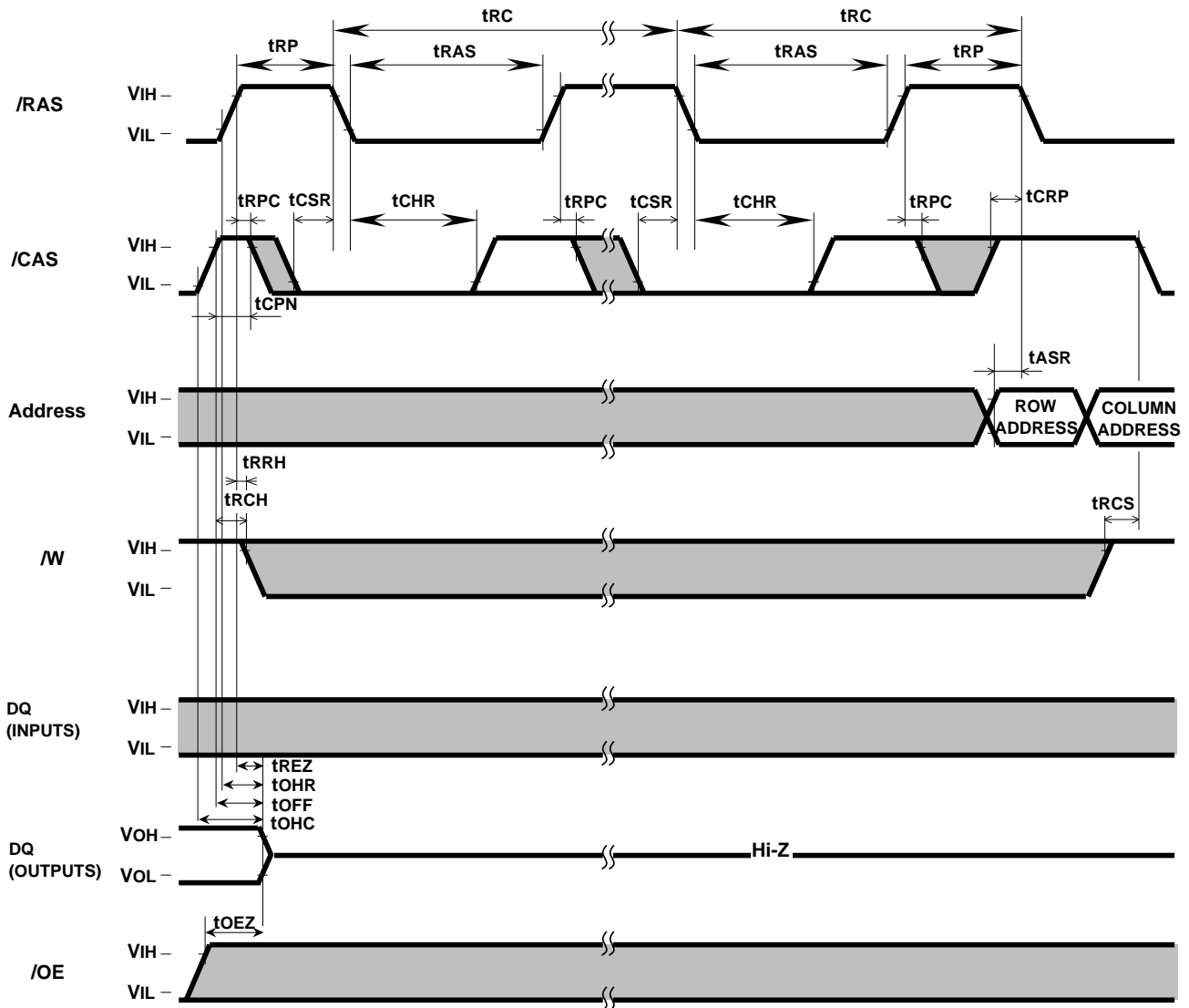

# MH4V6445BXJJ-5,-6,-5S,-6S

HYPER PAGE MODE 268435456-BIT (4194304-WORD BY 64-BIT) DYNAMIC RAM

## Hidden Refresh Cycle (Read) (Note 30)

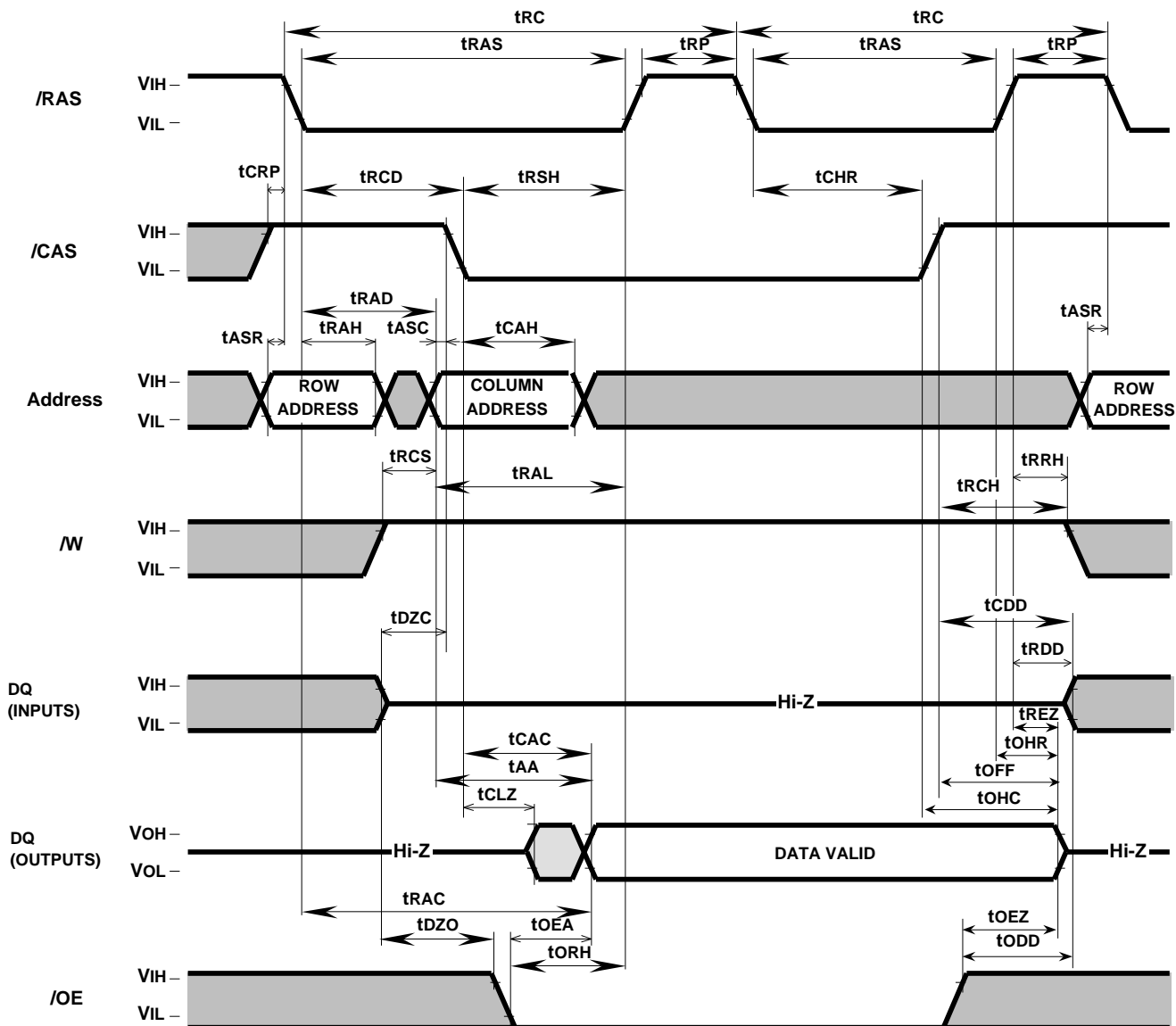

Note 31: Early write, delayed write, read write or read modify write cycle is applicable instead of read cycle. Timing requirements and output state are the same as that of each cycle shown above.

## Self Refresh Cycle

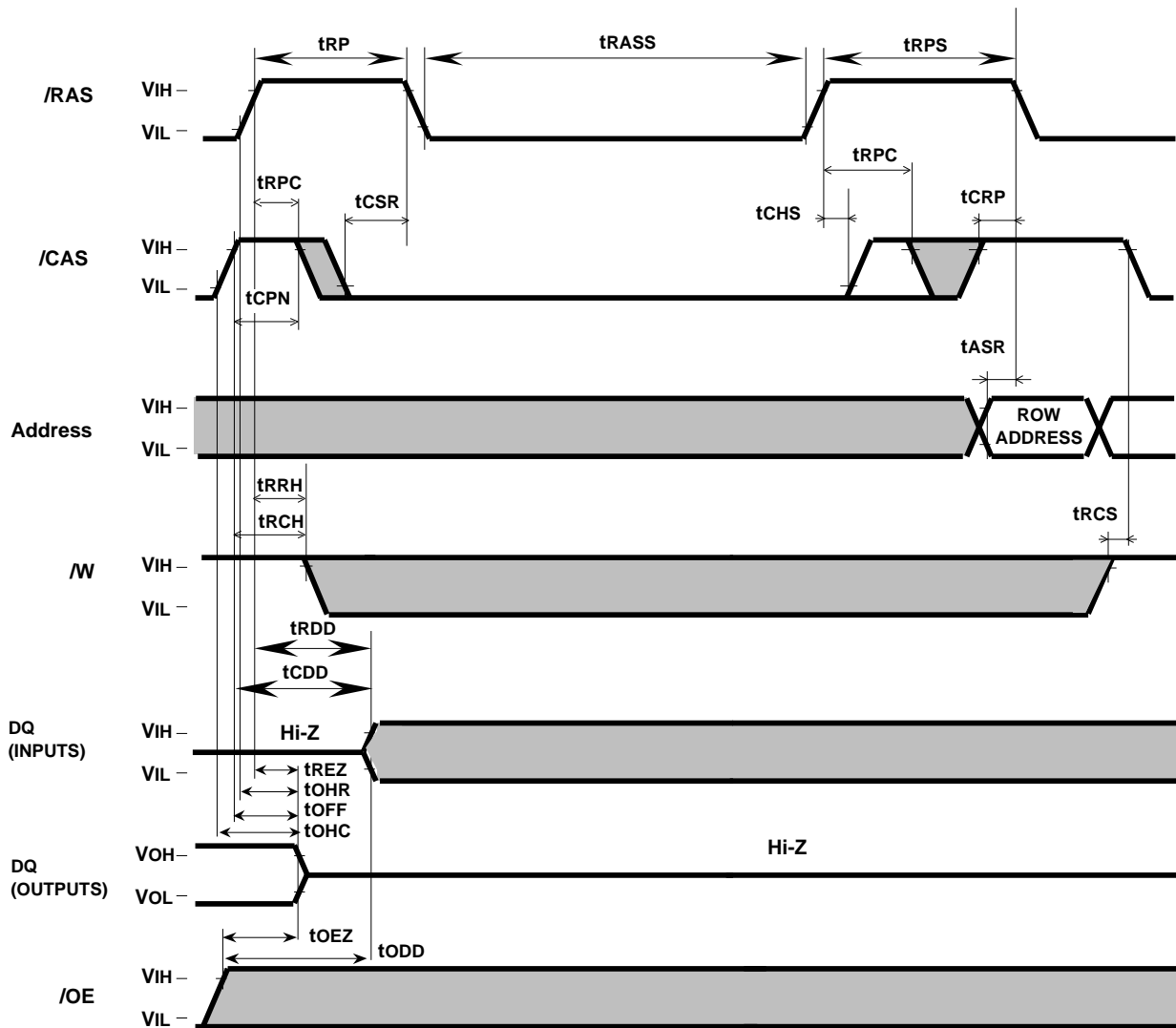



## Keep safety first in your circuit designs!

Mitsubishi Electric Corporation puts the maximum effort into making semiconductor products better and more reliable, but there is always the possibility that trouble may occur with them. Trouble with semiconductors consideration to safety when making your circuit designs, with appropriate measures such as (i) placement of substitutive, auxiliary circuits, (ii) use of non-flammable material or (iii) prevention against any malfunction or mishap.

## Notes regarding these materials

1. These materials are intended as a reference to assist our customers in the selection of the Mitsubishi semiconductor product best suited to the customer's application; they do not convey any license under any intellectual property rights, or any other rights, belonging to Mitsubishi Electric Corporation or a third party.
2. Mitsubishi Electric Corporation assumes no responsibility for any damage, or infringement of any third-party's rights, originating in the use of any product data, diagrams, charts or circuit application examples contained in these materials.
3. All information contained in these materials, including product data, diagrams and charts, represent information on products at the time of publication of these materials, and are subject to change by Mitsubishi Electric Corporation without notice due to product improvements or other reasons. It is therefore recommended that customers contact Mitsubishi Electric Corporation or an authorized Mitsubishi Semiconductor product distributor for the latest product information before purchasing a product listed herein.
4. Mitsubishi Electric Corporation semiconductors are not designed or manufactured for use in a device or system that is used under circumstances in which human life is potentially at stake. Please contact Mitsubishi Electric Corporation or an authorized Mitsubishi Semiconductor product distributor when considering the use of a product contained herein for special applications, such as apparatus or systems for transportation, vehicular, medical, aerospace, nuclear, or undersea repeater use.
5. The prior written approval of Mitsubishi Electric Corporation is necessary to reprint or reproduce in whole or in part these materials.
6. If these products or technologies are subject to the Japanese export control restrictions, they must be exported under a license from the Japanese government and cannot be imported into a country other than the approved destination.  
Any diversion or reexport contrary to the export control laws and regulations of Japan and/or the country of destination is prohibited.
7. Please contact Mitsubishi Electric Corporation or an authorized Mitsubishi Semiconductor product distributor for further details on these materials or the products contained therein.