



DONGGUAN NANJING ELECTRONICS LTD.,

SOD-523 Plastic-Encapsulate Diodes

RB520S-40 Schottky Barrier Diode

FEATURES

- Small surface mounting type
- Low I_R
- High reliability

MARKING: D1

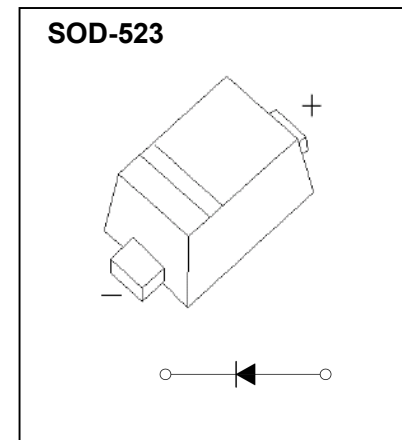

Maximum Ratings and Electrical Characteristics, Single Diode @ $T_A=25^\circ\text{C}$

Parameter	Symbol	Limit	Unit
DC reverse voltage	V_R	40	V
Mean rectifying current	I_0	0.2	A
Peak forward surge current	I_{FSM}	1	A
Power Dissipation	P_D	150	mW
Thermal resistance from junction to ambient	$R_{\theta JA}$	667	$^\circ\text{C}/\text{W}$
Junction temperature	T_J	125	$^\circ\text{C}$
Storage temperature	T_{STG}	-55~+150	

Electrical Ratings @ $T_A=25^\circ\text{C}$

Parameter	Symbol	Min	Typ	Max	Unit	Conditions
Forward voltage	V_F		0.304 0.446	0.39 0.55	V	$I_F=10\text{mA}$ $I_F=100\text{mA}$
Reverse current	I_R		0.605 2.837	1 10	μA	$V_R=10\text{V}$ $V_R=40\text{V}$

Typical Characteristics

RB520S-40

