

Super-mini Signal Conditioners Mini-M Series

THERMOCOUPLE TRANSMITTER

Functions & Features

- Accepts direct input from a thermocouple and provides a standard process signal
- 5-segment linearization
- Burnout
- High-accuracy cold junction compensation
- Fast response type available

Typical Applications

- High-accuracy cold junction compensation benefits narrow span measurements
- 0.1 μ A burnout sensing enables long distance transmission with minimum offset drifts
- Electric furnace (isolation ensured even when 200 V AC power for heater leaks through furnace wall)
- No burnout type can connect to a single T/C in parallel with a recorder

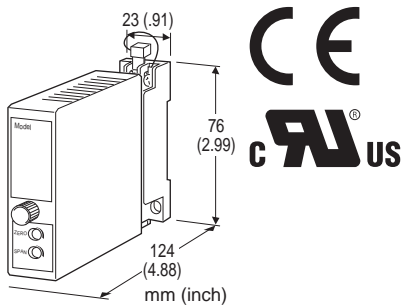

MODEL: M2TS-[1][2]-[3][4]

ORDERING INFORMATION

- Code number: M2TS-[1][2]-[3][4]
Specify a code from below for each [1] through [4].
(e.g. M2TS-2A-M2/BL/CE/Q)
- Temperature range (e.g. 0 - 800°C)
- Special output range (For codes Z & 0)
- Specify the specification for option code /Q
(e.g. /C01/V01)

[1] INPUT THERMOCOUPLE

- 1: (PR) (Usable Range 0 to 1760°C, 32 to 3200°F)
- 2: K (CA) (Usable range -270 to +1370°C, -454 to +2498°F)
- 3: E (CRC) (Usable range -270 to +1000°C, -454 to +1832°F)
- 4: J (IC) (Usable range -210 to +1200°C, -346 to +2192°F)
- 5: T (CC) (Usable range -270 to +400°C, -454 to +752°F)
- 6: B (RH) (Usable range 0 to 1820°C, 32 to 3308°F)
- 7: R (Usable range -50 to +1760°C, -58 to +3200°F)

- 8: S (Usable range -50 to +1760°C, -58 to +3200°F)
- N: N (Usable range -270 to +1300°C, -454 to +2372°F)
- 0: Specify

[2] OUTPUT

Current

- A: 4 - 20 mA DC (Load resistance 750 Ω max.)
- B: 2 - 10 mA DC (Load resistance 1500 Ω max.)
- C: 1 - 5 mA DC (Load resistance 3000 Ω max.)
- D: 0 - 20 mA DC (Load resistance 750 Ω max.)
- E: 0 - 16 mA DC (Load resistance 900 Ω max.)
- F: 0 - 10 mA DC (Load resistance 1500 Ω max.)
- G: 0 - 1 mA DC (Load resistance 15 k Ω max.)
- Z: Specify current (See OUTPUT SPECIFICATIONS)

Voltage

- 1: 0 - 10 mV DC (Load resistance 10 k Ω min.)
- 2: 0 - 100 mV DC (Load resistance 100 k Ω min.)
- 3: 0 - 1 V DC (Load resistance 1000 Ω min.)
- 4: 0 - 10 V DC (Load resistance 10 k Ω min.)
- 5: 0 - 5 V DC (Load resistance 5000 Ω min.)
- 6: 1 - 5 V DC (Load resistance 5000 Ω min.)
- 0: Specify voltage (See OUTPUT SPECIFICATIONS)

[3] POWER INPUT

AC Power

- M: 85 - 264 V AC (Operational voltage range 85 - 264 V, 47 - 66 Hz)
(Select '/N' for 'Standards & Approvals' code.)
- M2: 100 - 240 V AC (Operational voltage range 85 - 264 V, 47 - 66 Hz)
(90 - 264 V for UL)

DC Power

- R: 24 V DC
(Operational voltage range 24 V \pm 10 %, ripple 10 %p-p max.)
- R2: 11 - 27 V DC
(Operational voltage range 11 - 27 V, ripple 10 %p-p max.)
(Select '/N' for 'Standards & Approvals' code.)
- P: 110 V DC
(Operational voltage range 85 - 150 V, ripple 10 %p-p max.)
(110 V \pm 10 % for UL)

[4] OPTIONS (multiple selections)

Response Time (0 - 90 %)

- blank: Standard (\leq 0.5 sec.)
/K: Fast Response (Approx. 25 msec.)

Burnout

- blank: Upscale burnout
/BL: Downscale burnout
/BN: No burnout

Standards & Approvals (must be specified)

- /N: Without CE or UL

/CE: CE marking

/UL: UL approval, CE marking

Other Options

blank: none

/Q: Option other than the above (specify the specification)

SPECIFICATIONS OF OPTION: Q (multiple selections)

COATING (For the detail, refer to M-System's web site.)

/C01: Silicone coating

/C02: Polyurethane coating

/C03: Rubber coating (UL not available)

ADJUSTMENT

/V01: Multi-turn fine adjustment (UL not available)

/VN: Sealed adjustment holes (UL not available)

TERMINAL SCREW MATERIAL

/S01: Stainless steel (UL not available)

GENERAL SPECIFICATIONS

Construction: Plug-in

Connection: M3 screw terminals (torque 0.8 N·m)

Screw terminal: Chromated steel (standard) or stainless steel

Housing material: Flame-resistant resin (black)

Isolation: Input to output to power

Overrange output: Approx. -10 to +120 % at 1 - 5 V

Zero adjustment: -5 to +5 % (front)

Span adjustment: 95 to 105 % (front)

Burnout: Upscale standard; downscale or no burnout optional

At burnout: Downscale \leq -10 %, Upscale \geq 110 %

Linearization: Standard

Cold junction compensation: CJC sensor attached to the input terminals

INPUT SPECIFICATIONS

Minimum span: 3 mV

Offset: Max. 1.5 times span

Input resistance: 30 k Ω min.

Burnout sensing: 0.1 μ A

MIN. span (in °C)

(PR): min. span 370°C

K (CA): min. span 75°C

E (CRC): min. span 50°C

J (IC): min. span 60°C

T (CC): min. span 75°C

B (RH): min. span 780°C

R: min. span 360°C

S: min. span 380°C

N: min. span 110°C

MIN. span (in °F)

(PR): min. span 670°F

K (CA): min. span 140°F

E (CRC): min. span 90°F

J (IC): min. span 110°F

T (CC): min. span 140°F

B (RH): min. span 1410°F

R: min. span 650°F

S: min. span 690°F

N: min. span 200°F

Remark: The described accuracy may be partially not satisfied when the temperature ranges below 0°C. Consult factory.

OUTPUT SPECIFICATIONS

■ **DC Current:** 0 - 20 mA DC

Minimum span: 1 mA

Offset: Max. 1.5 times span

Load resistance: Output drive 15 V max.

■ **DC Voltage:** -10 - +12 V DC

Minimum span: 5 mV

Offset: Max. 1.5 times span

Load resistance: Output drive 1 mA max.; at \geq 0.5 V

INSTALLATION

Power Consumption

•AC:

Approx. 3 VA at 100 V

Approx. 4 VA at 200 V

Approx. 5 VA at 264 V

•DC: Approx. 3 W

Operating temperature: -5 to +55°C (23 to 131°F)

Operating humidity: 30 to 90 %RH (non-condensing)

Mounting: Surface or DIN rail

Weight: 150 g (0.33 lb)

PERFORMANCE in percentage of span

Accuracy: ± 0.4 % (at over 400°C or 750°F for R, S and PR; over 770°C or 1420°F for B)

Cold junction compensation error

(at 25°C ± 10 °C or 77°F ± 18 °F)

K, E, J, T & N: ± 0.5 °C or ± 0.9 °F

S, R & PR: ± 1 °C or ± 1.8 °F

Temp. coefficient: ± 0.015 %/°C (± 0.008 %/°F)

(at over 770°C or 1420°F for B)

Burnout response: ≤ 10 sec.

Line voltage effect: ± 0.1 % over voltage range

Insulation resistance: ≥ 100 M Ω with 500 V DC

Dielectric strength: 2000 V AC @1 minute (input to output to power to ground)

STANDARDS & APPROVALS

EU conformity:
 EMC Directive
 EMI EN 61000-6-4
 EMS EN 61000-6-2
 Low Voltage Directive
 EN 61010-1
 Installation Category II
 Pollution Degree 2
 Input or output to power: Reinforced insulation (300 V)
 Input to output: Basic insulation (300 V)
 RoHS Directive
 EN 50581

Approval:
 UL/C-UL nonincendive Class I, Division 2,
 Groups A, B, C, and D
 (ANSI/ISA-12.12.01, CAN/CSA-C22.2 No.213)
 UL/C-UL general safety requirements
 (UL 61010-1, CAN/CSA-C22.2 No.61010-1)

EXTERNAL DIMENSIONS unit: mm (inch)

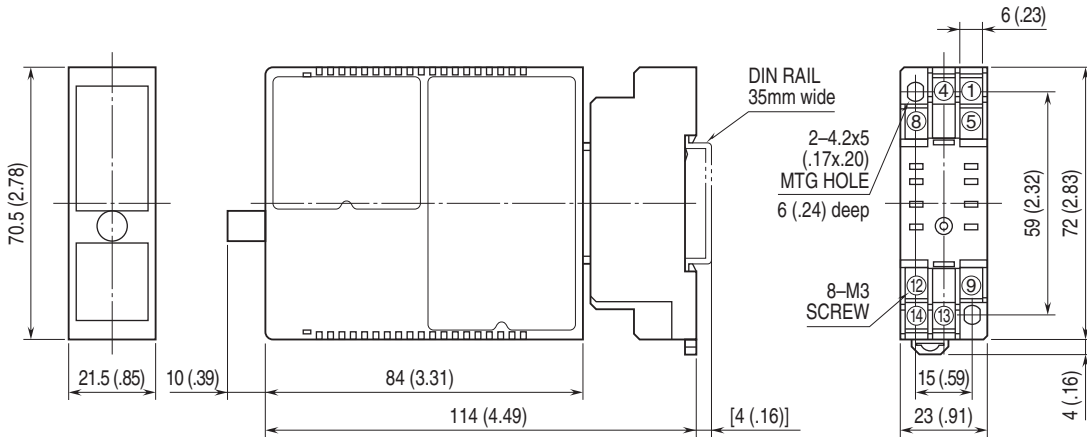

• When mounting, no extra space is needed between units.

TERMINAL ASSIGNMENTS unit: mm (inch)

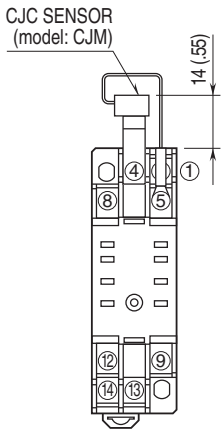

SCHEMATIC CIRCUITRY & CONNECTION DIAGRAM

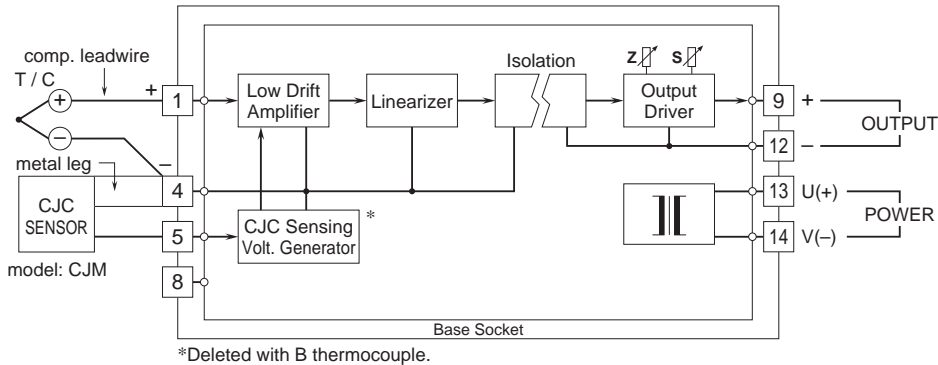

Specifications are subject to change without notice.