



LED760/940-04A



TECHNICAL DATA

Dual LED, 5 mm

AlGaAs, GaAs

Dual LED of LED760/940-04A consists of DDH AlGaAs and GaAs LEDs mounted on a lead frame with a clear epoxy lens.

On forward bias it emits a band of visible light, which peaks 760nm and 940 at anode common.

Specifications

- Structure: AlGaAs (DDH structure)
- Peak Wavelength: typ. 760 nm / 940 nm
- Optical Output Power: typ. 15 mW / 14 mW
- Resin Material: Epoxy resin
- Solder: Lead free

Absolute Maximum Ratings ($T_a=25^\circ\text{C}$)

Item	Symbol	Value		Unit
		760nm	940nm	
Power Dissipation	P_D	200	140	mW
Forward Current	I_F	100		mA
Reverse Voltage	V_R	10		V
Operating Temperature	T_{opr}	-30 ... +80		$^\circ\text{C}$
Storage Temperature	T_{stg}	-30 ... +100		$^\circ\text{C}$
Soldering Temperature *	T_{sol}	265		$^\circ\text{C}$

* must be completed within 3 seconds

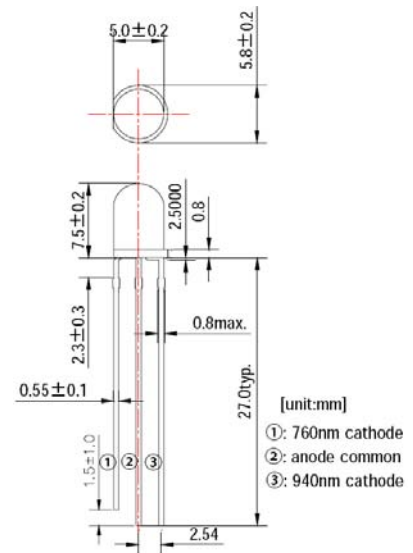

(Unit: mm)

Electro-Optical Characteristics

Item	Symbol	Condition	Min.		Typ.		Max.		Unit
			760nm	940nm	760nm	940nm	760nm	940nm	
Forward Voltage	V_F	$I_F = 20 \text{ mA}$	-	-	1.85	1.30	2.00	1.45	V
Reverse Current	I_R	$V_R = 5 \text{ V}$	-	-	-	-	10	-	μA
Total Radiated Power	P_O	$I_F = 20 \text{ mA}$	8.0	8.0	15.0	14.0	-	-	mW
Peak Wavelength	λ_P	$I_F = 20 \text{ mA}$	740	930	760	940	780	960	nm
Half Width	$\Delta\lambda$	$I_F = 20 \text{ mA}$	-	-	30	50	-	-	nm
Viewing Half Angle	$\Theta_{1/2}$	$I_F = 20 \text{ mA}$	-	-	± 20		-	-	deg.

Total Radiated Power is measured by Photodyne #500

Notes

- Do not view directly into the emitting area of the LED during operation!
- The above specifications are for reference purpose only and subjected to change without prior notice.





Precaution for Use

1. Cautions

- DO NOT look directly into the emitted light or look through the optical system. To prevent in adequate exposure of the radiation, wear protective glasses.

2. Lead Forming

- When forming leads, the leads should be bent at a point at least 3 mm from the base of the lead. DO NOT use the base of the leadframe as a fulcrum during lead forming.
- Lead forming should be done before soldering.
- DO NOT apply any bending stress to the base of the lead. The stress to the base may damage the LED's characteristics or it may break the LEDs.
- When mounted the LEDs onto the printed circuit board, the holes on the circuit board should be exactly aligned with the leads of LEDs. If the LEDs are mounted with stress at the leads, it causes deterioration of the lead and it will degrade the LEDs.

Recommended Land Layout (Unit: mm)

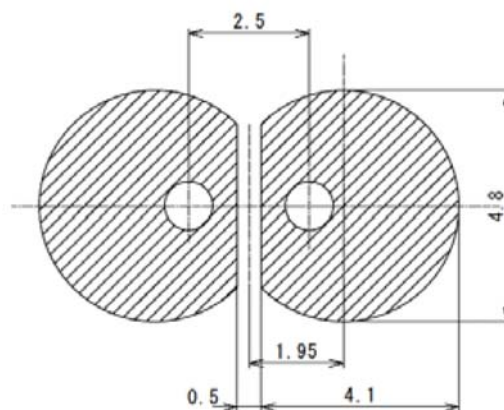

3. Soldering Conditions

- Solder the LEDs no closer than 3 mm from the base of the lead.
- DO NOT apply any stress to the lead particularly when heat.
- The LEDs must not be reposition after soldering.
- After soldering the LEDs, the lead should be protected from mechanical shock or vibration until the LEDs return to room temperature.
- When it is necessary to clamp the LEDs to prevent soldering failure, it is important to minimize the mechanical stress on the LEDs.
- Cut the LED leads at room temperature. Cutting the leads at high temperature may cause the failure of the LEDs.

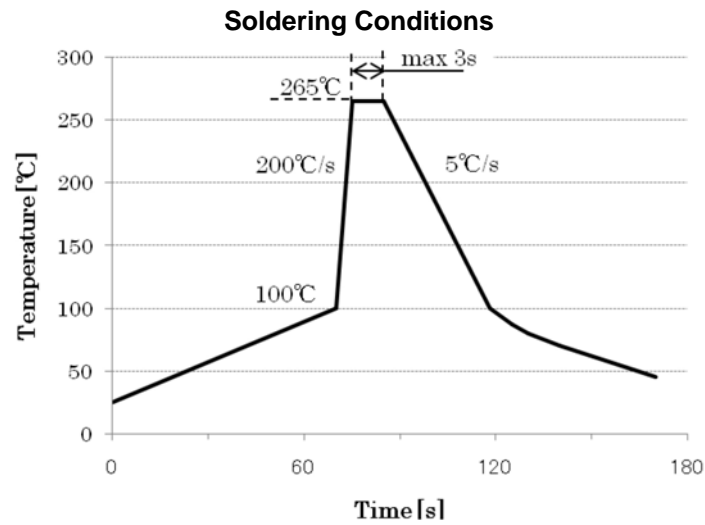

4. Static Electricity

- The LEDs are very sensitive to Static Electricity and surge voltage. So it is recommended that a wrist band or an anti-electrostatic glove be used when handling the LEDs.
- All devices, equipment and machinery must be grounded properly. It is recommended that precautions should be taken against surge voltage to the equipment that mounts the LEDs.