

## Cable connector - RC-16S1N12T0EM - 1601016

Please be informed that the data shown in this PDF Document is generated from our Online Catalog. Please find the complete data in the user's documentation. Our General Terms of Use for Downloads are valid (<http://phoenixcontact.com/download>)

Cable connector, angled, shielded: yes, Screw locking, M23, No. of pos.: 16, type of contact: Socket, Solder connection, cable diameter range: 3 mm ... 10.5 mm



The figure shows the 12-pos. product version



### Key Commercial Data

Packing unit	8 pc
GTIN	 4 046356 697613
GTIN	4046356697613

### Technical data

#### Environmental Product Compliance

REACH SVHC	Lead 7439-92-1
China RoHS	Environmentally Friendly Use Period = 50
	For details about hazardous substances go to tab "Downloads", Category "Manufacturer's declaration"

### Drawings

# Cable connector - RC-16S1N12T0EM - 1601016

Schematic diagram

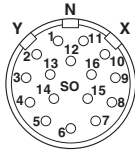

Dimensional drawing

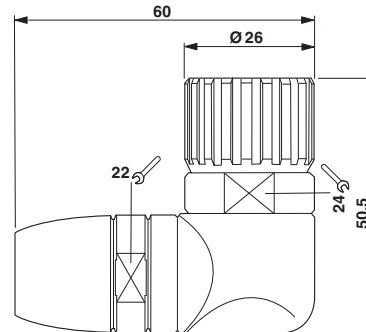

## Approvals

Approvals

---

Approvals

EAC

---

Ex Approvals

---

Approval details

EAC		B.01742
-----	--	---------



---

Phoenix Contact 2018 © - all rights reserved  
<http://www.phoenixcontact.com>

PHOENIX CONTACT GmbH & Co. KG  
Flachsmarktstr. 8  
32825 Blomberg  
Germany  
Tel. +49 5235 300  
Fax +49 5235 3 41200  
<http://www.phoenixcontact.com>