

ADSL Magnetics

For Analog Devices AD20MSP930

- Designed to meet IEC 950 safety requirements for supplementary insulation at 250V
- Minimum interwinding breakdown voltage of 1500 Vrms
- Complies with all of the requirements in the transformer specification generated by Analog Devices
- Operating temperature range: -40° C to +85° C
- Meets IEC 695, 2-2 flammability requirements
- PWB Process Capability: standard printed wiring board assembly techniques, total-immersion cleaning
- Reliability testing: shock, vibration, temperature cycling, temperature - humidity - bias

ELECTRICAL SPECIFICATIONS AT 25° C

Part Number	Application	Package	Turns Ratio ±2%	Inductance	Leakage Inductance µH max	DCR Ω max		Longitudinal Balance dB min	Insertion Loss dB max	Frequency Response dB	Harmonic Distortion dB max
			Chip : Line	Chip Side	Chip Side	Chip Side	Line Side	10 kHz - 1.1 MHz	300 kHz	30 kHz - 1.1 MHz	
S560-6600-F3	ADSL over ISDN - CO	SMD	1 : 1	100 µH ±7% ¹	4	1	1	46	0.5	± 0.5	-80 ³
0560-6600-E4		THT									
S560-6600-F4	ADSL over ISDN - CPE	SMD	1 : 1.2	120 µH ±10% ¹	4	0.61	0.74	46	0.5	± 0.5	-80 ³
0560-6600-E5		THT									
S560-6600-F5	ADSL over POTS - CO	SMD	1 : 1.1	2 mH ±10% ²	8.5	1.7	1.8	46	0.5	± 0.5	-80 ⁴
0560-6600-E6		THT									
S560-6600-F6	ADSL over POTS - CPE	SMD	1 : 1.1	1.2 mH ±10% ²	10	1.25	1.4	46	0.5	± 0.5	-80 ⁴
0560-6600-E7		THT									

All measurements are made with pins 2 and 3 connected and pins 8 and 9 connected

1. measured at 100 kHz, 1 Vac

2. measured at 20 kHz, 1 Vac

3. measured with 100 Ω source at 100 kHz, 4 Vac

4. measured with 100 Ω source at 20 kHz, 4 Vac

SCHEMATIC

S560-6600-F3 **0560-6600-E4**
S560-6600-F4 **0560-6600-E5**
S560-6600-F5 **0560-6600-E6**
S560-6600-F6 **0560-6600-E7**

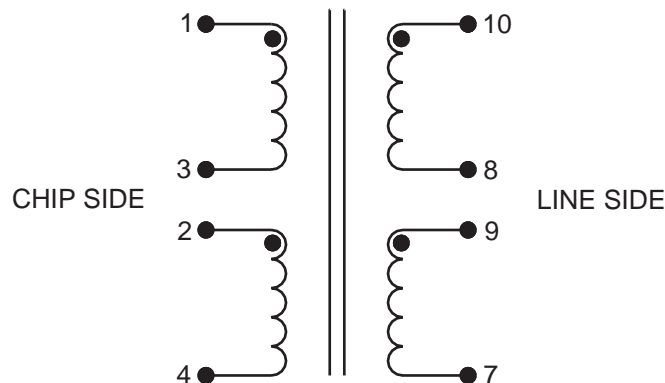

TM00305

MECHANICAL

S560-6600-F3
S560-6600-F4
S560-6600-F5
S560-6600-F6

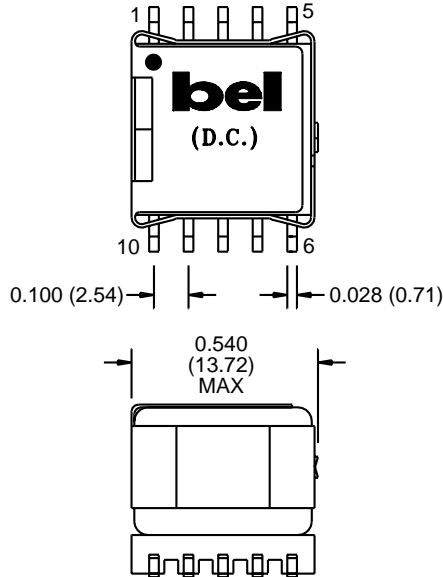

SUGGESTED PCB PAD LAYOUT

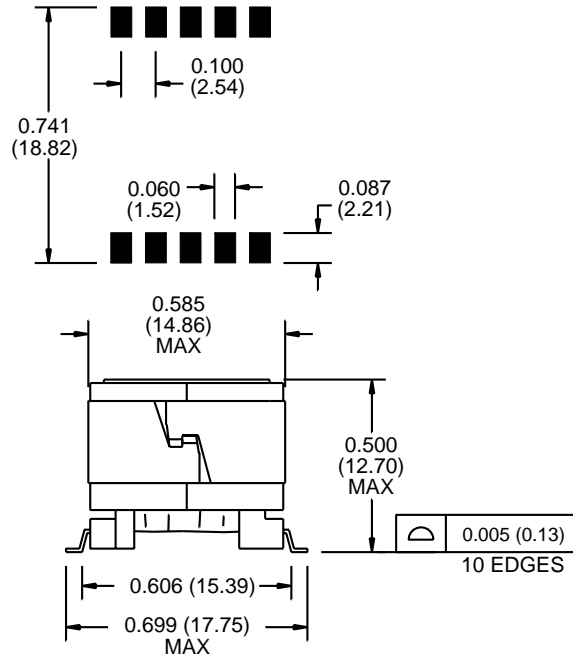

0560-6600-E4
0560-6600-E5
0560-6600-E6
0560-6600-E7

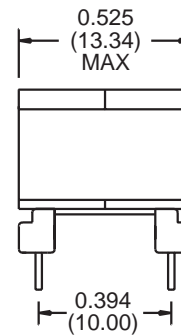
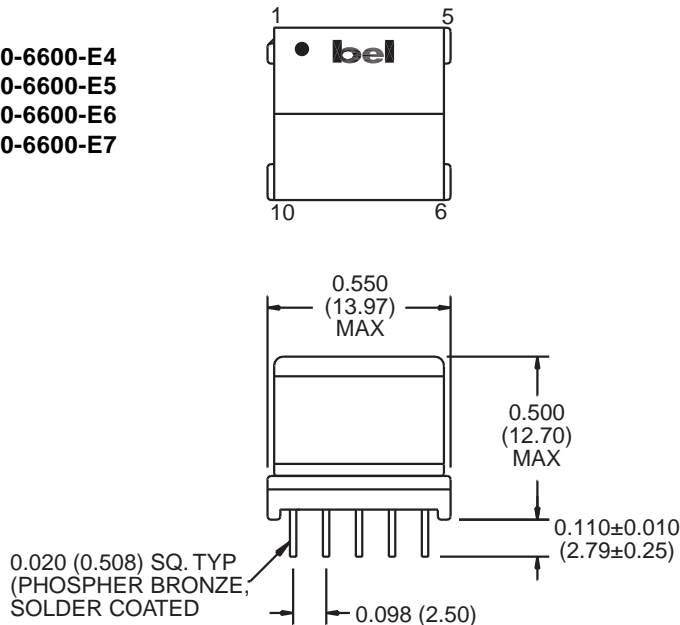

©2000 Bel Fuse Inc. Specifications subject to change without notice. 06.00

CORPORATE

Bel Fuse Inc.
198 Van Vorst Street
Jersey City, NJ 07302
Tel 201-432-0463
Fax 201-432-9542
www.belfuse.com

FAR EAST

Bel Fuse Ltd.
8F / 8 Luk Hop Street
San Po Kong
Kowloon, Hong Kong
Tel 852-2328-5515
Fax 852-2352-3706
www.belfuse.com

EUROPE

Bel Fuse Europe Ltd.
Preston Technology Management Centre
Marsh Lane, Suite G7, Preston
Lancashire, PR1 8UD, U.K.
Tel 44-1772-556601
Fax 44-1772-888366
www.belfuse.com