



-  Compliant with IEEE802.3 standard including 350uH OCL with 8mA DC Bias
-  Operating temperature 0°C to +70°C
-  RoHS compliant



ELECTRICAL SPECIFICATION @ 25°C

Part Number	PoE	Insertion Loss (dB Max)	Return Loss (dB Min)				CMRR (dB Min)			Crosstalk (dB Min)			Hipot (Vrms)
			0.1-100MHz	1-30MHz	40MHz	50MHz	60-80MHz	1-60MHz	60-200MHz	1MHz	30MHz	60MHz	
824-C0256F	No	1.0	18	14.4	13.1	12	37	25	55	45	40	33	1500
824-00428F	Yes	1.2	18	15.5	13.6	12	33			33			1500
824-00429R ¹	Yes	1.2	16	14	13	12	40	35	30	43	37	33	1500

Notes: 1. CMRR is only for TX channels.

ELECTRICAL SPECIFICATION @ 25°C

Part Number	PoE	Insertion Loss (dB Max)	Return Loss (dB Min)				DM-CMRR (dB Min)			Crosstalk (dB Min)			Hipot (Vrms)
			1-100MHz	1-30MHz	40MHz	50MHz	60-80MHz	30MHz	60MHz	100MHz	30MHz	60MHz	
824-00417R	Yes	1.2	16	14	13	12	43	37	33	43	37	33	1500

ELECTRICAL SPECIFICATION @ 25°C

Part Number	PoE	Insertion Loss (dB Max)	Return Loss (dB Min)				CMRR (dB Typ)	Crosstalk (dB Typ)	Hipot (Vrms)
			0.1-100MHz	1-30MHz	40MHz	50MHz			
824-00433R	Yes	1.2	18	15.5	13.6	12	40	40	1500

MECHANICAL DIMENSIONS

824-C0256F / 824-00433R

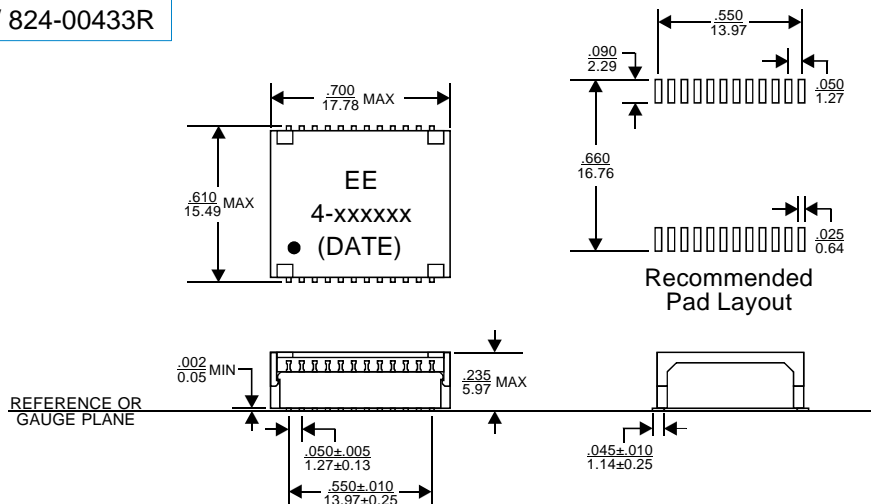



MECHANICAL DIMENSIONS

824-00428F / 824-00429R

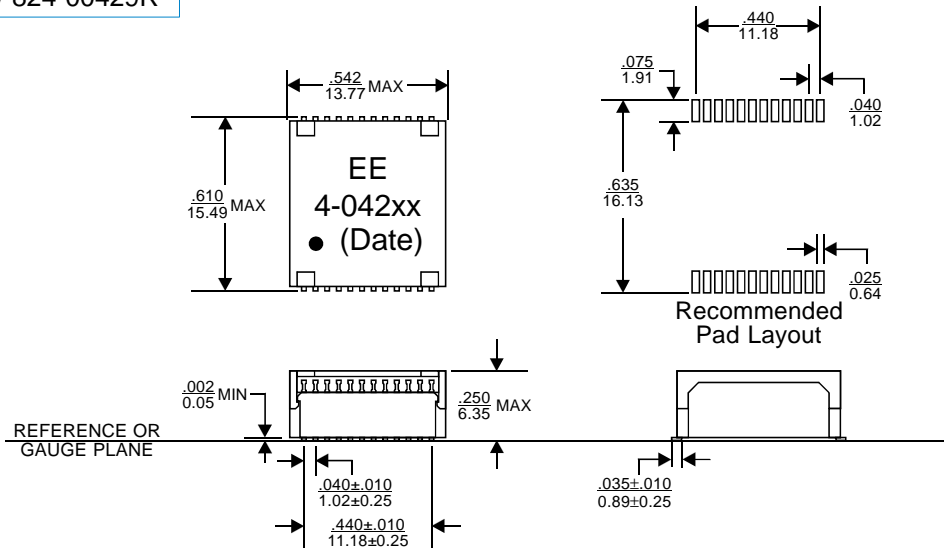

MECHANICAL DIMENSIONS

824-00417R

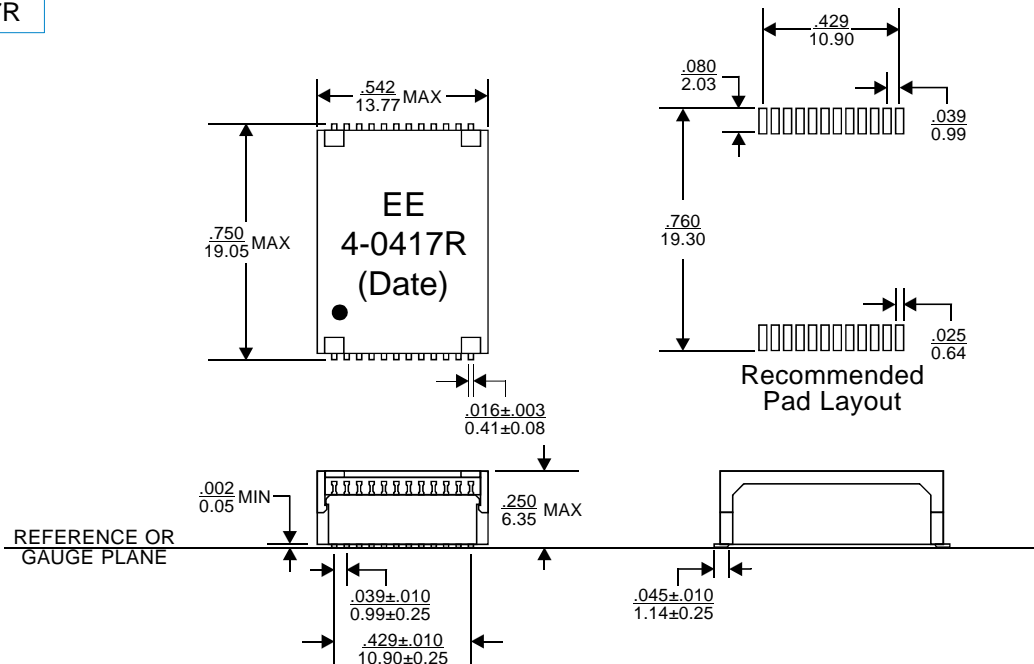

Notes:

2. Dimensions are specified in inches with higher precedence in inches.
mm
3. Unless otherwise specified, all tolerance are $\pm .010$ / 0.25 .
4. Coplanarity: $.004$ / 0.10 max.
5. "(DATE)" includes at least the manufacturing date code (in YYWW format) plus two character country code.
6. When ordering, please add suffix "T" to the part number for tape & reel packaging (330mm reel).

SCHEMATICS

824-C0256F

LINE SIDE (Secondary)

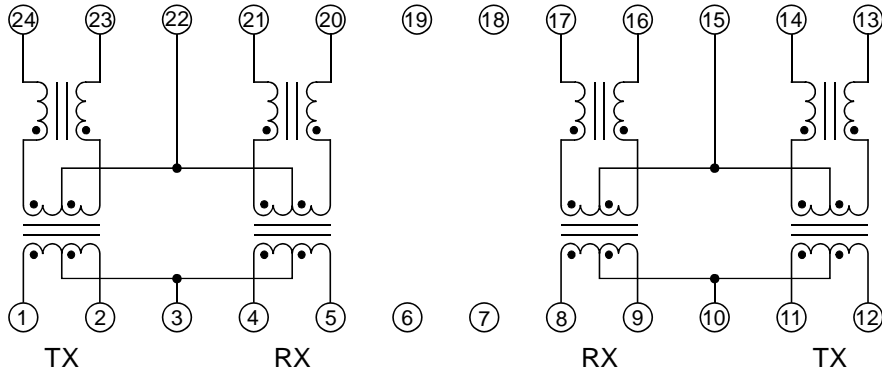

CHIP SIDE (Primary)

SCHEMATICS

824-00428F

LINE SIDE (Secondary)

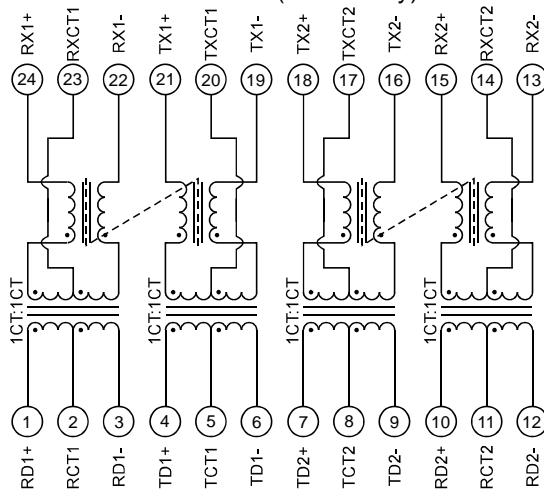

CHIP SIDE (Primary)

SCHEMATICS

824-00429R

LINE SIDE (Secondary)

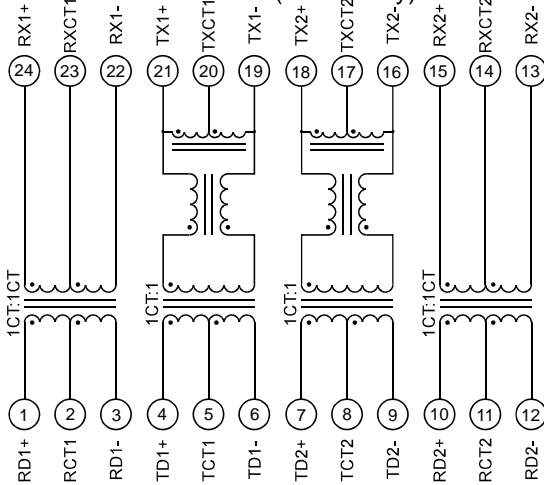

CHIP SIDE (Primary)



SCHEMATICS

824-00433R

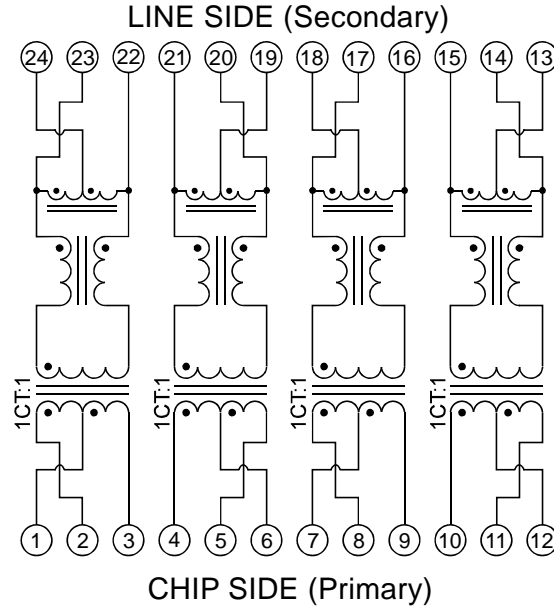

SCHEMATICS

824-00417R

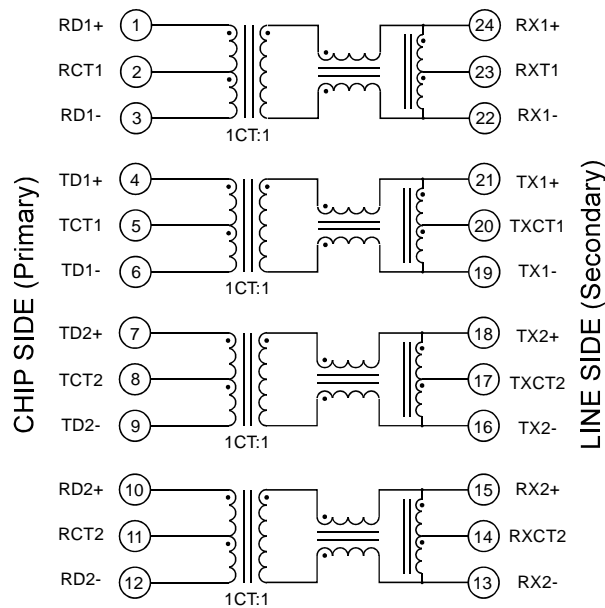

PACKAGING

824-C0256F / 824-00433R

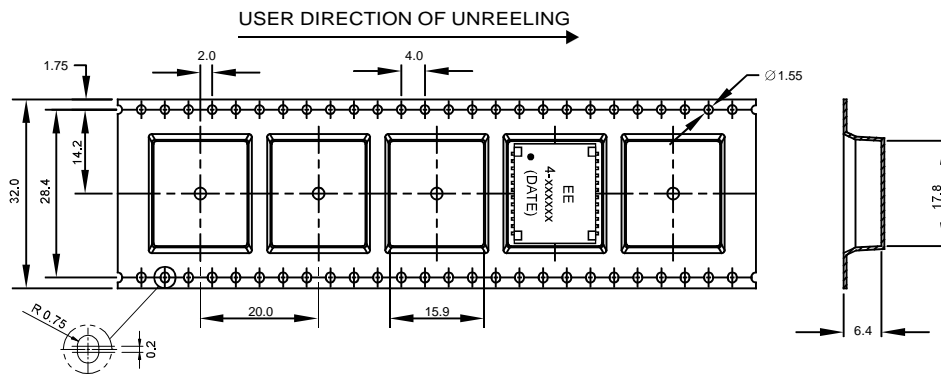

Weight (in gram) : 1.7 typ.
Tape & Reel : 450 / reel

PACKAGING

824-00428F / 824-00429R

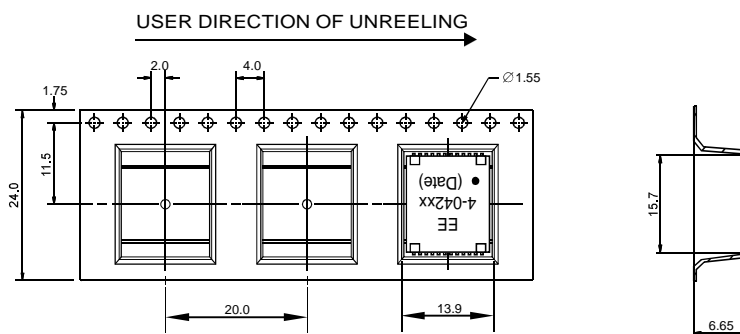

Weight (in gram) : 1.8 typ.
Tape & Reel : 450 / reel

PACKAGING

824-00417R

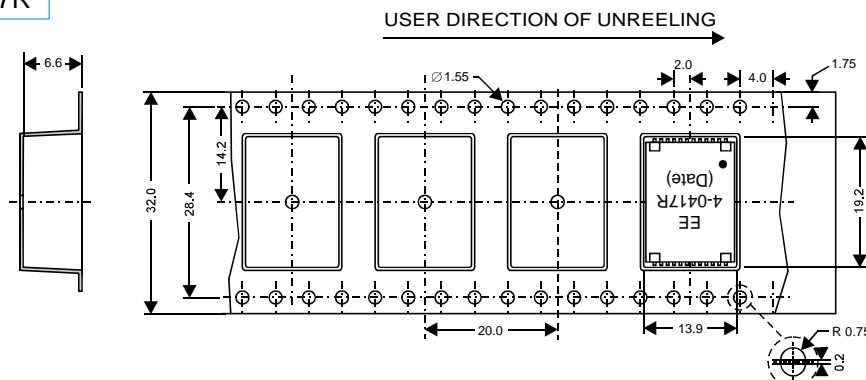

Weight (in gram) : 1.9 typ.
Tape & Reel : 450 / reel

FOR MORE INFORMATION, PLEASE CONTACT

HEADQUARTER
1/F., Harbour View 1, No.12 Science Park East Avenue,
Phase II, Hong Kong Science Park, Shatin, N.T.
Hong Kong
Tel: (852) 2954 3333 Fax: (852) 2954 3304
Email: eempl@eleceltek.com
Website: <http://www.eleceltek.com> / www.eemagnetic.com

Information herein is for reference only and subject to change without notice. It does not constitute any representation, warranty or commitment of the company in respect of the products in any aspect. All logos, brands and product names mentioned herein are trademarks or registered trademarks of their respective owners. The company does not assume any liability arising out of the application or use of any product or circuit described herein. Copyrights 2009, E & E Magnetic Products Limited.

1/F., Harbour View 1, No.12 Science Park East Avenue, Phase II, Hong Kong Science Park, Shatin, N.T. Hong Kong
Tel: (852) 2954 3333 • Fax: (852) 2954 3304