



ACE77LE9

High Efficiency Low Noise PFM Step-Up DC/DC Converter

Description

The ACE77LE9 PFM step-up DC/DC Converter drives white LEDs with a constant current to provide backlight in cell phones, PDAs, and other hand-held devices. It features allowing series connection of the white LEDs so that the LED currents are identical for uniform brightness. An enable input can be pulsed repeatedly to adjust LEDs brightness. The fast 500kHz to 2MHz operation frequency allows for smaller capacitor and inductor. Fault condition protection uses cycle-by-cycle current limiting to sense maximum inductor current and over-voltage protection. The 0.2V low reference voltage minimizes the power loss across the current sense resistor.

The converter can operate from 2V to 6V, and capable of delivering maximum 200mA output current at 4-LEDs application with 3V input voltage. Quiescent current drawn from power source is as low as 120uA. All of these features make ACE77LE9 be suitable for the portable devices, which are supplied by a single battery.

Features

- Up to 24V Output Voltage
- Wide Operation Range: 2V to 6V
- Maximum 2MHz Operating Frequency
- PWM Dimming Control
- Shutdown Current <1μA
- Current Limit Cycle-by-Cycle
- Low Current Sense Threshold: 200mV
- 24V Over Output Voltage Protection
- Compact SOT23-6 Package

Application

- Compact Back Light Module
- Power Source for LED
- Constant Current Source

Absolute Maximum Ratings

Symbol	Parameter	Value	Unit
V_{IN}	Supply Voltage on VIN	-0.3 to 8.0	V
V_{CE}	Voltages on Pin CE	-0.3 to $V_{IN}+0.3$	V
I_{LX}	LX Pin Output Current	1.6	A
V_{LX}	LX Pin Voltage	24	V
P_D	Continuous Power Dissipation	250	mW
T_A	Operating Ambient Temperature	-40 to 85	°C
T_J	Operating Junction Temperature	125	°C
T_{STG}	Storage Temperature Range	-40 to 150	°C
T_L	Maximum Lead Temperature for Soldering 10 Seconds	260	°C



ACE77LE9

High Efficiency Low Noise PFM Step-Up DC/DC Converter

Packaging Type

SOT-23-6

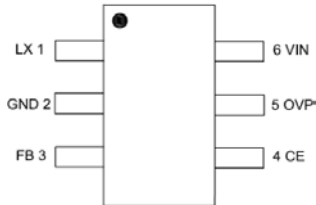

Pin Description

Pin Number	Symbol	Function
1	LX	Switching Pin
2	GND	Ground Pin
3	FB	Pin for Feedback Voltage
4	CE	Chip Enable Pin (Active with "H")
5	OVP	Over Voltage Protection
6	VIN	Power Supply Pin

Ordering Information

ACE77LE9 XX + H

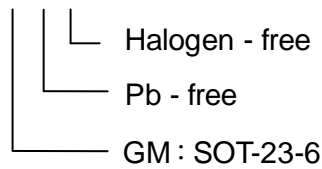

Typical Application

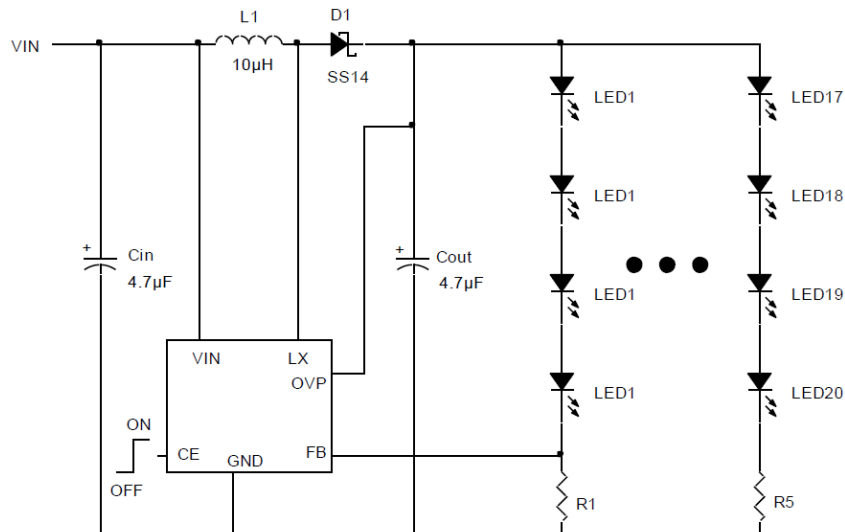



ACE77LE9

High Efficiency Low Noise PFM Step-Up DC/DC Converter

Block Diagram

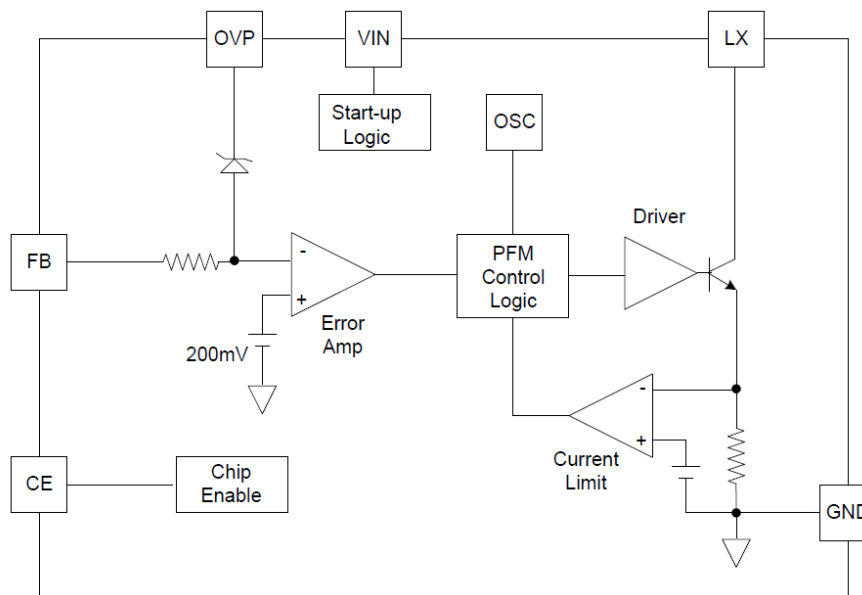

Electrical Characteristics

($V_{IN}=3.0V$, $V_{CE}=3.0V$, $T_A=25^\circ C$, unless otherwise noted)

Symbol	Parameter	Conditions	Min	Typ	Max	Unit
V_{IN}	Input Voltage Range		2.0		6.0	V
V_{FB}	Feedback Voltage		0.190	0.200	0.210	V
I_{FB}	FB Pin Bias Current		10	45	100	nA
I_Q	Quiescent Current	$V_{FB}=0.3V$		93	120	μA
		$V_{CE}=0V$		0.4	1.0	
$F_{OSC-MAX}$	Maximum Switching Frequency	$V_{FB}=0V$		2		MHz
I_{Limit}	Switching Current Limit			1.6		A
V_{CESAT}	Switching VCESAT	$I_{LX}=300mA$		260		mV
I_{LX}	Switching Pin Leak Current	$V_{LX}=5V$		0.11		μA
V_{CEH}	CE Voltage High	CE=0V to 3V	1.5			V
V_{CEL}	CE Voltage Low	CE=3V to 0V			0.4	V
I_{CE}	CE pin Bias Current			18		μA
V_{OVP}	Over Voltage Protection			24		V



ACE77LE9

High Efficiency Low Noise PFM Step-Up DC/DC Converter

Typical Performance Characteristics

($V_{IN}=3.0V$, $V_{CE}=3.0V$, $T_A=25^\circ C$, unless otherwise noted)

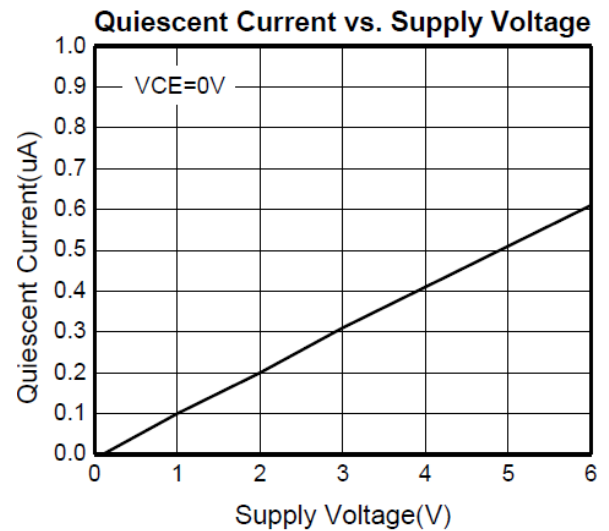
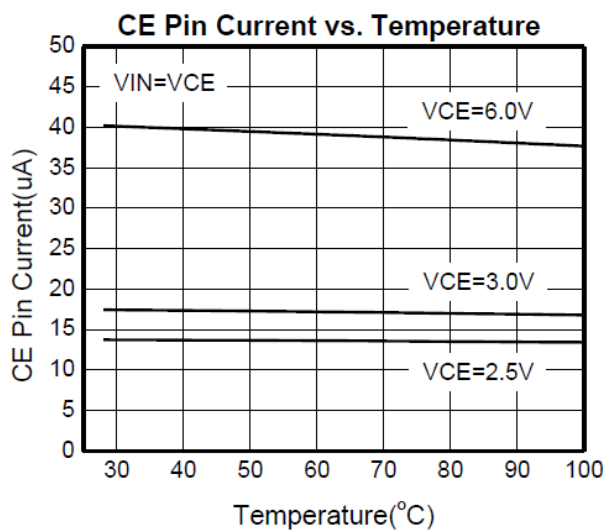
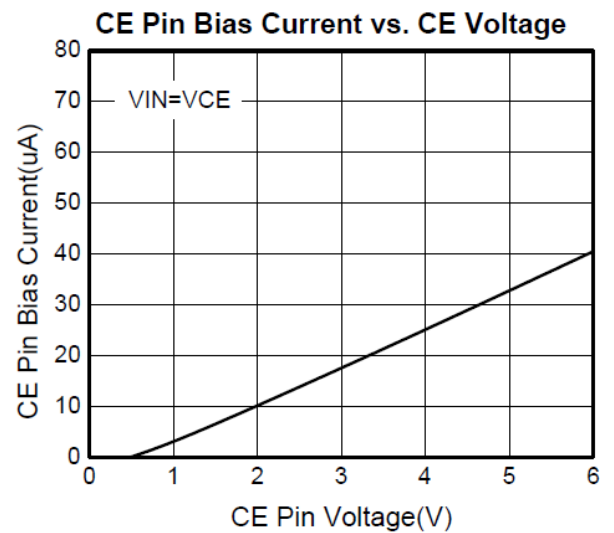
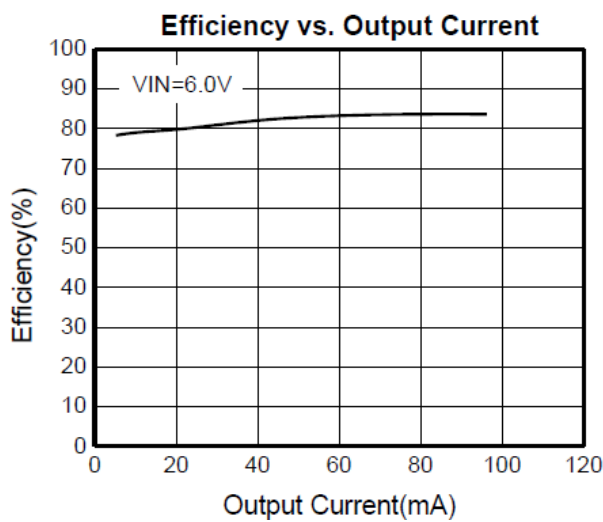
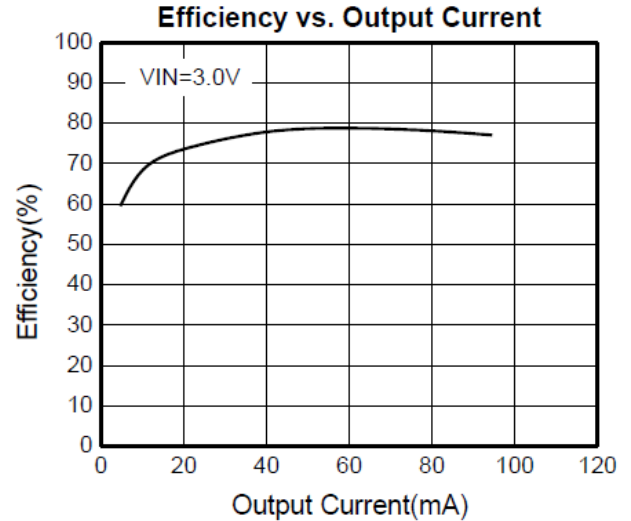
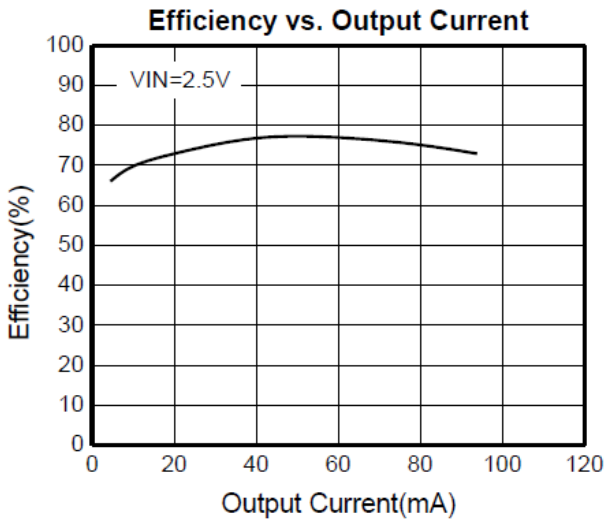



ACE77LE9

High Efficiency Low Noise PFM Step-Up DC/DC Converter

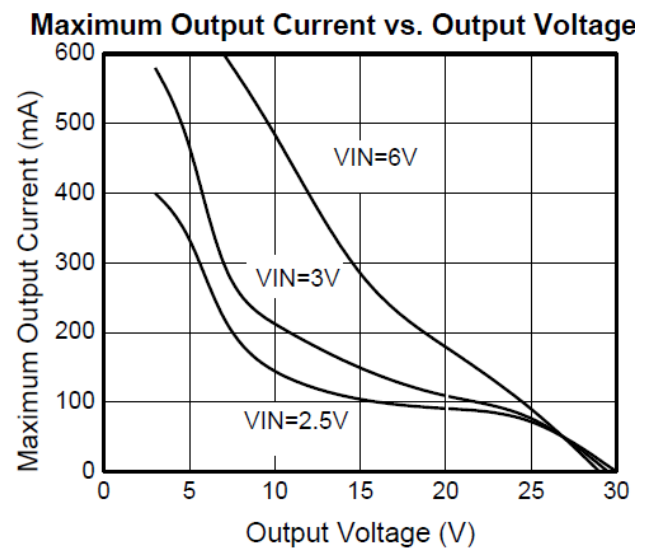
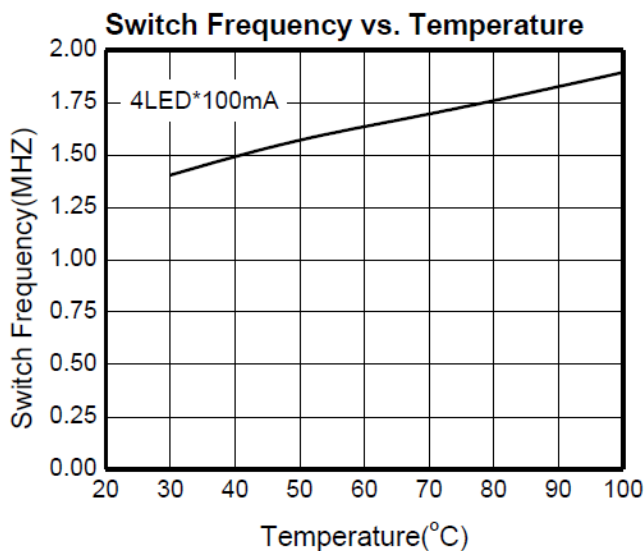
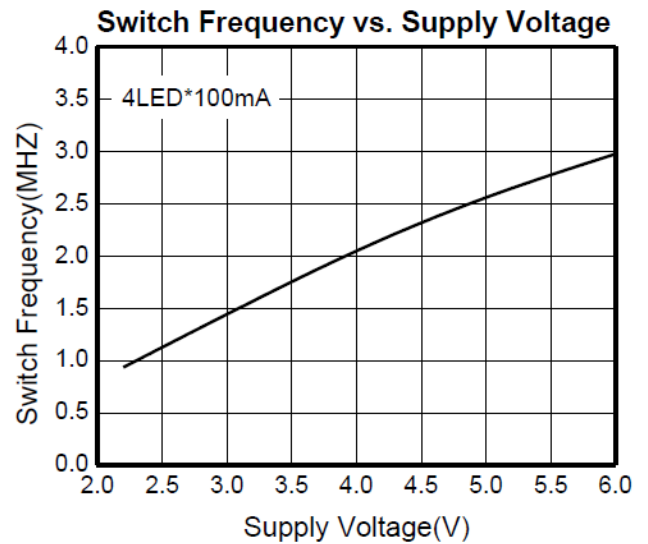
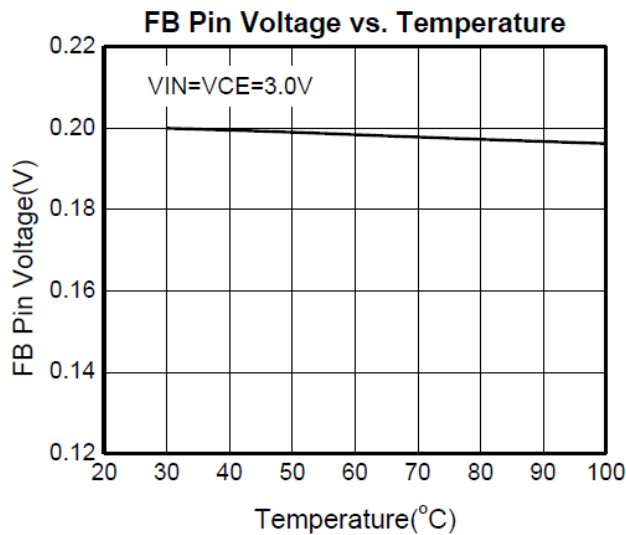
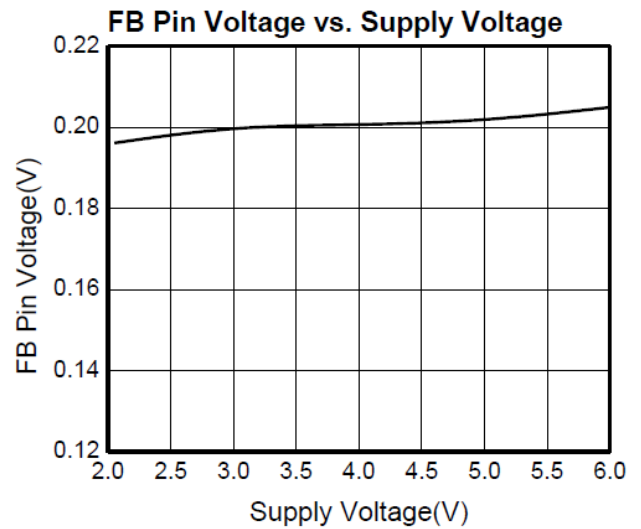
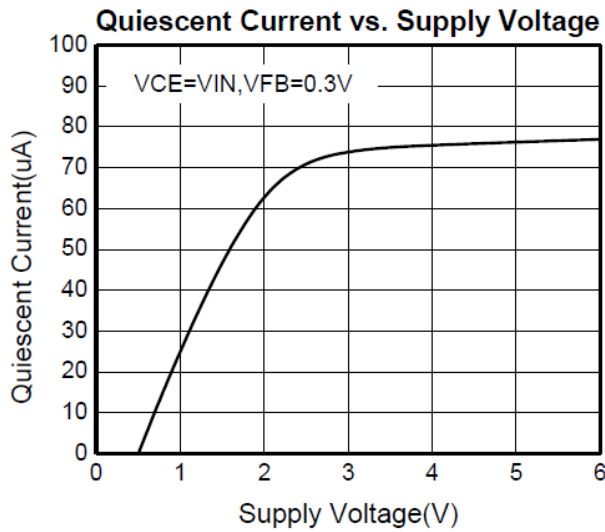



ACE77LE9

High Efficiency Low Noise PFM Step-Up DC/DC Converter

Application Information LED Current Control

The ACE77LE9 regulates the LED current by setting the current sense resistor (R1) connecting to feedback and ground. The ACE77LE9 feedback voltage (VFB) is 0.20V. The LED current (ILED) can be set by a resistor R1. $I_{LED} = 0.20/R1$. In order to have an accurate LED current, a precision resistor is preferred (1% is recommended).

PWM Dimming Control

When adding the PWM signal to CE pin, the ACE77LE9 is turned on or off by the PWM signal, so the LEDs operate at either zero or full current. The average LED current increase proportionally with the duty cycle of the PWM signal. The magnitude of the PWM signal should be higher than the maximum enable voltage of EN pin, in order to let the dimming control perform correctly. The recommended frequency range of the PWM signal is from 100Hz to 100 kHz.

Inductor Selection

The recommended value of inductor is 2.2 μ H to 10 μ H. Small size and better efficiency are the major concerns for portable device, such as ACE77LE9 used for mobile phone. The inductor should have low core loss at 2MHz and low DCR for better efficiency. To avoid inductor saturation current rating should be considered.

Capacitor Selection

Input and output ceramic capacitors of 4.7 μ F are recommended for ACE77LE9 applications. For better voltage filtering, ceramic capacitors with low ESR are recommended. X5R and X7R types are suitable because of their wider voltage and temperature ranges.

Diode Selection

Schottky diode is a good choice for ACE77LE9 because of its low forward voltage drop and fast reverses recovery. Using Schottky diode can get better efficiency. The high speed rectification is also a good characteristic of Schottky diode for high switching frequency. Current rating of the diode must meet the root mean square of the peak current and output average current multiplication as following:

$$I_{D(RMS)} \approx (I_{OUT} \times I_{PEAK})^{1/2}$$

The diode's reverse breakdown voltage should be larger than the output voltage. SS0520 is recommended Schottky diode for rectifier.

Layout Guide

- A full GND plane without gap break.
- Minimized LX node copper area to reduce EMI.
- Minimized FB node copper area and keep far away from noise sources.



ACE77LE9

High Efficiency Low Noise PFM Step-Up DC/DC Converter

Packing Information

SOT-23-6

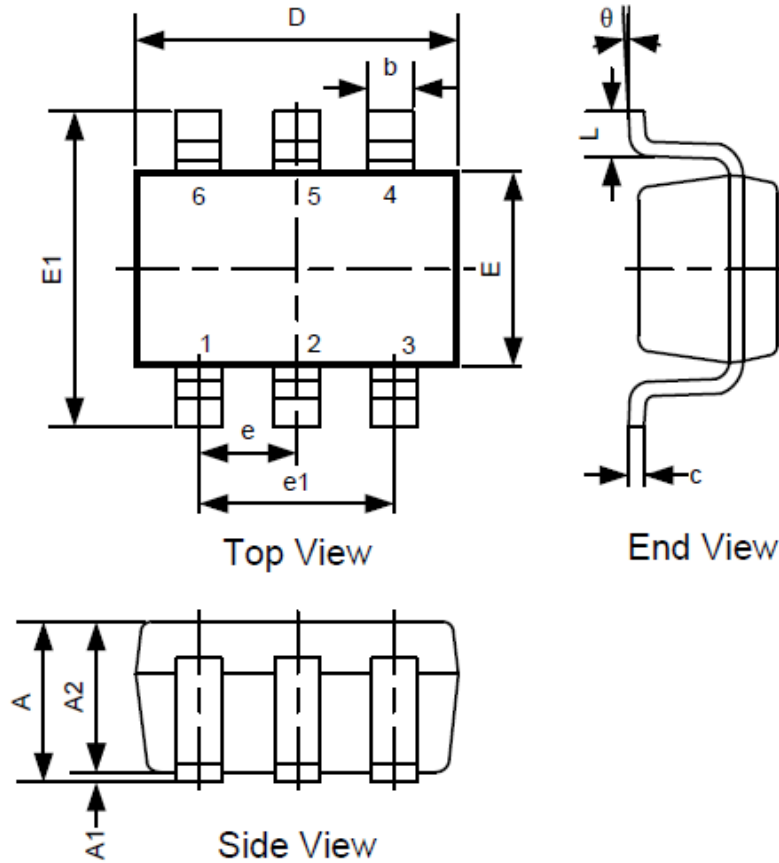

Symbol	Dimensions In Millimeters			Dimensions In Inches		
	Min	Typ	Max	Min	Typ	Max
A	1.013	1.15	1.40	0.040	0.045	0.055
A1	0.00	0.05	0.10	0.000	0.002	0.004
A2	1.00	1.10	1.30	0.039	0.043	0.051
b	0.30		0.50	0.012		0.020
c	0.10	0.15	0.20	0.004	0.006	0.008
D	2.82		3.10	0.111		0.122
E	1.50	1.60	1.70	0.059	0.063	0.067
E1	2.60	2.80	3.00	0.102	0.110	0.118
e	0.95REF			0.037REF		
e1	1.90REF			0.075REF		
L	0.30		0.60	0.012		0.024
θ	0°		8°	0°		8°



ACE77LE9

High Efficiency Low Noise PFM Step-Up DC/DC Converter

Notes

ACE does not assume any responsibility for use as critical components in life support devices or systems without the express written approval of the president and general counsel of ACE Electronics Co., LTD. As used herein:

1. Life support devices or systems are devices or systems which, (a) are intended for surgical implant into the body, or (b) support or sustain life, and whose failure to perform when properly used in accordance with instructions for use provided in the labeling, can be reasonably expected to result in a significant injury to the user.
2. A critical component is any component of a life support device or system whose failure to perform can be reasonably expected to cause the failure of the life support device or system, or to affect its safety or effectiveness.

ACE Technology Co., LTD.
<http://www.ace-ele.com/>