

Super-space-saving Signal Conditioners M3S-UNIT Series

POTENTIOMETER TRANSMITTER

(PC programmable)

Functions & Features

- Provides a DC output proportional to a potentiometer or slidewire position input
- Linearization and burnout protection
- PC programmable
- Universal AC/DC power input
- High-density mounting
- Power and status indicator LED

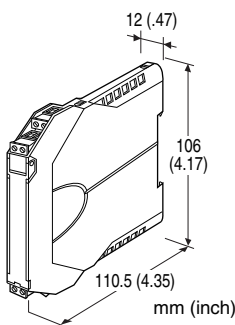

MODEL: M3SXM-1[1]-[2][3]

ORDERING INFORMATION

- Code number: M3SXM-1[1]-[2][3]

Specify a code from below for each [1] through [3].

- (e.g. M3SXM-1Z1-R/Q)
- Output range (e.g. 4 - 20 mA DC)
- Specify the specification for option code /Q (e.g. /C01)

INPUT

1: Total resistance 100 - 5000 Ω
(Configurator software is used to change the input range.)

[1] OUTPUT

Current

Z1: Range 0 - 20 mA DC

Voltage

V2: Range -10 - +10 V DC

V3: Range -5 - +5 V DC

(Configurator software is used to change output over the described range of the selected suffix code.

For changing between suffix codes, set the Output Range

Selector on the side of unit before software adjustment.)

[2] POWER INPUT

AC Power

M2: 100 - 240 V AC (Operational voltage range 90 - 264 V, 47 - 66 Hz)

DC Power

R: 24 V DC
(Operational voltage range 24 V ±10 %, ripple 10 %p-p max.)

Universal

AD: 100 - 240 V AC / 24 - 240 V DC (universal)
(Operational voltage range 90 - 264 V AC, 47 - 66 Hz / 21.6 - 264 V DC, ripple 10 %p-p max.)

[3] OPTIONS

blank: none

/Q: With options (specify the specification)

SPECIFICATIONS OF OPTION: Q

COATING (For the detail, refer to M-System's web site.)

/C01: Silicone coating

/C02: Polyurethane coating

/C03: Rubber coating

RELATED PRODUCTS

- PC configurator software (model: M3SCFG)

Downloadable at M-System's web site.

A dedicated cable is required to connect the module to the PC. Please refer to the internet software download site or the users manual for the PC configurator for applicable cable types.

GENERAL SPECIFICATIONS

Construction: Small-sized front terminal structure

Connection: Euro type connector terminal

Applicable wire size: 0.2 to 2.5 mm², stripped length 8 mm

Housing material: Flame-resistant resin (gray)

Isolation: Input to output to power

Overrange output: -2 - +102 %

(Negative current output is not available.)

Zero adjustment: -2 to +2 % (PC programming)

Span adjustment: 98 to 102 % (PC programming)

Burnout: Upscale standard; downscale or no burnout optional by programming

Power LED: Green light turns on when the power is supplied.

Status indicator LED: Orange LED; Blinking patterns indicate different operating status of the transmitter.

Programming: Downloaded from PC; input type and range, output type and range, zero and span, burnout type, user's linearization table (max. 101 points, specified within -2 to

+102 % for both input and output), etc.
 Refer to the instruction manual for details.
Configurator connection: 2.5 dia. miniature jack;
 RS-232-C level

INPUT SPECIFICATIONS

Sensing current: ≤ 0.15 mA
Minimum span of each range
 0 - 100 Ω : 10 Ω
 0 - 300 Ω : 30 Ω
 0 - 600 Ω : 60 Ω
 0 - 1200 Ω : 120 Ω
 0 - 2500 Ω : 250 Ω
 0 - 5000 Ω : 500 Ω
 If not specified, the input range is 0 - 1200 Ω .

OUTPUT SPECIFICATIONS

■ **DC Current**
Output range: 0 - 20 mA DC
Conformance range: 0 - 20.4 mA DC
Minimum span: 1 mA
Offset: Lower range can be any specific value within the output range provided that the minimum span is maintained.
Load resistance: Output drive 11 V max.
 (e.g. 4 - 20 mA: 550 Ω [11 V \div 20 mA])
 If not specified, the output range is 4 - 20 mA DC.

■ **DC Voltage**
Code V2 (wide spans)
Output range: -10 - +10 V DC
Conformance range: -10.4 - +10.4 V DC
Minimum span: 1 V
Code V3 (narrow spans)
Output range: -5 - +5 V DC
Conformance range: -5.2 - +5.2 V DC
Minimum span: 0.5 V

Offset: Lower range can be any specific value within the output range provided that the minimum span is maintained.
Load resistance: Output drive 1 mA max.
 (e.g. 1 - 5 V: 5000 Ω [5 V \div 1 mA])
 If not specified, the output range is shown below.
 V2: 0 - 10 V DC
 V3: 1 - 5 V DC

INSTALLATION

Power consumption
 •AC:
 Approx. 2 VA at 100 V
 Approx. 3 VA at 200 V
 Approx. 4 VA at 264 V

•DC:
 R: Approx. 0.5 W
 AD: Approx. 1 W
Operating temperature: -10 to +55°C (14 to 131°F)
Operating humidity: 30 to 90 %RH (non-condensing)
Mounting: DIN rail
Weight: 85 g (3.0 oz)

PERFORMANCE in percentage of span

Accuracy: Input accuracy + output accuracy
 (Inversely proportional to the span.)
Input accuracy: (% of range)
 0 - 100 Ω : ± 0.05 (%)
 0 - 300 Ω : ± 0.05
 0 - 600 Ω : ± 0.03
 0 - 1200 Ω : ± 0.03
 0 - 2500 Ω : ± 0.01
 0 - 5000 Ω : ± 0.01
Output accuracy: ± 0.04 % of max. output range
Temp. coefficient: ± 0.015 %/°C (± 0.008 %/°F) of max. span
Response time: ≤ 1 sec. (0 - 90 %)
Burnout response: ≤ 10 sec.
Line voltage effect: ± 0.1 % over voltage range
Insulation resistance: ≥ 100 M Ω with 500 V DC
Dielectric strength: 2000 V AC @1 minute (input to output to power to ground)

CALCULATION EXAMPLES OF OVERALL ACCURACY

[Example] Total Resistance 0 - 1200 Ω , Input Range 250 - 750 Ω , Output Type -5 - +5 V, Output Range 1 - 5 V
 Max. Input Range (1200 Ω) \div Span (500 Ω) \times 0.03 % +
 Max. Output Range (10 V) \div Span (4V) \times 0.04 % = 0.17 %

STANDARDS & APPROVALS

EU conformity:
 EMC Directive
 EMI EN 61000-6-4
 EMS EN 61000-6-2
 Low Voltage Directive
 EN 61010-1
 Installation Category II
 Pollution Degree 2
 Input or output to power: Reinforced insulation (300 V)
 Input to output: Basic insulation (300 V)
 RoHS Directive
 EN 50581

EXTERNAL VIEW

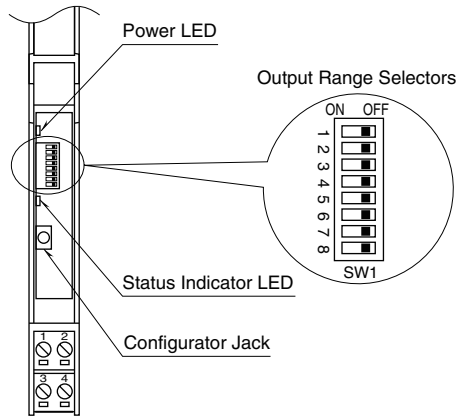

EXTERNAL DIMENSIONS & TERMINAL ASSIGNMENTS unit: mm (inch)

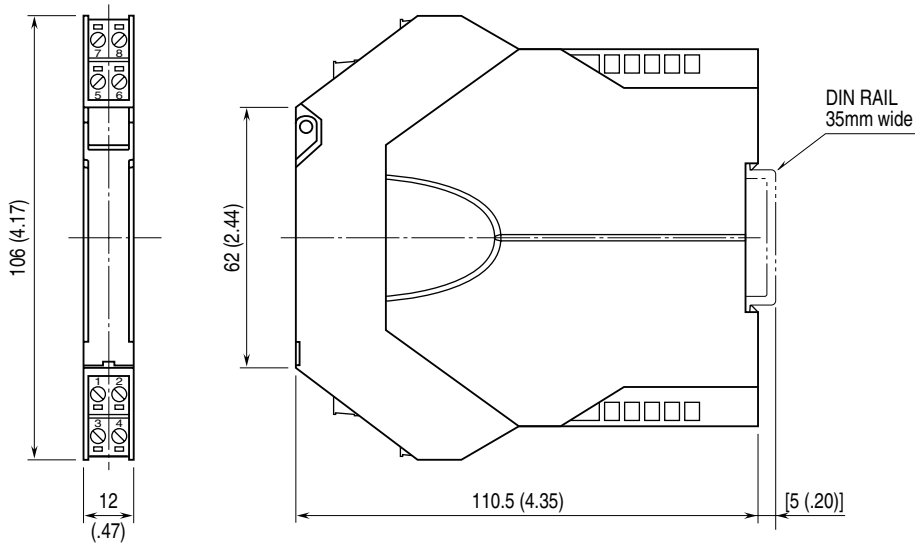

• When mounting, no extra space is needed between units.

SCHEMATIC CIRCUITRY & CONNECTION DIAGRAM

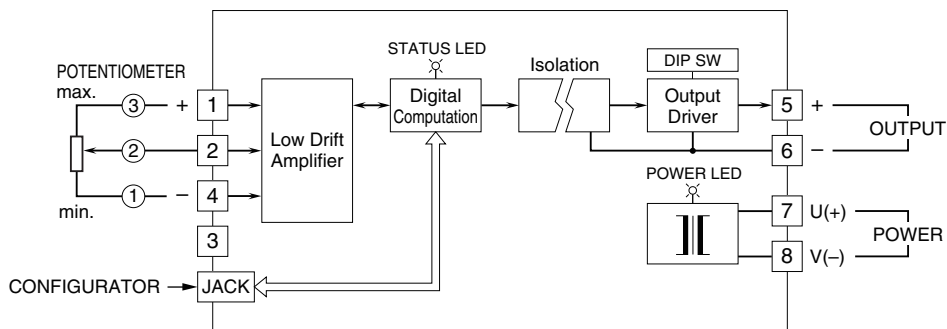

Specifications are subject to change without notice.