

SCHOTTKY BARRIER RECTIFIER

VOLTAGE RANGE: 20 --- 200 V
CURRENT:16.0A

FEATURES

- ◇ Metal-semiconductor junction with guard ring
- ◇ Epitaxial construction
- ◇ Low forward voltage drop, low switching losses
- ◇ High surge capability
- ◇ For use in low voltage, high frequency inverters free wheeling, and polarity protection applications
- ◇ The plastic material carries U/L recognition 94V-0

MECHANICAL DATA

- ◇ Case: JEDEC ITO-220AB, molded plastic
- ◇ Terminals: Axial lead, solderable per MIL-STD-750, Method 2026
- ◇ Polarity: As marked
- ◇ Weight: 0.08 ounces, 2.24 grams
- ◇ Mounting position: Any

ITO - 220AB

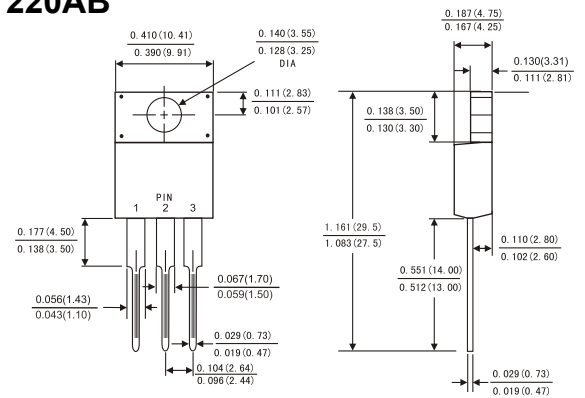

MAXIMUM RATINGS AND ELECTRICAL CHARACTERISTICS

Ratings at 25°C ambient temperature unless otherwise specified.

Single phase, half wave, 60 Hz, resistive or inductive load. For capacitive load, derate by 20%.

| | Symbols | MBRF 1620CT | MBRF 1630CT | MBRF 1640CT | MBRF 1650CT | MBRF 1660CT | MBRF 1680CT | MBRF 16A0CT | MBRF 16150CT | MBRF 16200CT | Units |
|--------------------------------------------------------------------------------------------------|------------------------|-------------|-------------|-------------|-------------|-------------|-------------|-------------|--------------|--------------|-------|
| Maximum repetitive peak reverse voltage | V _{RRM} | 20 | 30 | 40 | 50 | 60 | 80 | 100 | 150 | 200 | Volts |
| Maximum RMS voltage | V _{RMS} | 14 | 21 | 28 | 35 | 42 | 56 | 70 | 105 | 140 | Volts |
| Maximum DC blocking voltage | V _{DC} | 20 | 30 | 40 | 50 | 60 | 80 | 100 | 150 | 200 | Volts |
| Maximum average forward rectified current (see Fig. 1) | Per leg | 8.0 | | | | | | | | | Amps |
| | Total device | 16.0 | | | | | | | | | |
| Peak forward surge current 8.3ms single half sine-wave superimposed on rated load (JEDEC method) | I _{FSM} | 200.0 | | | | | | | | | Amps |
| Maximum instantaneous forward voltage at 16.0 A | V _F | 0.60 | | 0.75 | | 0.85 | | 0.90 | | 0.95 | Volts |
| Maximum instantaneous reverse current at rated DC blocking voltage (Note 1) | T _c = 25°C | 0.2 | | | | | | | | | mA |
| | T _c = 125°C | 30 | | | 50 | | | | | | |
| Typical thermal resistance (Note 2) | R _{θJC} | 3.0 | | | | | | | | | °C/W |
| Operating junction temperature range | T _J | -65 to +150 | | | | | | | | | °C |
| Storage temperature range | T _{STG} | -65 to +150 | | | | | | | | | °C |

- NOTE: 1. Pulse test: 300us pulse width, 1% duty cycle.
2. Measured at 1.0MHz and applied reverse voltage of 4.0V DC.
3. Thermal resistance junction to ambient

FIG.1-FORWARD CURRENT DERATING CURVE

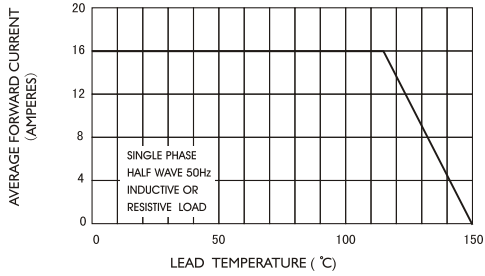

FIG.2-TYPICAL INSTANTANEOUS FORWARD CHARACTERISTICS

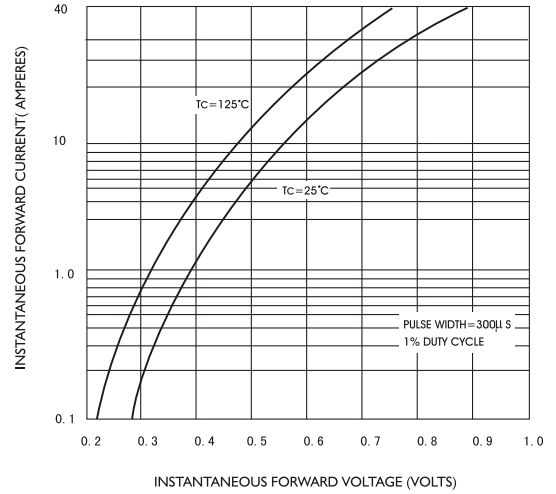

FIG.4-TYPICAL JUNCTION CAPACITANCE

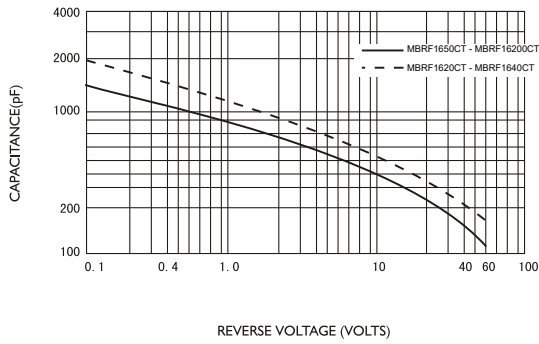

FIG.3-TYPICAL REVERSE CHARACTERISTICS

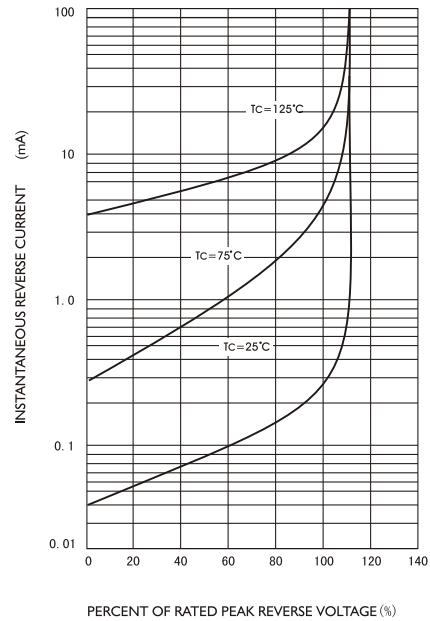

FIG.5-MAXIMUM NON-REPETITIVE PEAK FORWARD SURGE CURRENT

