

Remote I/O R6 Series

THERMOCOUPLE INPUT MODULE

(high-accuracy, 2 points, Euro terminal)

Functions & Features

- Accepts direct input from an thermocouple and provides an isolated, linearized DC signal compact size remote I/O module

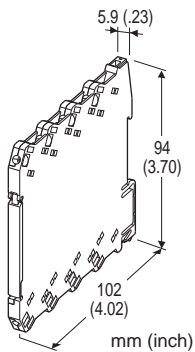

MODEL: R6D-TS2A[1]

ORDERING INFORMATION

- Code number: R6D-TS2A[1]
- Specify a code from below for [1].
(e.g. R6D-TS2A/Q)
- Specify the specification for option code /Q
(e.g. /C01)

[1] OPTIONS

blank: none

/Q: With options (specify the specification)

SPECIFICATIONS OF OPTION: Q

COATING (For the detail, refer to M-System's web site.)

/C01: Silicone coating

/C02: Polyurethane coating

RELATED PRODUCTS

- PC configurator software (model: R6CON)
Downloadable at M-System's web site.
- A dedicated cable is required to connect the module to the PC. Please refer to the internet software download site or the users manual for the PC configurator for applicable cable types.

GENERAL SPECIFICATIONS

Connection

Internal bus: Via the Installation Base (model: R6D-BS)

Input: Euro terminal block (torque 0.3 N·m)

(Applicable wire size: 0.2 to 2.5 mm², stripped length 8 mm)

Internal power: Via the Installation Base (model: R6D-BS)

Housing material: Flame-resistant resin (black)

Isolation: Input 1 to input 2 to internal bus or internal power

Zero adjustments: PC programming

Span adjustments: PC programming

Input type: Selectable with the side DIP SW or PC programming

Burnout detection: Upscale or downscale selectable with the side DIP SW or PC programming

Linearization: Standard

Cold junction compensation: CJC sensor attached to the input terminals

Module address: Selectable with DIP and rotary switches on the side

Configuration mode: With DIP switches on the side panel

Power indicator: Green LED; Refer to the instruction manual for details.

Status indicator: Bi-color (red/green) LED;

Refer to the instruction manual for details.

INPUT SPECIFICATIONS

Thermocouple: K, E, J, T, B, R, S, C, N, U, L, P, PR

Input resistance: 30 kΩ min.

Burnout sensing: ≤ 0.1 μA

| T/C | USABLE RANGE (°C) | CONFORMANCE RANGE (°C) |
|-----------------|-------------------|------------------------|
| K (CA) | -272 to +1472 | -150 to +1370 |
| E (CRC) | -272 to +1100 | -170 to +1000 |
| J (IC) | -260 to +1300 | -180 to +1200 |
| T (CC) | -272 to +500 | -170 to +400 |
| B (RH) | 24 to 1920 | 1000 to 1760 |
| R | -100 to +1860 | 380 to 1760 |
| S | -100 to +1860 | 400 to 1760 |
| C (WRe 5-26) | -52 to +2416 | 100 to 2315 |
| N | -272 to +1400 | -130 to +1300 |
| U | -252 to +700 | -200 to +600 |
| L | -252 to +1000 | -200 to +900 |
| P (Platinel II) | -52 to +1496 | 0 to 1395 |
| (PR) | -52 to +1860 | 300 to 1760 |

INSTALLATION

Current consumption: 20 mA

Operating temperature: -10 to +55°C (14 to 131°F)

Operating humidity: 30 to 90 %RH (non-condensing)

Atmosphere: No corrosive gas or heavy dust

Mounting: Installation Base (model: R6D-BS)

Weight: 70 g (2.5 oz)

PERFORMANCE

Conversion accuracy: $\pm 0.5^{\circ}\text{C}$ ($\pm 0.9^{\circ}\text{F}$) except $\pm 1^{\circ}\text{C}$ ($\pm 1.8^{\circ}\text{F}$) for B, R, S, C, PR

Conversion rate: 250 msec. / 500 msec. (PC programmable.
Factory set to 500 msec.)

Converted data range:

- Engineering unit value ($^{\circ}\text{C}$, K) $\times 10$ (integer)
- Engineering unit value ($^{\circ}\text{F}$)

Data allocation: 2

Cold junction compensation error:

- $\pm 1^{\circ}\text{C}$ max. at $25 \pm 10^{\circ}\text{C}$
- $\pm 1.8^{\circ}\text{F}$ max. at $77 \pm 18^{\circ}\text{F}$

Temp. coefficient: $\pm 0.01\%$ / $^{\circ}\text{C}$ ($\pm 0.006\%$ / $^{\circ}\text{F}$) of max. span

Response time: Conversion rate $\times 2 + 50$ msec. or less

Line voltage effect: $\pm 0.1\%$ over voltage range

Insulation resistance: $\geq 100\text{ M}\Omega$ with 500 V DC

Dielectric strength: 1500 V AC @ 1 minute (input 1 to input 2 to internal bus or internal power to ground)

EXTERNAL VIEW

• Front View (cover opened)

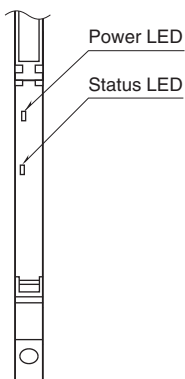

• Side View

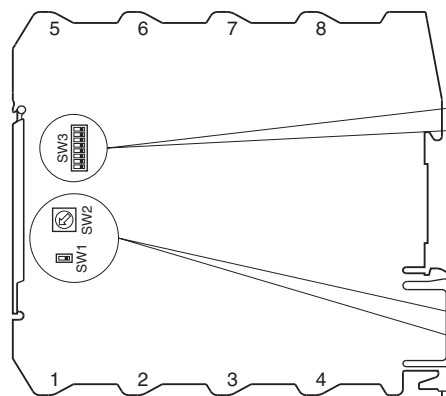

Operating Mode Setting



Module Address Setting

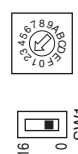

Refer to the instruction manual for setting procedures.

EXTERNAL DIMENSIONS & TERMINAL ASSIGNMENTS unit: mm (inch)

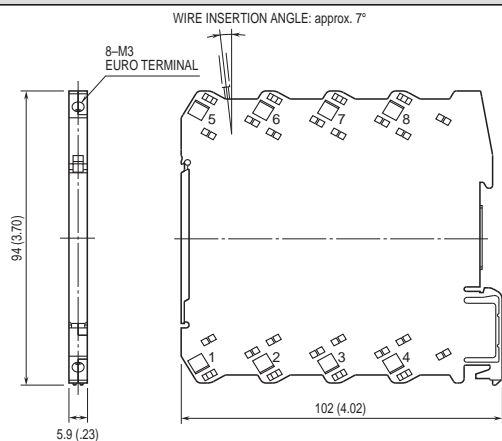

SCHEMATIC CIRCUITRY & CONNECTION DIAGRAM

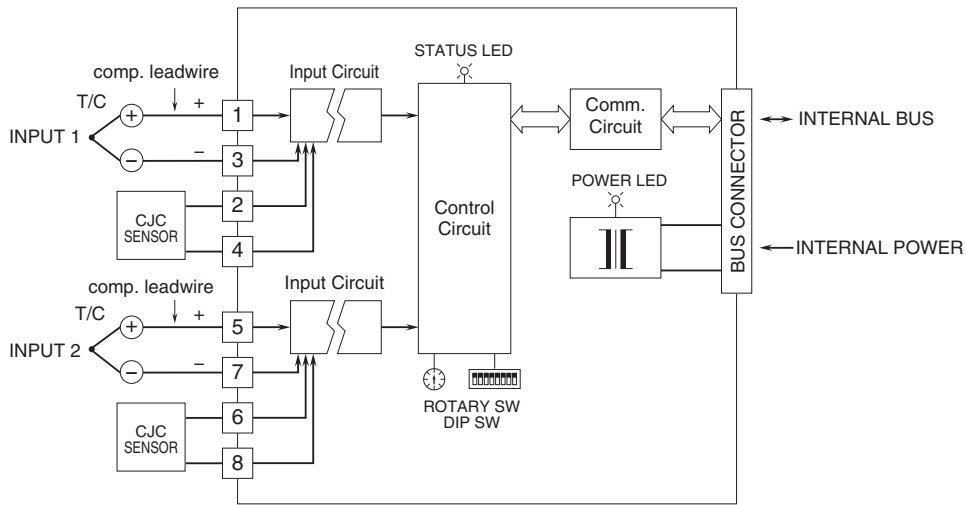

Specifications are subject to change without notice.