



### FEATURES

- RoHS compliant
- 48 V<sub>IN</sub>, Isolated, 5:1 fixed conversion ratio
- 385W power at 48V<sub>IN</sub>
- 300W output at 38 V<sub>IN</sub>, 55°C, 200 LFM
- Industry standard ¼ brick footprint
- Remote enable (primary side, positive or negative)
- Over-temperature, over current protections
- Direct parallel operation for higher power

### DESCRIPTION

The QUS40-096 is a RoHS compliant fixed 5:1 ratio bus converter in an industry standard quarter brick footprint to support Intermediate Bus Architecture (IBA) for powering multiple downstream non-isolated point-of-load (POL) converters. The output is unregulated and the 5:1 fixed ratio is maintained between the input and output voltages. It features input voltage range of 38V to 55V, and provides up to 384W @ 48V<sub>IN</sub> of power or 300W at 38V<sub>IN</sub> @ 55°C, typical efficiency of 9.6V module is 96.6%. It can be parallel for more power.

INPUT CHARACTERISTICS						
Parameter	Conditions <sup>1</sup>	Min.	Typ.	Max.	Units	
Input voltage operating range		38	48	55	V <sub>DC</sub>	
Input voltage absolute maximum				60		
Input undervoltage lockout	Turn-on threshold	34	35.5	36		
	Turn-off threshold	32	33.5	34		
	Hysteresis voltage		2			
Input overvoltage lockout	Turn-on threshold	55		58		
	Turn-off threshold	57	58.5	59.5		
	Hysteresis voltage		2			
Maximum input current	Steady-state (40 A <sub>OUT</sub> )		8.4	9		A <sub>DC</sub>
No-load input current	Enabled state, no load (48V <sub>IN</sub> )		100			mA
Disabled input current	Disabled state (48V <sub>IN</sub> )		7		mA	
Input reflected ripple current	Measured into the input pin Input capacitor 47µF type Nichicon UPM1J470MPH or equivalent			300	mA rms	
Enable - negative logic version Internal 27.4KΩ pulled-up to internal 5.0V	On state range	-0.1		0.8	V <sub>DC</sub>	
	Off state range	2.4		15.0	V <sub>DC</sub>	
Resistance from enable pin to -V <sub>IN</sub>	With +V <sub>IN</sub> pin open, or tied to -V <sub>IN</sub>		16.12		KΩ	

OUTPUT CHARACTERISTICS					
Parameter	Conditions <sup>1</sup>	Min.	Typ.	Max.	Units
Output voltage set point	V <sub>IN</sub> = 48V, I <sub>o</sub> = 0A	9.40	9.50	9.60	V <sub>DC</sub>
Output load regulation	I <sub>o</sub> = 0 to 40A		0.35		V
Output voltage total regulation	V <sub>IN</sub> = 38 to 55V, P <sub>o</sub> = 0 to 300W, T <sub>a</sub> = 55°C	7.0		11.0	V <sub>DC</sub>
Output ripple & noise <sup>2</sup>	20MHz bandwidth		80	150	mV p-p
Output current operating range	Corresponding to P <sub>o</sub> = 300W	0		42	A
Efficiency	V <sub>IN</sub> = 48V, P <sub>o</sub> = 300W		96.6		%
Turn-on delay	From enable, <0.8V to V <sub>o</sub> > 10% for V <sub>IN</sub> = 38V - 55V		0.5	10	ms
Output voltage rise time <sup>3</sup>	From 10% to 90%		12	15	ms
Start-up inhibit time	Enabled: V <sub>IN</sub> applied to 90% V <sub>OUT</sub>		140		ms
Transient response <sup>3</sup>	25% step, 1A/µs, C <sub>o</sub> =1200µF		220	350	%V <sub>o</sub>
Current sharing accuracy (up to 3 in parallel)	At P <sub>o</sub> = 300W		5	10	%
Output turn on overshoot			0	350	mV
Output turn off undershoot			0	350	mV
Maximum output capacitance				3750	µF

<sup>1</sup> V<sub>IN</sub> = 48Vdc, T<sub>a</sub> = 25°C, Airflow = 200LFM for all data unless otherwise noted.

<sup>2</sup> Output Ripple Voltage and noise is specified when measured with a 10µF tantalum and a 1µF ceramic capacitor at the output pins.

<sup>3</sup> During output voltage rise time (15ms Max.), output power shall be limited to 50% constant power.  
Transient response is specified with a 960µF capacitor at the output of the converter.



PROTECTION CHARACTERISTICS					
Parameter	Conditions <sup>1</sup>	Min.	Typ.	Max.	Units
Output over-current shutdown <sup>2</sup>	Auto-restart	44	48	50	A
	Restart rate		80		ms
Over temperature shutdown <sup>3</sup>	Auto-restart		135	140	°C
Over temperature restart hysteresis			10		°C

GENERAL CHARACTERISTICS					
Parameter	Conditions	Min.	Typ.	Max.	Units
Isolation voltage	Input to output	2250			V <sub>dc</sub>
Isolation resistance	Input to output	10			MΩ
Storage temperature range	Non-condensing	-40		125	°C
Operating temperature range		-40		85	°C
Operating humidity	Non-condensing	10		90	%
Thermal measurement location temperature <sup>3</sup>	See mechanical drawing for location			130	°C
Material flammability	UL 94V-0				
MTBF	Calculated per Mil Spec 217 E, or Bellcore at Ta=30°C	2	3.3		x10 <sup>6</sup> Hrs
	Demonstrated	1.3			x10 <sup>6</sup> Hrs

STANDARDS COMPLIANCE	
Standards	Conditions <sup>4</sup>
UL/CSA 60950	Basic insulation

MANUFACTURING TESTING	
<input type="checkbox"/>	Burn-in test
<input type="checkbox"/>	Parametric test

**SAFETY CONSIDERATIONS**

The QUS series of converters are certified to the standards and extent listed in the ‘Standards Compliance’ section in the table above. If this product is built into information technology equipment, the installation must comply with the above standard. Even though the product is safety certified to operate without an input fuse, it is recommended that an input fuse of 15A (max.) is used.

The output of the converter (Vo+/Vo-) is considered to remain within SELV limits when the input to the converter meets SELV or TNV-2 requirements. The converters and materials meet UL 94V-0 flammability ratings.

RoHS COMPLIANCE	
	<p>The QUS40-096 converter is in compliance with the European Union Directive 2002/95/EC (RoHS) with respect to the following substances: lead (Pb), cadmium (Cd), mercury (Hg), hexavalent chromium, polybrominated biphenyls (PBB) and polybrominated diphenyl ethers (PBDE).</p> <p>For further information, please visit <a href="http://www.cd4power.com/rohs">www.cd4power.com/rohs</a></p>

1 VIN = 48Vdc, Ta = 25°C, Airflow = 200LFM for all data unless otherwise noted.  
 2 Input transient: if input voltage increases by 5V in 1µs, output over-current shut-down shall not be triggered (tested with Max. load and Max. output capacitance).  
 3 Thermal shutdown is monitored at the Thermal Measurement Location (TML). See ‘Mechanical Information’ on page 3 for TML location.  
 4 See ‘Safety Considerations’ shown above.

Derating curves are conducted in a controlled environment. End application testing is required to ensure the Thermal Measurement Location temperature is below the maximum specified. Recommended airflow direction is from pin 1 to pin 3, or 3 to 1 (transversal to the unit).

**PACKAGE SPECIFICATIONS**

**MECHANICAL DIMENSIONS**

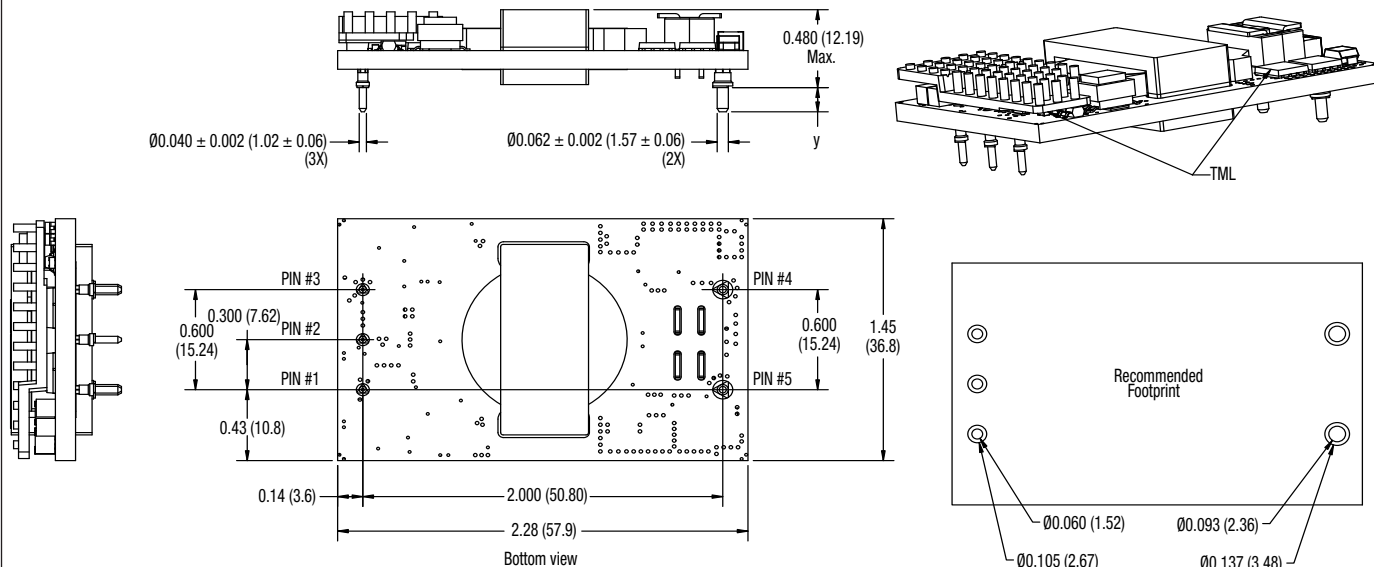

Dimensions: 2.3 (58.4) L x 1.45 (36.83) W x 0.48 (12.19) H Max.  
All dimensions in inches (mm).  
Tolerance: X.X (X.XX) ±0.5 (0.2), X.XX (X.XXX) ±0.25 (0.010).  
Max. 0.480 (12.19) between highest component and mounting plane.

**PIN CONNECTIONS**

Pin	Assignment
1	+VIN
2*	ON/OFF
3	-VIN
4	-VOUT
5	+VOUT

\* Referenced to -VIN

**ORDERING INFORMATION**

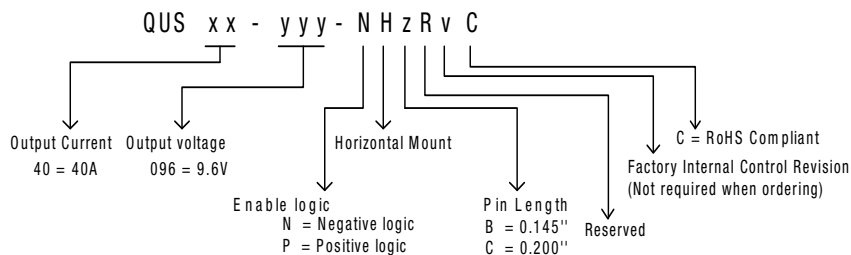

Murata Power Solutions, Inc.  
11 Cabot Boulevard, Mansfield, MA 02048-1151 U.S.A.  
Tel: (508) 339-3000 (800) 233-2765 Fax: (508) 339-6356  
**www.murata-ps.com email: sales@murata-ps.com ISO 9001 REGISTERED**

Murata Power Solutions, Inc. makes no representation that the use of its products in the circuits described herein, or the use of other technical information contained herein, will not infringe upon existing or future patent rights. The descriptions contained herein do not imply the granting of licenses to make, use, or sell equipment constructed in accordance therewith. Specifications are subject to change without notice.  
© 2008 Murata Power Solutions, Inc.

04/22/2008

- USA:** Mansfield (MA), Tel: (508) 339-3000, email: sales@murata-ps.com
- Canada:** Toronto, Tel: (866) 740-1232, email: toronto@murata-ps.com
- UK:** Milton Keynes, Tel: +44 (0)1908 615232, email: mk@murata-ps.com
- France:** Montigny Le Bretonneux, Tel: +33 (0)1 34 60 01 01, email: france@murata-ps.com
- Germany:** München, Tel: +49 (0)89-544334-0, email: munich@murata-ps.com
- Japan:** Tokyo, Tel: 3-3779-1031, email: sales\_tokyo@murata-ps.com  
Osaka, Tel: 6-6354-2025, email: sales\_osaka@murata-ps.com  
**Website: www.murata-ps.jp**
- China:** Shanghai, Tel: +86 215 027 3678, email: shanghai@murata-ps.com  
Guangzhou, Tel: +86 208 221 8066, email: guangzhou@murata-ps.com