

D

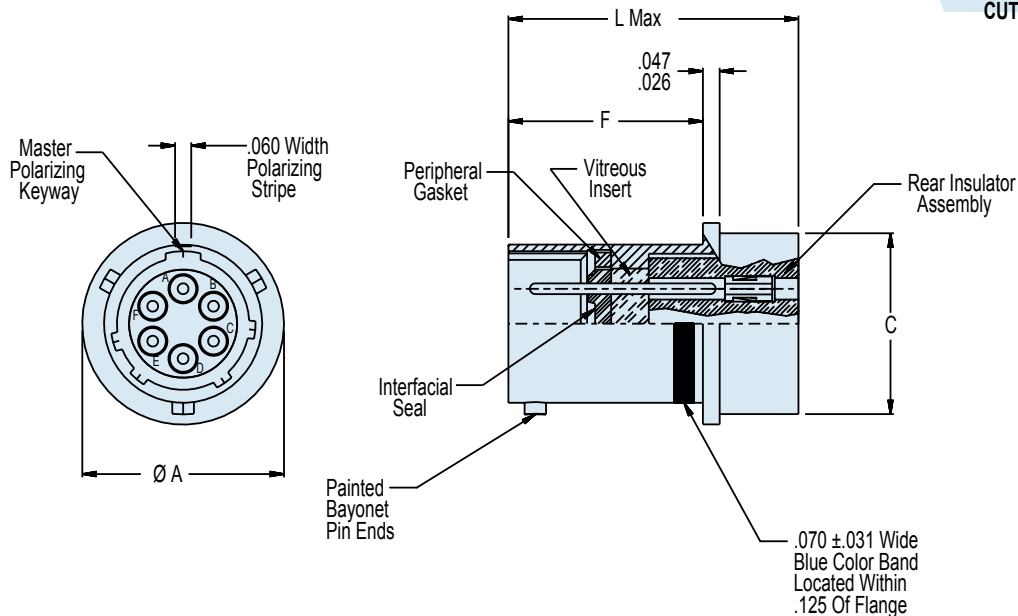

230-020
MIL-DTL-26482 Series II Type Hermetic
Bayonet Coupling Solder Mount Receptacle
with Crimp Removable Contacts • MS3473 Type

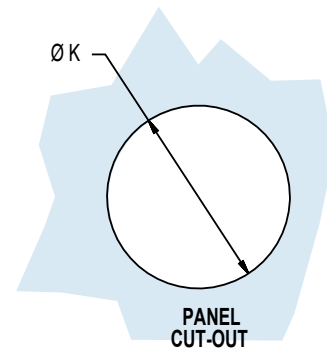

MIL-DTL
26482 Type

HERMETIC LEAK RATE MOD CODES	
Designator	Required Leak Rate
-585A	1 x 10 ⁻¹⁰ cc's Helium per second
-585B	1 x 10 ⁻⁹ cc's Helium per second
-585C	1 x 10 ⁻⁸ cc's Helium per second

TABLE I: CONNECTOR AND CUT-OUT DIMENSIONS					
Shell Size	A Dia Ø.010 (0.3)	C Dia	F	K	L Max
8	.625 (15.9)	.563/.557 (14.3/14.1)	.735/.711 (18.7/18.1)	.570 (14.5)	1.078 (27.4)
10	.750 (19.1)	.673/.667 (17.1/16.9)	.735/.711 (18.7/18.1)	.680 (17.3)	1.078 (27.4)
12	.844 (21.4)	.782/.776 (20.0/19.7)	.735/.711 (18.7/18.1)	.789 (20.0)	1.078 (27.4)
14	.969 (24.6)	.907/.901 (23.0/22.9)	.735/.711 (18.7/18.1)	.914 (23.2)	1.078 (27.4)
16	1.094 (27.8)	1.032/1.026 (26.2/26.1)	.735/.711 (18.7/18.1)	1.039 (26.4)	1.078 (27.4)
18	1.218 (30.9)	1.157/1.151 (29.4/29.2)	.735/.711 (18.7/18.1)	1.164 (29.6)	1.078 (27.4)
20	1.312 (33.3)	1.251/1.245 (31.8/31.6)	.823/.799 (20.9/20.3)	1.258 (32.0)	1.140 (29.0)
22	1.438 (36.5)	1.376/1.371 (35.0/34.8)	.823/.799 (20.9/20.3)	1.383 (35.1)	1.140 (29.0)
24	1.564 (39.7)	1.501/1.495 (38.1/38.0)	.823/.799 (20.9/20.3)	1.508 (38.3)	1.140 (29.0)

D

APPLICATION NOTES

- To be identified with manufacturer's name, part number and date code, space permitting.
- Material/Finish:
 Shell: Z1 - 304L stainless steel/passivate.
 FT - C1215 stainless steel/tin plated.
 Titanium and Inconel® available. Consult factory.
 Contacts - 52 Nickel alloy/gold plate.
 Bayonets - Stainless steel/passivate.
 Seals - Silicone elastomer/N.A.
 Insulation - Glass/N.A.
 Rear insulator - Rigid dielectric/N.A.
- Glenair 230-020 will mate with any QPL MIL-DTL-26482
- Performance:
 Series II bayonet coupling plug of same size and insert polarization.
 Hermeticity - <1 x 10⁻⁷ cc/sec @ 1 atm differential.
 Dielectric withstanding voltage - Consult factory or MIL-STD-1669.
 Insulation resistance - 5000 megohms min @500VDC.
- See Table II for available insert arrangement option.
- Connectors are supplied with applicable crimp socket contacts per MIL-C-39029/22-*** and MS3160-*** insert and removal tool.
- Metric Dimensions (mm) are indicated in parentheses.