

* R5326N (SOT-23-6) and R5326Z (WLCSP-6-P1) are the discontinued product. As of June in 2016.

RICOH

R5326x SERIES

Automatic Mode Shift Dual 150mA LDO

NO.EA-138-140530

OUTLINE

The R5326x Series are CMOS-based voltage regulator ICs with high output voltage accuracy, Typ. 5.5 μ A low supply current, and remarkably improved transient response compared with the conventional low supply current voltage regulators. The supply current of IC itself is automatically shifts between fast mode and low power mode depending on the load current. (The current threshold is fixed internally.) Each of these voltage regulator ICs consists of a voltage reference unit, an error amplifier, resistors for setting the output voltage, a current limit circuit for preventing from the destruction by an over current, and so on.

The chip enable function realizes the standby mode with ultra low supply current.

Since the packages for these ICs are SOT-23-6 and DFN(PLP)1820-6, and chip size package, WLCSP-6-P1, dual LDO regulators are included in each package, high density mounting of the ICs on boards is possible.

FEATURES

- Supply Current (Low Power Mode).....Typ. 5.5 μ A \times 2 (VR1&VR2) (I_{OUT} =0mA)
- Supply Current (Fast Mode).....Typ. 50 μ A \times 2 (VR1&VR2) (I_{OUT} =10mA)
- Standby Current.....Typ. 0.1 μ A (VR1&VR2)
- Dropout VoltageTyp. 0.19V (I_{OUT} =150mA, V_{OUT} =2.8V)
- Ripple Rejection.....Typ. 70dB (f=1kHz)
Typ. 60dB (f=10kHz)
- Input Voltage Range1.4V to 6.0V
- Output Voltage Range.....0.8V to 4.2V (0.1V steps)
(For details, please refer to MARK INFORMATIONS.)
- Output Voltage Accuracy..... \pm 1.0% (V_{OUT} >1.5V)
- Line RegulationTyp. 0.02%/V
- PackagesWLCSP-6-P1, DFN(PLP)1820-6,
SOT-23-6
- Built-in fold-back protection circuit.....Typ. 50mA (Current at short mode)
- Ceramic Capacitor is recommended.1.0 μ F to 3.3 μ F
(Depending on V_{IN} and set V_{OUT} . Refer to the electrical characteristics table.)

APPLICATIONS

- Power source for handheld communication equipment.
- Power source for electrical appliances such as cameras, VCRs and camcorders.
- Power source for battery-powered equipment.

* R5326N (SOT-23-6) and R5326Z (WLCSP-6-P1) are the discontinued product. As of June in 2016.

R5326x

BLOCK DIAGRAMS

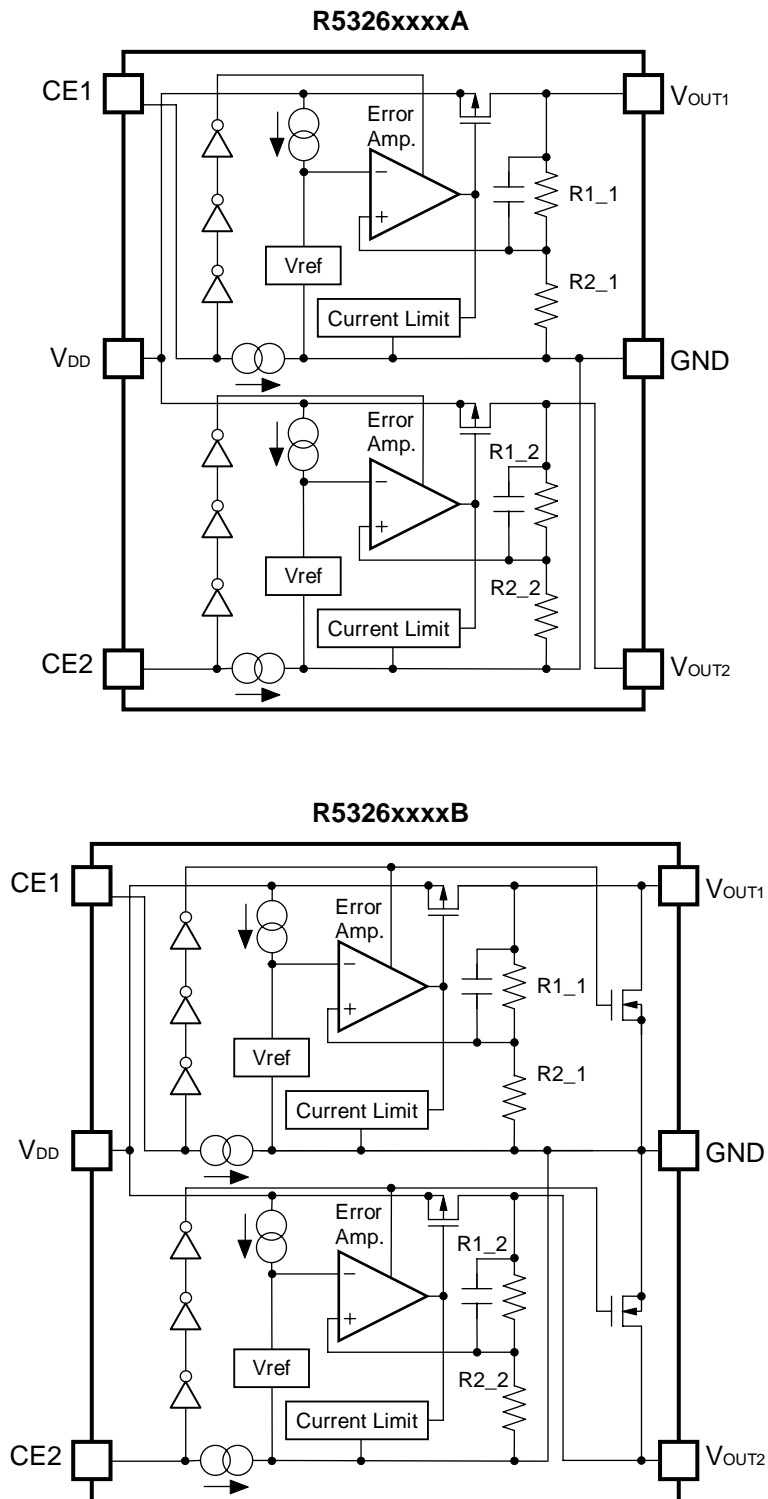

* R5326N (SOT-23-6) and R5326Z (WLCSP-6-P1) are the discontinued product. As of June in 2016.

R5326x

SELECTION GUIDE

The output voltage, auto discharge function, package for the ICs can be selected at the user's request.

Product Name	Package	Quantity per Reel	Pb Free	Halogen Free
R5326Zxxx*-E2-F	WLCSP-6-P1	5,000 pcs	Yes	Yes
R5326Kxxx*-TR	DFN(PLP)1820-6	5,000 pcs	Yes	Yes
R5326Nxxx*-TR-FE	SOT-23-6	3,000 pcs	Yes	Yes

xxx : The combination of output voltage for each channel can be designated by serial numbers. (from 001)
The output voltage for each channel can be set in the range from 0.8V to 4.2V in 0.1V steps.
(For details, please refer to MARK INFORMATION.)

* : The auto discharge function at off state are options as follows.
(A) without auto discharge function at off state
(B) with auto discharge function at off state

* R5326N (SOT-23-6) and R5326Z (WLCSP-6-P1) are the discontinued product. As of June in 2016.

R5326x

PIN CONFIGURATIONS

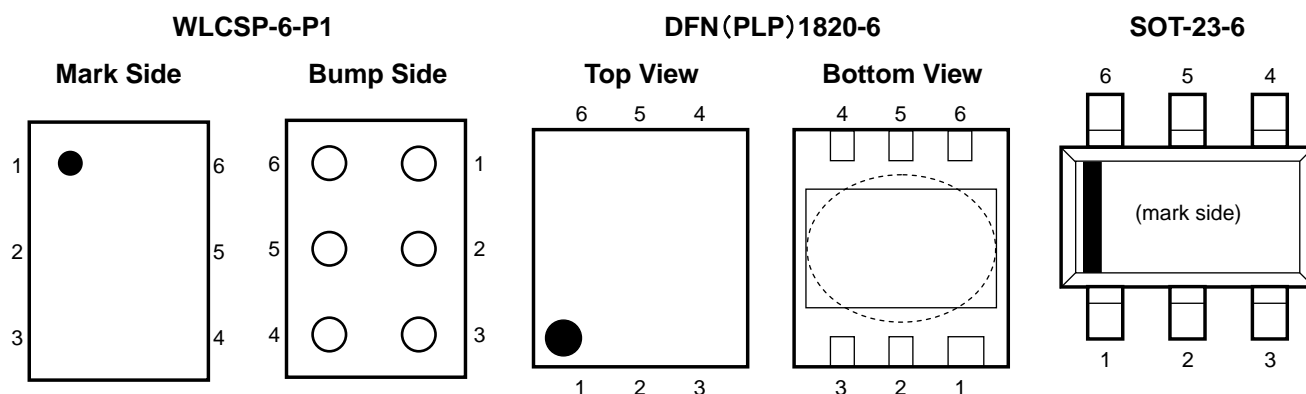

PIN DESCRIPTIONS

- WLCSP-6-P1, SOT-23-6

Pin No	Symbol	Pin Description
1	V_{OUT1}	Output Pin 1
2	V_{DD}	Input Pin
3	V_{OUT2}	Output Pin 2
4	CE2	Chip Enable Pin 2 ("H" Active)
5	GND	Ground Pin
6	CE1	Chip Enable Pin 1 ("H" Active)

- DFN(PLP)1820-6

Pin No	Symbol	Pin Description
1	V_{OUT2}	Output Pin 2
2	V_{DD}	Input Pin
3	V_{OUT1}	Output Pin 1
4	CE1	Chip Enable Pin 1 ("H" Active)
5	GND	Ground Pin
6	CE2	Chip Enable Pin 2 ("H" Active)

*) Tab is GND level. (They are connected to the reverse side of this IC.)

The tab is better to be connected to the GND, but leaving it open is also acceptable.

* R5326N (SOT-23-6) and R5326Z (WLCSP-6-P1) are the discontinued product. As of June in 2016.

R5326x

ABSOLUTE MAXIMUM RATINGS

Symbol	Item	Rating	Unit
V_{IN}	Input Voltage	6.5	V
V_{CE}	Input Voltage (CE Pin)	-0.3 to 6.5	V
V_{OUT}	Output Voltage	-0.3 to $V_{IN}+0.3$	V
I_{OUT1}, I_{OUT2}	Output Current	200	mA
P_D	Power Dissipation (WLCSP-6-P1) *	633	mW
	Power Dissipation (DFN(PLP)1820-6) *	880	
	Power Dissipation (SOT-23-6) *	420	
T_{opt}	Operating Temperature Range	-40 to 85	°C
T_{stg}	Storage Temperature Range	-55 to 125	°C

*) For Power Dissipation, please refer to PACKAGE INFORMATION.

ABSOLUTE MAXIMUM RATINGS

Electronic and mechanical stress momentarily exceeded absolute maximum ratings may cause the permanent damages and may degrade the life time and safety for both device and system using the device in the field. The functional operation at or over these absolute maximum ratings is not assured.

RECOMMENDED OPERATING CONDITIONS (ELECTRICAL CHARACTERISTICS)

All of electronic equipment should be designed that the mounted semiconductor devices operate within the recommended operating conditions. The semiconductor devices cannot operate normally over the recommended operating conditions, even if when they are used over such conditions by momentary electronic noise or surge. And the semiconductor devices may receive serious damage when they continue to operate over the recommended operating conditions.

* R5326N (SOT-23-6) and R5326Z (WLCSP-6-P1) are the discontinued product. As of June in 2016.

R5326x

ELECTRICAL CHARACTERISTICS

• R5326xxxxA/B

VR1/VR2

T_{opt}=25°C

Symbol	Item	Conditions	MIN.	TYP.	MAX.	Unit	
V _{OUT}	Output Voltage	V _{IN} -V _{OUT} =1V I _{OUT} =1mA	V _{OUT} > 1.5V	×0.99		×1.01	V
			V _{OUT} ≤ 1.5V	-15		+15	mV
I _{OUT}	Output Current	V _{IN} -V _{OUT} =1V	150			mA	
ΔV _{OUT} /ΔI _{OUT}	Load Regulation	V _{IN} -V _{OUT} =1V 1mA ≤ I _{OUT} ≤ 150mA			80	mV	
V _{DIF}	Dropout Voltage	I _{OUT} =150mA	0.8V ≤ V _{OUT} <0.9V		0.62	0.87	V
			0.9V ≤ V _{OUT} <1.0V		0.58	0.78	
			1.0V ≤ V _{OUT} <1.2V		0.48	0.69	
			1.2V ≤ V _{OUT} <1.5V		0.40	0.59	
			1.5V ≤ V _{OUT} <2.0V		0.31	0.48	
			2.0V ≤ V _{OUT} <2.8V		0.22	0.37	
			2.8 ≤ V _{OUT}		0.19	0.27	
I _{SS1}	Supply Current (Low Power Mode)	V _{IN} -V _{OUT} =1V, I _{OUT} =0mA		5.5	16	μA	
I _{SS2}	Supply Current (Fast Mode)	V _{IN} -V _{OUT} =1V, I _{OUT} =10mA		50	105	μA	
I _{standby}	Standby Current	V _{IN} =6V, V _{CE1} =V _{CE2} =GND		0.1	1.0	μA	
I _{OUTL}	Low Power Mode Current threshold	V _{IN} -V _{OUT} =1V, I _{OUT} =30mA to 1μA		0.6		mA	
I _{OUTH}	Fast Response Mode Current threshold	V _{IN} -V _{OUT} =1V, I _{OUT} =1μA to 30mA		3		mA	
ΔV _{OUT} /ΔV _{IN}	Line Regulation	V _{OUT} +0.5V ≤ V _{IN} ≤ 6V I _{OUT} =30mA (*V _{IN} ≥ 1.8V)		±0.02	±0.2	%/V	
RR	Ripple Rejection	Ripple 0.2Vp-p, V _{IN} -V _{OUT} =1V, I _{OUT} =30mA (In case that V _{OUT} <1.5V, V _{IN} -V _{OUT} =1.5V)	f=1kHz		70		dB
			f=10kHz		60		
V _{IN}	Input Voltage		1.4		6.0	V	
ΔV _{OUT} /ΔT _{opt}	Output Voltage Temperature Coefficient	I _{OUT} =30mA, -40°C ≤ T _{opt} ≤ 85°C		±100		ppm/°C	
I _{sc}	Short Current Limit	V _{OUT} =0V		50		mA	
I _{PD}	CE Pull-down Current		0.15	0.30	0.45	μA	
V _{CEH}	CE Input Voltage "H"		1.0		6.0	V	
V _{CEL}	CE Input Voltage "L"		0		0.4	V	
en	Output Noise	BW=10Hz to 100kHz		30		μVrms	
R _{LOW}	Low Output Nch Tr. ON Resistance (of B version)			40		Ω	

TYPICAL APPLICATION

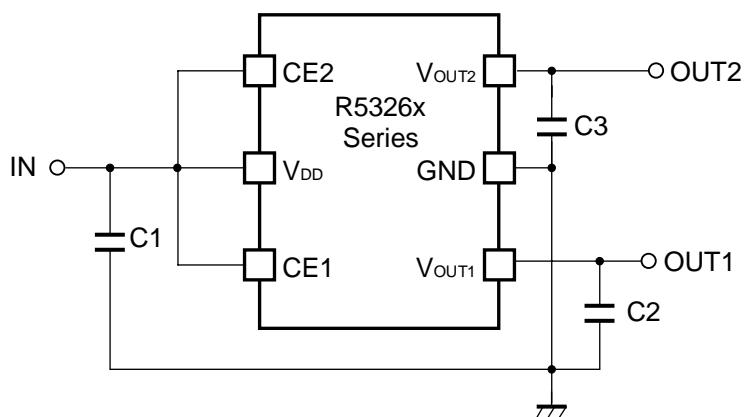

(External Components)

Capacitor; Ceramic Type

C1 : 1.0 μ F Ceramic

C2, C3 : Refer to the following table

Recommended Ceramic capacitor for Output (C2, C3)

Output Voltage Range	Minimum Input Voltage	
	$1.4V \leq V_{IN} < 1.65V$	$1.65V \leq V_{IN}$
$0.8V \leq V_{OUT} < 1.2V$	3.3 μ F or more	2.2 μ F or more
$1.2V \leq V_{OUT} \leq 4.2V$	3.3 μ F or more	1.0 μ F or more

Output Capacitors

3.3 μ F (Murata) GRM219B31A335KE18B

2.2 μ F (Murata) GRM155B30J225M

1.0 μ F (Murata) GRM155B31A105KE15

R5326x

TECHNICAL NOTES

When using these ICs, consider the following points:

Mounting on PCB

Make V_{DD} and GND lines sufficient. If their impedance is high, noise pickup or unstable operation may result. Connect a capacitor with a capacitance value as much as $1.0\mu\text{F}$ or more as C1 between V_{DD} and GND pin, and as close as possible to the pins.

Set external components, especially the output capacitor, as close as possible to the ICs, and make wiring as short as possible.

Phase Compensation

In these ICs, phase compensation is made for securing stable operation even if the load current is varied. For this purpose, use capacitors C2 and C3 which are shown below table "Recommended Ceramic capacitor for output". If you use a tantalum type capacitor and ESR value of the capacitor is large, output might be unstable. Evaluate your circuit with considering frequency characteristics.

TEST CIRCUITS

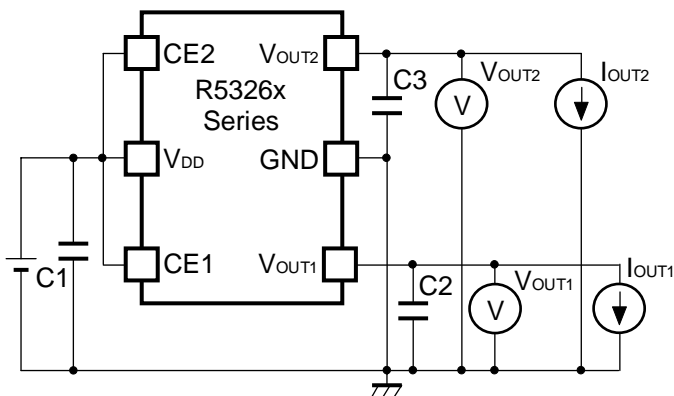

C1=Ceramic $1.0\mu\text{F}$
C2,C3=refer to the term of the external capacitors

Fig.1 Standard test Circuit

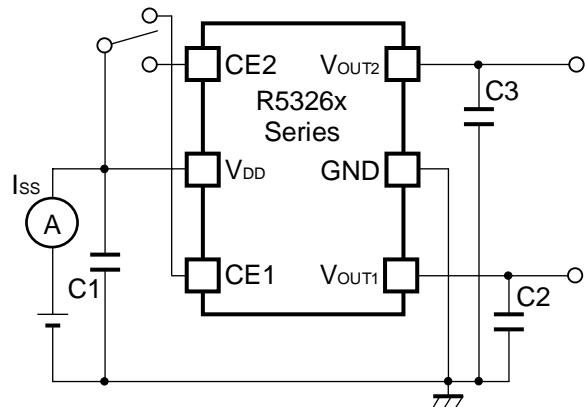

C1=Ceramic $1.0\mu\text{F}$
C2,C3=refer to the term of the external capacitors

Fig.2 Supply Current Test Circuit

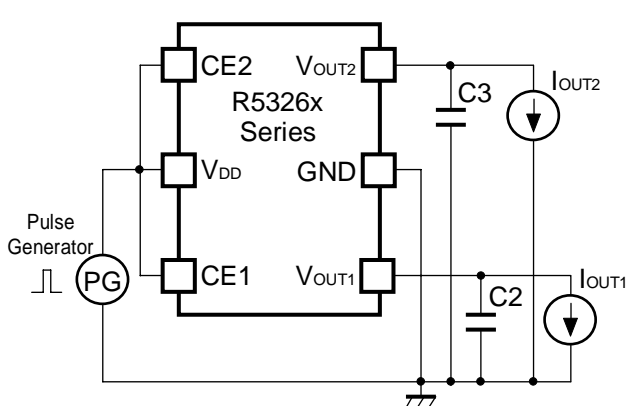

C2,C3= refer to the term of the external capacitors

Fig.3 Ripple Rejection, Line Transient Response Test Circuit

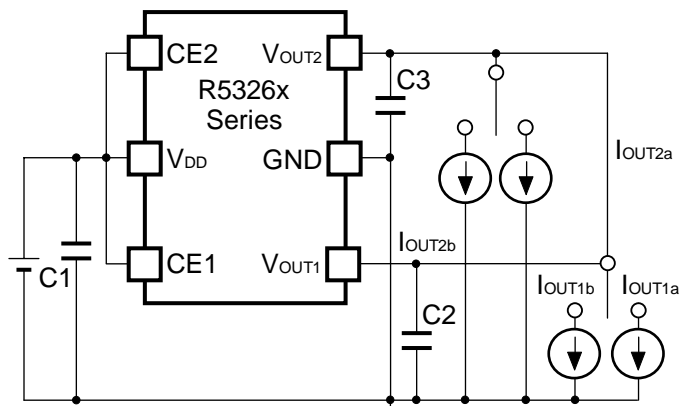

C1=Ceramic $1.0\mu\text{F}$
C2,C3= refer to the term of the external capacitors

Fig.4 Load Transient Response Test Circuit

TYPICAL CHARACTERISTICS

1) Output Voltage vs. Output Current

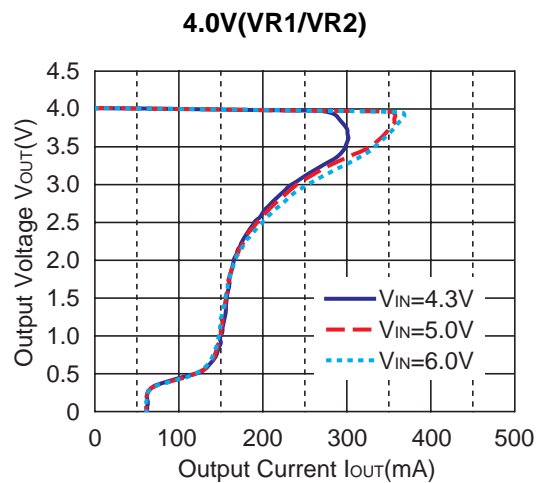
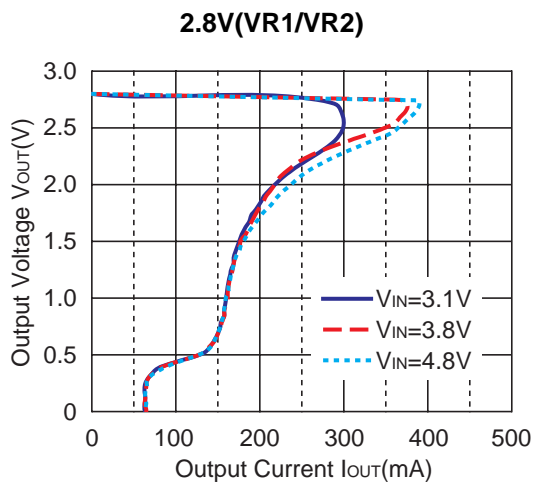
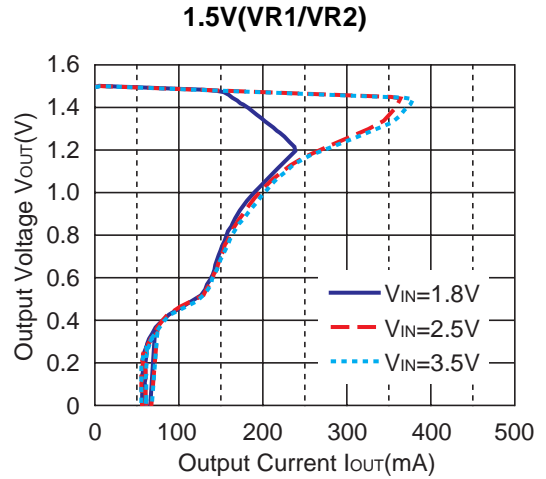
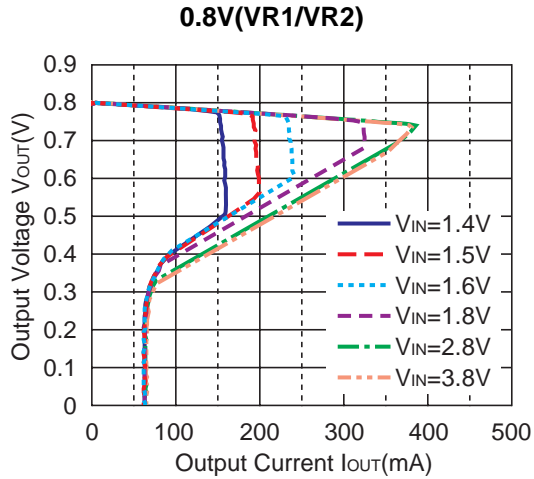

2) Input Voltage vs. Output Voltage

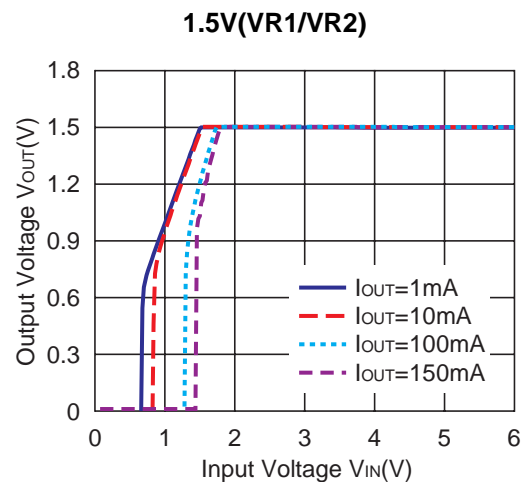
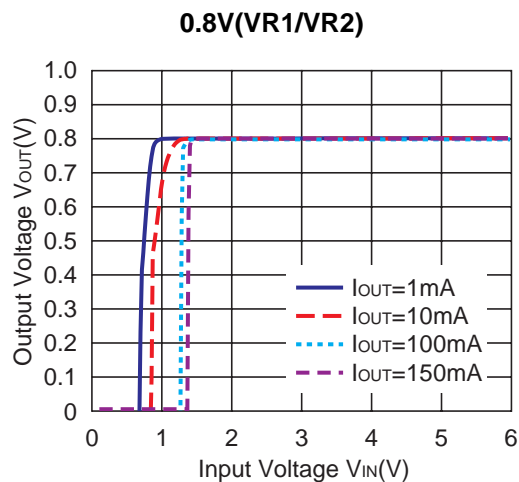

R5326x

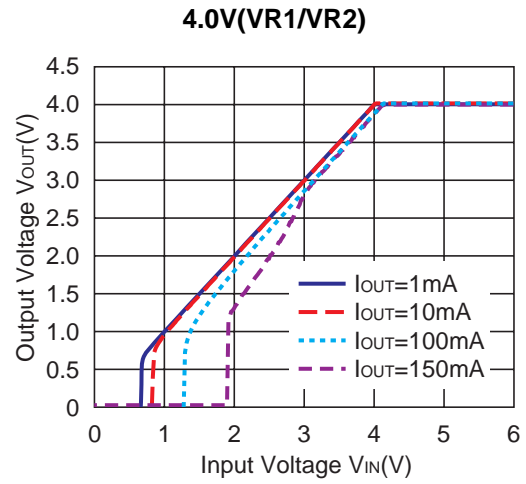
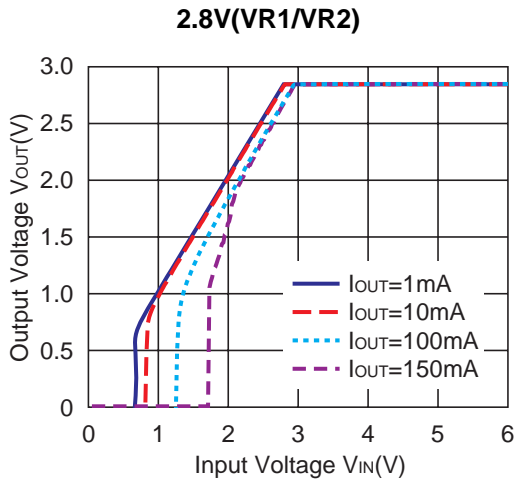

3) Supply Current vs. Input Voltage

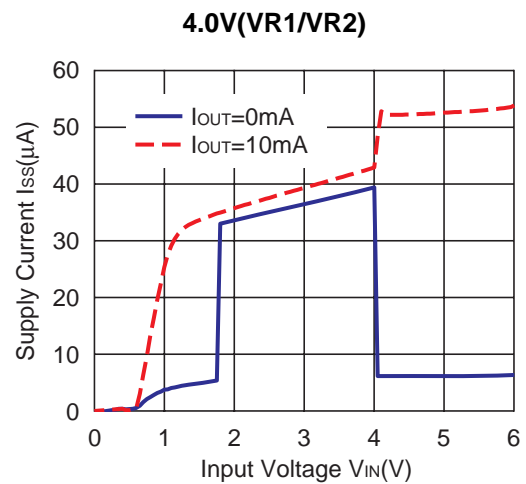
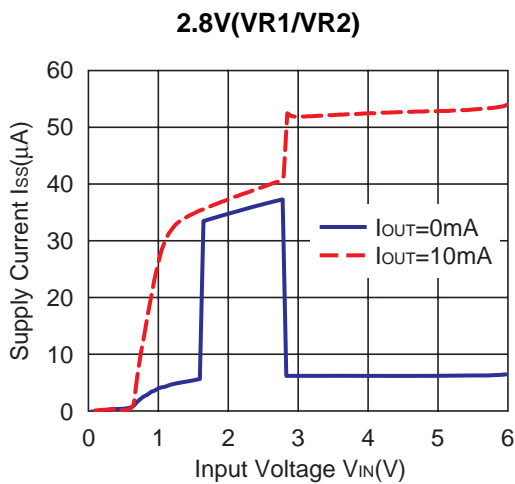
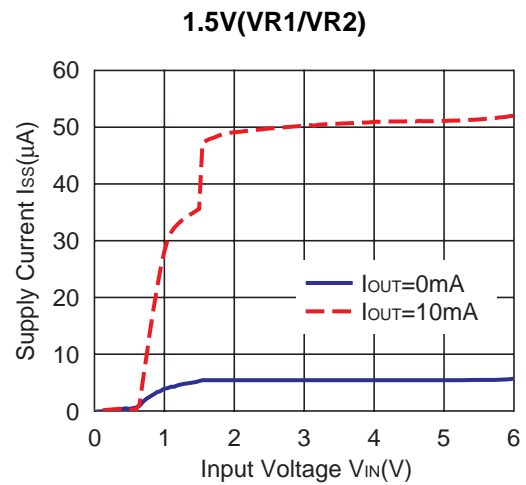
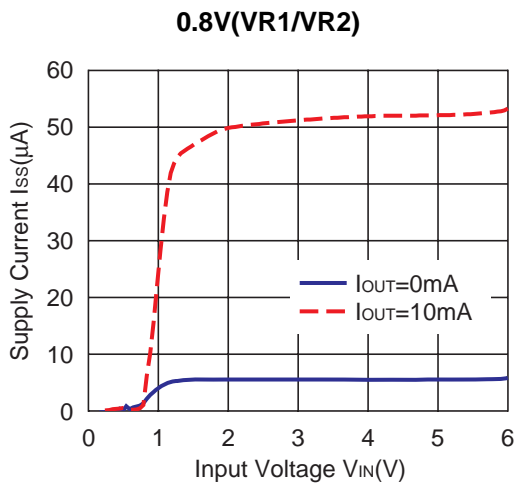

4) Supply current vs. Output current

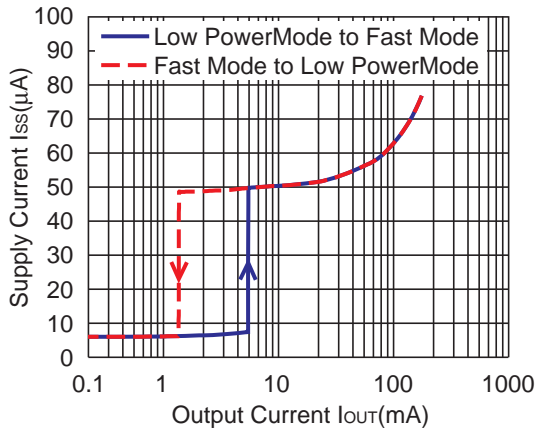

5) Output Voltage vs. Temperature

0.8V(VR1/VR2)

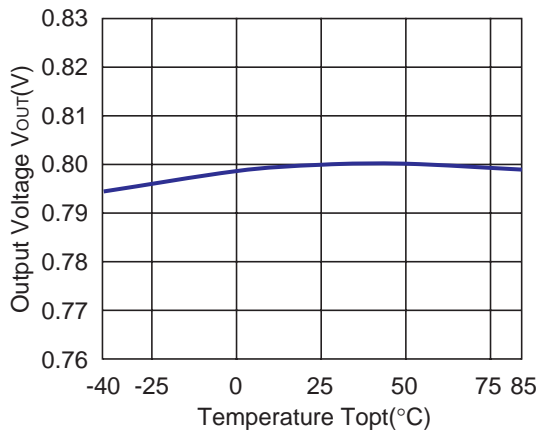

1.5V(VR1/VR2)

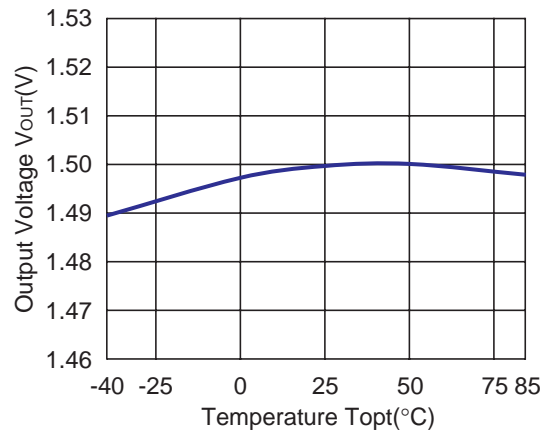

2.8V(VR1/VR2)

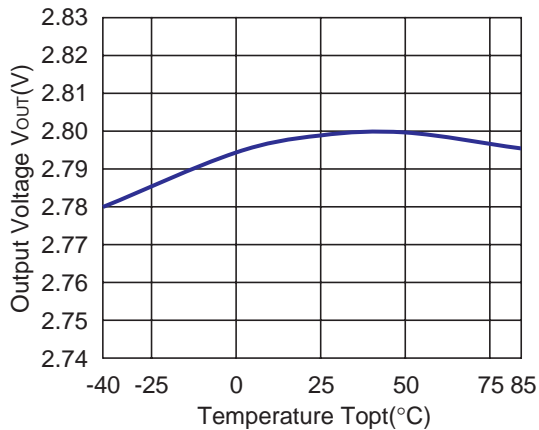

4.0V(VR1/VR2)

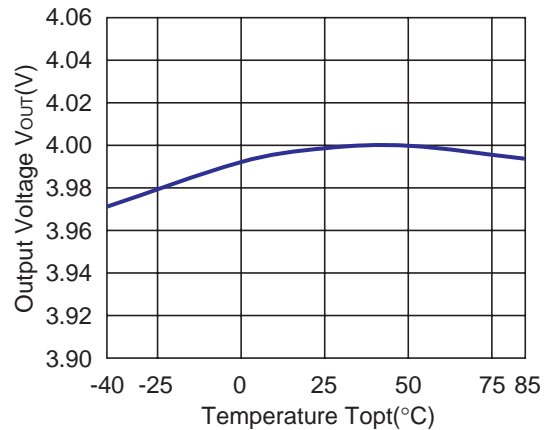

R5326x

6) Supply Current vs. Temperature

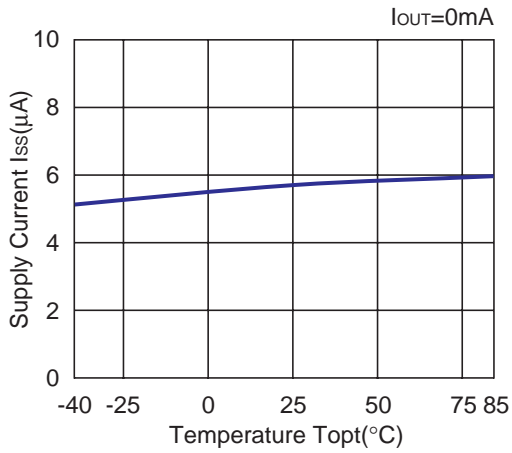

7) Dropout Voltage vs. Output Current

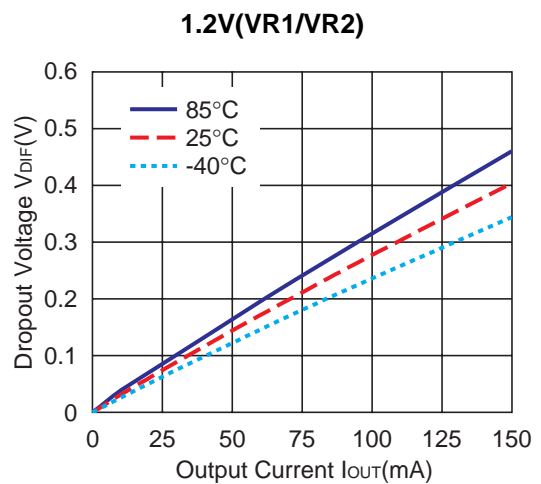
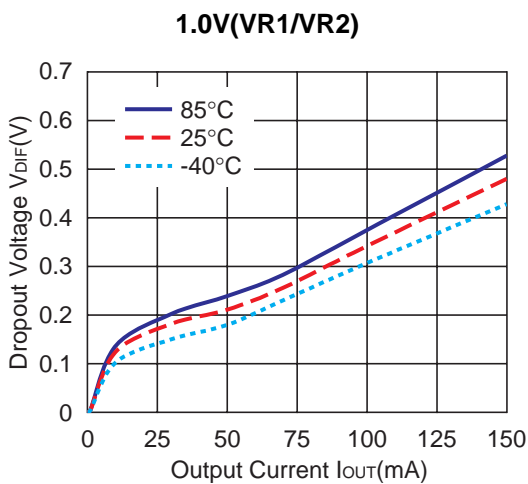
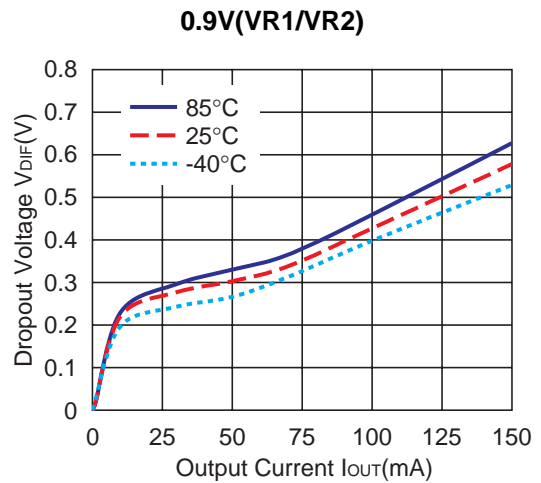
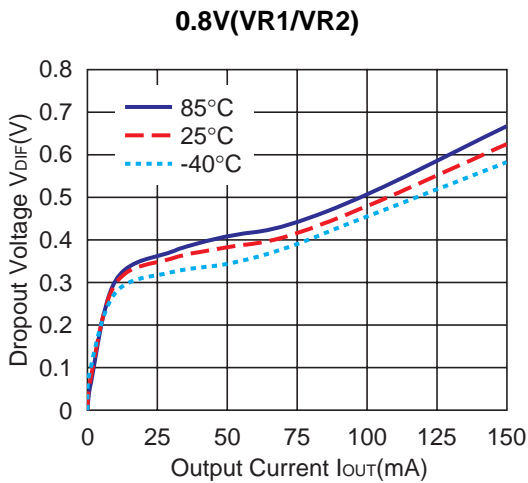

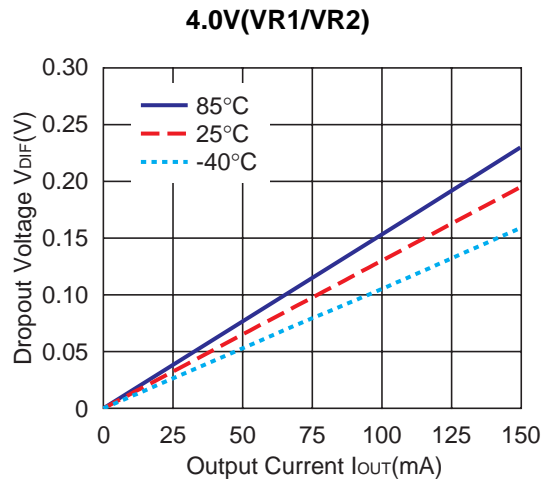
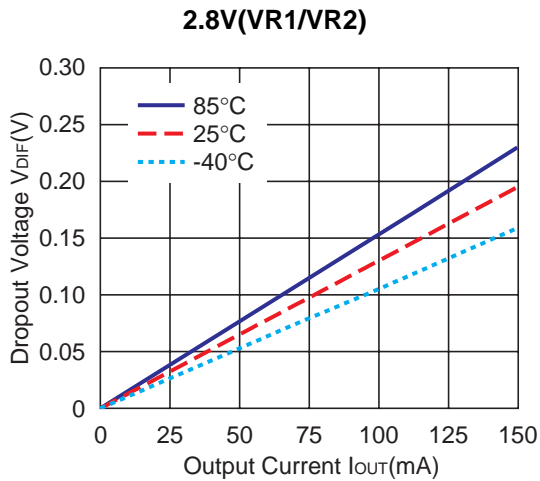
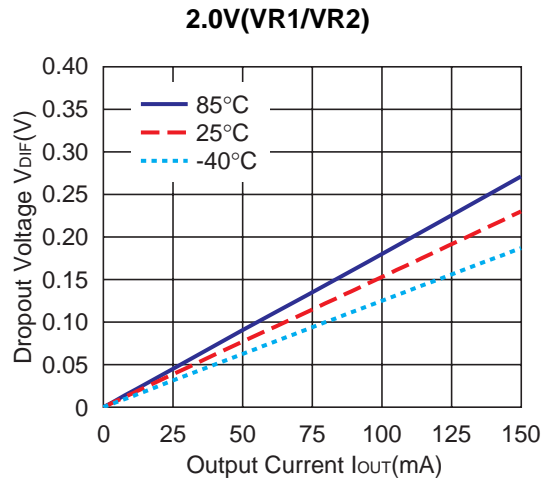
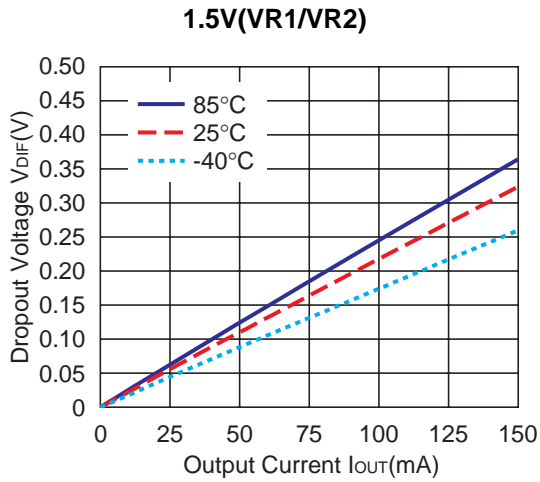

8) Dropout Voltage vs. Set Output Voltage

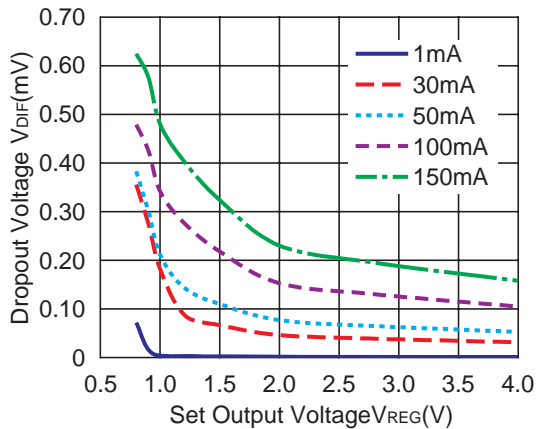

R5326x

9) Ripple Rejection vs. Input Voltage

(Topt=25°C, Ripple 0.5Vp-p, CIN=none, Cout=Ceramic 1.0µF)

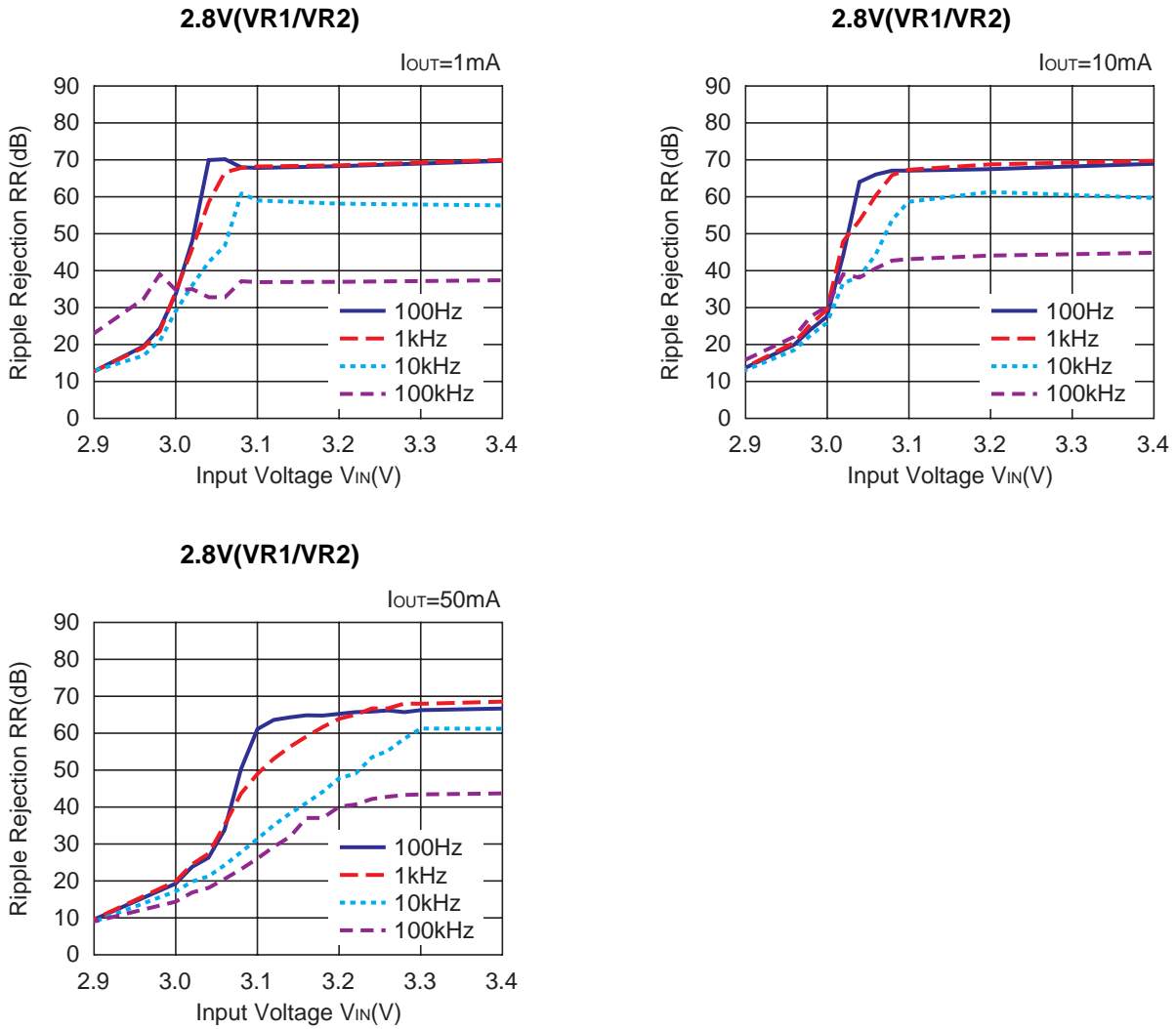

10) Minimum Operating Voltage

0.8V(VR1/VR2)

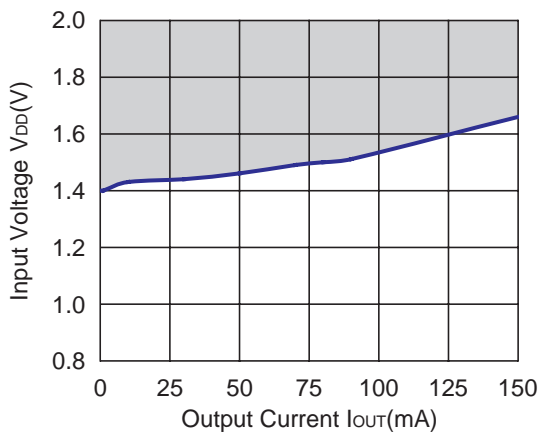

Hatched area is available for 0.8V output

11) Ripple Rejection vs Frequency (C_{IN}=none)

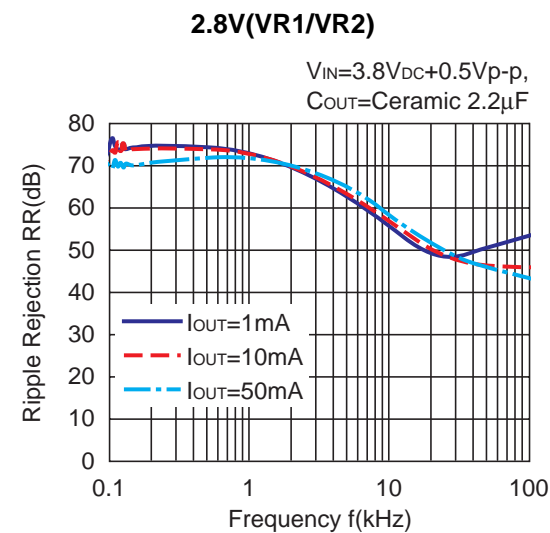
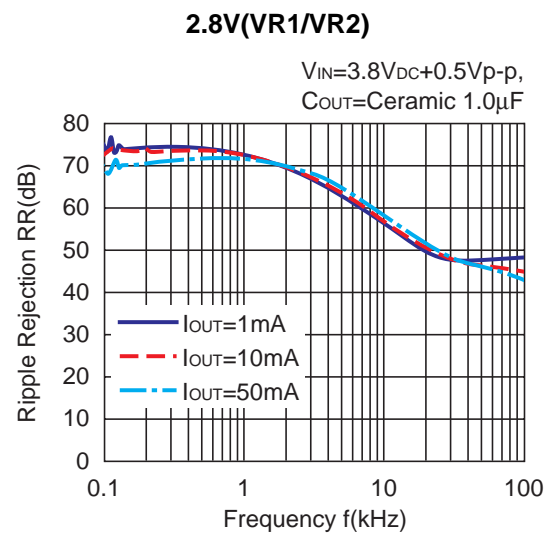
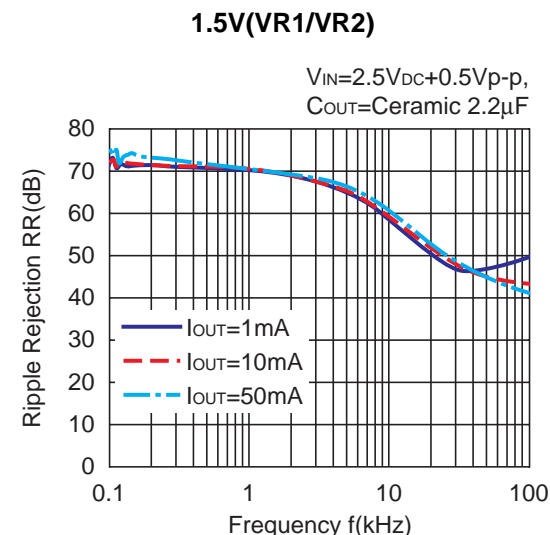
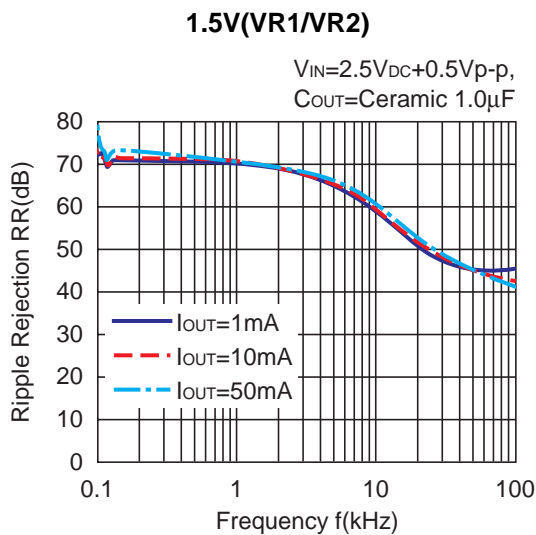
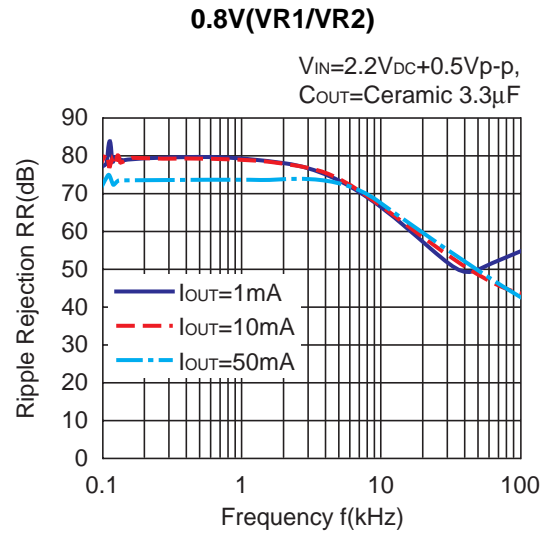
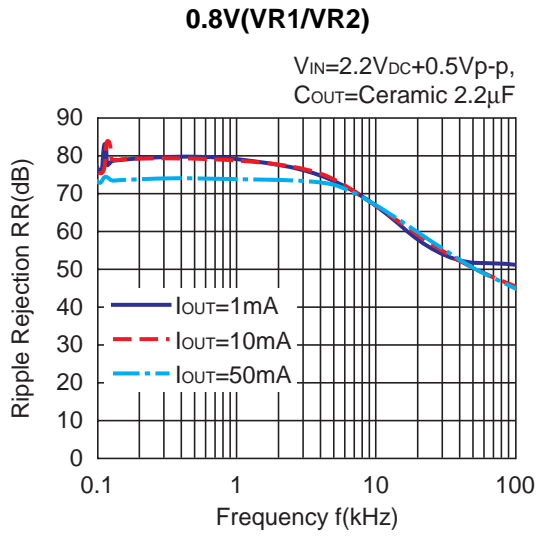

* R5326N (SOT-23-6) and R5326Z (WLCSP-6-P1) are the discontinued product. As of June in 2016.

R5326x

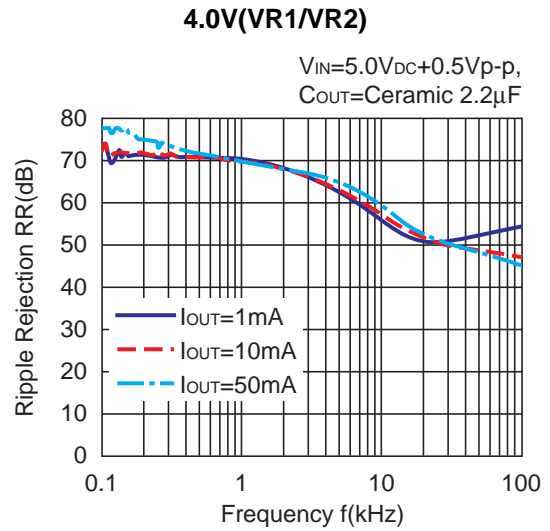
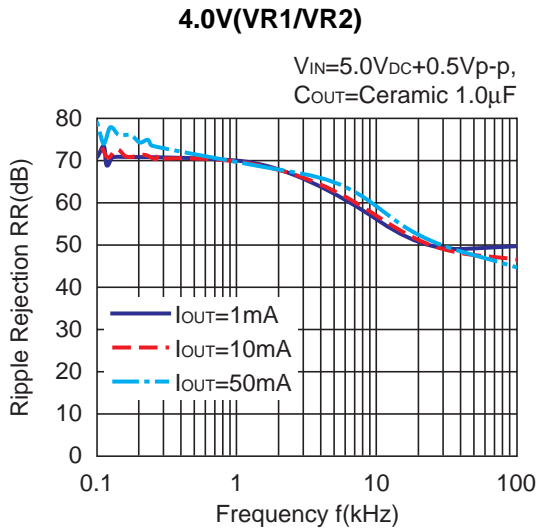

12) Input Transient Response ($I_{OUT}=30\text{mA}$, $t_r=t_f=5\mu\text{s}$, $C_{IN}=\text{none}$)

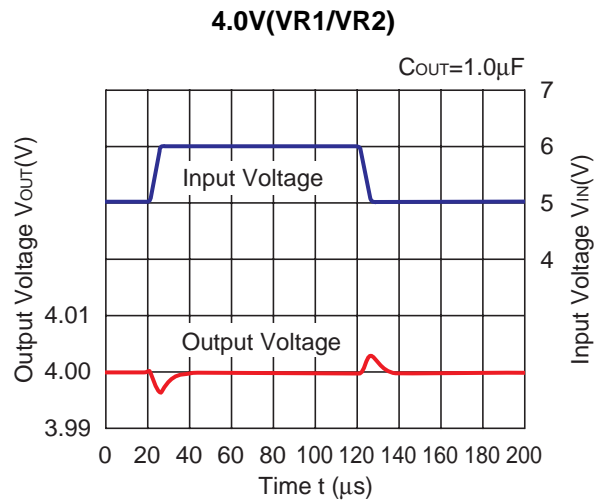
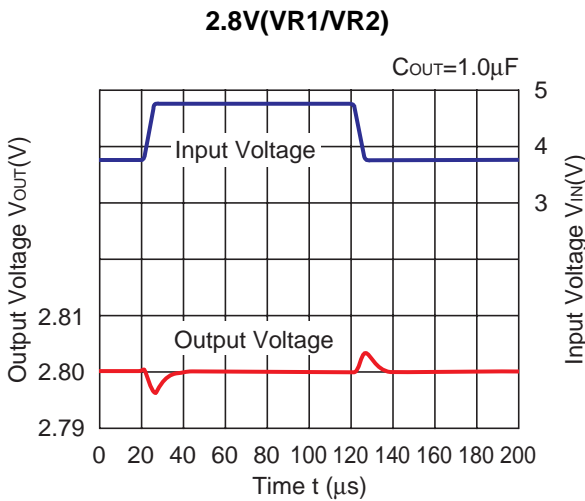
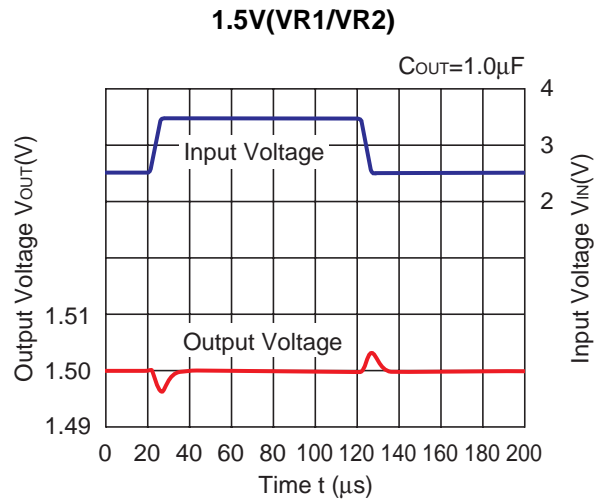
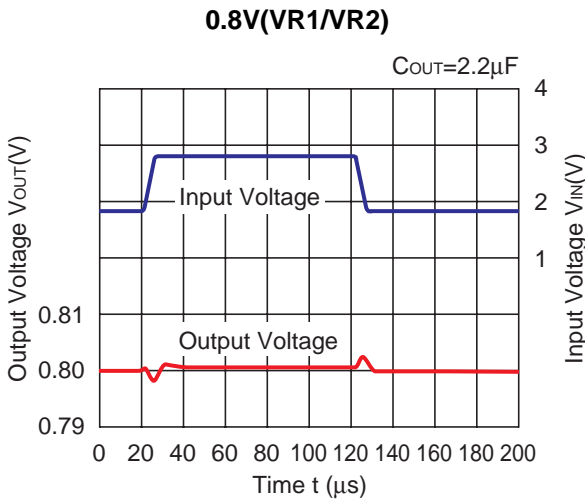

13) Load Transient Response1 ($t_r=t_f=0.5\mu s$, $C_{IN}=1.0\mu F$)

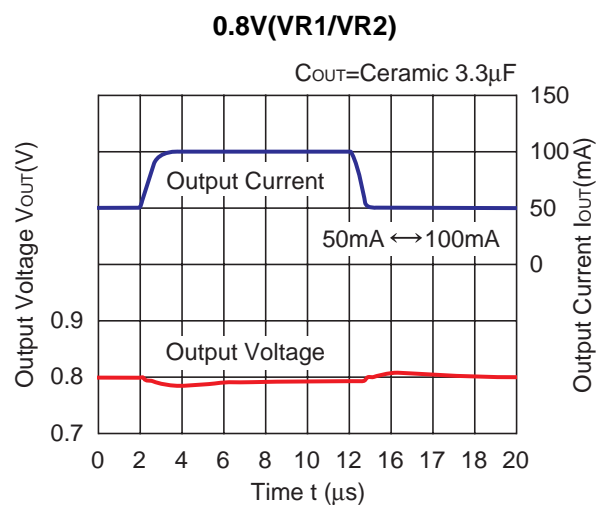
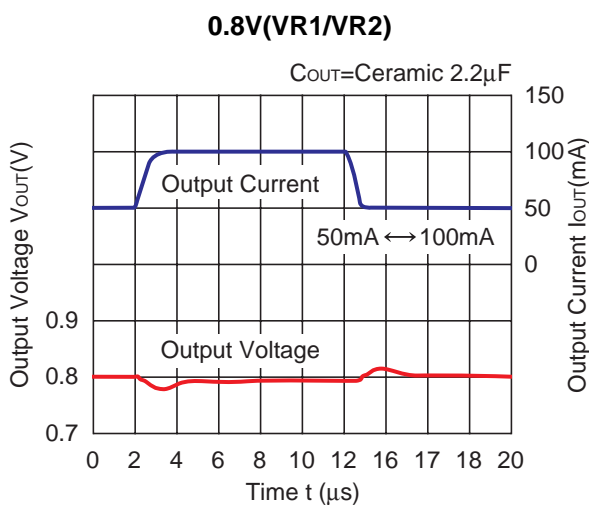
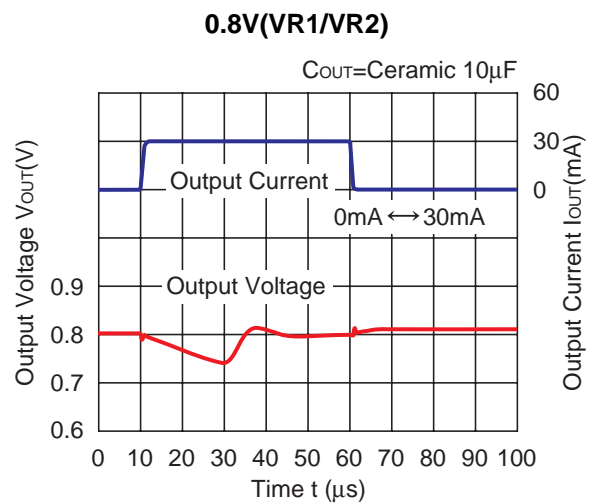
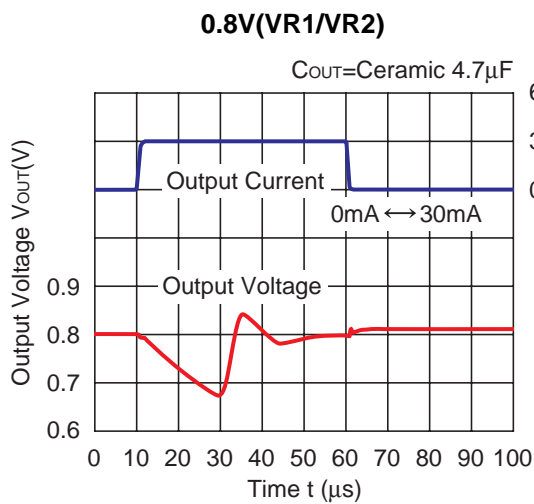
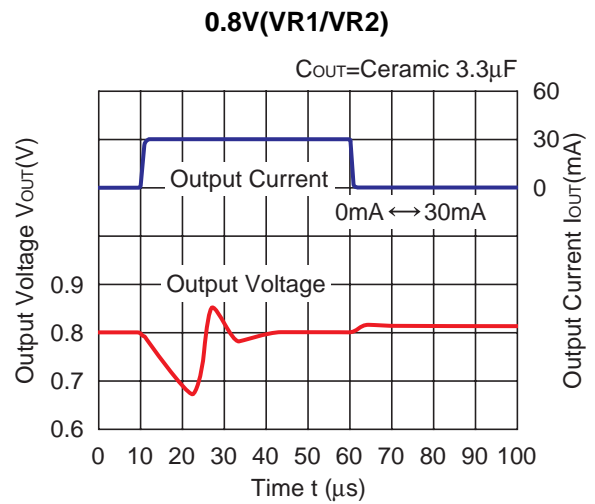
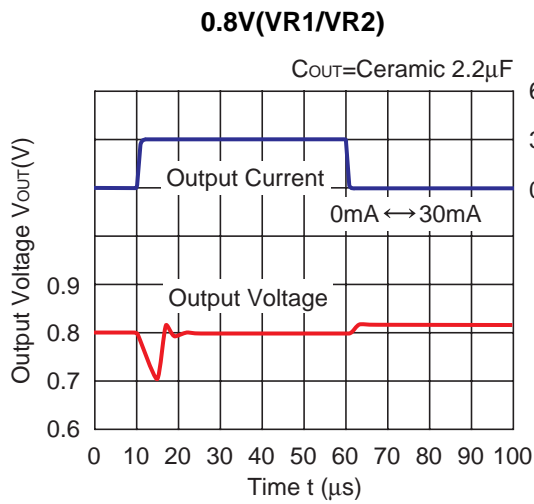

R5326x

1.5V (VR1/VR2)

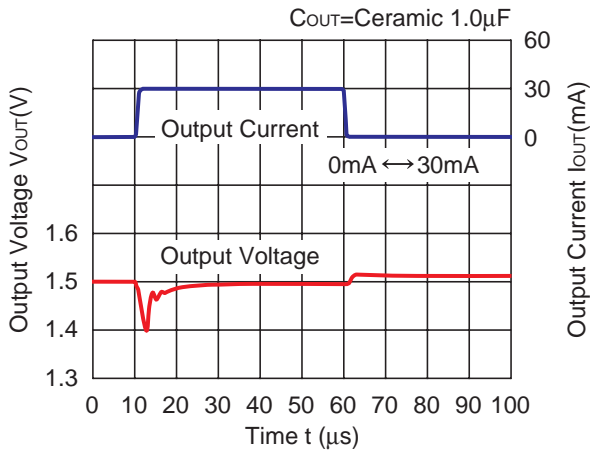

1.5V (VR1/VR2)

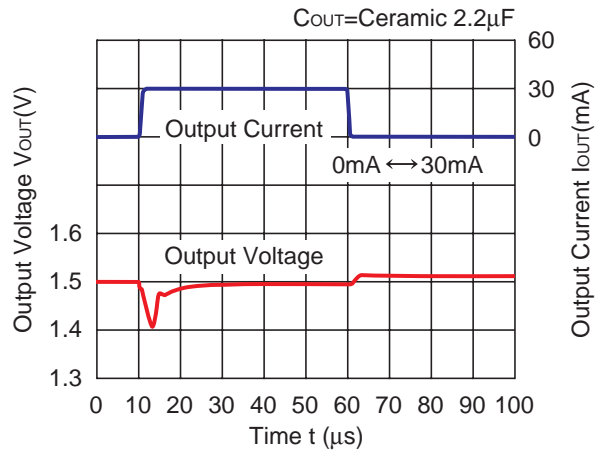

1.5V (VR1/VR2)

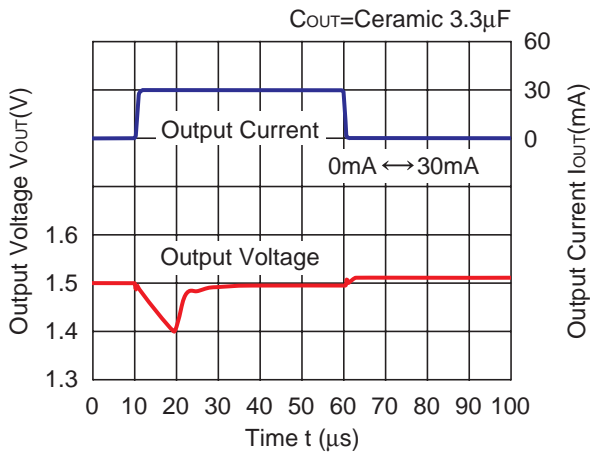

1.5V (VR1/VR2)

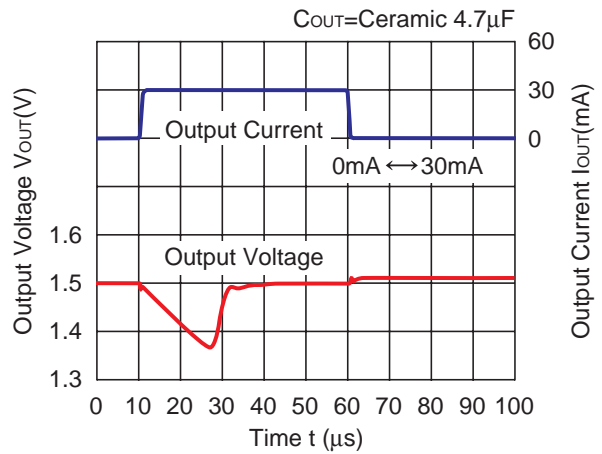

1.5V (VR1/VR2)

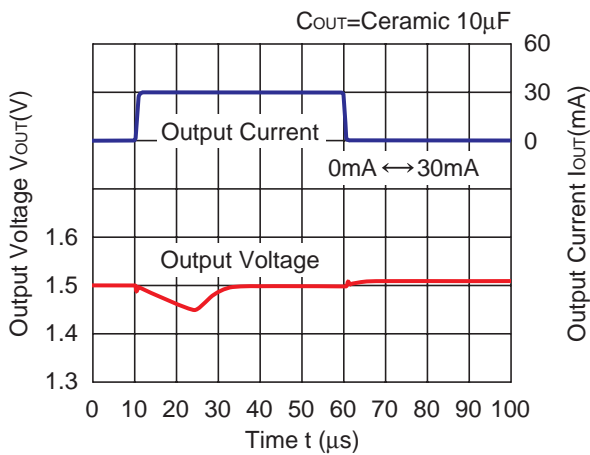

1.5V (VR1/VR2)

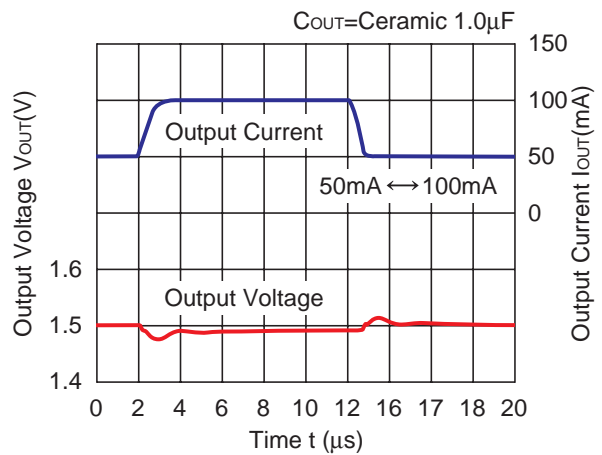

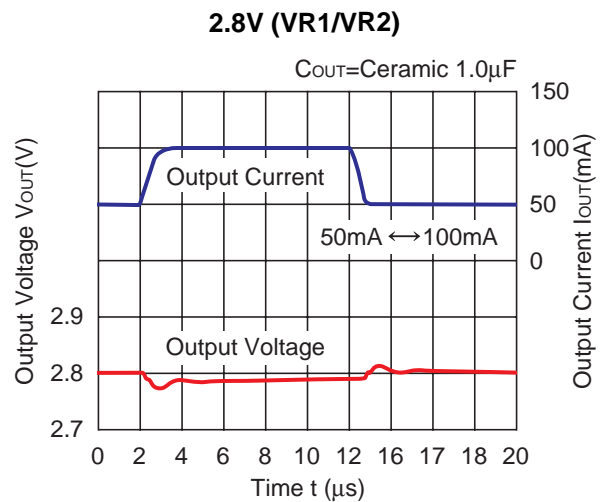
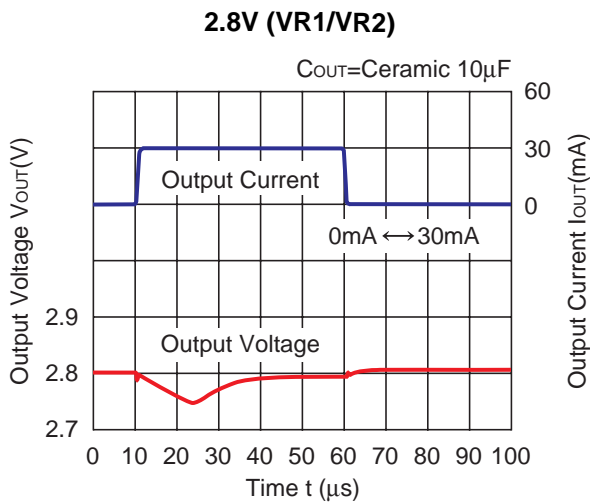
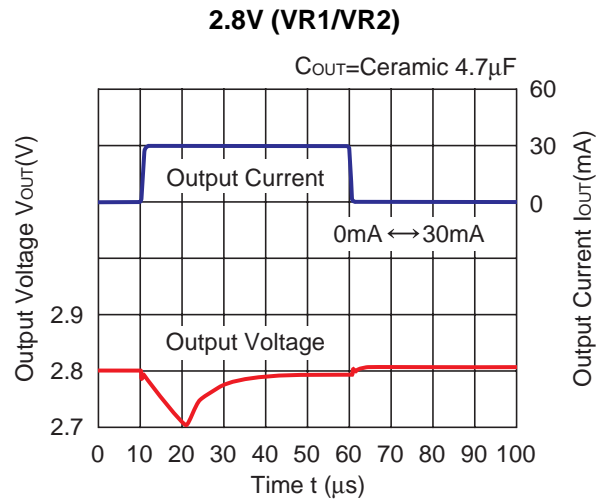
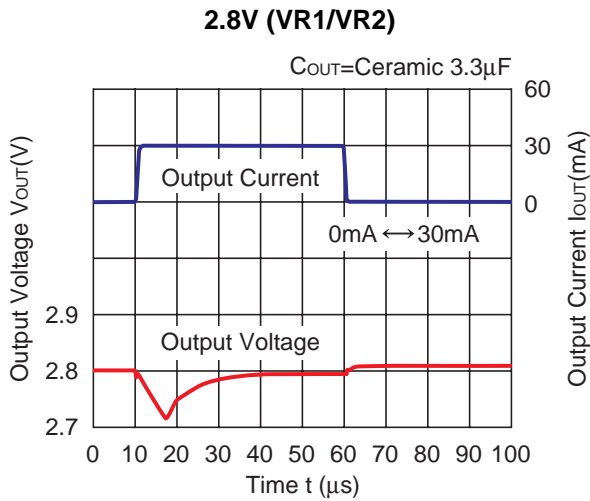
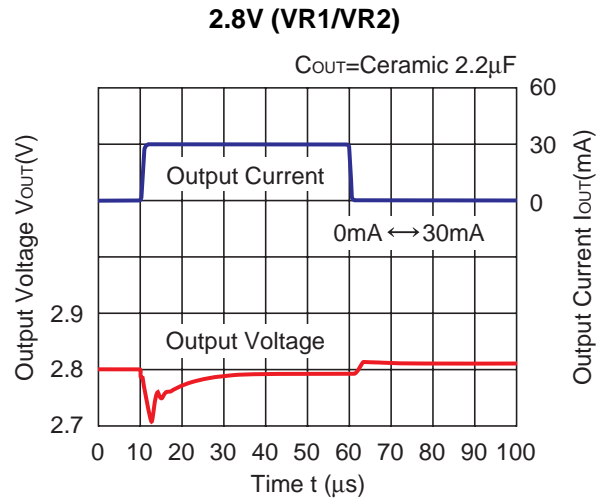
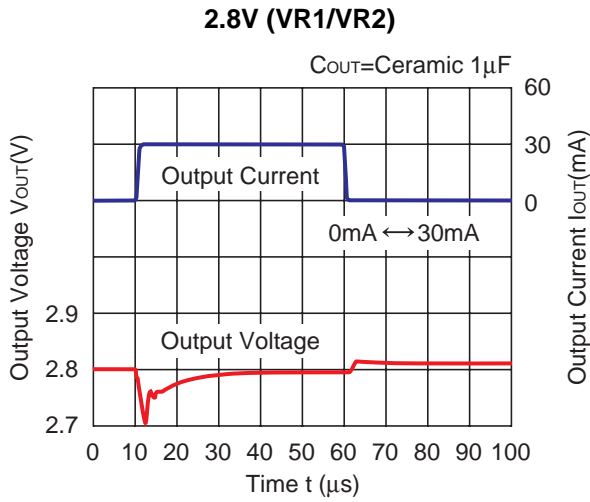

R5326x

4.0V (VR1/VR2)

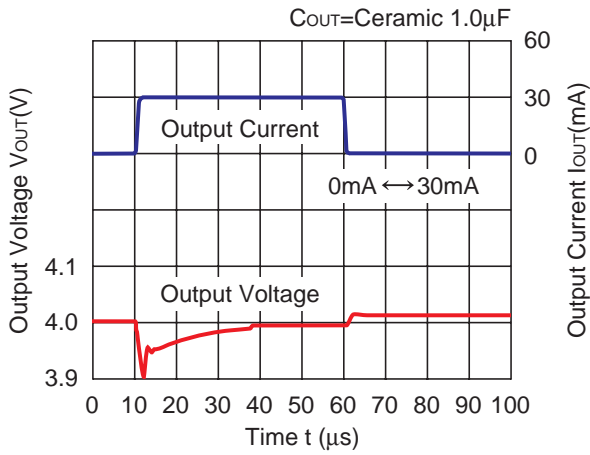

4.0V (VR1/VR2)

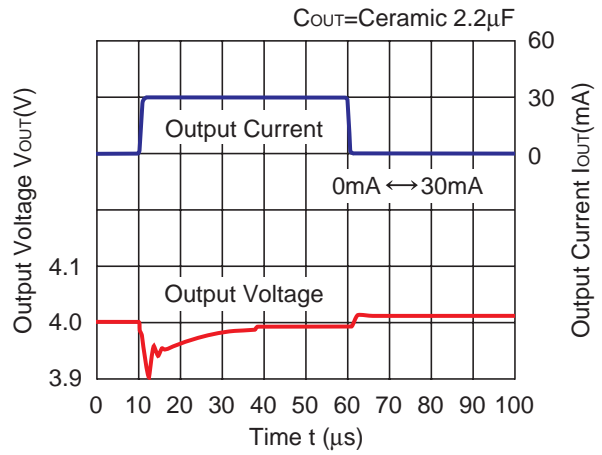

4.0V (VR1/VR2)

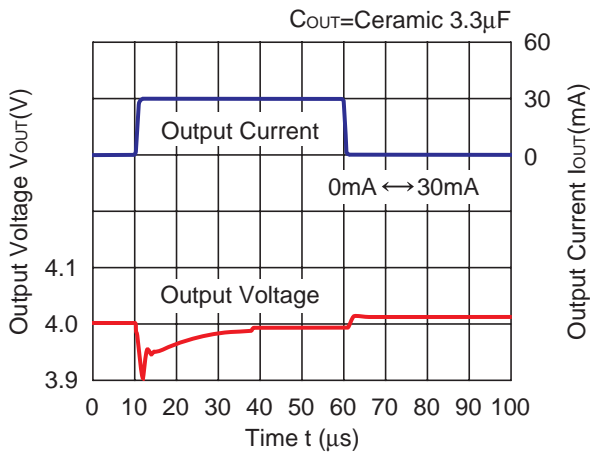

4.0V (VR1/VR2)

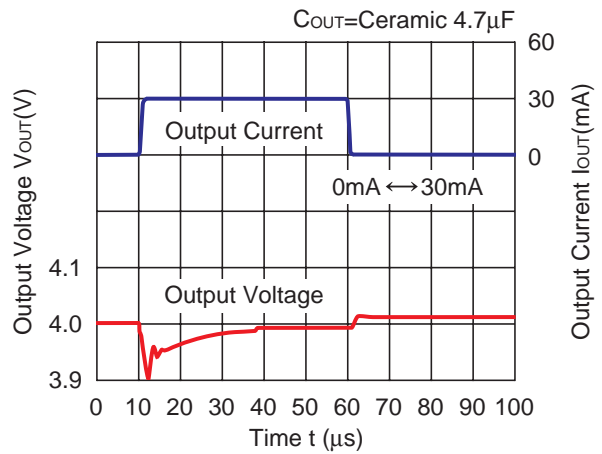

4.0V (VR1/VR2)

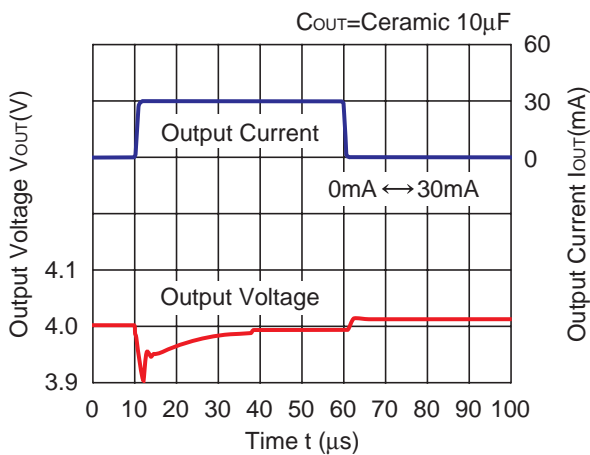

4.0V (VR1/VR2)

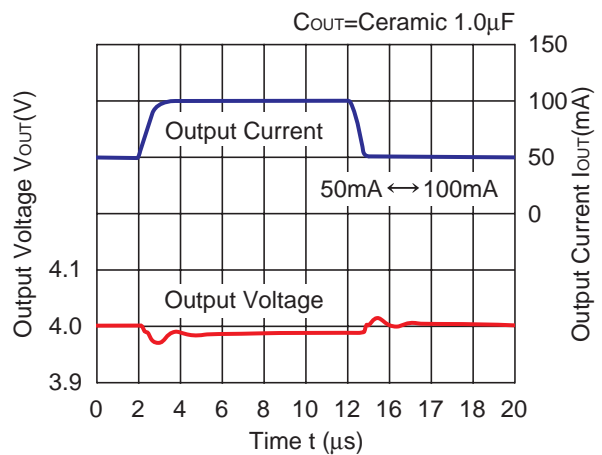

14) Load Transient Response2 ($t_r=t_f=0.5\mu s$, $C_{IN}=1.0\mu F$)

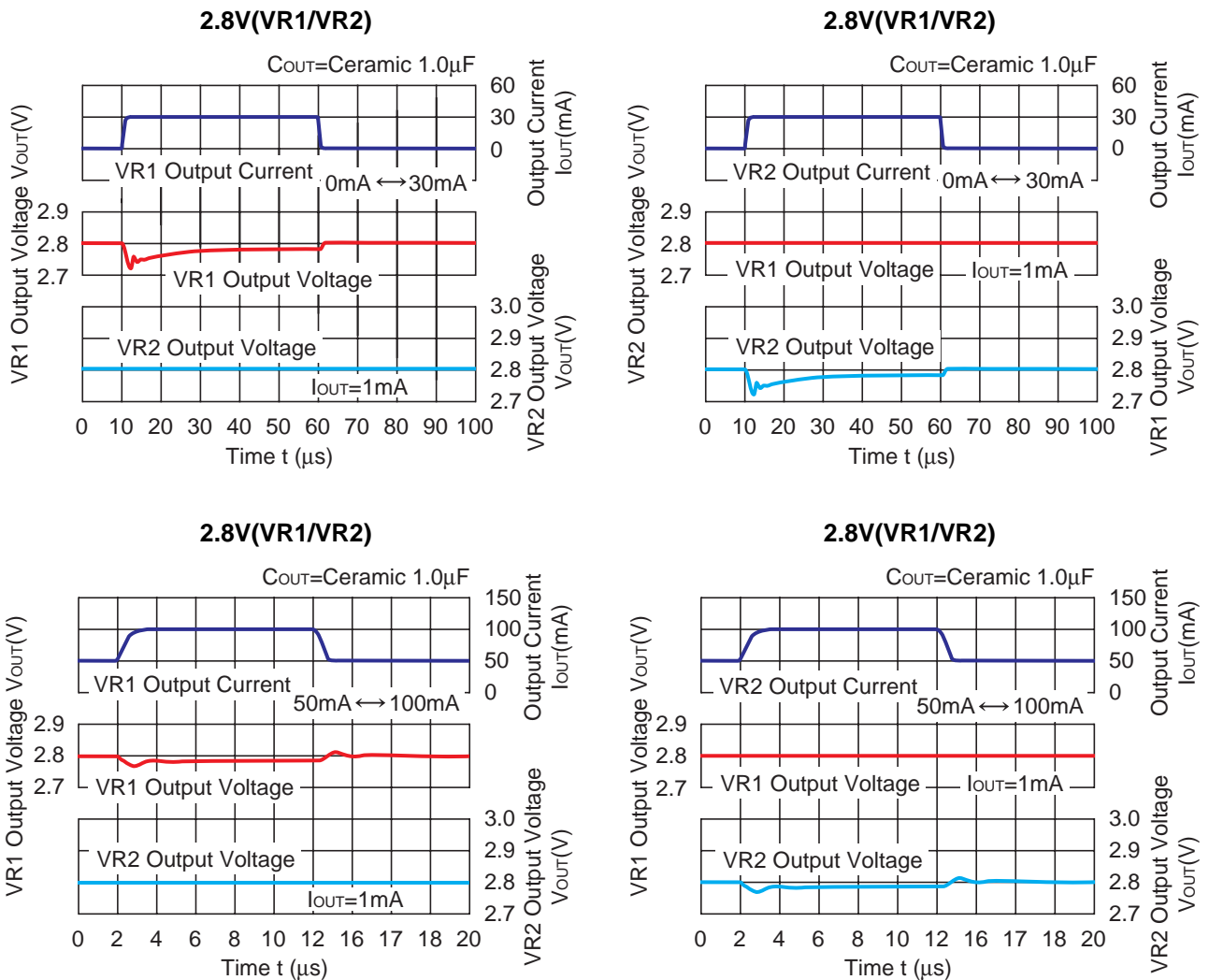

15) Load Transient Response3 ($t_r=t_f=10ns$)

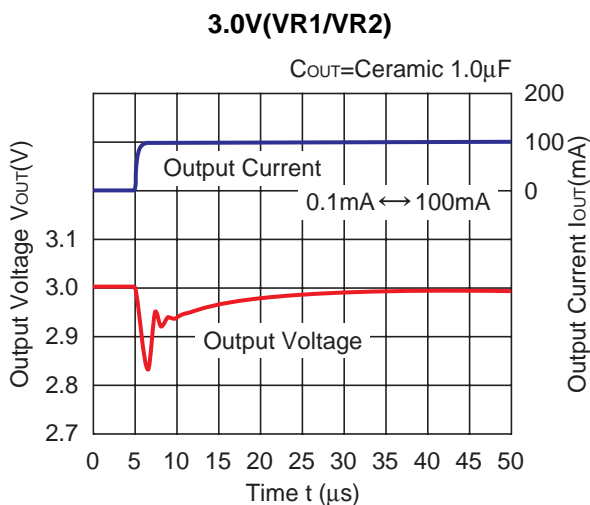

R5326x

16) Turn on speed with CE Pin (C_{IN} =Ceramic 1.0 μ F)

0.8V(VR1/VR2)

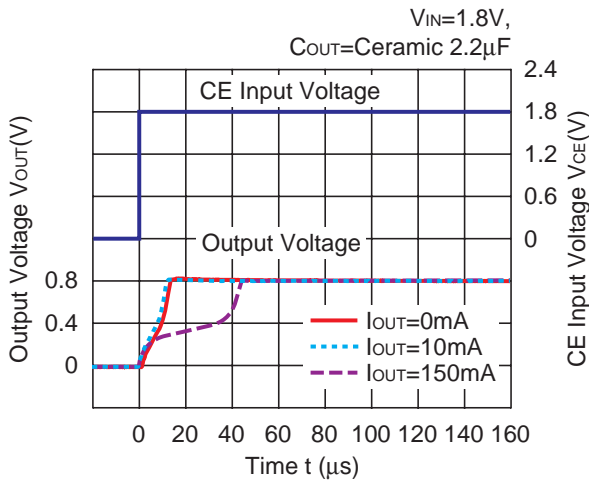

1.5V(VR1/VR2)

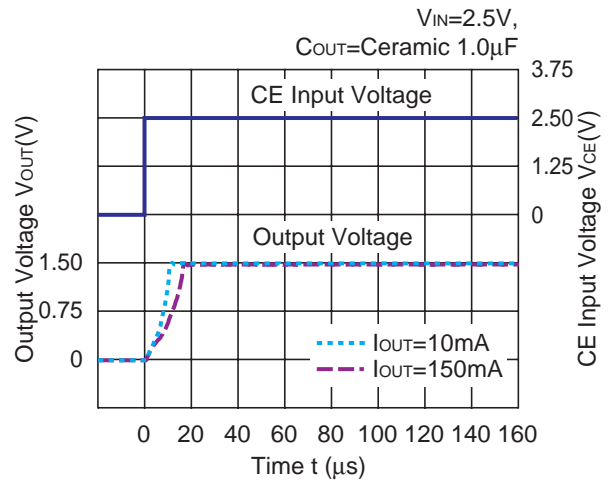

2.8V(VR1/VR2)

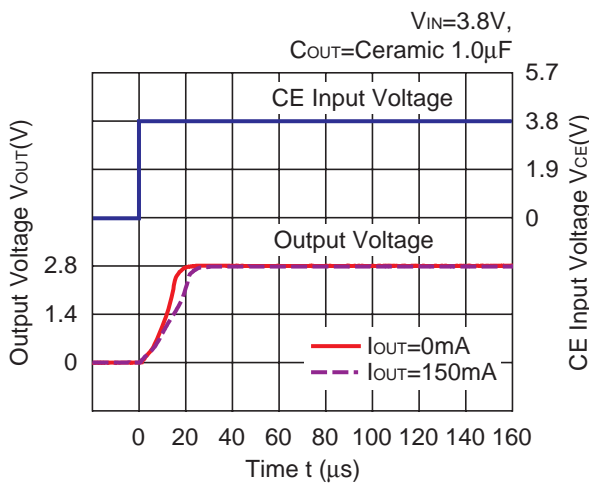

4.0V(VR1/VR2)

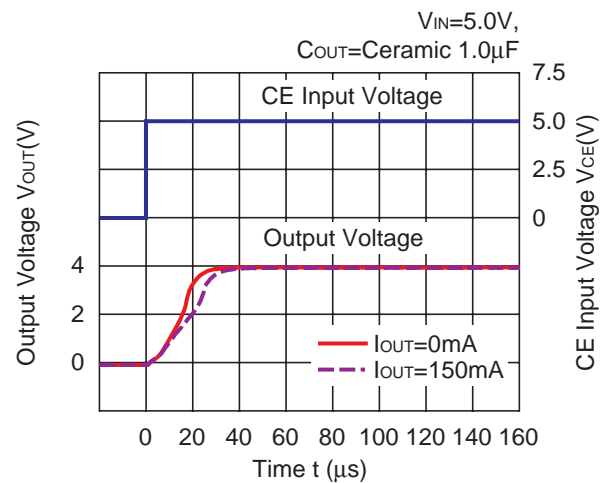

17) Turn off speed with CE Pin (C_{IN} =Ceramic 1.0 μ F)

0.8V(VR1/VR2)

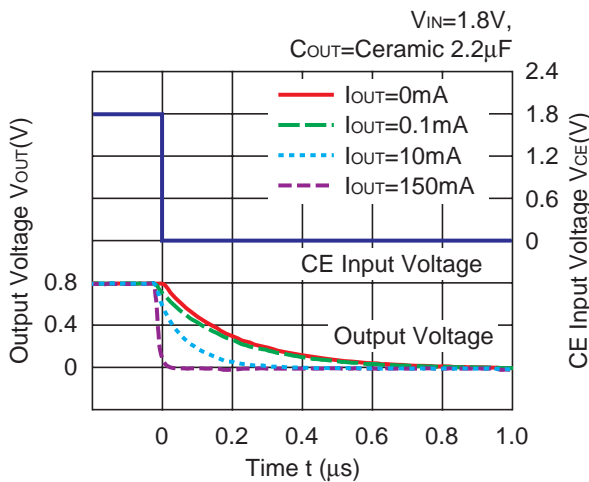

1.5V(VR1/VR2)

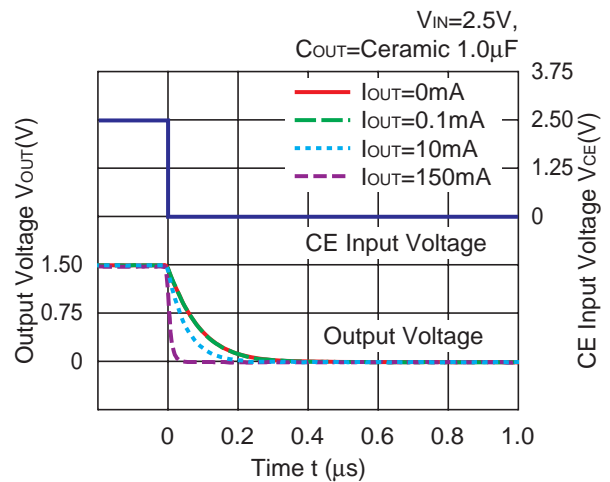

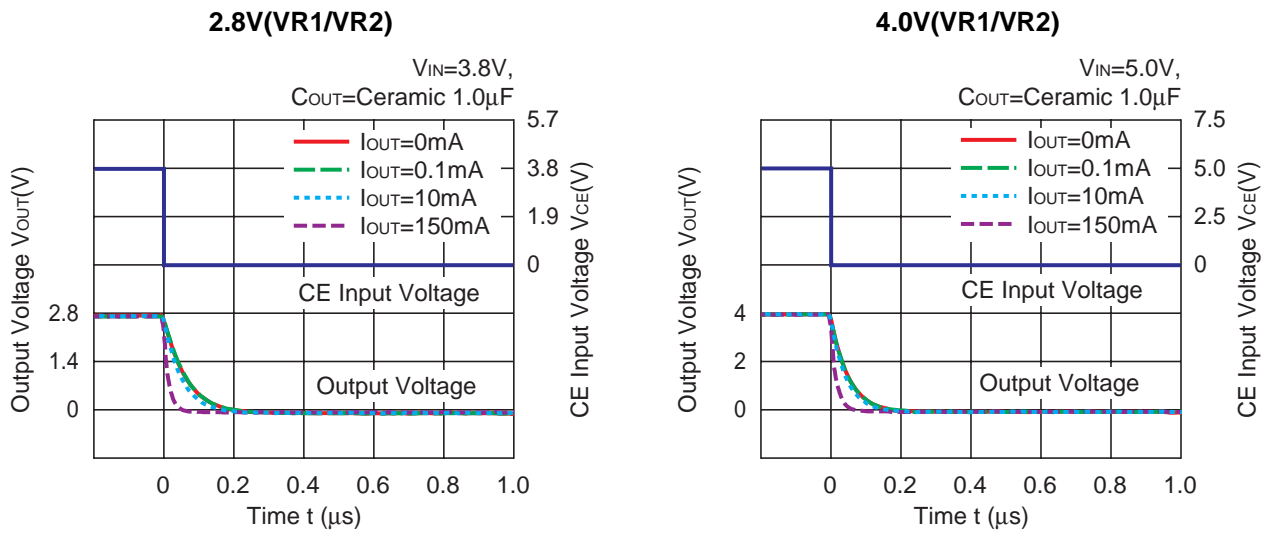

R5326x

ESR vs. Output Current

Ceramic type output capacitor is recommended for this series; however, the other output capacitors with low ESR also can be used. The relations between I_{OUT} (Output Current) and ESR of an output capacitor are shown below. The conditions when the white noise level is under $40\mu\text{V}$ (Avg.) are marked as the hatched area in the graph

Measurement conditions

Frequency Band : 10Hz to 2MHz

Temperature : -40°C to 85°C

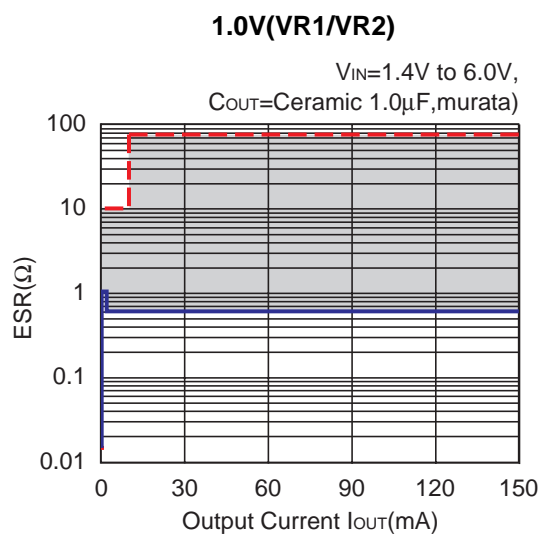
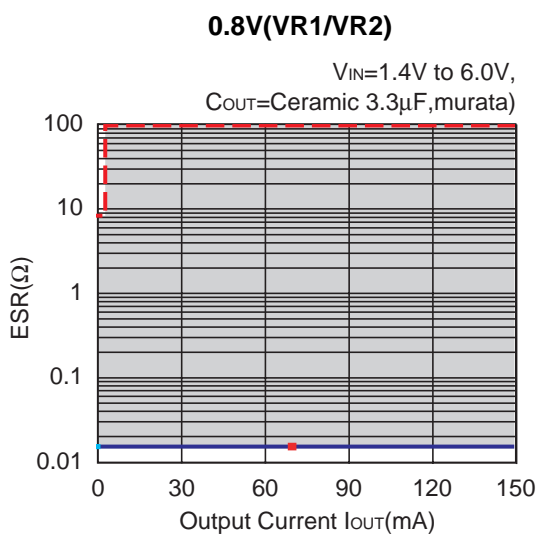
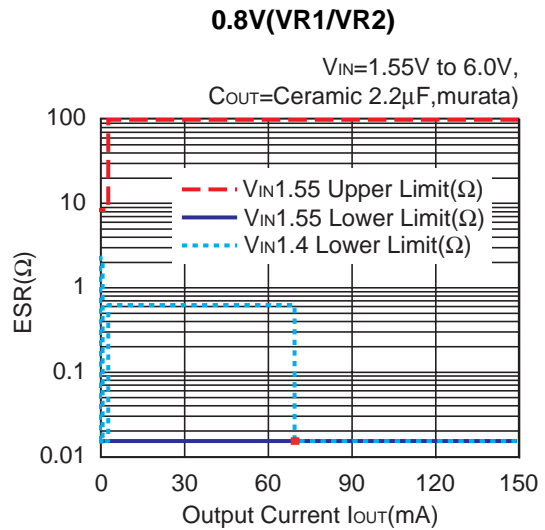
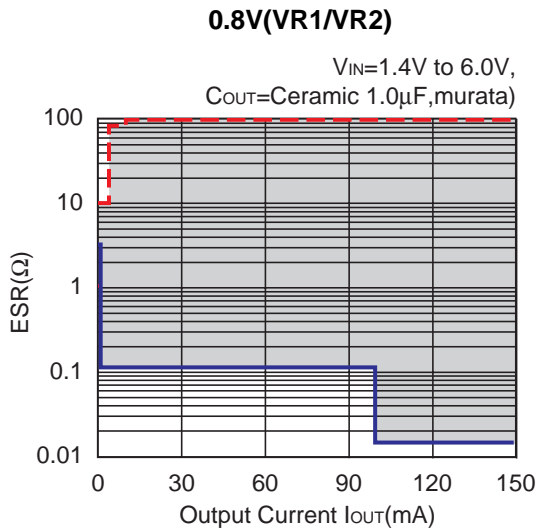

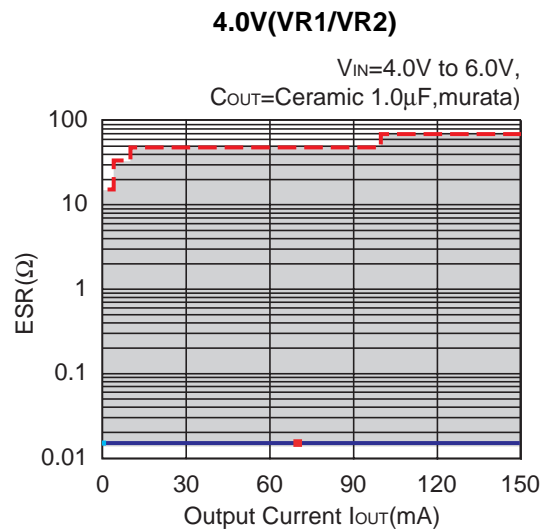
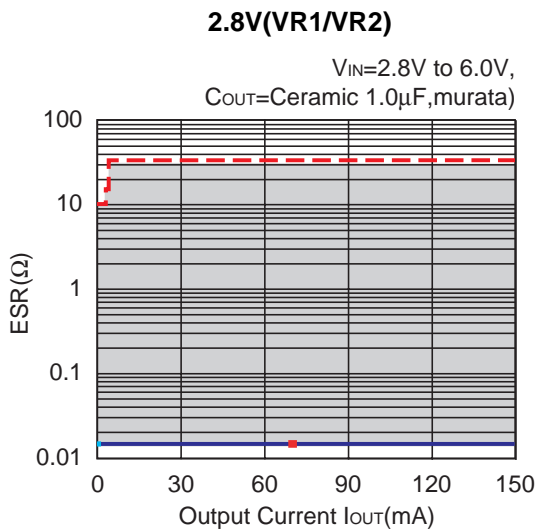
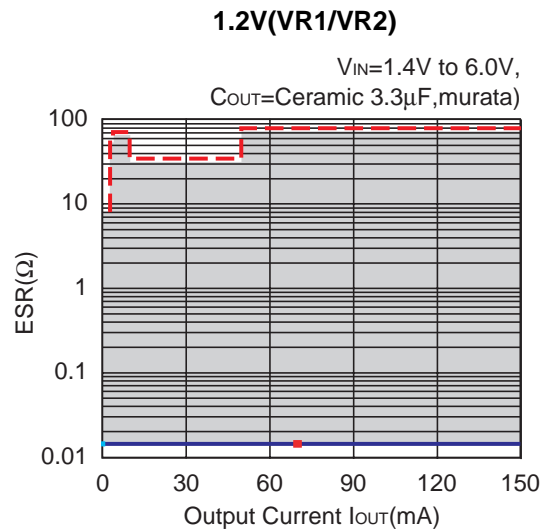
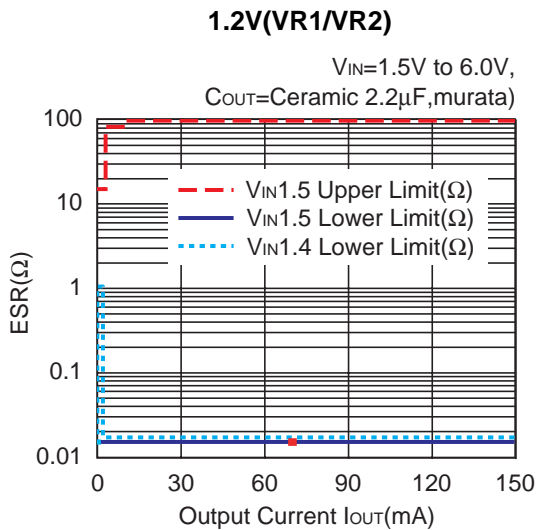
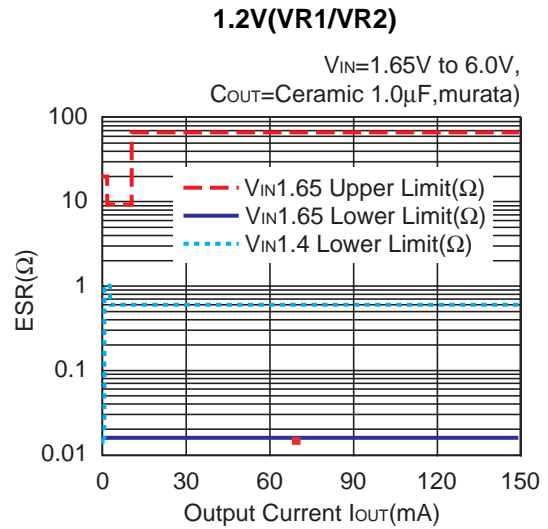
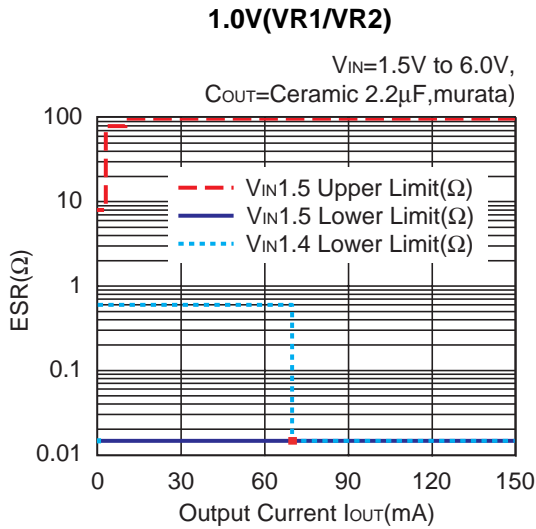

* R5326N (SOT-23-6) and R5326Z (WLCSP-6-P1) are the discontinued product. As of June in 2016.

R5326x

0.8V(VR1/VR2)

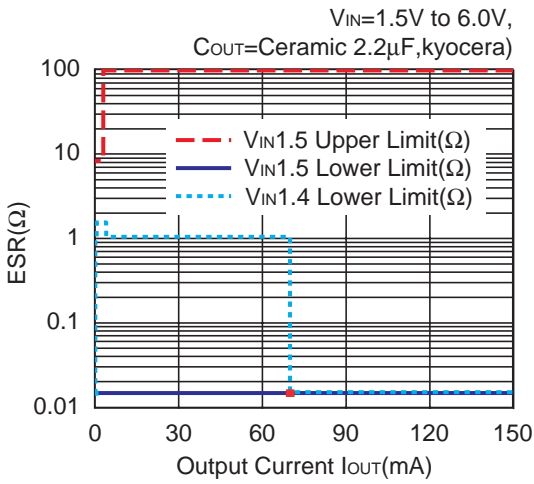

1.0V(VR1/VR2)

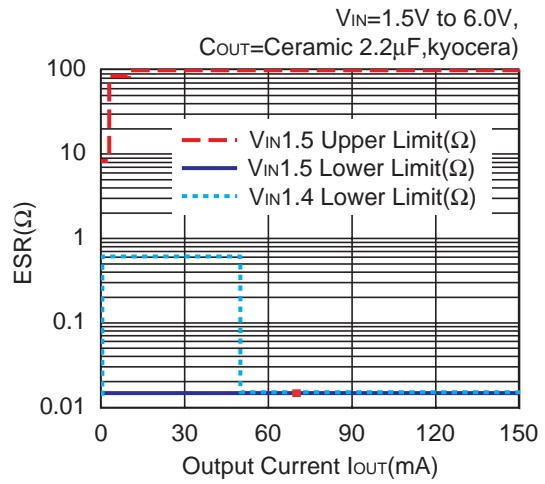

1.2V(VR1/VR2)

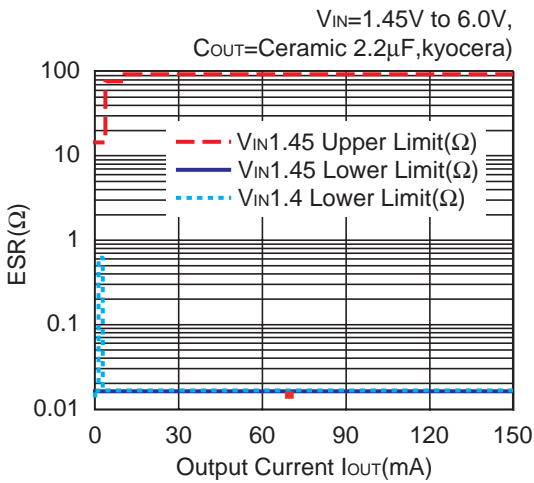



1. The products and the product specifications described in this document are subject to change or discontinuation of production without notice for reasons such as improvement. Therefore, before deciding to use the products, please refer to Ricoh sales representatives for the latest information thereon.
2. The materials in this document may not be copied or otherwise reproduced in whole or in part without prior written consent of Ricoh.
3. Please be sure to take any necessary formalities under relevant laws or regulations before exporting or otherwise taking out of your country the products or the technical information described herein.
4. The technical information described in this document shows typical characteristics of and example application circuits for the products. The release of such information is not to be construed as a warranty of or a grant of license under Ricoh's or any third party's intellectual property rights or any other rights.
5. The products listed in this document are intended and designed for use as general electronic components in standard applications (office equipment, telecommunication equipment, measuring instruments, consumer electronic products, amusement equipment etc.). Those customers intending to use a product in an application requiring extreme quality and reliability, for example, in a highly specific application where the failure or misoperation of the product could result in human injury or death (aircraft, spacevehicle, nuclear reactor control system, traffic control system, automotive and transportation equipment, combustion equipment, safety devices, life support system etc.) should first contact us.
6. We are making our continuous effort to improve the quality and reliability of our products, but semiconductor products are likely to fail with certain probability. In order to prevent any injury to persons or damages to property resulting from such failure, customers should be careful enough to incorporate safety measures in their design, such as redundancy feature, fire containment feature and fail-safe feature. We do not assume any liability or responsibility for any loss or damage arising from misuse or inappropriate use of the products.
7. Anti-radiation design is not implemented in the products described in this document.
8. Please contact Ricoh sales representatives should you have any questions or comments concerning the products or the technical information.



Ricoh is committed to reducing the environmental loading materials in electrical devices with a view to contributing to the protection of human health and the environment.

Ricoh has been providing RoHS compliant products since April 1, 2006 and Halogen-free products since April 1, 2012.

RICOH RICOH ELECTRONIC DEVICES CO., LTD.

<http://www.e-devices.ricoh.co.jp/en/>

Sales & Support Offices

RICOH ELECTRONIC DEVICES CO., LTD.

Higashi-Shinagawa Office (International Sales)
3-32-3, Higashi-Shinagawa, Shinagawa-ku, Tokyo 140-8655, Japan
Phone: +81-3-5479-2857 Fax: +81-3-5479-0502

RICOH EUROPE (NETHERLANDS) B.V.

Semiconductor Support Centre
Prof. W.H. Keesomlaan 1, 1183 DJ Amstelveen, The Netherlands
Phone: +31-20-5474-309

RICOH INTERNATIONAL B.V. - German Branch

Semiconductor Sales and Support Centre
Oberrather Strasse 6, 40472 Düsseldorf, Germany
Phone: +49-211-6546-0

RICOH ELECTRONIC DEVICES KOREA CO., LTD.

3F, Haesung Bldg, 504, Teheran-ro, Gangnam-gu, Seoul, 135-725, Korea
Phone: +82-2-2135-5700 Fax: +82-2-2051-5713

RICOH ELECTRONIC DEVICES SHANGHAI CO., LTD.

Room 403, No.2 Building, No.690 Bibo Road, Pu Dong New District, Shanghai 201203, People's Republic of China
Phone: +86-21-5027-3200 Fax: +86-21-5027-3299

RICOH ELECTRONIC DEVICES CO., LTD.

Taipei office
Room 109, 10F-1, No.51, Hengyang Rd., Taipei City, Taiwan (R.O.C.)
Phone: +886-2-2313-1621/1622 Fax: +886-2-2313-1623