

**PLEASE CHECK WWW.MOLEX.COM FOR LATEST PART INFORMATION**

**Part Number:** **0760151125**  
**Status:** **Active**  
**Overview:** [gbx itrac backplane connector system](#)  
**Description:** 1.85mm by 3.70mm (.073" by .146") Pitch, GbX I-Trac™ Vertical Header Module, Unguided, Dual End Walls, 7 Rows, 10 Columns, 140 Circuits, Staggered Mating Pin Length 4.70mm (.185") & 5.70mm (.224"), Lead Free

**Documents:**

[3D Model](#) [Product Specification PS-75710-999 \(PDF\)](#)  
[Drawing \(PDF\)](#) [RoHS Certificate of Compliance \(PDF\)](#)

**Agency Certification**

UL E29179

**General**

Product Family Backplane Connectors  
 Series [76015](#)  
 Application Backplane, Midplane, Orthogonal  
 Application Tooling Documents [http://www.molex.com/pdm\\_docs/ats/ATS-622018699.pdf](http://www.molex.com/pdm_docs/ats/ATS-622018699.pdf)>Tooling Manual</a>  
 Component Type PCB Header  
 More Detailed Tech Information [I-Trac@molex.com](mailto:I-Trac@molex.com)  
 Overview [gbx itrac backplane connector system](#)  
 Product Name GbX I-Trac™  
 Style N/A

**Physical**

Circuits (Loaded) 140  
 Circuits (maximum) 140  
 Color - Resin Black  
 Durability (mating cycles max) 200  
 First Mate / Last Break Yes  
 Flammability 94V-0  
 Guide to Mating Part No  
 Keying to Mating Part None  
 Material - Metal High Performance Alloy (HPA)  
 Material - Plating Mating Gold  
 Material - Plating Termination Tin  
 Material - Resin High Temperature Thermoplastic  
 Number of Columns 10  
 Number of Pairs 4, Open Pin Field  
 Number of Rows 7  
 Orientation Vertical  
 PC Tail Length (in) 0.083 In  
 PC Tail Length (mm) 2.10 mm  
 PCB Locator No  
 PCB Retention None  
 PCB Thickness Recommended (in) 0.063 In  
 PCB Thickness Recommended (mm) 1.60 mm  
 Packaging Type Tray  
 Pitch - Mating Interface (in) 0.073 In, 0.146 In  
 Pitch - Mating Interface (mm) 1.85 mm, 3.70 mm  
 Pitch - Term. Interface (in) 0.039 In, 0.106 In  
 Pitch - Term. Interface (mm) 1.00 mm, 2.70 mm  
 Plating min: Mating (µin) 30.4  
 Plating min: Mating (µm) 0.76

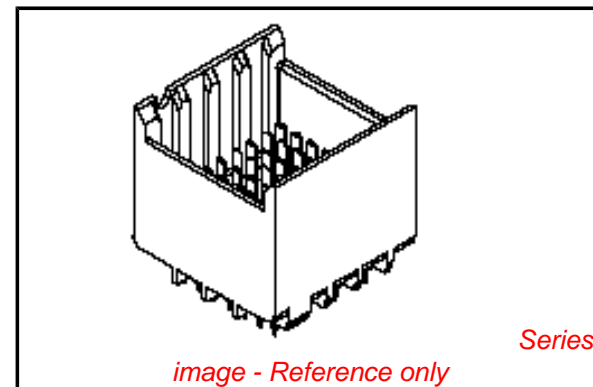

**EU RoHS**

**ELV and RoHS Compliant**  
**REACH SVHC Contains SVHC: No**  
**Halogen-Free Status**  
**Not Reviewed**

**China RoHS**



**Need more information on product environmental compliance?**

Email [productcompliance@molex.com](mailto:productcompliance@molex.com)  
 For a multiple part number RoHS Certificate of Compliance, [click here](#)

Please visit the [Contact Us](#) section for any non-product compliance questions.

**Search Parts in this Series**

[76015Series](#)

**Mates With**

[76020](#) GbX I-Trac™ Right Angle Receptacle Module

**Use With**

[78227](#) GbX I-Trac™ Vertical Power Receptacle. [75234](#) Backplane Free Standing Guide Pin

**Application Tooling | FAQ**

*Tooling specifications and manuals are found by selecting the products below. Crimp Height Specifications are then contained in the Application Tooling Specification document.*

**Global**

Description	Product #
Press-In Tool, GbX I-Trac™ Vertical Header 7 Row, 10 Column	<a href="#">0622018609</a>

Plating min: Termination ( $\mu$ in)	30.4
Plating min: Termination ( $\mu$ m)	0.76
Polarized to PCB	No
Stackable	Yes
Surface Mount Compatible (SMC)	Yes
Temperature Range - Operating	85°C
Termination Interface: Style	Through Hole - Compliant Pin

Backplane Insertion <a href="#">0621005110</a>
Tool, GbX I-Trac™
Signal Contact
Insertion

### Electrical

Current - Maximum per Contact	1A
Data Rate	12.0 Gbps
Shield Type	N/A
Shielded	No
Voltage - Maximum	120V AC (RMS)/DC

### Material Info

#### Reference - Drawing Numbers

Packaging Specification	PK-70873-802
Product Specification	PS-75710-999
Sales Drawing	SD-76015-001

This document was generated on 05/14/2010

**PLEASE CHECK [WWW.MOLEX.COM](http://WWW.MOLEX.COM) FOR LATEST PART INFORMATION**

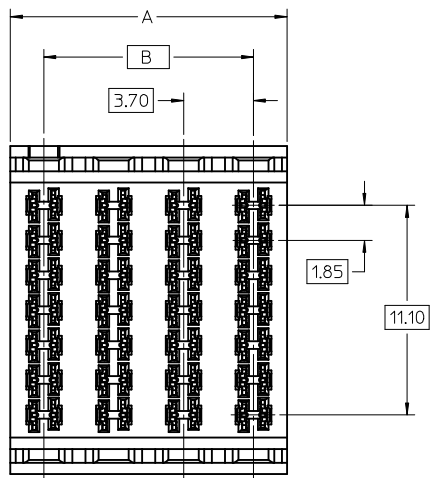

76015-\*\*\*\*

MODULE TYPE -- TAIL PLATING TYPE  
 UNGUIDED -- TIN/LEAD = 0  
 UNGUIDED -- TIN ONLY = 1

# OF COLUMNS  
 4 = 4 COL  
 6 = 6 COL  
 1 = 10 COL

PIN LENGTH (P)  
 2 = 3.90  
 3 = 4.70  
 4 = 5.70

PART STYLE  
 0 = OPEN ENDS  
 1 = LEFT END WALL STAGGERED  
 2 = DUAL END WALL  
 3 = RIGHT END WALL

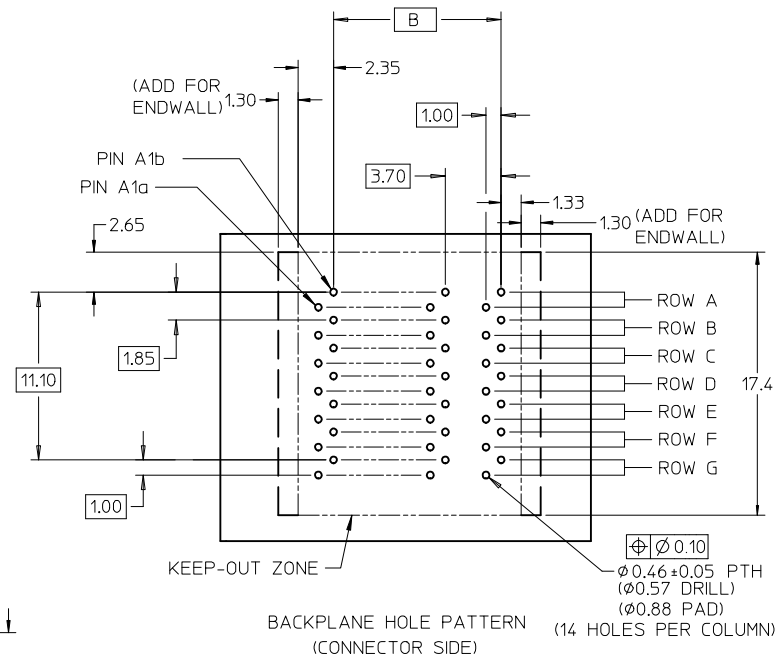
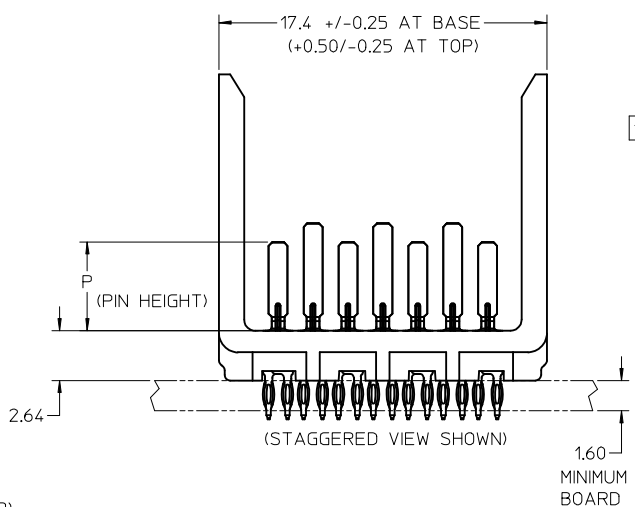
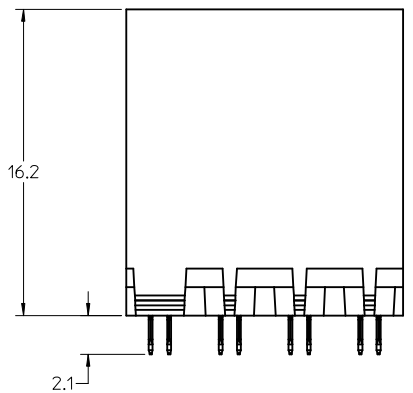

- NOTES:
- MATERIALS: HOUSING - LIQUID CRYSTAL POLYMER (LCP)  
GLASS-FILLED, UL94V-0  
TERMINALS - HIGH PERFORMANCE COPPER ALLOY
  - FINISH: 30uIN MIN. GOLD IN CONTACT AREA.  
SELECTIVE TIN/LEAD OR SELECTIVE TIN ON PCB TAILS. NICKEL OVERALL.
  - REFER TO MOLEX PRODUCT SPECIFICATION PS-75710-999 FOR PERFORMANCE SPECIFICATIONS.
  - FOR MIXED CONTACT MATING LENGTHS, CONSULT MOLEX FOR AVAILABILITY.
  - THIS PART CONFORMS TO CLASS B REQUIREMENTS OF MOLEX COSMETIC SPEC PS-45499-002
  - PACKAGE PER: PK-70873-802.
  - REFER TO PCB ROUTING GUIDE FOR ANTIPAD AND ROUTING RECOMMENDATIONS.

REVISE SHEETS 3 & 4 EC NO: UCP2009-2507 DRWNG: STEWART 2009/04/16 CHKD: BINGHAM 2009/04/17 APPR: BINGHAM 2009/04/17	DESCRIPTION I-TRAC BACKPLANE 7 ROW UNGUIDED ASSEMBLY SALES DRAWING	QUALITY SYMBOLS		GENERAL TOLERANCES (UNLESS SPECIFIED)		DIMENSION STYLE MM ONLY		SCALE 5:1	DESIGN UNITS METRIC	THIRD ANGLE PROJECTION	
		▽=0 ▽=0		mm INCH 4 PLACES ± --- ± --- 3 PLACES ± --- ± --- 2 PLACES ± 0.13 ± --- 1 PLACE ± 0.25 ± ---		DRAWN BY DATE BPISZCZOR 2007/01/25 CHECKED BY DATE JLAURX 2007/02/06 APPROVED BY DATE CBIXLER 2007/02/06		TITLE I-TRAC BACKPLANE 7 ROW UNGUIDED ASSEMBLY SALES DRAWING			
		ANGULAR ±1/2°		DRAFT WHERE APPLICABLE MUST REMAIN WITHIN DIMENSIONS		SEE CHART		MATERIAL NO.		DOCUMENT NO.	
						SIZE C		THIS DRAWING CONTAINS INFORMATION THAT IS PROPRIETARY TO MOLEX INCORPORATED AND SHOULD NOT BE USED WITHOUT WRITTEN PERMISSION		SHEET NO. 1 OF 4	

MATERIAL NUMBER	# OF COLUMNS	DIM "A"	DIM "B"
76015-*42*	4	17.3	11.10
76015-*62*	6	24.7	18.50
76015-*12*	10	39.5	33.30

DUAL END STYLE

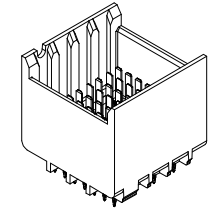

MATERIAL NUMBER	# OF COLUMNS	DIM "A"	DIM "B"
76015-*41*	4	16.0	11.10
76015-*61*	6	23.4	18.50
76015-*11*	10	38.2	33.30

LEFT END STYLE

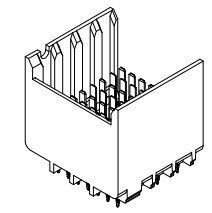

MATERIAL NUMBER	# OF COLUMNS	DIM "A"	DIM "B"
76015-*43*	4	16.0	11.10
76015-*63*	6	23.4	18.50
76015-*13*	10	38.2	33.30

RIGHT END STYLE

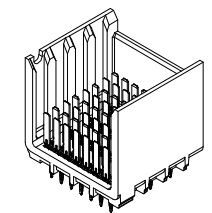

MATERIAL NUMBER	# OF COLUMNS	DIM "A"	DIM "B"
76015-*40*	4	14.7	11.10
76015-*60*	6	22.1	18.50
76015-*10*	10	36.9	33.30

OPEN END STYLE

NOTCH DESIGNATES ROW A

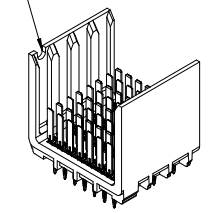

SEE SHEET ONE EC NO: UCP2009-2507 DRWNC: STEWART 2009/04/16 CHKD: BINGHAM 2009/04/17 APPR: BINGHAM 2009/04/17	QUALITY SYMBOLS ▽=0 ▽=0	GENERAL TOLERANCES (UNLESS SPECIFIED)		DIMENSION STYLE <b>MM ONLY</b>		SCALE 4:1	DESIGN UNITS METRIC	THIRD ANGLE PROJECTION			
		4 PLACES ± --- ± ---	3 PLACES ± --- ± ---	2 PLACES ± 0.13 ± ---	1 PLACE ± 0.25 ± ---	DRAWN BY BPISZCZOR	DATE 2007/01/25	TITLE I-TRAC BACKPLANE 7 ROW UNGUIDED ASSEMBLY SALES DRAWING			
		ANGULAR ±1/2°				CHECKED BY JLAURX	DATE 2007/02/06	APPROVED BY CBIXLER			
		DRAFT WHERE APPLICABLE MUST REMAIN WITHIN DIMENSIONS				MATERIAL NO. SEE CHART		DOCUMENT NO. SD-76015-001	SHEET NO. 2 OF 4		

THIS DRAWING CONTAINS INFORMATION THAT IS PROPRIETARY TO MOLEX INCORPORATED AND SHOULD NOT BE USED WITHOUT WRITTEN PERMISSION

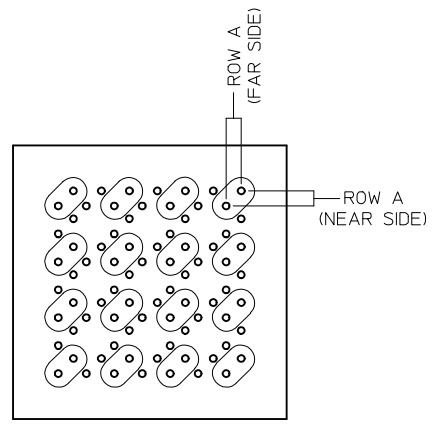

ORTHOGONAL MIDPLANE HOLE PATTERN  
(16 SIGNAL PAIRS SHARE VIAS)

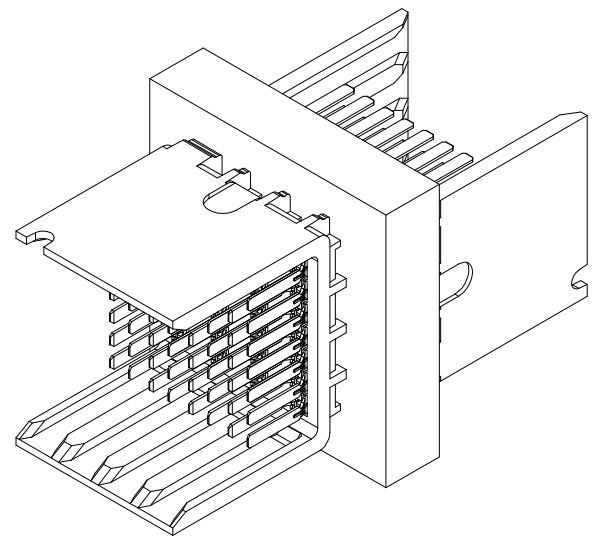

16 PAIR ORTHOGONAL MIDPLANE NODE  
(USES TWO 4 COLUMN 7 ROW HEADERS)

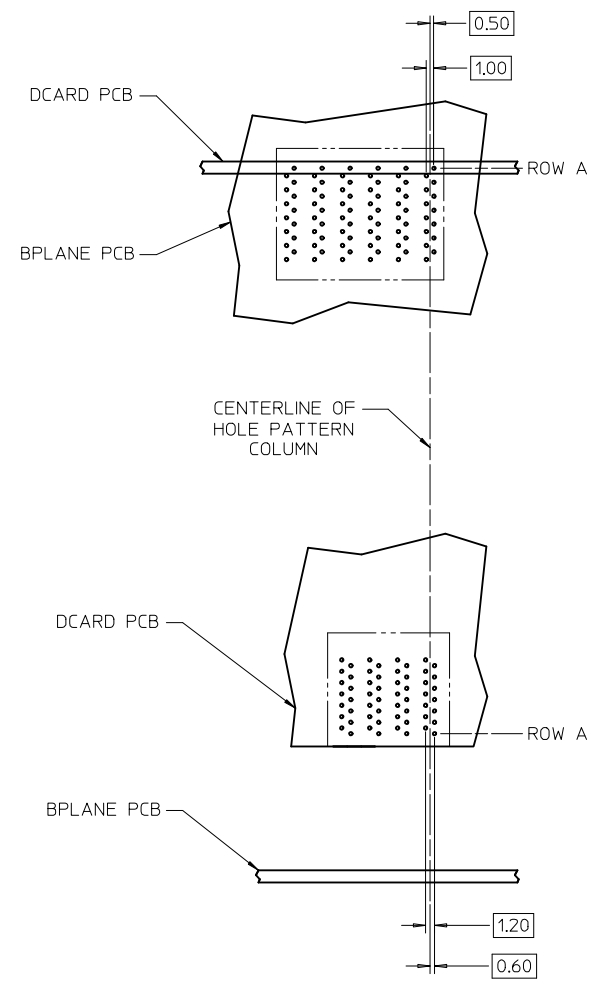

7 ROW I-TRAC  
BOARD RELATIONSHIPS

SCALE 2:1

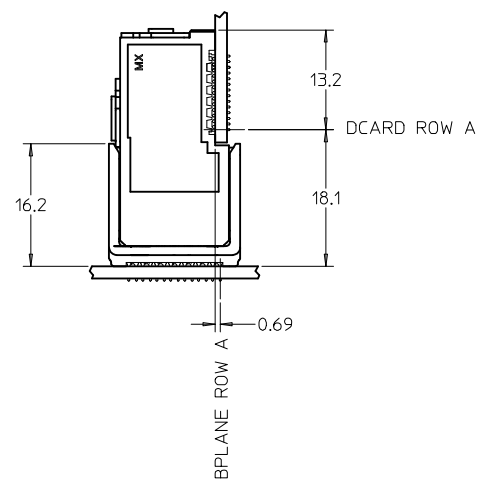

<b>REV ORTHO HOLE PATTERN</b> EC NO: UCP2009-2507 DRAWN: STEWART 2009/04/16 CHKD: BINGHAM 2009/04/17 APPR: BINGHAM 2009/04/17	QUALITY SYMBOLS ▽=0 ▽=0	GENERAL TOLERANCES (UNLESS SPECIFIED) mm INCH 4 PLACES ± --- ± --- 3 PLACES ± --- ± --- 2 PLACES ± 0.13 ± --- 1 PLACE ± 0.25 ± --- ANGULAR ± 1/2°	DIMENSION STYLE <b>MM ONLY</b> DRAWN BY DATE BPISZCZOR 2007/01/25 CHECKED BY DATE JLAURX 2007/02/06 APPROVED BY DATE CBIXLER 2007/02/06	SCALE <b>4:1</b> DESIGN UNITS METRIC THIRD ANGLE PROJECTION	TITLE <b>I-TRAC BACKPLANE 7 ROW                  UNGUIDED ASSEMBLY                  SALES DRAWING</b>	MATERIAL NO. <b>SEE CHART</b>	DOCUMENT NO. <b>SD-76015-001</b>	SHEET NO. <b>3 OF 4</b>
	DRAFT WHERE APPLICABLE MUST REMAIN WITHIN DIMENSIONS		THIS DRAWING CONTAINS INFORMATION THAT IS PROPRIETARY TO MOLEX INCORPORATED AND SHOULD NOT BE USED WITHOUT WRITTEN PERMISSION		MOLEX MOLEX INCORPORATED			
	REV D		SIZE C					

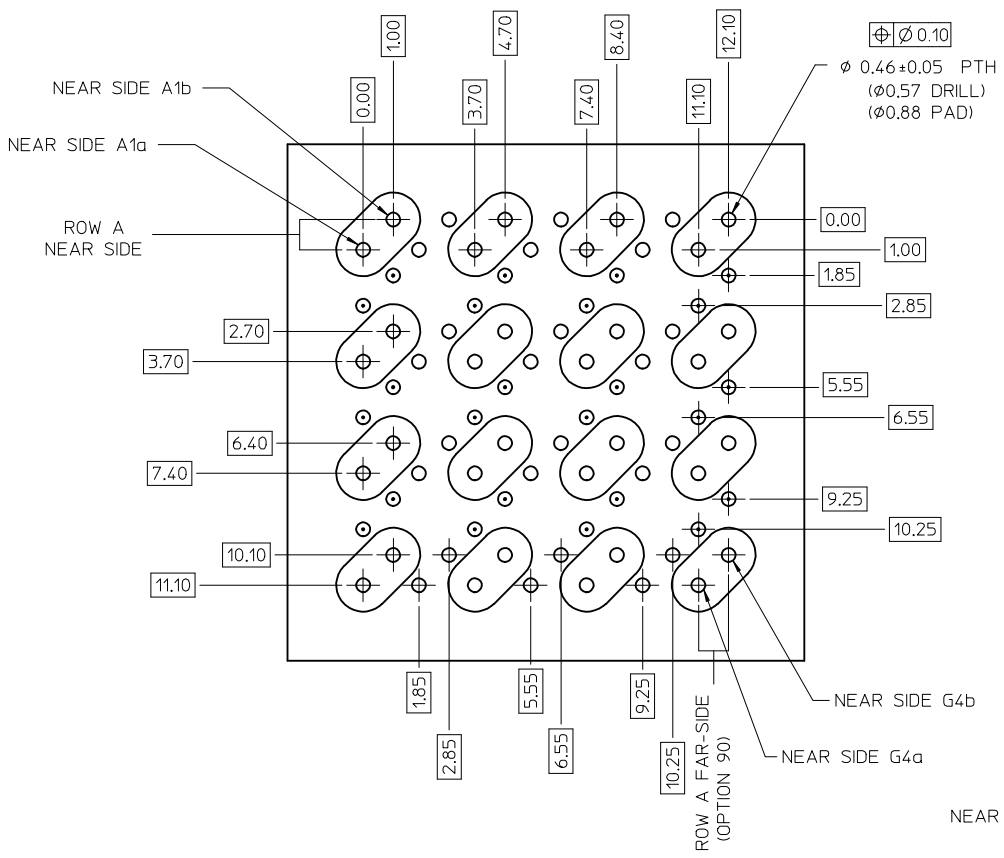

Orthogonal PCB Layout

ORTHO PIN MAPPING			
OPTION 90 (NEAR SIDE - FAR SIDE)			
A1b-G4b	A2b-E4b	A3b-C4b	A4b-A4b
A1a-G4a	A2a-E4a	A3a-C4a	A4a-A4a
C1b-G3b	C2b-E3b	C3b-C3b	C4b-A3b
C1a-G3a	C2a-E3a	C3a-C3a	C4a-A3a
E1b-G2b	E2b-E2b	E3b-C2b	E4b-A2b
E1a-G2a	E2a-E2a	E3a-C2a	E4a-A2a
G1b-G1b	G2b-E1b	G3b-C1b	G4b-A1b
G1a-G1a	G2a-E1a	G3a-C1a	G4a-A1a

ORTHO PIN MAPPING			
OPTION 270 (NEAR SIDE - FAR SIDE)			
A1b-A1a	A2b-C1a	A3b-E1a	A4b-G1a
A1a-A1b	A2a-C1b	A3a-E1b	A4a-G1b
C1b-A2a	C2b-C2a	C3b-E2a	C4b-G2a
C1a-A2b	C2a-C2b	C3a-E2b	C4a-G2b
E1b-A3a	E2b-C3a	E3b-E3a	E4b-G3a
E1a-A3b	E2a-C3b	E3a-E3b	E4a-G3b
G1b-A4a	G2b-C4a	G3b-E4a	G4b-G4a
G1a-A4b	G2a-C4b	G3a-E4b	G4a-G4b

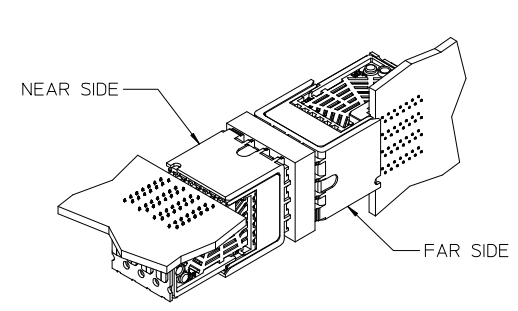

OPTION 90

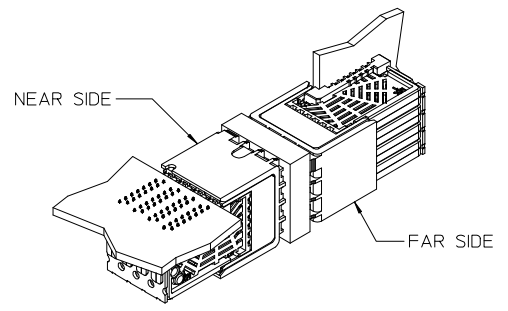

OPTION 270

NOTES:

- SIGNAL PAIRS (SHARED VIAS)
- NEAR SIDE GROUNDS
- FAR SIDE GROUNDS

<b>REV ORTHO PCB LAYOUT</b> EC NO: UCP2009-2507 DRAWN: C STEWART 2009/04/16 CHKD: J BINGHAM 2009/04/17 APPR: J BINGHAM 2009/04/17	QUALITY SYMBOLS ▽=0 ▽=0	GENERAL TOLERANCES (UNLESS SPECIFIED)		DIMENSION STYLE <b>MM ONLY</b>	SCALE <b>4:1</b>	DESIGN UNITS <b>METRIC</b>	THIRD ANGLE PROJECTION		
		4 PLACES ± --- ± --- 3 PLACES ± --- ± --- 2 PLACES ± 0.13 ± --- 1 PLACE ± 0.25 ± ---	mm INCH	DRAWN BY BPISZCZOR	DATE 2007/01/25	TITLE <b>I-TRAC BACKPLANE 7 ROW UNGUIDED ASSEMBLY SALES DRAWING</b>			
		ANGULAR ± 1/2°		CHECKED BY JLAURX	DATE 2007/02/06	MATERIAL NO. <b>SEE CHART</b>			
		DRAFT WHERE APPLICABLE MUST REMAIN WITHIN DIMENSIONS		APPROVED BY CBIXLER	DATE 2007/02/06	DOCUMENT NO. <b>SD-76015-001</b>		SHEET NO. <b>4 OF 4</b>	