

# TPS3852-Q1 High-Accuracy Voltage Supervisor with Integrated Watchdog Timer

## 1 Features

- AEC-Q100 Qualified with the Following Results:
  - Device Temperature Grade 1:  $-40^{\circ}\text{C}$  to  $125^{\circ}\text{C}$  Ambient Operating Temperature Range
  - Device HBM ESD Classification Level 2
  - Device CDM ESD Classification Level C4B
- $V_{\text{DD}}$  Input Voltage Range: 1.6 V to 6.5 V
- 0.8% Voltage Threshold Accuracy
- Low Supply Current:  $I_{\text{DD}} = 10 \mu\text{A}$  (typ)
- User-Programmable Watchdog Timeout
- Factory-Programmed Precision Watchdog and Reset Timers:
  - $\pm 15\%$  Accurate WDT and RST Delays
- Open-Drain Outputs
- Manual Reset Input ( $\overline{\text{MR}}$ )
- Precision Voltage Monitoring:
  - Supports Common Rails from 1.8 V to 5.0 V
  - 4% and 7% Thresholds Available
  - 0.5% Hysteresis
- Watchdog Disable Feature
- Available in a Small 3-mm  $\times$  3-mm, 8-Pin VSON Package

## 2 Applications

- Safety-Critical Applications
- Automotive Vision Systems
- Automotive ADAS Systems
- Telematics Control Units
- FPGAs and ASICs
- Microcontrollers and DSPs

## 3 Description

The TPS3852-Q1 is a precision voltage supervisor with an integrated window watchdog timer. The TPS3852-Q1 includes a precision undervoltage supervisor with an undervoltage threshold ( $V_{\text{ITN}}$ ) that achieves 0.8% accuracy over the specified temperature range of  $-40^{\circ}\text{C}$  to  $+125^{\circ}\text{C}$ . In addition, the TPS3852-Q1 includes accurate hysteresis making the device ideal for use with tight tolerance systems. The supervisor  $\overline{\text{RESET}}$  delay features a 15% accuracy, high-precision delay timer.

The TPS3852-Q1 includes a programmable window watchdog timer for a wide variety of applications. The dedicated watchdog output (WDO) enables increased resolution to help determine the nature of fault conditions. The watchdog timeouts can be programmed either by an external capacitor or by factory-programmed default delay settings. The watchdog can be disabled to avoid undesired watchdog timeouts during the development process.

The TPS3852-Q1 is available in a small 3.00-mm  $\times$  3.00-mm, 8-pin VSON package. The TPS3852-Q1 features wettable flanks that allow for easy optical inspection.

### Device Information<sup>(1)</sup>

PART NUMBER	PACKAGE	BODY SIZE (NOM)
TPS3852-Q1	VSON (8)	3.00 mm $\times$ 3.00 mm

(1) For all available packages, see the orderable addendum at the end of the data sheet.

### Typical Application Circuit

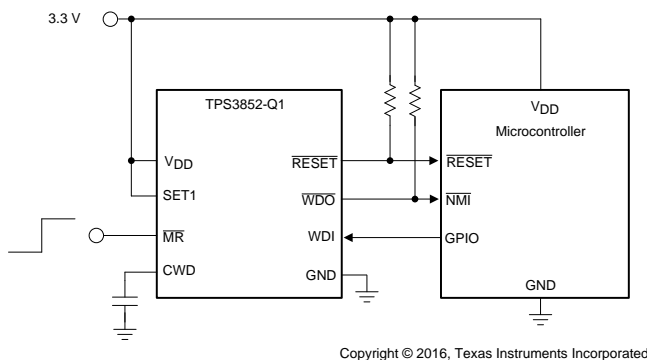

### Undervoltage Threshold ( $V_{\text{ITN}}$ ) Accuracy vs Temperature

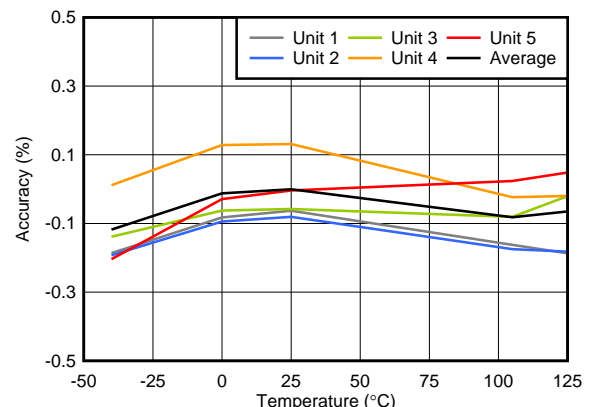

## Table of Contents

<b>1 Features</b> .....	<b>1</b>	7.4 Device Functional Modes.....	<b>15</b>
<b>2 Applications</b> .....	<b>1</b>	<b>8 Application and Implementation</b> .....	<b>16</b>
<b>3 Description</b> .....	<b>1</b>	8.1 Application Information.....	<b>16</b>
<b>4 Revision History</b> .....	<b>2</b>	8.2 Typical Application .....	<b>19</b>
<b>5 Pin Configuration and Functions</b> .....	<b>3</b>	<b>9 Power Supply Recommendations</b> .....	<b>22</b>
<b>6 Specifications</b> .....	<b>4</b>	<b>10 Layout</b> .....	<b>22</b>
6.1 Absolute Maximum Ratings .....	4	10.1 Layout Guidelines .....	22
6.2 ESD Ratings.....	4	10.2 Layout Example .....	22
6.3 Recommended Operating Conditions .....	4	<b>11 Device and Documentation Support</b> .....	<b>23</b>
6.4 Thermal Information .....	5	11.1 Device Support .....	23
6.5 Electrical Characteristics.....	5	11.2 Receiving Notification of Documentation Updates	23
6.6 Timing Requirements .....	6	11.3 Community Resources.....	23
6.7 Typical Characteristics .....	8	11.4 Trademarks .....	23
<b>7 Detailed Description</b> .....	<b>11</b>	11.5 Electrostatic Discharge Caution.....	23
7.1 Overview .....	11	11.6 Glossary .....	23
7.2 Functional Block Diagram .....	11	<b>12 Mechanical, Packaging, and Orderable</b>	
7.3 Feature Description.....	12	<b>Information</b> .....	<b>24</b>

## 4 Revision History

DATE	REVISION	NOTES
February 2017	*	Initial release.

## 5 Pin Configuration and Functions

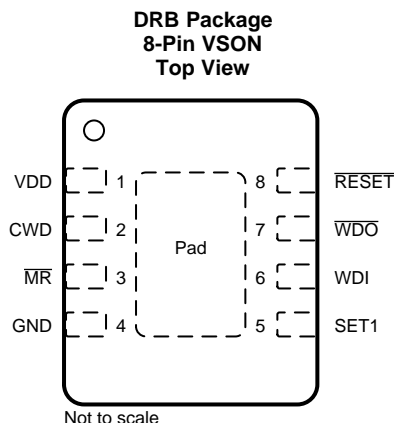

### Pin Functions

NAME	NO.	I/O	DESCRIPTION
CWD	2	—	Programmable watchdog timeout input. Watchdog timeout is set by connecting a capacitor between this pin and ground. Furthermore, this pin can also be connected by a 10-k $\Omega$ resistor to VDD, or leaving unconnected (NC) further enables the selection of the preset watchdog timeouts; see the <a href="#">Timing Requirements</a> table. When using a capacitor, the TPS3852-Q1 determines the window watchdog upper boundary with <a href="#">Equation 1</a> . See <a href="#">Table 4</a> and the <a href="#">CWD Functionality</a> section for additional information.
GND	4	—	Ground pin
$\overline{\text{MR}}$	3	I	Manual reset pin. A logical low on this pin issues a $\overline{\text{RESET}}$ . This pin is internally pulled up to VDD. $\overline{\text{RESET}}$ remains low for a fixed reset delay ( $t_{\text{RST}}$ ) time after $\overline{\text{MR}}$ is deasserted (high).
$\overline{\text{RESET}}$	8	O	Reset output. Connect $\overline{\text{RESET}}$ using a 1-k $\Omega$ to 100-k $\Omega$ resistor to the desired pullup voltage rail ( $V_{\text{PU}}$ ). $\overline{\text{RESET}}$ goes low when VDD goes below the undervoltage threshold ( $V_{\text{ITN}}$ ). When VDD is within the normal operating range, the $\overline{\text{RESET}}$ timeout counter starts. At completion, $\overline{\text{RESET}}$ goes high. During startup, the state of $\overline{\text{RESET}}$ is undefined below the specified power-on-reset (POR) voltage ( $V_{\text{POR}}$ ). Above POR, $\overline{\text{RESET}}$ goes low and remains low until the monitored voltage is within the correct operating range (above $V_{\text{ITN}} + V_{\text{HYST}}$ ) and the $\overline{\text{RESET}}$ timeout is complete.
SET1	5	I	Logic input. Grounding the SET1 pin disables the watchdog timer.
VDD	1	I	Supply voltage pin. For noisy systems, connecting a 0.1- $\mu\text{F}$ bypass capacitor is recommended.
WDI	6	I	Watchdog input. A falling transition (edge) must occur at this pin between the lower ( $t_{\text{WDL(max)}}$ ) and upper ( $t_{\text{WDL(min)}}$ ) window boundaries in order for WDO to not assert. When the watchdog is not in use, the SET1 pin can be used to disable the watchdog. The input at WDI is ignored when $\overline{\text{RESET}}$ or $\overline{\text{WDO}}$ are low (asserted) and also when the watchdog is disabled. If the watchdog is disabled, then WDI cannot be left unconnected and must be driven to either VDD or GND.
$\overline{\text{WDO}}$	7	O	Watchdog output. Connect $\overline{\text{WDO}}$ with a 1-k $\Omega$ to 100-k $\Omega$ resistor to the desired pullup voltage rail ( $V_{\text{PU}}$ ). $\overline{\text{WDO}}$ goes low (asserts) when a watchdog timeout occurs. $\overline{\text{WDO}}$ only asserts when $\overline{\text{RESET}}$ is high. When a watchdog timeout occurs, $\overline{\text{WDO}}$ goes low (asserts) for the set $\overline{\text{RESET}}$ timeout delay ( $t_{\text{RST}}$ ). When $\overline{\text{RESET}}$ goes low, WDO is in a high-impedance state.
Thermal pad		—	Connect the thermal pad to a large-area ground plane. The thermal pad is internally connected to GND.

## 6 Specifications

### 6.1 Absolute Maximum Ratings

over operating free-air temperature range (unless otherwise noted)<sup>(1)</sup>

		MIN	MAX	UNIT
Supply voltage range	VDD	-0.3	7	V
Output voltage range	$\overline{\text{RESET}}$ , $\overline{\text{WDO}}$	-0.3	7	V
Voltage ranges	SET1, WDI, $\overline{\text{MR}}$	-0.3	7	V
	CWD, CRST	-0.3	$V_{\text{DD}} + 0.3$ <sup>(2)</sup>	
Output pin current			±20	mA
Input current (all pins)			±20	mA
Continuous total power dissipation		See <a href="#">Thermal Information</a>		
Temperature	Operating junction, $T_{\text{J}}$ <sup>(3)</sup>	-40	150	°C
	Operating free-air, $T_{\text{A}}$ <sup>(3)</sup>	-40	150	
	Storage, $T_{\text{stg}}$	-65	150	

- (1) Stresses beyond those listed under *Absolute Maximum Ratings* may cause permanent damage to the device. These are stress ratings only, which do not imply functional operation of the device at these or any other conditions beyond those indicated under *Recommended Operating Conditions*. Exposure to absolute-maximum-rated conditions for extended periods may affect device reliability.
- (2) The absolute maximum rating is  $V_{\text{DD}} + 0.3$  V or 7.0 V, whichever is smaller.
- (3) Assume that  $T_{\text{J}} = T_{\text{A}}$  as a result of the low dissipated power in this device.

### 6.2 ESD Ratings

		VALUE	UNIT
$V_{\text{(ESD)}}$ Electrostatic discharge	Human-body model (HBM), per AEC Q100-002 <sup>(1)</sup>	±2000	V
	Charged-device model (CDM), per AEC Q100-011	±750	

- (1) AEC Q100-002 indicates that HBM stressing shall be in accordance with the ANSI/ESDA/JEDEC JS-001 specification.

### 6.3 Recommended Operating Conditions

over operating free-air temperature range (unless otherwise noted)

		MIN	NOM	MAX	UNIT
$V_{\text{DD}}$	Supply pin voltage	1.6		6.5	V
$V_{\text{SET1}}$	SET1 pin voltage	0		6.5	V
$V_{\overline{\text{MR}}}$	MR pin voltage	0		6.5	V
$C_{\text{CWD}}$	Watchdog timing capacitor	0.1 <sup>(1)</sup>		1000 <sup>(1)</sup>	nF
CWD	Pullup resistor to VDD	9	10	11	kΩ
$R_{\text{PU}}$	Pullup resistor, $\overline{\text{RESET}}$ and $\overline{\text{WDO}}$	1	10	100	kΩ
$I_{\overline{\text{RESET}}}$	$\overline{\text{RESET}}$ pin current			10	mA
$I_{\overline{\text{WDO}}}$	Watchdog output current			10	mA
$T_{\text{J}}$	Junction temperature	-40		125	°C

- (1) Using a  $C_{\text{CWD}}$  capacitor of 0.1 nF or 1000 nF gives a  $t_{\text{WDO(typ)}}$  of 62.74 ms or 77.45 seconds, respectively.

## 6.4 Thermal Information

THERMAL METRIC <sup>(1)</sup>		TPS3852-Q1	UNIT
		DRB (VSON)	
		8 PINS	
R <sub>θJA</sub>	Junction-to-ambient thermal resistance	47.7	°C/W
R <sub>θJC(top)</sub>	Junction-to-case (top) thermal resistance	51.5	°C/W
R <sub>θJB</sub>	Junction-to-board thermal resistance	22.2	°C/W
ψ <sub>JT</sub>	Junction-to-top characterization parameter	1.3	°C/W
ψ <sub>JB</sub>	Junction-to-board characterization parameter	22.3	°C/W
R <sub>θJC(bot)</sub>	Junction-to-case (bottom) thermal resistance	4.3	°C/W

(1) For more information about traditional and new thermal metrics, see the [Semiconductor and IC Package Thermal Metrics](#) application report.

## 6.5 Electrical Characteristics

at  $V_{ITN} + V_{HYST} \leq V_{DD} \leq 6.5 \text{ V}$  over the operating temperature range of  $-40^\circ\text{C} \leq T_A, T_J \leq +125^\circ\text{C}$  (unless otherwise noted); the open-drain pullup resistors are 10 kΩ for each output; typical values are at  $T_J = 25^\circ\text{C}$

PARAMETER	TEST CONDITIONS	MIN	TYP	MAX	UNIT			
<b>GENERAL CHARACTERISTICS</b>								
V <sub>DD</sub> <sup>(1)</sup>	Supply voltage	1.6		6.5	V			
I <sub>DD</sub>	Supply current		10	19	μA			
<b>RESET FUNCTION</b>								
V <sub>POR</sub> <sup>(2)</sup>	Power-on-reset voltage	I <sub>RESET</sub> = 15 μA, V <sub>OL(MAX)</sub> = 0.25 V			0.8	V		
V <sub>UVLO</sub> <sup>(3)</sup>	Undervoltage lockout voltage		1.35		V			
V <sub>ITN</sub>	Undervoltage threshold accuracy, entering RESET	V <sub>DD</sub> falling	V <sub>ITN</sub> - 0.8%	V <sub>ITN</sub> + 0.8%				
V <sub>HYST</sub>	Hysteresis voltage	V <sub>DD</sub> rising	0.2%	0.5%	0.8%			
I <sub>MR</sub>	MR pin internal pullup current	V <sub>MR</sub> = 0 V	500	620	700	nA		
<b>WINDOW WATCHDOG FUNCTION</b>								
I <sub>CWD</sub>	CWD pin charge current	CWD = 0.5 V			337	375	413	nA
V <sub>CWD</sub>	CWD pin threshold voltage		1.192	1.21	1.228	V		
V <sub>OL</sub>	RESET, WDO output low	V <sub>DD</sub> = 5 V, I <sub>RESET</sub> = I <sub>WDO</sub> = 3 mA			0.4	V		
I <sub>D</sub>	RESET, WDO output leakage current, open-drain	V <sub>DD</sub> = V <sub>ITN</sub> + V <sub>HYST</sub> , V <sub>RESET</sub> = V <sub>WDO</sub> = 6.5 V			1	μA		
V <sub>IL</sub>	Low-level input voltage (MR, SET1)			0.25	V			
V <sub>IH</sub>	High-level input voltage (MR, SET1)		0.8		V			
V <sub>IL(WDI)</sub>	Low-level input voltage (WDI)			0.3 × V <sub>DD</sub>	V			
V <sub>IH(WDI)</sub>	High-level input voltage (WDI)		0.8 × V <sub>DD</sub>		V			

(1) During power on, V<sub>DD</sub> must be a minimum of 1.6 V for at least 300 μs before RESET correlates with V<sub>DD</sub>.

(2) When V<sub>DD</sub> falls below V<sub>POR</sub>, RESET and WDO are undefined.

(3) When V<sub>DD</sub> falls below UVLO, RESET is driven low.

## 6.6 Timing Requirements

at  $V_{ITN} + V_{HYST} \leq V_{DD} \leq 6.5\text{ V}$  over the operating temperature range of  $-40^{\circ}\text{C} \leq T_A, T_J \leq +125^{\circ}\text{C}$  (unless otherwise noted); the open-drain pullup resistors are 10 k $\Omega$  for each output; typical values are at  $T_J = 25^{\circ}\text{C}$

		MIN	TYP	MAX	UNIT	
<b>GENERAL</b>						
$t_{INIT}$	CWD pin evaluation period		381		$\mu\text{s}$	
	Minimum $\overline{\text{MR}}$ , SET1 pin pulse duration		1		$\mu\text{s}$	
	Startup delay		300		$\mu\text{s}$	
<b>RESET FUNCTION</b>						
$t_{RST}$	Reset timeout period	170	200	230	ms	
$t_{RST-DEL}$	$V_{DD}$ to $\overline{\text{RESET}}$ delay	$V_{DD} = V_{ITN} + V_{HYST} + 2.5\%$	35		$\mu\text{s}$	
		$V_{DD} = V_{ITN} - 2.5\%$	17			
$t_{MR-DEL}$	$\overline{\text{MR}}$ to $\overline{\text{RESET}}$ delay		200		ns	
<b>Watchdog Function</b>						
$t_{WDL}$	Window watchdog lower boundary	CWD = NC, SET1 = 0 <sup>(1)</sup>	Watchdog disabled			
		CWD = NC, SET1 = 1 <sup>(1)</sup>	680	800	920	ms
		CWD = 10 k $\Omega$ to VDD, SET1 = 0 <sup>(1)</sup>	Watchdog disabled			
		CWD = 10 k $\Omega$ to VDD, SET1 = 1 <sup>(1)</sup>	1.48	1.85	2.22	ms
$t_{WDU}$	Window watchdog upper boundary	CWD = NC, SET1 = 0 <sup>(1)</sup>	Watchdog disabled			
		CWD = NC, SET1 = 1 <sup>(1)</sup>	1360	1600	1840	ms
		CWD = 10 k $\Omega$ to VDD, SET1 = 0 <sup>(1)</sup>	Watchdog disabled			
		CWD = 10 k $\Omega$ to VDD, SET1 = 1 <sup>(1)</sup>	9.35	11.0	12.65	ms
$t_{WD-setup}$	Setup time required for device to respond to changes on WDI after being enabled		150		$\mu\text{s}$	
	Minimum WDI pulse duration		50		ns	
$t_{WD-DEL}$	WDI to $\overline{\text{WDO}}$ delay		50		ns	

(1) SET1 = 0 means  $V_{SET1} < V_{IL}$ , SET1 = 1 means  $V_{SET1} > V_{IH}$ .

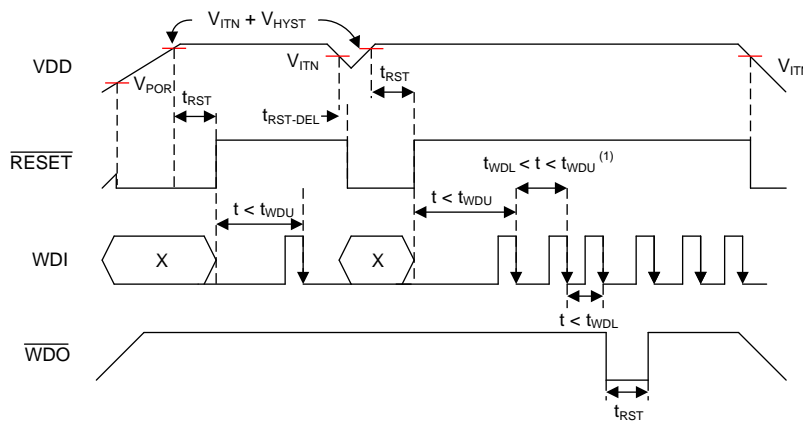

(1) See Figure 2 for WDI timing requirements.

Figure 1. Timing Diagram

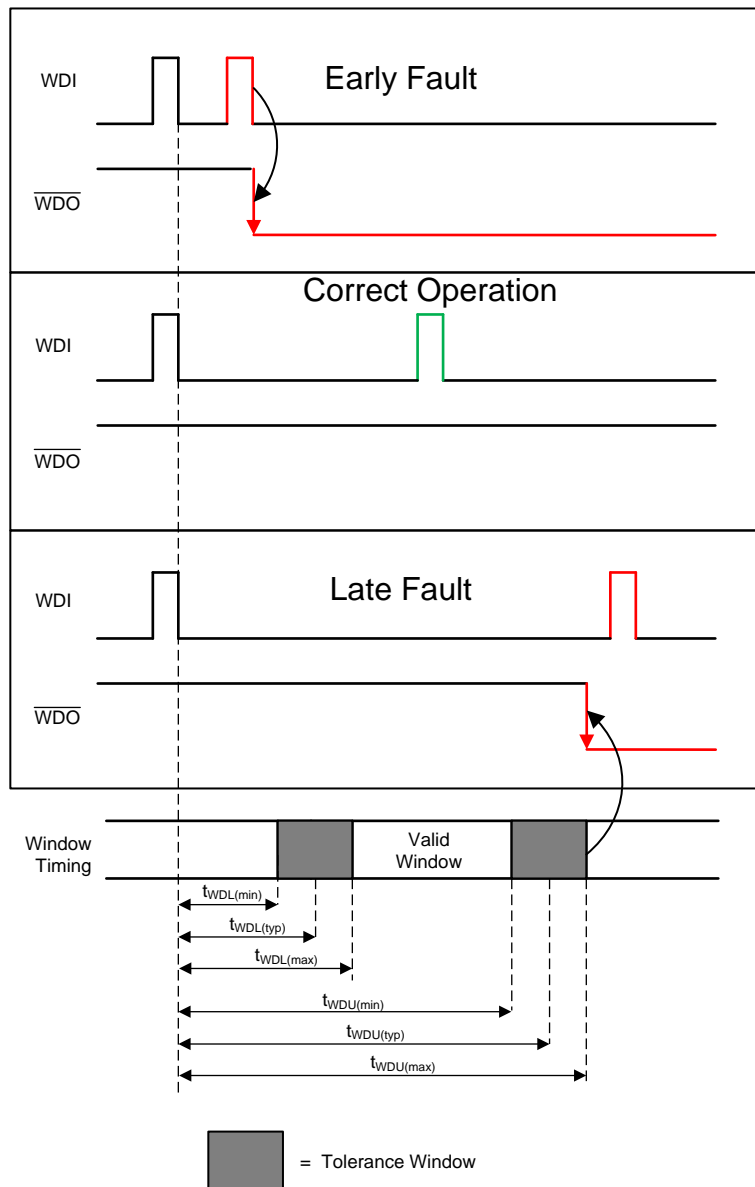

Figure 2. TPS3852-Q1 Window Watchdog Timing

### 6.7 Typical Characteristics

all curves are taken at 25°C with  $1.6\text{ V} \leq V_{DD} \leq 6.5\text{ V}$  (unless otherwise noted)

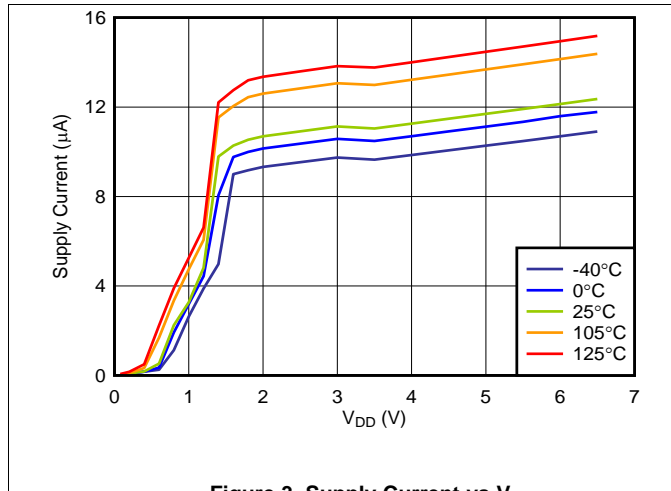

Figure 3. Supply Current vs  $V_{DD}$

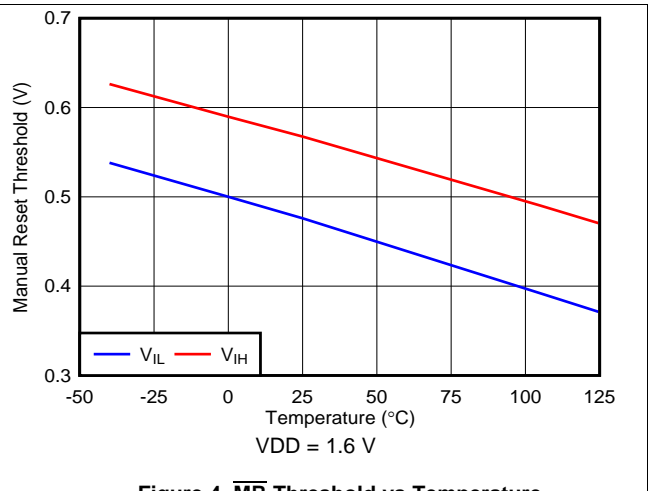

Figure 4.  $\overline{MR}$  Threshold vs Temperature

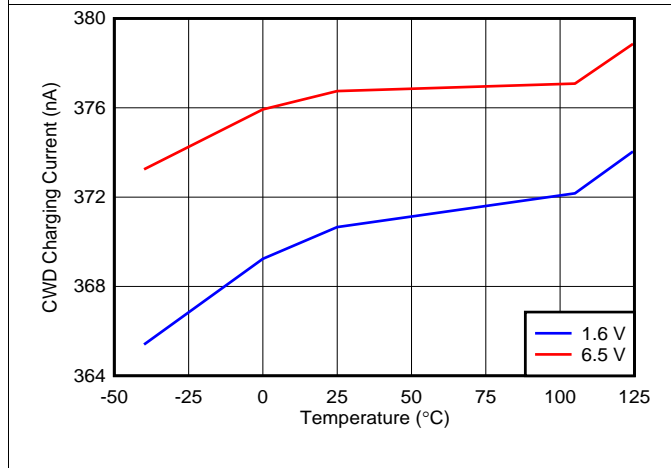

Figure 5. CWD Charging Current vs Temperature

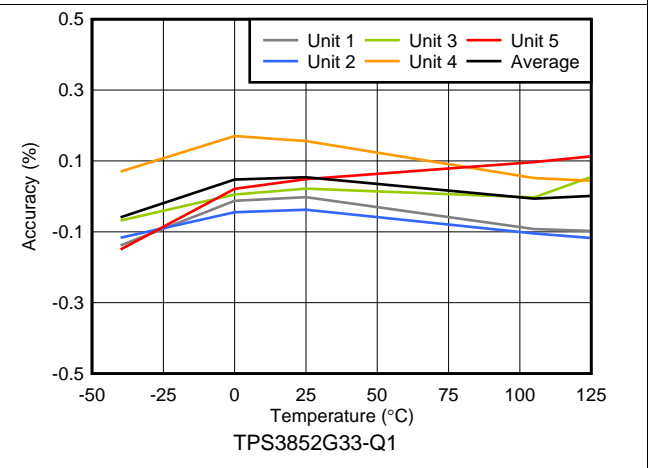

Figure 6.  $V_{ITN} + V_{HYS}$  Accuracy vs Temperature

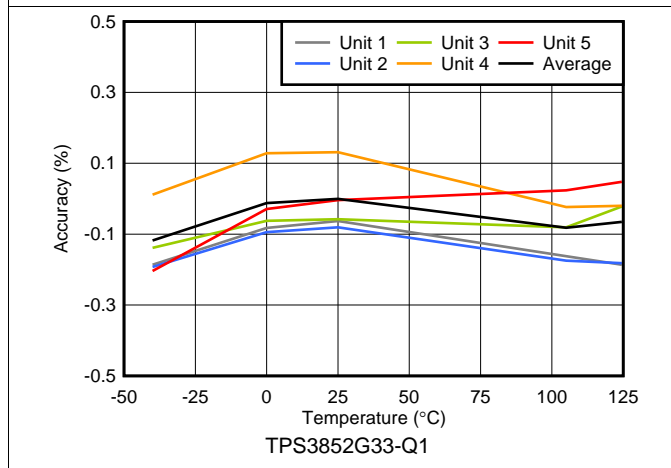
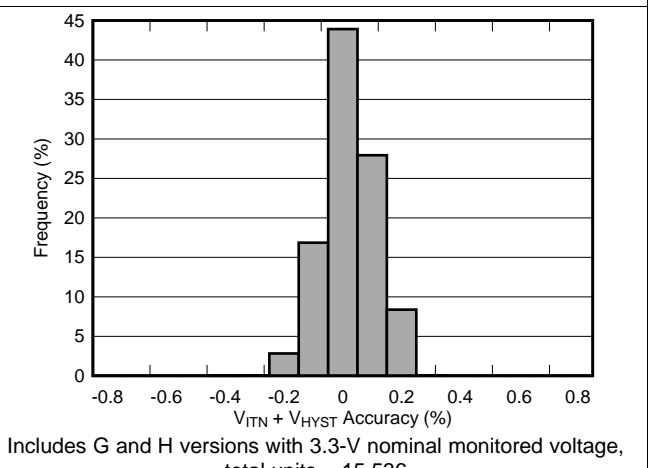

Figure 7.  $V_{ITN}$  Accuracy vs Temperature



Includes G and H versions with 3.3-V nominal monitored voltage, total units = 15,536

Figure 8.  $V_{ITN} + V_{HYS}$  Accuracy Histogram

### Typical Characteristics (continued)

all curves are taken at 25°C with 1.6 V ≤ VDD ≤ 6.5 V (unless otherwise noted)

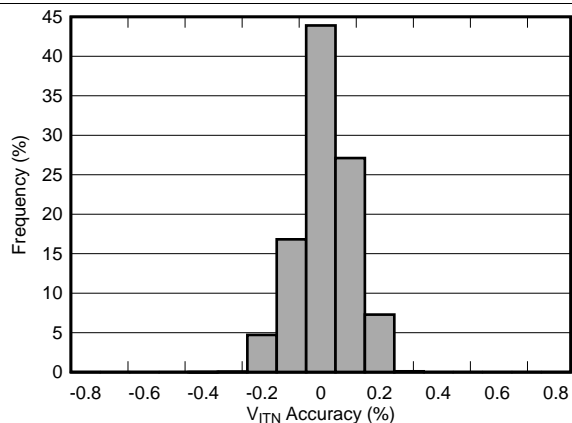

Includes G and H versions with 3.3-V nominal monitored voltage, total units = 15,536

Figure 9. V<sub>ITN</sub> Accuracy Histogram

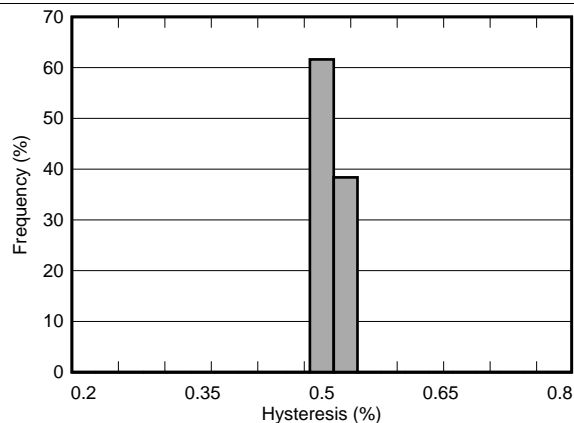

Includes G and H versions with 3.3-V nominal monitored voltage, total units = 15,536

Figure 10. Hysteresis Histogram

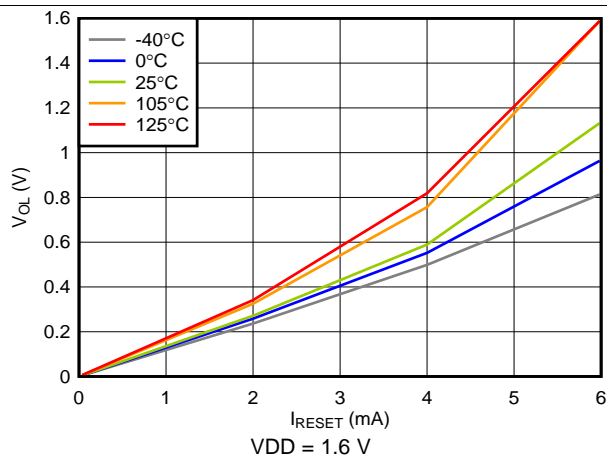

Figure 11. Low-Level  $\overline{\text{RESET}}$  Voltage vs  $\overline{\text{RESET}}$  Current

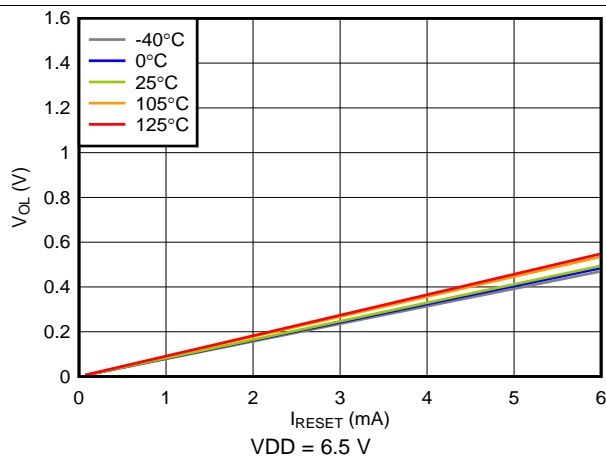
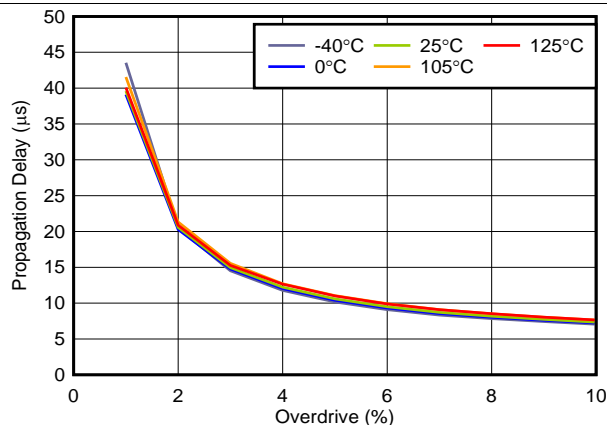
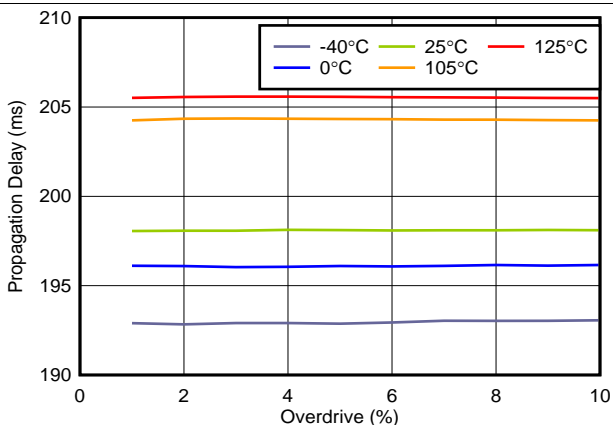

Figure 12. Low-Level  $\overline{\text{RESET}}$  Voltage vs  $\overline{\text{RESET}}$  Current



TPS3852G33-Q1 entering undervoltage

Figure 13. Propagation Delay vs Overdrive



TPS3852G33-Q1 exiting undervoltage

Figure 14. Propagation Delay ( $t_{\text{RST}}$ ) vs Overdrive

**Typical Characteristics (continued)**

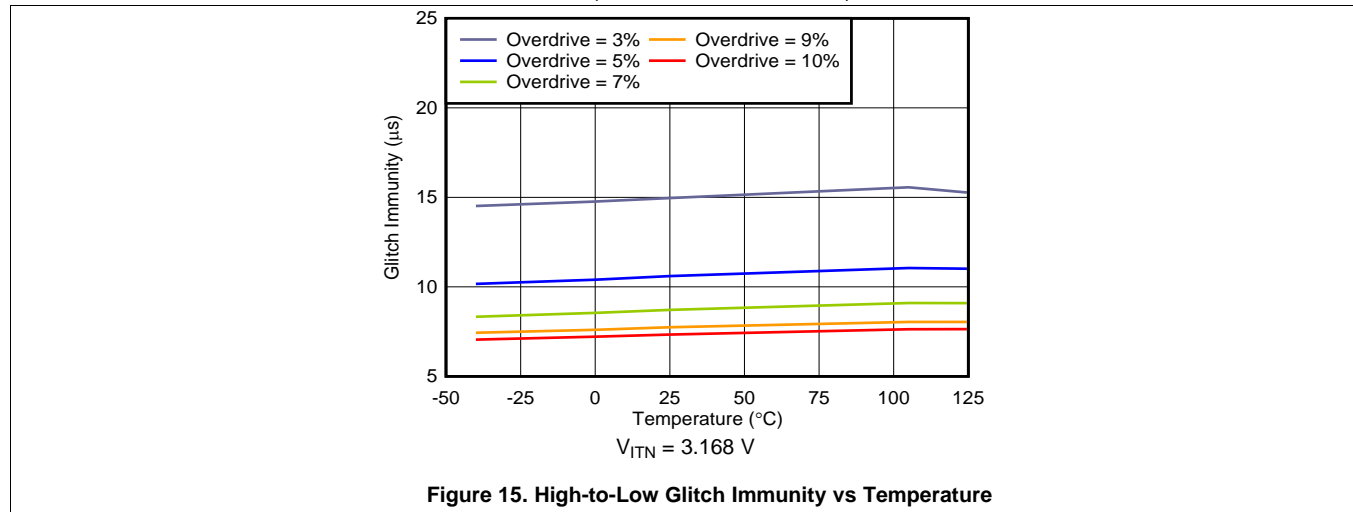
 all curves are taken at 25°C with  $1.6\text{ V} \leq V_{DD} \leq 6.5\text{ V}$  (unless otherwise noted)

## 7 Detailed Description

### 7.1 Overview

The TPS3852-Q1 is a high-accuracy voltage supervisor with an integrated window watchdog timer. This device includes a precision undervoltage supervisor with a threshold that achieves 0.8% accuracy over the specified temperature range of  $-40^{\circ}\text{C}$  to  $+125^{\circ}\text{C}$ . In addition, the TPS3852-Q1 includes accurate hysteresis on the threshold, making the device ideal for use with tight tolerance systems where voltage supervisors must ensure a RESET before the minimum supply tolerance of the microprocessor or system-on-a-chip (SoC) is reached.

### 7.2 Functional Block Diagram

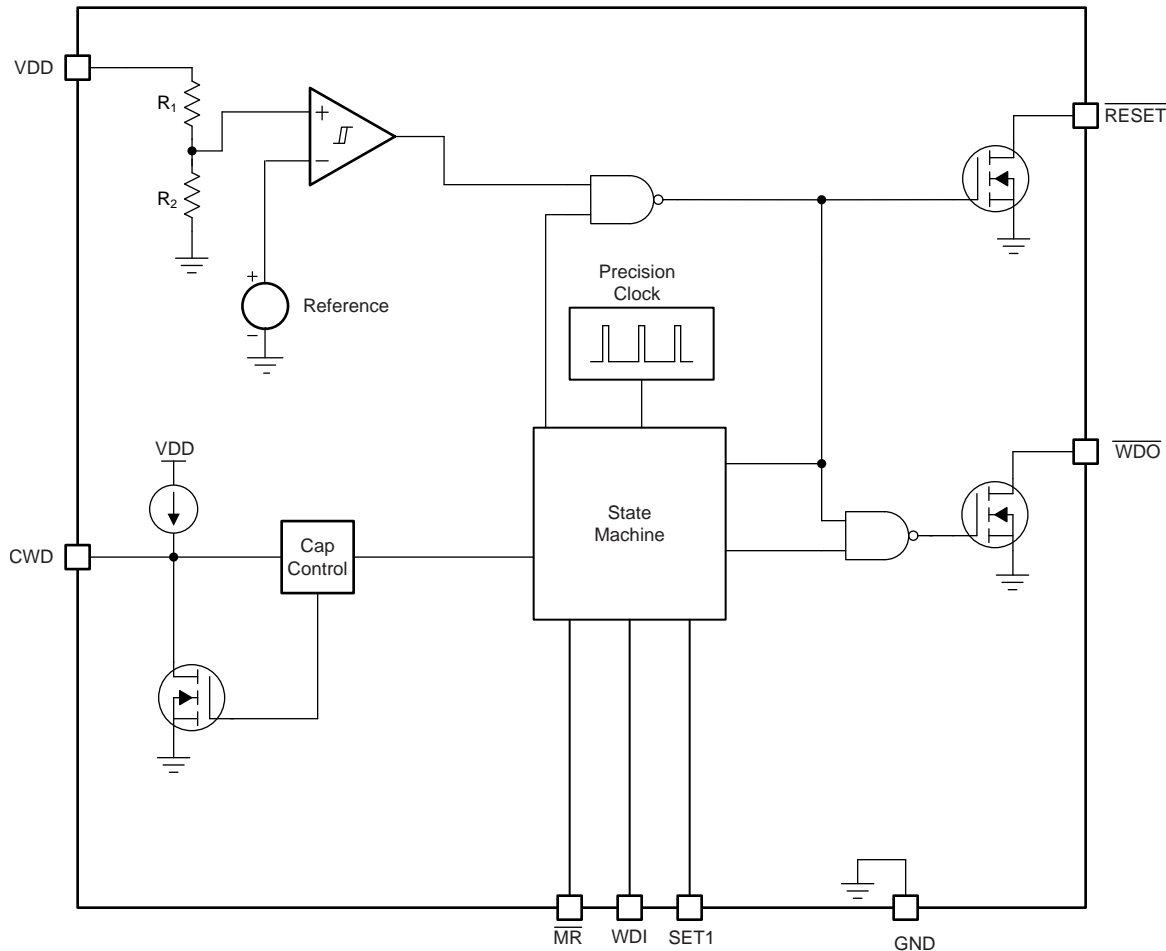

Copyright © 2016, Texas Instruments Incorporated

NOTE:  $R_1 + R_2 = 4.5 \text{ M}\Omega$ .

## 7.3 Feature Description

### 7.3.1 $\overline{\text{RESET}}$

Connect  $\overline{\text{RESET}}$  to  $V_{\text{PU}}$  through a 1-k $\Omega$  to 100-k $\Omega$  pullup resistor.  $\overline{\text{RESET}}$  remains high (deasserted) when  $V_{\text{DD}}$  is greater than the negative threshold voltage ( $V_{\text{ITN}}$ ). If  $V_{\text{DD}}$  falls below the negative threshold ( $V_{\text{ITN}}$ ), then  $\overline{\text{RESET}}$  is asserted, driving the  $\overline{\text{RESET}}$  pin to low impedance. When  $V_{\text{DD}}$  rises above  $V_{\text{ITN}} + V_{\text{HYST}}$ , a delay circuit is enabled that holds  $\overline{\text{RESET}}$  low for a specified reset delay period ( $t_{\text{RST}}$ ). When the reset delay has elapsed, the  $\overline{\text{RESET}}$  pin goes to a high-impedance state and uses a pullup resistor to hold  $\overline{\text{RESET}}$  high. The pullup resistor must be connected to the desired voltage rail to allow other devices to be connected at the correct interface voltage. To ensure proper voltage levels, give some consideration when choosing the pullup resistor values. The pullup resistor value is determined by output logic low voltage ( $V_{\text{OL}}$ ), leakage current ( $I_{\text{D}}$ ), and the current through the  $\overline{\text{RESET}}$  pin  $I_{\text{RESET}}$ .

### 7.3.2 Manual Reset ( $\overline{\text{MR}}$ )

The manual reset ( $\overline{\text{MR}}$ ) input allows a processor or other logic circuits to initiate a reset. A logic low on  $\overline{\text{MR}}$  causes  $\overline{\text{RESET}}$  to assert. After  $\overline{\text{MR}}$  returns to a logic high and  $V_{\text{DD}}$  is above  $V_{\text{ITN}} + V_{\text{HYST}}$ ,  $\overline{\text{RESET}}$  is deasserted after the reset delay time ( $t_{\text{RST}}$ ). If  $\overline{\text{MR}}$  is not controlled externally, then  $\overline{\text{MR}}$  can either be connected to  $V_{\text{DD}}$  or left floating because the  $\overline{\text{MR}}$  pin is internally pulled up. When  $\overline{\text{MR}}$  is asserted, the watchdog is disabled and all signals input to WDI are ignored.

### 7.3.3 Undervoltage Fault Detection

The TPS3852-Q1 features undervoltage detection for common rails between 1.8 V and 5 V. The voltage is monitored on the input rail of the device. If  $V_{\text{DD}}$  drops below  $V_{\text{ITN}}$ , then  $\overline{\text{RESET}}$  is asserted (driven low). When  $V_{\text{DD}}$  is above  $V_{\text{ITN}} + V_{\text{HYST}}$ ,  $\overline{\text{RESET}}$  deasserts after  $t_{\text{RST}}$ , as shown in Figure 16. The internal comparator has built-in hysteresis that provides some noise immunity and ensures stable operation. Although not required in most cases, for noisy applications, good analog design practice is to place a 1-nF to 100-nF bypass capacitor close to the VDD pin to reduce sensitivity to transient voltages on the monitored signal.

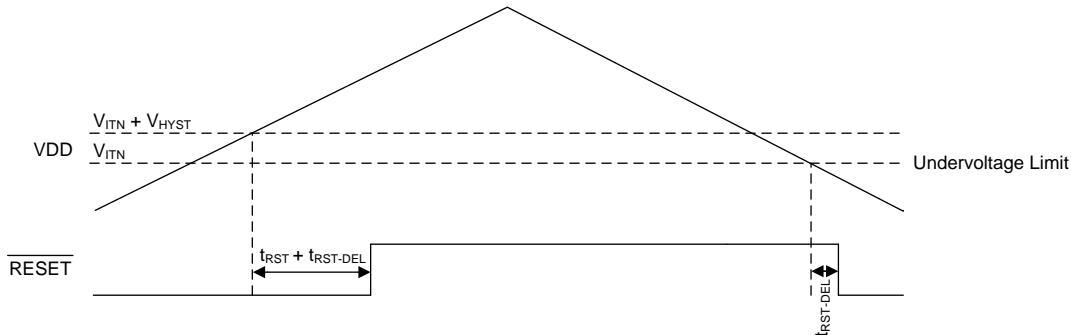

**Figure 16. Undervoltage Detection**

## Feature Description (continued)

### 7.3.4 Watchdog Mode

This section provides information for the watchdog mode of operation.

#### 7.3.4.1 SET1

The SET1 pin can enable and disable the watchdog timer. If SET1 is set to GND, the watchdog timer is disabled and WDI is ignored. When the watchdog is disabled,  $\overline{WDO}$  is in a high-impedance state. If the watchdog timer is disabled, drive the WDI pin to either GND or VDD to ensure that there is no increase in  $I_{DD}$ . When SET1 is logic high, the watchdog operates normally. The SET1 pin can be changed dynamically; however, if the watchdog is going from disabled to enabled there is a setup time  $t_{WD-setup}$  where the watchdog does not respond to changes on WDI, as shown in Figure 17.

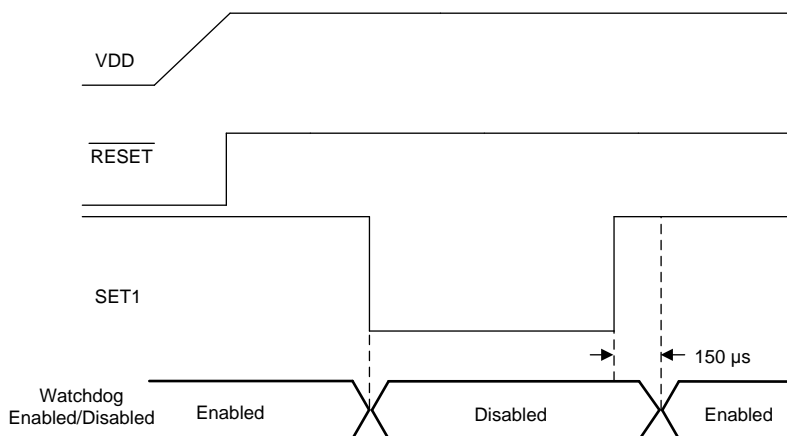

Figure 17. Enabling and Disabling the Watchdog

#### 7.3.4.2 Window Watchdog Timer

This section provides information for the window watchdog mode of operation. A window watchdog is typically employed in safety-critical applications where a traditional watchdog timer is inadequate. In a traditional watchdog there is a maximum time in which a pulse must be issued to prevent the reset from occurring. In a window watchdog, the pulse must be issued between a maximum lower window time ( $t_{WDL(max)}$ ) and the minimum upper window time ( $t_{WDU(min)}$ ) set by the CWD pin.

#### 7.3.4.3 Watchdog Input (WDI)

WDI is the watchdog timer input that controls the  $\overline{WDO}$  output. The WDI input is triggered by the falling edge of the input signal. For the first pulse, the watchdog acts as a traditional watchdog timer; thus, the first pulse must be issued before  $t_{WDU(min)}$ . After the first pulse, to ensure proper functionality of the watchdog timer, always issue the WDI pulse within the window of  $t_{WDL(max)}$  and  $t_{WDU(min)}$ . If the pulse is issued in this region, then  $\overline{WDO}$  remains unasserted. Otherwise the device asserts  $\overline{WDO}$ , putting the  $\overline{WDO}$  pin into a low-impedance state.

The watchdog input (WDI) is a digital pin. In order to ensure there is no increase in  $I_{DD}$ , drive the WDI pin to either VDD or GND at all times. Putting the pin to an intermediate voltage can cause an increase in supply current ( $I_{DD}$ ) because of the architecture of the digital logic gates. When  $\overline{RESET}$  is asserted, the watchdog is disabled and all signals input to WDI are ignored. When  $\overline{RESET}$  is no longer asserted, the device resumes normal operation and no longer ignores the signal on WDI. If the watchdog is disabled, drive the WDI pin to either VDD or GND.

## Feature Description (continued)

### 7.3.4.4 CWD

The CWD pin provides the functionality of both high-precision, factory-programmed window watchdog timing options and user-programmable window watchdog timing. The CWD pin can be either pulled up to  $V_{DD}$  through a resistor, have an external capacitor to ground, or be left floating. Every time that the device issues a reset event and the supply voltage is above  $V_{ITN}$ , the device tries to determine which of these three options is connected to the pin. There is an internal state machine that the device goes through to determine which option is connected to the CWD pin. The state machine can take up to 381  $\mu$ s to determine if the CWD pin is left floating, pulled-up through a resistor, or connected to a capacitor.

If the CWD pin is being pulled up to  $V_{DD}$  using a pullup resistor, then use a 10-k $\Omega$  resistor.

### 7.3.4.5 Watchdog Output ( $\overline{WDO}$ )

The TPS3852-Q1 features a window watchdog with an independent watchdog output ( $\overline{WDO}$ ). The independent watchdog output gives the flexibility to flag when there is a fault in the watchdog timing without performing an entire system reset. For legacy applications,  $\overline{WDO}$  can be tied to  $\overline{RESET}$ . When the  $\overline{RESET}$  output is not asserted, the  $\overline{WDO}$  signal maintains normal operation. However, when the  $\overline{RESET}$  signal is asserted, the  $\overline{WDO}$  pin goes to a high-impedance state. This is due to using the standard  $\overline{RESET}$  timing options when a fault occurs on  $\overline{WDO}$ . When  $\overline{RESET}$  is unasserted, the window watchdog timer resumes normal operation.

## 7.4 Device Functional Modes

Table 1 summarises the functional modes of the TPS3852-Q1.

**Table 1. Device Functional Modes**

$V_{DD}$	WDI	$\overline{WDO}$	$\overline{RESET}$
$V_{DD} < V_{POR}$	—	—	Undefined
$V_{POR} \leq V_{DD} < V_{DD(min)}$	Ignored	High	Low
$V_{DD(min)} \leq V_{DD} \leq V_{ITN} + V_{HYST}^{(1)}$	Ignored	High	Low
$V_{DD} > V_{ITN}^{(2)}$	$t_{WDL(max)} < t_{PULSE} < t_{WDU(min)}^{(3)}$	High	High
	$t_{PULSE} > t_{WDU(min)}^{(3)}$	Low	High
	$t_{PULSE} < t_{WDL(max)}^{(3)}$	Low	High

(1) Only valid before  $V_{DD}$  goes above  $V_{ITN} + V_{HYST}$ .

(2) Only valid after  $V_{DD}$  goes above  $V_{ITN} + V_{HYST}$ .

(3) Where  $t_{PULSE}$  is the time between the falling edges on WDI.

### 7.4.1 $V_{DD}$ is Below $V_{POR}$ ( $V_{DD} < V_{POR}$ )

When  $V_{DD}$  is less than  $V_{POR}$ ,  $\overline{RESET}$  is undefined and can be either high or low. The state of  $\overline{RESET}$  largely depends on the load that the  $\overline{RESET}$  pin is experiencing.

### 7.4.2 Above Power-On-Reset, But Less Than $V_{DD(min)}$ ( $V_{POR} \leq V_{DD} < V_{DD(min)}$ )

When the voltage on  $V_{DD}$  is less than  $V_{DD(min)}$  and greater than or equal to  $V_{POR}$ , the  $\overline{RESET}$  signal is asserted (logic low). When  $\overline{RESET}$  is asserted, the watchdog output  $\overline{WDO}$  is in a high-impedance state regardless of the WDI signal that is input to the device.

### 7.4.3 Normal Operation ( $V_{DD} \geq V_{DD(min)}$ )

When  $V_{DD}$  is greater than or equal to  $V_{DD(min)}$ , the  $\overline{RESET}$  signal is determined by  $V_{DD}$ . When  $\overline{RESET}$  is asserted,  $\overline{WDO}$  goes to a high-impedance state.  $\overline{WDO}$  is then pulled high through the pullup resistor.

## 8 Application and Implementation

### NOTE

Information in the following applications sections is not part of the TI component specification, and TI does not warrant its accuracy or completeness. TI's customers are responsible for determining suitability of components for their purposes. Customers should validate and test their design implementation to confirm system functionality.

### 8.1 Application Information

#### 8.1.1 CWD Functionality

The TPS3852-Q1 features three options for setting the watchdog window: connecting a capacitor to the CWD pin, connecting a pullup resistor to VDD, and leaving the CWD pin unconnected. Figure 18 shows a schematic drawing of all three options. If this pin is connected to VDD through a 10-k $\Omega$  pullup resistor or left unconnected (high impedance), then the factory-programmed watchdog timeouts are enabled; see the [Timing Requirements](#) table. Otherwise, the watchdog timeout can be adjusted by placing a capacitor from the CWD pin to ground.

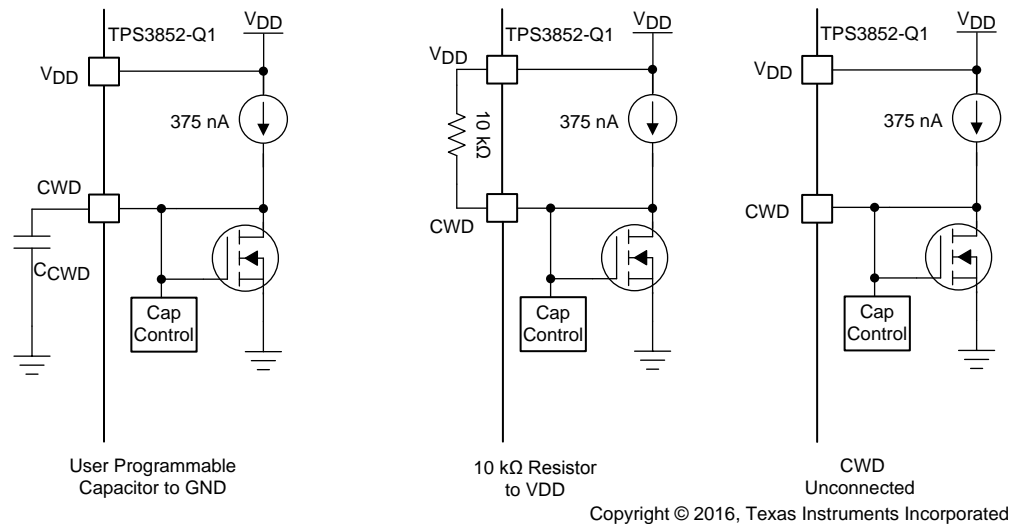

**Figure 18. CWD Charging Circuit**

##### 8.1.1.1 Factory-Programmed Timing Options

If using the factory-programmed timing options (listed in [Table 2](#)), the CWD pin must either be unconnected or pulled up to VDD through a 10-k $\Omega$  pullup resistor. Using these options enables high-precision watchdog timing.

**Table 2. Factory-Programmed Watchdog Timing**

INPUT		WATCHDOG LOWER BOUNDARY ( $t_{WDL}$ )			WATCHDOG UPPER BOUNDARY ( $t_{WDU}$ )			UNIT
CWD	SET1	MIN	TYP	MAX	MIN	TYP	MAX	
NC	0	Watchdog disabled			Watchdog disabled			
	1	680	800	920	1360	1600	1840	ms
10 k $\Omega$ to VDD	0	Watchdog disabled			Watchdog disabled			
	1	1.48	1.85	2.22	9.35	11.0	12.65	ms

### 8.1.1.2 Adjustable Capacitor Timing

Adjustable capacitor timing is achievable by connecting a capacitor to the CWD pin. If a capacitor is connected to CWD, then a 375-nA current source charges  $C_{CWD}$  until  $V_{CWD} = 1.21$  V. The TPS3852-Q1 determines the window watchdog upper boundary with the formula given in Equation 1, where  $C_{CWD}$  is in microfarads ( $\mu$ F) and  $t_{WDU}$  is in seconds.

$$t_{WDU(typ)}(s) = 77.4 \times C_{CWD}(\mu F) + 0.055 (s) \quad (1)$$

The TPS3852-Q1 is limited to using  $C_{CWD}$  capacitors between 100 pF and 1  $\mu$ F. Note that Equation 1 is for ideal capacitors; capacitor tolerances cause the actual device timing to vary. For the most accurate timing, use ceramic capacitors with COG dielectric material. As shown in Table 3, when using the minimum capacitance of 100 pF, the watchdog upper boundary is 62.74 ms; whereas with a 1- $\mu$ F capacitance, the watchdog upper boundary is 77.455 seconds. If a  $C_{CWD}$  capacitor is used, Equation 1 can be used to set the window watchdog upper boundary ( $t_{WDU}$ ). Table 4 shows how  $t_{WDU}$  can be used to calculate  $t_{WDL}$ .

**Table 3.  $t_{WDU}$  Values for Common Ideal Capacitor Values**

$C_{CWD}$	WATCHDOG UPPER BOUNDARY ( $t_{WDU}$ )			UNIT
	MIN <sup>(1)</sup>	TYP	MAX <sup>(1)</sup>	
100 pF	53.32	62.74	72.15	ms
1 nF	112.5	132.4	152.2	ms
10 nF	704	829	953	ms
100 nF	6625	7795	8964	ms
1 $\mu$ F	65836	77455	89073	ms

(1) Minimum and maximum values are calculated using ideal capacitors.

**Table 4. Programmable CWD Timing**

INPUT		WATCHDOG LOWER BOUNDARY ( $t_{WDL}$ )			WATCHDOG UPPER BOUNDARY ( $t_{WDU}$ )			UNIT
CWD	SET1	MIN	TYP	MAX	MIN	TYP	MAX	
$C_{CWD}$	0	Watchdog disabled			Watchdog disabled			s
	1	$t_{WDU(min)} \times 0.5$	$t_{WDU} \times 0.5$	$t_{WDU(max)} \times 0.5$	$0.85 \times t_{WDU(typ)}$	$t_{WDU(typ)}^{(1)}$	$1.15 \times t_{WDU(typ)}$	

(1) Calculated from Equation 1 using ideal capacitors.

### 8.1.2 Overdrive Voltage

Forcing a  $\overline{\text{RESET}}$  is dependent on two conditions: the amplitude  $V_{\text{DD}}$  is beyond the trip point ( $\Delta V_1$  and  $\Delta V_2$ ), and the length of time that the voltage is beyond the trip point for a long period of time,  $\overline{\text{RESET}}$  asserts and the output is pulled low. However, if  $V_{\text{DD}}$  is just under the trip point for a few nanoseconds,  $\overline{\text{RESET}}$  does not assert and the output remains high. The length of time required for  $\overline{\text{RESET}}$  to assert can be changed by increasing the amount  $V_{\text{DD}}$  goes under the trip point. If  $V_{\text{DD}}$  is under the trip point by 10%, the amount of time required for the comparator to respond is much faster and causes  $\overline{\text{RESET}}$  to assert much quicker than when barely under the trip point voltage. Equation 2 shows how to calculate the percentage overdrive.

$$\text{Overdrive} = |(V_{\text{DD}} / V_{\text{ITX}} - 1) \times 100\%| \quad (2)$$

In Equation 2,  $V_{\text{ITX}}$  corresponds to the threshold trip point. If  $V_{\text{DD}}$  is exceeding the positive threshold,  $V_{\text{ITN}} + V_{\text{HYST}}$  is used.  $V_{\text{ITN}}$  is used when  $V_{\text{DD}}$  is falling below the negative threshold. In Figure 19,  $t_1$  and  $t_2$  correspond to the amount of time that  $V_{\text{DD}}$  is over the threshold; the propagation delay versus overdrive for  $V_{\text{ITN}}$  and  $V_{\text{ITN}} + V_{\text{HYST}}$  is illustrated in Figure 13 and Figure 14, respectively.

The TPS3852-Q1 is relatively immune to short positive and negative transients on VDD because of the overdrive voltage.

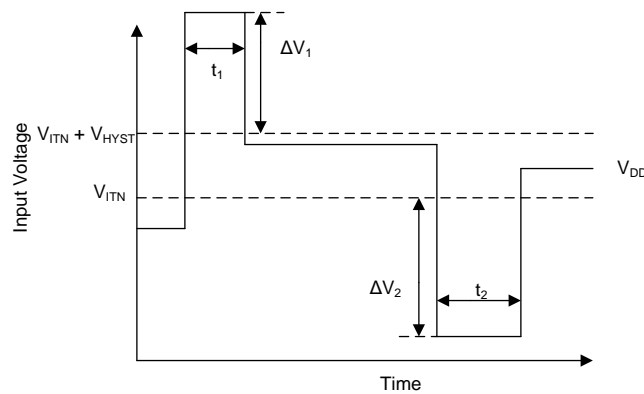

Copyright © 2016, Texas Instruments Incorporated

**Figure 19. Overdrive Voltage**

## 8.2 Typical Application

A typical application for the TPS3852-Q1 is shown in Figure 20. The TPS3852G33-Q1 is used to monitor the 3.3-V, V<sub>CORE</sub> rail powering the microcontroller.

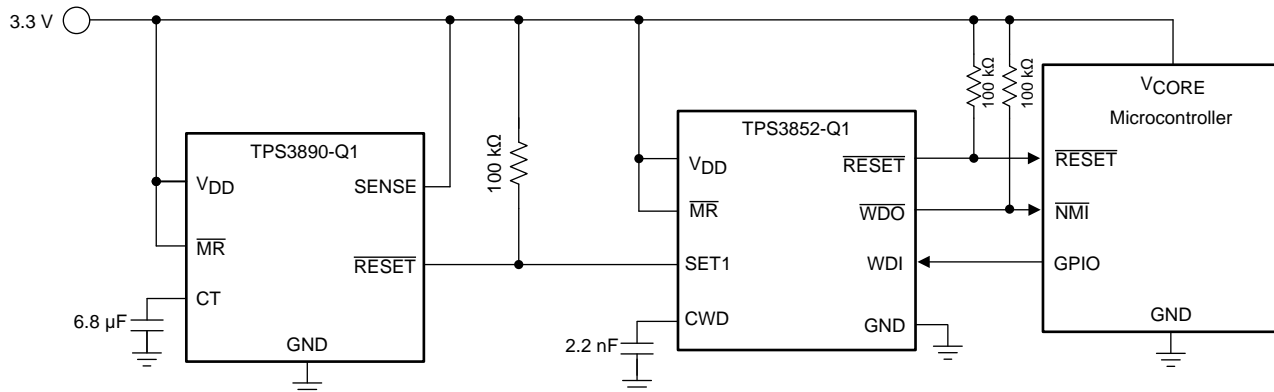

Copyright © 2016, Texas Instruments Incorporated

Figure 20. Monitoring Supply Voltage and Watchdog Supervision of a Microcontroller

### 8.2.1 Design Requirements

PARAMETER	DESIGN REQUIREMENT	DESIGN RESULT
Watchdog disable for initialization period	Watchdog must remain disabled for 7 seconds until logic enables the watchdog timer	7.21 seconds (typ)
Output logic voltage	3.3-V CMOS	3.3-V CMOS
Monitored rail	3.3 V with a 5% threshold	Worst-case V <sub>ITN</sub> = 3.142 V (–4.7% threshold)
Watchdog window	250 ms, maximum	t <sub>WDL(max)</sub> = 135 ms, t <sub>WDU(min)</sub> = 181 ms
Maximum device current consumption	50 μA	52 μA (worst-case) when $\overline{\text{RESET}}$ or $\overline{\text{WDO}}$ is asserted <sup>(1)</sup>

(1) Only includes the TPS3852G33-Q1 current consumption.

### 8.2.2 Detailed Design Procedure

#### 8.2.2.1 Monitoring the 3.3-V Rail

This application calls for very tight monitoring of the rail with only 5% of variation allowed on the rail. To ensure this requirement is met, the TPS3852G33-Q1 was chosen for its –4% threshold. To calculate the worst-case for V<sub>ITN</sub>, the accuracy must also be taken into account. The worst-case for V<sub>ITN</sub> can be calculated by Equation 3:

$$V_{ITN(\text{Worst-Case})} = V_{ITN(\text{typ})} \times 0.992 = 3.3 \times 0.96 \times 0.992 = 3.142 \text{ V} \quad (3)$$

### 8.2.2.2 Calculating $\overline{\text{RESET}}$ and the $\overline{\text{WDO}}$ Pullup Resistor

The TPS3852-Q1 uses an open-drain configuration for the  $\overline{\text{RESET}}$  circuit, as shown in Figure 21. When the FET is off, the resistor pulls the drain of the transistor to VDD and when the FET is turned on, the FET attempts to pull the drain to ground, thus creating an effective resistor divider. The resistors in this divider must be chosen to ensure that  $V_{OL}$  is below the maximum value. To choose the proper pullup resistor, there are three key specifications to keep in mind: the pullup voltage ( $V_{PU}$ ), the recommended maximum  $\overline{\text{RESET}}$  pin current ( $I_{\overline{\text{RESET}}}$ ), and  $V_{OL}$ . The maximum  $V_{OL}$  is 0.4 V, meaning that the effective resistor divider created must be able to bring the voltage on the reset pin below 0.4 V with  $I_{\overline{\text{RESET}}}$  kept below 10 mA. For this example, with a  $V_{PU}$  of 3.3 V, a resistor must be chosen to keep  $I_{\overline{\text{RESET}}}$  below 50  $\mu\text{A}$  because this value is the maximum consumption current allowed. To ensure this specification is met, a pullup resistor value of 100 k $\Omega$  was selected, which sinks a maximum of 33  $\mu\text{A}$  when  $\overline{\text{RESET}}$  or  $\overline{\text{WDO}}$  is asserted. As illustrated in Figure 11, when the  $\overline{\text{RESET}}$  current is at 33  $\mu\text{A}$  the low-level output voltage is approximately zero.

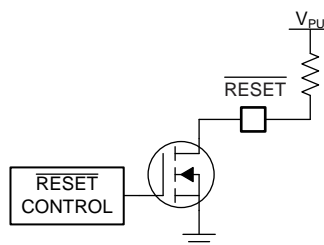

Copyright © 2016, Texas Instruments Incorporated

**Figure 21.  $\overline{\text{RESET}}$  Open-Drain Configuration**

### 8.2.2.3 Setting the Window Watchdog

As illustrated in Figure 18, there are three options for setting the window watchdog. The design specifications in this application require the programmable timing option (external capacitor connected to CWD). When a capacitor is connected to the CWD pin, the window is governed by Equation 4. Equation 4 is only valid for ideal capacitors, any temperature or voltage derating must be accounted for separately.

$$C_{\text{CWD}} (\mu\text{F}) = \frac{t_{\text{WDU}} - 0.055}{77.4} = \frac{0.25 - 0.055}{77.4} = 0.0025 \mu\text{F} \quad (4)$$

The nearest standard capacitor value to 2.5 nF is 2.2 nF. Selecting 2.2 nF for the  $C_{\text{CWD}}$  capacitor gives the following minimum and maximum timing parameters:

$$t_{\text{WDU}(\text{MIN})} = 0.85 \times t_{\text{WDU}(\text{TYP})} = 0.85 \times (77.4 \times 2.2 \times 10^{-3} + 0.055) = 191 \text{ ms} \quad (5)$$

$$t_{\text{WDL}(\text{MAX})} = 0.5 \times t_{\text{WDU}(\text{MAX})} = 0.5 \times [1.15 \times (77.4 \times 2.2 \times 10^{-3} + 0.055)] = 129 \text{ ms} \quad (6)$$

Capacitor tolerance also influence  $t_{\text{WDU}(\text{MIN})}$  and  $t_{\text{WDL}(\text{MAX})}$ . Select a ceramic COG dielectric capacitor for high accuracy. For 2.2 nF, COG capacitors are readily available with a 5% tolerance, which results in a 5% decrease in  $t_{\text{WDU}(\text{MIN})}$  and a 5% increase in  $t_{\text{WDL}(\text{MAX})}$ , giving 181 ms and 135 ms, respectively. A falling edge must be issued within this window.

### 8.2.2.4 Watchdog Disabled During Initialization Period

The watchdog is often needed to be disabled during startup to allow for an initialization period. When the initialization period is over, the watchdog timer is turned back on to allow the microcontroller to be monitored by the TPS3852-Q1. To achieve this setup, SET1 must start at GND. In this design, SET1 is controlled by a TPS3890-Q1 supervisor. In this application, the TPS3890-Q1 was chosen to monitor  $V_{\text{DD}}$  as well, meaning that  $\overline{\text{RESET}}$  on the TPS3890-Q1 stays low until  $V_{\text{DD}}$  rises above  $V_{\text{ITN}}$ . When  $V_{\text{DD}}$  comes up, the delay time can be adjusted through the CT capacitor on the TPS3890-Q1. With this approach, the  $\overline{\text{RESET}}$  delay can be adjusted from a minimum of 25  $\mu\text{s}$  to a maximum of 30 seconds. For this design, a minimum delay of 7 seconds is needed until the watchdog timer is enabled. The CT capacitor calculation (see the TPS3890-Q1 data sheet) yields an ideal capacitance of 6.59  $\mu\text{F}$ , giving a closest standard ceramic capacitor value of 6.8  $\mu\text{F}$ . When connecting a 6.8- $\mu\text{F}$  capacitor from CT to GND, the typical delay time is 7.21 seconds. Figure 22 illustrates the typical startup waveform for this circuit when the watchdog input is off. Figure 22 illustrates that when the watchdog is disabled, the  $\overline{\text{WDO}}$  output remains high. See the TPS3890-Q1 data sheet for detailed information on the TPS3890-Q1.

### 8.2.3 Glitch Immunity

Figure 25 shows the high-to-low glitch immunity for the TPS3852G33-Q1 with a 7% overdrive with  $V_{DD}$  starting at 3.3 V. This curve shows that  $V_{DD}$  can go below the threshold for 5.2  $\mu$ s without RESET asserting.

### 8.2.4 Application Curves

Unless otherwise stated, application curves were taken at  $T_A = 25^\circ\text{C}$ .

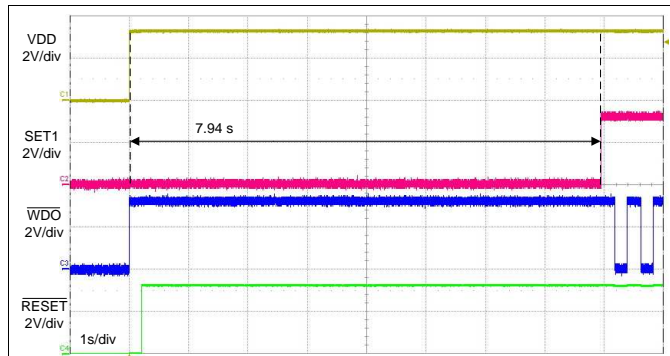

Figure 22. Startup Without a WDI Signal

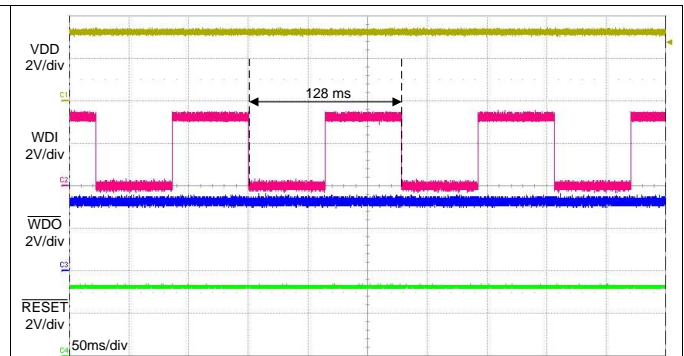

Figure 23. Typical WDI Signal

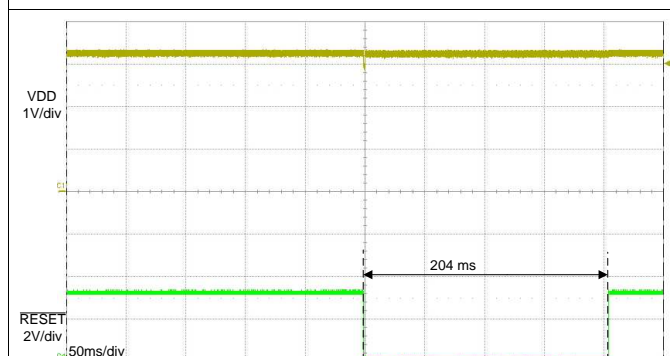

Figure 24. Typical  $\overline{\text{RESET}}$  Delay

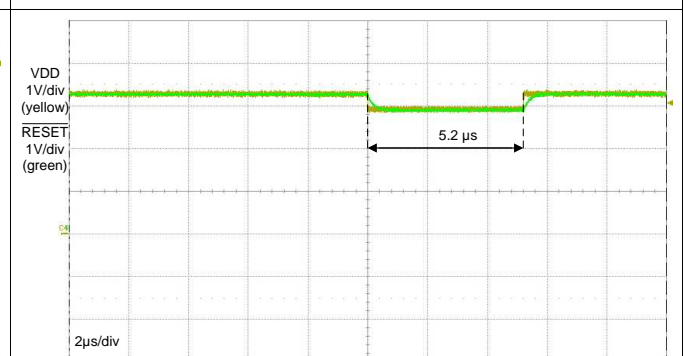

Figure 25. High-to-Low Glitch Immunity

## 9 Power Supply Recommendations

This device is designed to operate from an input supply with a voltage range between 1.6 V and 6.5 V. An input supply capacitor is not required for this device; however, if the input supply is noisy, then good analog practice is to place a 0.1- $\mu$ F capacitor between the VDD pin and the GND pin.

## 10 Layout

### 10.1 Layout Guidelines

- Make sure that the connection to the VDD pin is low impedance. Good analog design practice is to place a 0.1- $\mu$ F ceramic capacitor as near as possible to the VDD pin.
- If a  $C_{CWD}$  capacitor or pull-up resistor is used, place these components as close as possible to the CWD pin. If the CWD pin is left unconnected, make sure to minimize the amount of parasitic capacitance on the pin.
- Place the pullup resistors on  $\overline{\text{RESET}}$  and  $\overline{\text{WDO}}$  as close to the pin as possible.

### 10.2 Layout Example

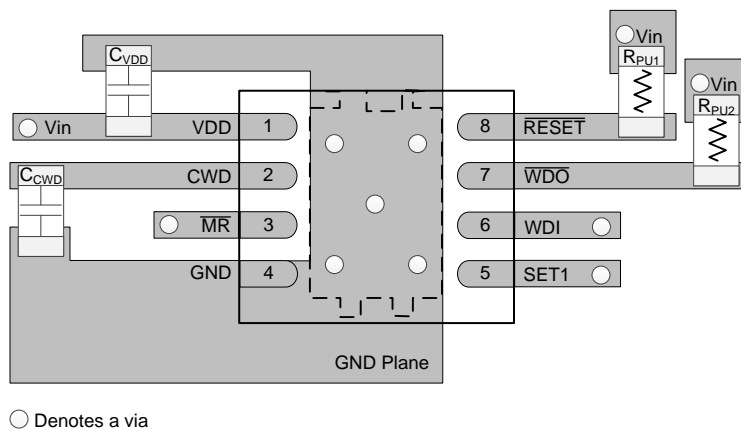

**Figure 26. Typical Layout for the TPS3852-Q1**

## 11 Device and Documentation Support

### 11.1 Device Support

#### 11.1.1 Development Support

##### 11.1.1.1 Evaluation Module

The [TPS3851EVM-780 Evaluation Module](#) can be used to evaluate this part. If this evaluation module is being used, then the device on the EVM must be changed to the TPS3852-Q1.

#### 11.1.2 Device Nomenclature

**Table 5. Device Nomenclature**

DESCRIPTION	NOMENCLATURE	VALUE
TPS3852 (high-accuracy supervisor with window watchdog)	—	—
X (nominal threshold as a percent of the nominal monitored voltage)	G	$V_{ITN} = -4\%$
	H	$V_{ITN} = -7\%$
yy(y) <sup>(1)</sup> (nominal monitored voltage option)	18	1.8 V
	33	3.3 V

(1) For example, the TPS3852G33QDRBQ1 corresponds to a 3.3-V nominal monitored voltage with a –4% nominal threshold.

### 11.2 Receiving Notification of Documentation Updates

To receive notification of documentation updates, navigate to the device product folder on ti.com. In the upper right corner, click on *Alert me* to register and receive a weekly digest of any product information that has changed. For change details, review the revision history included in any revised document.

### 11.3 Community Resources

The following links connect to TI community resources. Linked contents are provided "AS IS" by the respective contributors. They do not constitute TI specifications and do not necessarily reflect TI's views; see TI's [Terms of Use](#).

**TI E2E™ Online Community** *TI's Engineer-to-Engineer (E2E) Community*. Created to foster collaboration among engineers. At e2e.ti.com, you can ask questions, share knowledge, explore ideas and help solve problems with fellow engineers.

**Design Support** *TI's Design Support* Quickly find helpful E2E forums along with design support tools and contact information for technical support.

### 11.4 Trademarks

E2E is a trademark of Texas Instruments.  
All other trademarks are the property of their respective owners.

### 11.5 Electrostatic Discharge Caution



This integrated circuit can be damaged by ESD. Texas Instruments recommends that all integrated circuits be handled with appropriate precautions. Failure to observe proper handling and installation procedures can cause damage.

ESD damage can range from subtle performance degradation to complete device failure. Precision integrated circuits may be more susceptible to damage because very small parametric changes could cause the device not to meet its published specifications.

### 11.6 Glossary

[SLYZ022](#) — *TI Glossary*.

This glossary lists and explains terms, acronyms, and definitions.

## 12 Mechanical, Packaging, and Orderable Information

The following pages include mechanical, packaging, and orderable information. This information is the most current data available for the designated devices. This data is subject to change without notice and revision of this document. For browser-based versions of this data sheet, refer to the left-hand navigation.

**PACKAGING INFORMATION**

Orderable Device	Status (1)	Package Type	Package Drawing	Pins	Package Qty	Eco Plan (2)	Lead/Ball Finish (6)	MSL Peak Temp (3)	Op Temp (°C)	Device Marking (4/5)	Samples
TPS3852G18QDRBRQ1	PREVIEW	SON	DRB	8	3000	Green (RoHS & no Sb/Br)	CU SN	Level-2-260C-1 YEAR	-40 to 125	852DB	
TPS3852G33QDRBRQ1	PREVIEW	SON	DRB	8	3000	Green (RoHS & no Sb/Br)	CU SN	Level-2-260C-1 YEAR	-40 to 125	852GB	
TPS3852H18QDRBRQ1	PREVIEW	SON	DRB	8	3000	Green (RoHS & no Sb/Br)	CU SN	Level-2-260C-1 YEAR	-40 to 125	852LB	
TPS3852H33QDRBRQ1	PREVIEW	SON	DRB	8	3000	Green (RoHS & no Sb/Br)	CU SN	Level-2-260C-1 YEAR	-40 to 125	852PB	

(1) The marketing status values are defined as follows:

**ACTIVE:** Product device recommended for new designs.

**LIFEBUY:** TI has announced that the device will be discontinued, and a lifetime-buy period is in effect.

**NRND:** Not recommended for new designs. Device is in production to support existing customers, but TI does not recommend using this part in a new design.

**PREVIEW:** Device has been announced but is not in production. Samples may or may not be available.

**OBSELETE:** TI has discontinued the production of the device.

(2) Eco Plan - The planned eco-friendly classification: Pb-Free (RoHS), Pb-Free (RoHS Exempt), or Green (RoHS & no Sb/Br) - please check <http://www.ti.com/productcontent> for the latest availability information and additional product content details.

**TBD:** The Pb-Free/Green conversion plan has not been defined.

**Pb-Free (RoHS):** TI's terms "Lead-Free" or "Pb-Free" mean semiconductor products that are compatible with the current RoHS requirements for all 6 substances, including the requirement that lead not exceed 0.1% by weight in homogeneous materials. Where designed to be soldered at high temperatures, TI Pb-Free products are suitable for use in specified lead-free processes.

**Pb-Free (RoHS Exempt):** This component has a RoHS exemption for either 1) lead-based flip-chip solder bumps used between the die and package, or 2) lead-based die adhesive used between the die and leadframe. The component is otherwise considered Pb-Free (RoHS compatible) as defined above.

**Green (RoHS & no Sb/Br):** TI defines "Green" to mean Pb-Free (RoHS compatible), and free of Bromine (Br) and Antimony (Sb) based flame retardants (Br or Sb do not exceed 0.1% by weight in homogeneous material)

(3) MSL, Peak Temp. - The Moisture Sensitivity Level rating according to the JEDEC industry standard classifications, and peak solder temperature.

(4) There may be additional marking, which relates to the logo, the lot trace code information, or the environmental category on the device.

(5) Multiple Device Markings will be inside parentheses. Only one Device Marking contained in parentheses and separated by a "~" will appear on a device. If a line is indented then it is a continuation of the previous line and the two combined represent the entire Device Marking for that device.

(6) Lead/Ball Finish - Orderable Devices may have multiple material finish options. Finish options are separated by a vertical ruled line. Lead/Ball Finish values may wrap to two lines if the finish value exceeds the maximum column width.

**Important Information and Disclaimer:** The information provided on this page represents TI's knowledge and belief as of the date that it is provided. TI bases its knowledge and belief on information provided by third parties, and makes no representation or warranty as to the accuracy of such information. Efforts are underway to better integrate information from third parties. TI has taken and continues to take reasonable steps to provide representative and accurate information but may not have conducted destructive testing or chemical analysis on incoming materials and chemicals. TI and TI suppliers consider certain information to be proprietary, and thus CAS numbers and other limited information may not be available for release.

In no event shall TI's liability arising out of such information exceed the total purchase price of the TI part(s) at issue in this document sold by TI to Customer on an annual basis.

**OTHER QUALIFIED VERSIONS OF TPS3852-Q1 :**

- Catalog: [TPS3852](#)

NOTE: Qualified Version Definitions:

- Catalog - TI's standard catalog product

DRB (S-PVSON-N8)

PLASTIC SMALL OUTLINE NO-LEAD

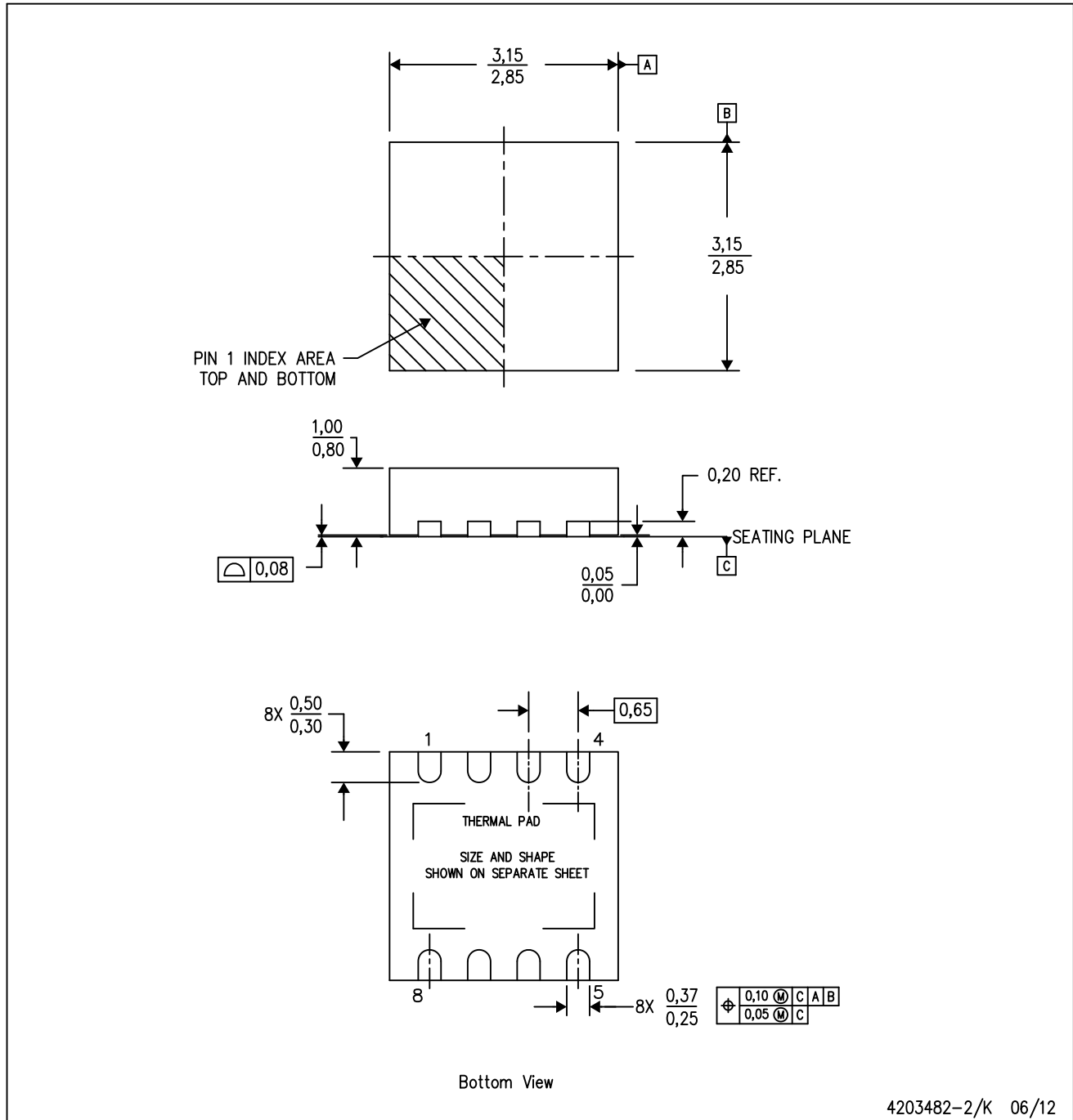

4203482-2/K 06/12

- NOTES:
- All linear dimensions are in millimeters. Dimensioning and tolerancing per ASME Y14.5M-1994.
  - This drawing is subject to change without notice.
  - Small Outline No-Lead (SON) package configuration.
  - The package thermal pad must be soldered to the board for thermal and mechanical performance.
  - See the additional figure in the Product Data Sheet for details regarding the exposed thermal pad features and dimensions.

## IMPORTANT NOTICE FOR TI DESIGN INFORMATION AND RESOURCES

Texas Instruments Incorporated ("TI") technical, application or other design advice, services or information, including, but not limited to, reference designs and materials relating to evaluation modules, (collectively, "TI Resources") are intended to assist designers who are developing applications that incorporate TI products; by downloading, accessing or using any particular TI Resource in any way, you (individually or, if you are acting on behalf of a company, your company) agree to use it solely for this purpose and subject to the terms of this Notice.

TI's provision of TI Resources does not expand or otherwise alter TI's applicable published warranties or warranty disclaimers for TI products, and no additional obligations or liabilities arise from TI providing such TI Resources. TI reserves the right to make corrections, enhancements, improvements and other changes to its TI Resources.

You understand and agree that you remain responsible for using your independent analysis, evaluation and judgment in designing your applications and that you have full and exclusive responsibility to assure the safety of your applications and compliance of your applications (and of all TI products used in or for your applications) with all applicable regulations, laws and other applicable requirements. You represent that, with respect to your applications, you have all the necessary expertise to create and implement safeguards that (1) anticipate dangerous consequences of failures, (2) monitor failures and their consequences, and (3) lessen the likelihood of failures that might cause harm and take appropriate actions. You agree that prior to using or distributing any applications that include TI products, you will thoroughly test such applications and the functionality of such TI products as used in such applications. TI has not conducted any testing other than that specifically described in the published documentation for a particular TI Resource.

You are authorized to use, copy and modify any individual TI Resource only in connection with the development of applications that include the TI product(s) identified in such TI Resource. NO OTHER LICENSE, EXPRESS OR IMPLIED, BY ESTOPPEL OR OTHERWISE TO ANY OTHER TI INTELLECTUAL PROPERTY RIGHT, AND NO LICENSE TO ANY TECHNOLOGY OR INTELLECTUAL PROPERTY RIGHT OF TI OR ANY THIRD PARTY IS GRANTED HEREIN, including but not limited to any patent right, copyright, mask work right, or other intellectual property right relating to any combination, machine, or process in which TI products or services are used. Information regarding or referencing third-party products or services does not constitute a license to use such products or services, or a warranty or endorsement thereof. Use of TI Resources may require a license from a third party under the patents or other intellectual property of the third party, or a license from TI under the patents or other intellectual property of TI.

TI RESOURCES ARE PROVIDED "AS IS" AND WITH ALL FAULTS. TI DISCLAIMS ALL OTHER WARRANTIES OR REPRESENTATIONS, EXPRESS OR IMPLIED, REGARDING TI RESOURCES OR USE THEREOF, INCLUDING BUT NOT LIMITED TO ACCURACY OR COMPLETENESS, TITLE, ANY EPIDEMIC FAILURE WARRANTY AND ANY IMPLIED WARRANTIES OF MERCHANTABILITY, FITNESS FOR A PARTICULAR PURPOSE, AND NON-INFRINGEMENT OF ANY THIRD PARTY INTELLECTUAL PROPERTY RIGHTS.

TI SHALL NOT BE LIABLE FOR AND SHALL NOT DEFEND OR INDEMNIFY YOU AGAINST ANY CLAIM, INCLUDING BUT NOT LIMITED TO ANY INFRINGEMENT CLAIM THAT RELATES TO OR IS BASED ON ANY COMBINATION OF PRODUCTS EVEN IF DESCRIBED IN TI RESOURCES OR OTHERWISE. IN NO EVENT SHALL TI BE LIABLE FOR ANY ACTUAL, DIRECT, SPECIAL, COLLATERAL, INDIRECT, PUNITIVE, INCIDENTAL, CONSEQUENTIAL OR EXEMPLARY DAMAGES IN CONNECTION WITH OR ARISING OUT OF TI RESOURCES OR USE THEREOF, AND REGARDLESS OF WHETHER TI HAS BEEN ADVISED OF THE POSSIBILITY OF SUCH DAMAGES.

You agree to fully indemnify TI and its representatives against any damages, costs, losses, and/or liabilities arising out of your non-compliance with the terms and provisions of this Notice.

This Notice applies to TI Resources. Additional terms apply to the use and purchase of certain types of materials, TI products and services. These include; without limitation, TI's standard terms for semiconductor products (<http://www.ti.com/sc/docs/stdterms.htm>), [evaluation modules](#), and [samples](http://www.ti.com/sc/docs/sampterm.htm) (<http://www.ti.com/sc/docs/sampterm.htm>).

Mailing Address: Texas Instruments, Post Office Box 655303, Dallas, Texas 75265  
Copyright © 2017, Texas Instruments Incorporated