

- **Accurate, Easy-to-Use Alternative to Piezoresistive Accelerometers**
- **Capacitive Micromachined**
- **Nitrogen Damped**
- **±4V Differential Output or 0.5V to 4.5V Single Ended Output**
- **Fully Calibrated**
- **Low Power Consumption**
- **-55 to +85°C Operation**
- **+8 to +32V DC Power**
- **Simple Four Wire Connection**
- **Low Impedance Outputs Will Drive Up To 15 Meters of Cable**
- **Responds to DC and AC Acceleration**
- **Non Standard g Ranges Available**
- **Rugged Anodized Aluminum Module**
- **Low Noise**
- **Serialized for Traceability**

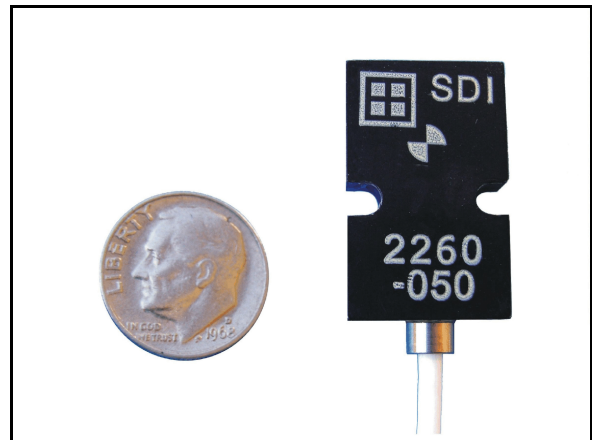

**ORDERING INFORMATION**

Full Scale Acceleration	Model Number
± 2 g	2260-002
± 5 g	2260-005
± 10 g	2260-010
± 25 g	2260-025
± 50 g	2260-050
±100 g	2260-100
±200 g	2260-200

**DESCRIPTION**

The P-Cap™ model 2260 accelerometer module combines an integrated model 1221L accelerometer with high drive, low impedance buffering for measuring acceleration in commercial/industrial environments. It is tailored for zero to medium frequency instrumentation applications. The anodized aluminum case is epoxy sealed and is easily mounted via two #4 (or M3) screws. On-board regulation is provided to minimize the effects of supply voltage variation. It is relatively insensitive to temperature changes and thermal gradients. The cable's shield is electrically connected to the case while the ground (GND) wire is isolated from the case. An optional initial calibration sheet (2260-CAL) and periodic calibration checking are also available.

**OPERATION**

The P-Cap™ Model 2260 accelerometer module produces two analog voltage outputs which vary with acceleration as shown in the graph on the next page. The sensitive axis is perpendicular to the bottom of the package, with positive acceleration defined as a force pushing on the bottom of the package. The signal outputs are fully differential about a common mode voltage of approximately 2.5 volts. The output scale factor is independent from the supply voltage of +8 to +32 volts. At zero acceleration the output differential voltage is nominally 0 volts DC; at ±full scale acceleration the output differential voltage is ±4 volts DC respectively.

**APPLICATIONS**

- FLIGHT TESTS
- VIBRATION MONITORING
- VIBRATION ANALYSIS
- MACHINE CONTROL
- MODAL ANALYSIS
- ROBOTICS
- CRASH TESTING
- INSTRUMENTATION

P-Cap is a trademark of Silicon Designs, Inc.

## SIGNAL DESCRIPTIONS

**Vs and GND (Power):** Red and Black wires respectively. Power (+9 to +32 Volts DC) and ground.

**AOP and AON (Output):** Green and White wires respectively. Analog output voltages proportional to acceleration; AOP voltage increases (AON decreases) with positive acceleration. At zero acceleration both outputs are nominally equal to 2.5 volts. The device experiences positive (+1g) acceleration with its lid facing up in the Earth's gravitational field. Either output can be used individually or the two outputs can be used differentially. (See output response plot below)

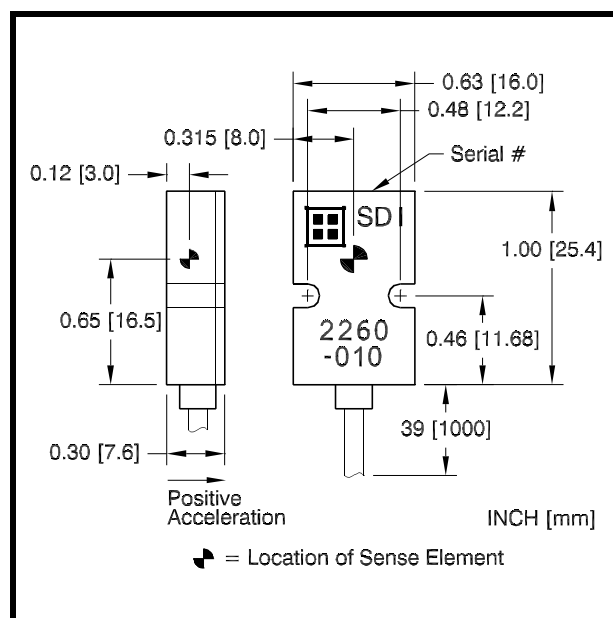
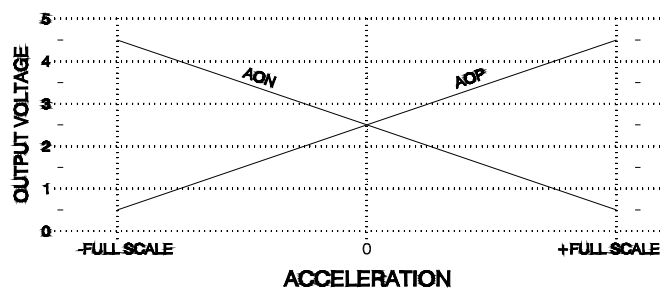

<b>PERFORMANCE - By Model:</b> $V_s=+8$ to +32VDC, $T_c=25^\circ\text{C}$									
MODEL NUMBER	2260-002	2260-005	2260-010	2260-025	2260-050	2260-100	2260-200	UNITS	
Input Range	±2	±5	±10	±25	±50	±100	±200	g	
Frequency Response (Nominal, 3 dB) <sup>1</sup>	0 - 400	0 - 600	0 - 1000	0 - 1500	0 - 2000	0 - 2500	0 - 2500	Hz	
Sensitivity, Differential <sup>2</sup>	2000	800	400	160	80	40	20	mV/g	
Output Noise, Differential (RMS, typical)	13	32	63	158	316	632	1265	µg/(root Hz)	
Max. Mechanical Shock (0.1 ms)	2000								g

Note 1: 250Hz ±100Hz, -3dB bandwidth, optionally available.

Note 2: Single ended sensitivity is half of values shown.

<b>PERFORMANCE - All Models:</b> Unless otherwise specified, $V_s=+8$ to +32VDC, $T_c=25^\circ\text{C}$ , Differential Mode.					
PARAMETER	MIN	TYP	MAX	UNITS	
Cross Axis Sensitivity		2	3	%	
Bias Calibration Error	-002	2	4	% of span	
	-005 thru -200	2	3		
Bias Temperature Shift ( $T_c = -40$ to $+80^\circ\text{C}$ )	-002 & -005	100	300	(ppm of span)/°C	
	-010 thru -200	50	200		
Scale Factor Calibration Error <sup>3</sup>		2	3	%	
Scale Factor Temperature Shift ( $T_c = -40$ to $+80^\circ\text{C}$ )	-250		+250	ppm/°C	
Non-Linearity (-90 to +90% of Full Scale) <sup>3, 4</sup>	-002 thru -050	0.15	0.5	% of span	
	-100	0.25	1.0		
	-200	0.40	1.5		
Power Supply Rejection Ratio	50	>65		dB	
Output Impedance		1		Ω	
Output Common Mode Voltage		2.5		VDC	
Operating Voltage	8		32	VDC	
Operating Current (AOP & AON open)		9	12	mA DC	
Mass (not including cable)		6		grams	
Cable Mass		14		grams/meter	

Note 3: 100g versions and above are tested from -65g to +65g.

Note 4: Tighter tolerances available upon request.

**CABLE SPECIFICATIONS & LENGTH CONSIDERATIONS**

The cable consists of four 28 AWG (7x36) silver plated copper wires with PTFE insulation surrounded by a braided shield. The shield jacket is a PTFE tape wrap with a nominal outer diameter of 0.096". Cable lengths of up to 15 meters (50 feet) can be added to the model 2260's standard 1 meter cable without the need to test for output instability. For lengths longer than 15 meters we recommend you check each individual installation for oscillation by tapping the accelerometer and watching the differential output for oscillation in the 20kHz to 50kHz region. If no oscillation is present then the cable length being used is OK. From the standpoint of output current drive and slew rate limitations, the model 2260 is capable of driving over 600 meters (2000 feet) of its cable type but at some length between 15 and 600 meters, each device will likely begin to exhibit oscillation.

**CONVERTING THE 2260's DIFFERENTIAL OUTPUT TO SINGLE ENDED**

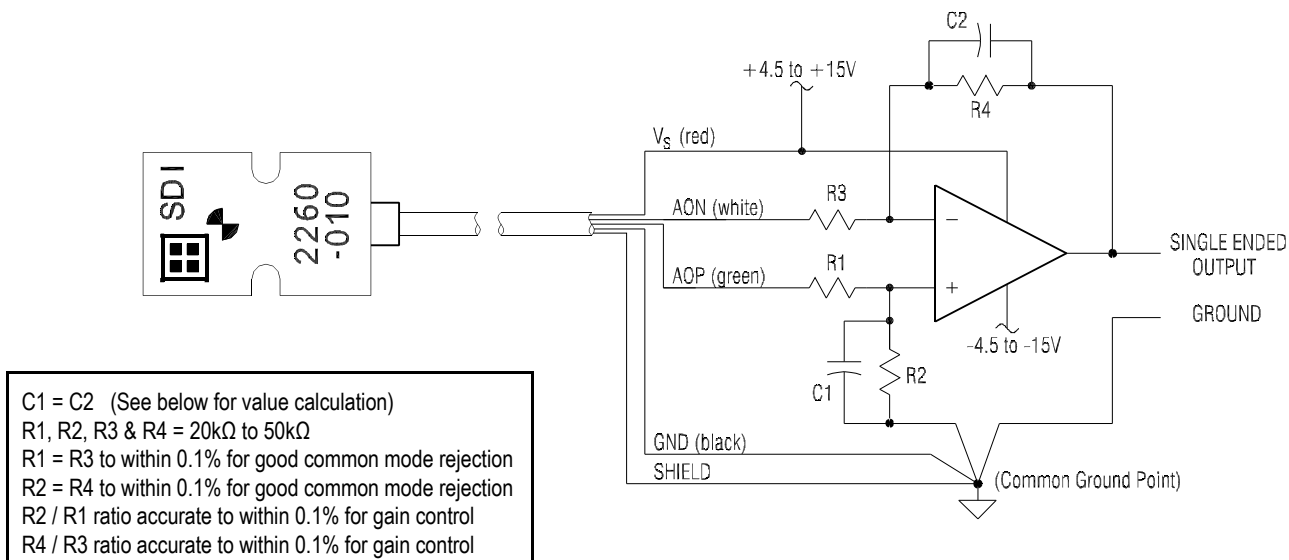

To achieve the highest resolution and lowest noise performance from your model 2260 accelerometer module, it should be connected to your voltage measurement instrument in a differential configuration using both the **AOP** and **AON** output signals. If your measurement instrument lacks differential input capability or you desire to use a differential input capable instrument in single ended mode, then the circuit above can be used to preserve the low noise performance of the model 2260 while using a single ended type connection.

This circuit converts the ± 4 Volt differential output of the model 2260 accelerometer, centered at +2.5 Volts, to a single ended output centered about ground (0.0 Volts). It provides the advantage of low common mode noise by preventing the accelerometer's ground current from causing an error in the voltage reading.

The op-amp should be located as close as possible to your voltage monitoring equipment so that the majority of the signal path is differential. Any noise present along the differential path will affect both wires to the same degree and the op-amp will reject this noise because it is a common mode signal. The op-amp type is not critical; a μA741 or ¼ of a LM124 can be used. Both plus and minus supplies are needed for the op-amp to accommodate the positive and negative swings of the single ended output.

For this design, always set  $R_1 = R_3$ ,  $R_2 = R_4$  and  $C_1 = C_2$ . The gain of the circuit is then determined by the ratio  $R_2/R_1$ . When  $R_1 = R_2 = R_3 = R_4$ , the gain equals 1 and the output swing will be ± 4 Volts single ended with respect to ground. To obtain a ± 5 Volt single ended output, set  $R_2/R_1 = R_4/R_3 = 5/4 = 1.25$ . The single ended output of the op-amp will be centered at ground if  $R_2$  and  $C_1$  are tied to ground; using some other fixed voltage for this reference will shift the output. The value of the optional capacitors  $C_1$  and  $C_2$  ( $C_1 = C_2$ ) can be selected to roll off the frequency response to the frequency range of interest. The cutoff frequency  $f_0$  (-3 dB frequency) for this single order low pass filter is given by:

$$f_0 = \frac{1}{2\pi R_2 C_1}$$