

Z2075Q-K Technical Data Sheet



Technical Data	
Fluid	chilled or hot water, up to 60% glycol
Flow characteristic	equal percentage
Controllable flow range	75°
Valve Size [mm]	0.75" [20]
Pipe connection	NPT female ends
Housing	forged brass
Ball	chrome plated brass
Stem	brass
Seat	PTFE
O-ring	EPDM (lubricated)
Body Pressure Rating	360 psi
Maximum Allowable Operating Temperature	212°F [100°C] *
Close-off pressure Δps	75 psi
Cv	9.8
Weight	0.44 lb [0.20 kg]
Fluid Temp Range (water)	36...212°F [2...100°C]
Leakage rate	0%
Servicing	maintenance-free

* If temperature exceeds 212°F operating range due to a boiler control failure the valve will safely contain the hot water but manufacturers product warranty becomes invalid. Valve and actuator replacement is at the expense of others.

Application

The QCV zone valves are suited for large commercial buildings where higher close-off and the ability to change flow is desired. Common applications include unit ventilators, fan coil units, VAV reheat coils, fin tube casing, radiant panels and duct coils. The valve fits in space restricted areas and can be assembled without the use of tools.

Suitable Actuators

	Non-Spring	Electronic fail-safe
Z2075Q-K	CQB	CQKB(X)

Dimensions (Inches [mm])

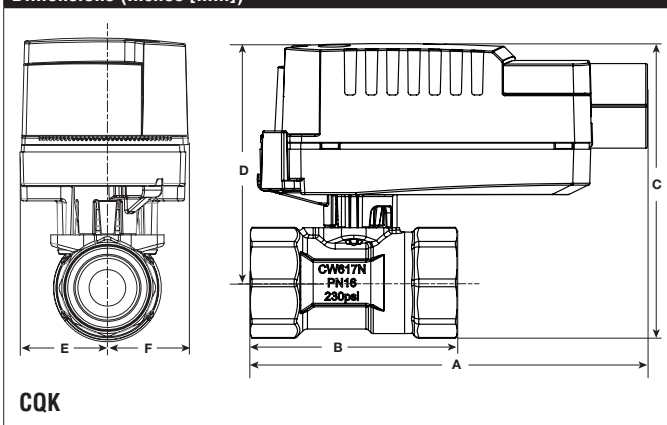

A	B	C	D	E	F
4.5" [114]	2.4" [60]	3.4" [87]	2.8" [70]	0.9" [24]	

Safety Notes

WARNING: This product can expose you to lead which is known to the State of California to cause cancer and reproductive harm. For more information go to www.p65warnings.ca.gov

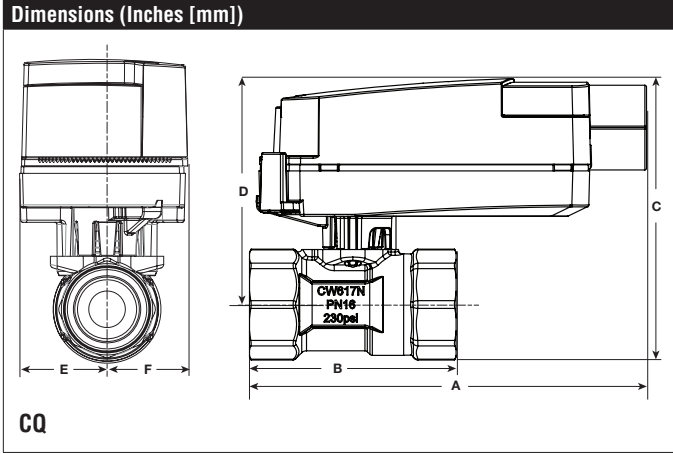

A	B	C	D	E	F
4.5" [114]	2.4" [60]	3.3" [83]	2.6" [65]	1.2" [30]	1.2" [31]