

## DLPA3000 PMIC and High-Current LED Driver IC

### 1 Features

- High-Efficiency, High-Current RGB LED Driver
- Integrated Buck Converter Enables up to 6-A LED Driver Current
- RGB MOSFET Switches for Channel Selection With Very Low On-Resistance
- 10-Bit Programmable Current per Channel
- Inputs for Selecting Color-Sequential RGB LEDs
- Generation of DMD High-Voltage Supplies
- Two High-Efficiency Buck Converters to Generate the DLPC343x and DMD Supply
- Three High-Efficiency, 8-Bit Programmable Buck Converters for FAN Driver Application or General Power Supply (PWR6 currently supported, others will be available in the future)
- Two LDOs Supplying Auxiliary Voltages
- Analog MUX for Measuring Internal and External Nodes (such as a thermistor and reference levels)
- Monitoring/Protections: Thermal Shutdown, Hot Die, Low-Battery, and Undervoltage Lockout

### 2 Applications

Portable DLP® Pico™ Projectors

### 3 Description

The DLPA3000 is a highly-integrated power management IC optimized for DLP Pico Projector systems. The device is targeting accessory applications up to several hundreds of lumen.

The DLPA3000 supports LED projectors up to 6 A per LED, enabled by an integrated high efficiency buck converter. On top of that, the low-ohmic RGB switches support the sequencing of red, green, and blue LEDs. The DLPA3000 contains five buck converters with two dedicated for DLPC low-voltage supplies. Another dedicated regulating supply generates the three timing-critical DC supplies for the DMD:  $V_{BIAS}$ ,  $V_{RST}$ , and  $V_{OFS}$ .

The DLPA3000 contains several auxiliary blocks which can be used in a flexible way. This enables a tailor-made Pico Projector system. Three 8-bit programmable buck converters (not all supported yet) can be used, for example, to drive the projector FANs or to make auxiliary supply lines. Two LDOs can be used for a lower-current supply of up to 200 mA. These LDOs are pre-defined to 2.5 V and 3.3 V.

Through the SPI, all blocks of the DLPA3000 can be addressed. Features included are the generation of the system reset, power sequencing, input signals for sequentially selecting the active LED, IC self-protections, and an analog MUX for routing analog information to an external ADC.

#### Device Information<sup>(1)</sup>

PART NUMBER	PACKAGE	BODY SIZE (NOM)
DLPA3000	HTQFP (100)	14.00 mm × 14.00 mm

(1) For all available packages, see the orderable addendum at the end of the data sheet.

#### Block Diagram

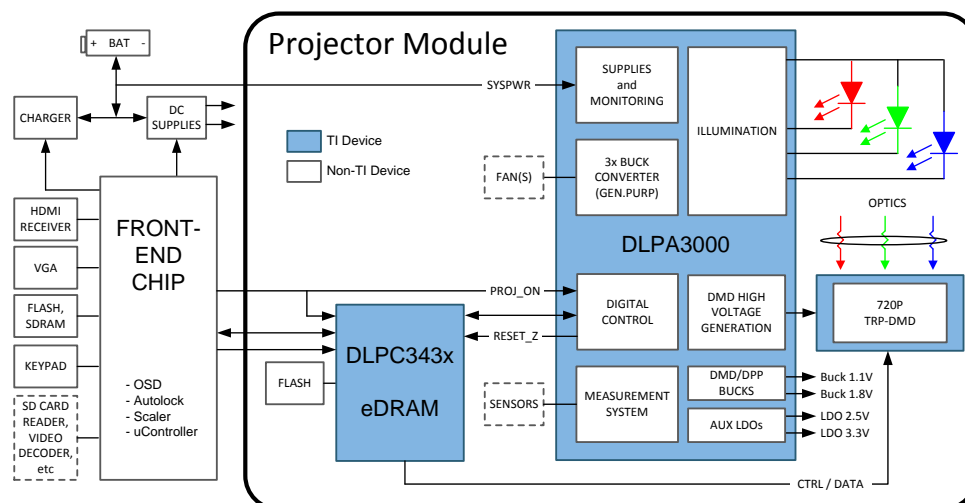

## Table of Contents

<b>1 Features</b> .....	<b>1</b>	8.1 Application Information.....	<b>57</b>
<b>2 Applications</b> .....	<b>1</b>	8.2 Typical Applications .....	<b>57</b>
<b>3 Description</b> .....	<b>1</b>	<b>9 Power Supply Recommendations</b> .....	<b>60</b>
<b>4 Revision History</b> .....	<b>2</b>	<b>10 Layout</b> .....	<b>61</b>
<b>5 Pin Configuration and Functions</b> .....	<b>3</b>	10.1 Layout Guidelines .....	<b>61</b>
<b>6 Specifications</b> .....	<b>7</b>	10.2 Layout Example .....	<b>61</b>
6.1 Absolute Maximum Ratings .....	<b>7</b>	10.3 SPI Connections .....	<b>62</b>
6.2 ESD Ratings.....	<b>8</b>	10.4 R <sub>LIM</sub> Routing.....	<b>63</b>
6.3 Recommended Operating Conditions .....	<b>8</b>	10.5 LED Connection.....	<b>63</b>
6.4 Thermal Information .....	<b>8</b>	10.6 Thermal Considerations .....	<b>65</b>
6.5 Electrical Characteristics.....	<b>9</b>	<b>11 Device and Documentation Support</b> .....	<b>68</b>
6.6 SPI Timing Parameters .....	<b>15</b>	11.1 Device Support.....	<b>68</b>
<b>7 Detailed Description</b> .....	<b>16</b>	11.2 Related Links .....	<b>68</b>
7.1 Overview .....	<b>16</b>	11.3 Community Resources.....	<b>68</b>
7.2 Functional Block Diagram .....	<b>16</b>	11.4 Trademarks .....	<b>69</b>
7.3 Feature Description.....	<b>16</b>	11.5 Electrostatic Discharge Caution .....	<b>69</b>
7.4 Device Functional Modes.....	<b>45</b>	11.6 Glossary .....	<b>69</b>
7.5 Register Maps .....	<b>48</b>	<b>12 Mechanical, Packaging, and Orderable Information</b> .....	<b>69</b>
<b>8 Application and Implementation</b> .....	<b>57</b>		

## 4 Revision History

DATE	REVISION	NOTES
October 2015	*	Initial release.

## 5 Pin Configuration and Functions

**PFD Package  
100-Pin HTQFP  
Top View**

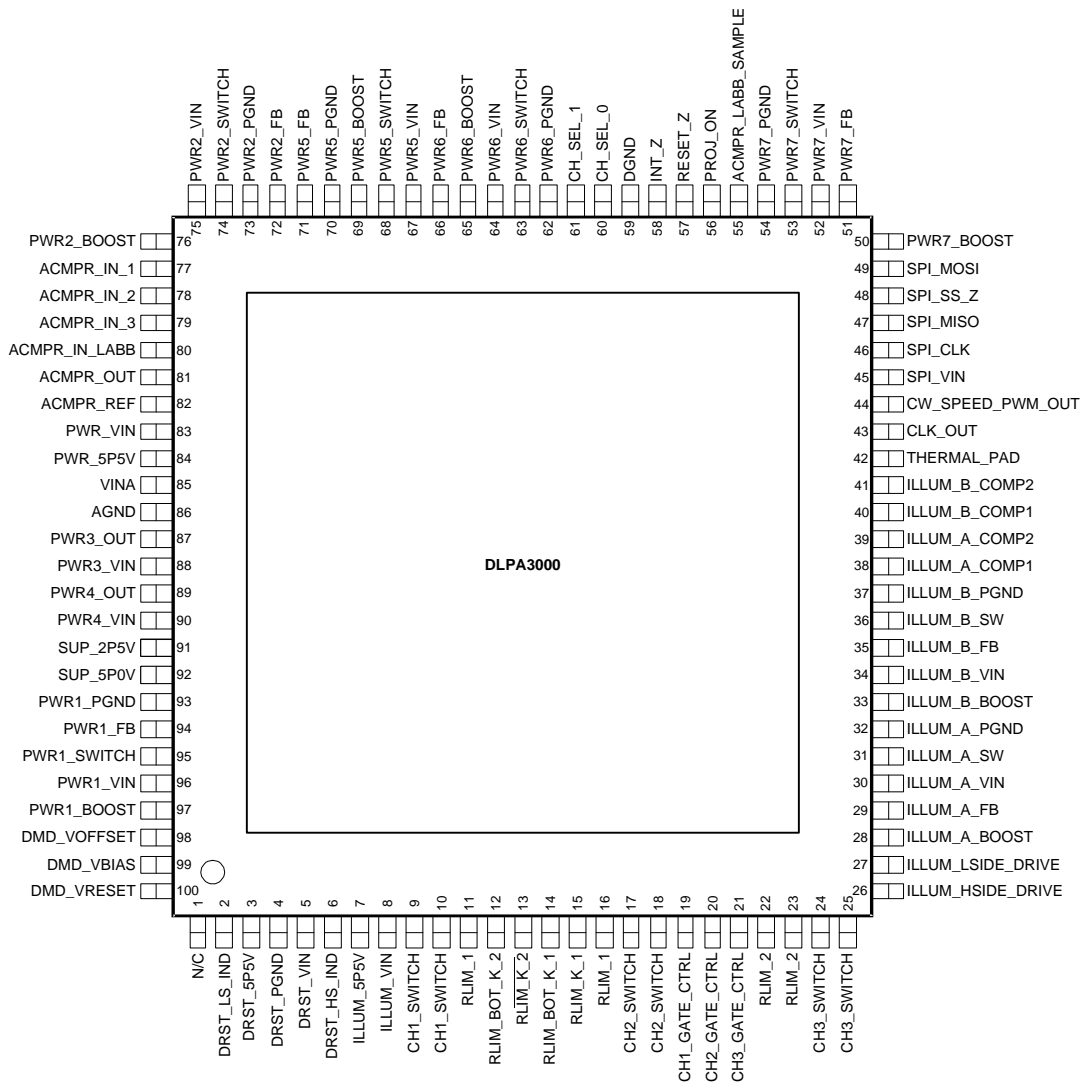

### Pin Functions

PIN		I/O	DESCRIPTION
NAME	NO.		
N/C	1	–	No connect
DRST_LS_IND	2	I/O	Connection for the DMD SMPS-inductor (low-side switch).
DRST_5P5V	3	O	Filter pin for LDO DMD. Power supply for internal DMD reset regulator, typical 5.5 V.
DRST_PGND	4	GND	Power ground for DMD SMPS. Connect to ground plane.
DRST_VIN	5	POWER	Power supply input for LDO DMD. Connect to system power.
DRST_HS_IND	6	I/O	Connection for the DMD SMPS-inductor (high-side switch).
ILLUM_5P5 V	7	O	Filter pin for LDO ILLUM. Power supply for internal ILLUM block, typical 5.5 V.
ILLUM_VIN	8	POWER	Supply input of LDO ILLUM. Connect to system power.
CH1_SWITCH	9	I	Low-side MOSFET switch for LED Cathode. Connect to RGB LED assembly.
CH1_SWITCH	10	I	Low-side MOSFET switch for LED Cathode. Connect to RGB LED assembly.
RLIM_1	11	O	Connection to LED current sense resistor for CH1 and CH2.
RLIM_BOT_K_2	12	I	Kelvin sense connection to ground side of LED current sense resistor.
RLIM_K_2	13	I	Kelvin sense connection to top side of current sense resistor.
RLIM_BOT_K_1	14	I	Kelvin sense connection to ground side of LED current sense resistor.
RLIM_K_1	15	I	Kelvin sense connection to top side of current sense resistor.
RLIM_1	16	O	Connection to LED current sense resistor for CH1 and CH2.
CH2_SWITCH	17	I	Low-side MOSFET switch for LED cathode. Connect to RGB LED assembly.
CH2_SWITCH	18	I	Low-side MOSFET switch for LED cathode. Connect to RGB LED assembly.
CH1_GATE_CTRL	19	O	Gate control of CH1 external MOSFET switch for LED cathode.
CH2_GATE_CTRL	20	O	Gate control of CH2 external MOSFET switch for LED cathode.
CH3_GATE_CTRL	21	O	Gate control of CH3 external MOSFET switch for LED cathode.
RLIM_2	22	O	Connection to LED current sense resistor for CH3.
RLIM_2	23	O	Connection to LED current sense resistor for CH3.
CH3_SWITCH	24	I	Low-side MOSFET switch for LED Cathode. Connect to RGB LED assembly.
CH3_SWITCH	25	I	Low-side MOSFET switch for LED Cathode. Connect to RGB LED assembly.
ILLUM_HSIDE_DRIVE	26	O	Gate control for external high-side MOSFET for ILLUM Buck converter.
ILLUM_LSIDE_DRIVE	27	O	Gate control for external low-side MOSFET for ILLUM Buck converter.
ILLUM_A_BOOST	28	I	Supply voltage for high-side N-channel MOSFET gate driver. A 100 nF capacitor (typical) must be connected between this pin and ILLUM_A_SW.
ILLUM_A_FB	29	I	Input to the buck converter loop controlling $I_{LED}$ .
ILLUM_A_VIN	30	POWER	Power input to the ILLUM Driver A.
ILLUM_A_SW	31	I/O	Switch node connection between high-side NFET and low-side NFET. Serves as common connection for the flying high side FET driver.
ILLUM_A_PGND	32	GND	Ground connection to the ILLUM Driver A.
ILLUM_B_BOOST	33	I	Supply voltage for high-side N-channel MOSFET gate driver.
ILLUM_B_VIN	34	POWER	Power input to the ILLUM driver B.
ILLUM_B_FB	35	I	Input to the buck converter loop controlling $I_{LED}$ .
ILLUM_B_SW	36	I/O	Switch node connection between high-side NFET and low-side NFET.
ILLUM_B_PGND	37	GND	Ground connection to the ILLUM driver B.
ILLUM_A_COMP1	38	I/O	Connection node for feedback loop components
ILLUM_A_COMP2	39	I/O	Connection node for feedback loop components
ILLUM_B_COMP1	40	I/O	Connection node for feedback loop components
ILLUM_B_COMP2	41	I/O	Connection node for feedback loop components
THERMAL_PAD	42	GND	Thermal pad. Connect to clean system ground.
CLK_OUT	43	O	Color wheel clock output
CW_SPEED_PWM_OUT	44	O	Color wheel PWM output
SPI_VIN	45	I	Supply for SPI interface

**Pin Functions (continued)**

PIN		I/O	DESCRIPTION
NAME	NO.		
SPI_CLK	46	I	SPI clock input
SPI_MISO	47	O	SPI data output
SPI_SS_Z	48	I	SPI chip select (active low)
SPI_MOSI	49	I	SPI data input
PWR7_BOOST	50	I	Charge-pump-supply input for the high-side FET gate drive circuit. Connect 100 nF capacitor between PWR7_BOOST and PWR7_SWITCH pins.
PWR7_FB	51	I	Converter feedback input. Connect to converter output voltage.
PWR7_VIN	52	POWER	Power supply input for converter.
PWR7_SWITCH	53	I/O	Switch node connection between high-side NFET and low-side NFET.
PWR7_PGND	54	GND	Ground pin. Power ground return for switching circuit.
ACMPR_LABB_SAMPLE	55	I	Control signal to sample voltage at ACMPR_IN_LABB.
PROJ_ON	56	I	Input signal to enable/disable the IC and DLP projector.
RESET_Z	57	O	Reset output to the DLP system (active low). Pin is held low to reset DLP system.
INT_Z	58	O	Interrupt output signal (open drain, active low). Connect to pull-up resistor.
DGND	59	GND	Digital ground. Connect to ground plane.
CH_SEL_0	60	I	Control signal to enable either of CH1,2,3.
CH_SEL_1	61	I	Control signal to enable either of CH1,2,3.
PWR6_PGND	62	GND	Ground pin. Power ground return for switching circuit.
PWR6_SWITCH	63	I/O	Switch node connection between high-side NFET and low-side NFET.
PWR6_VIN	64	POWER	Power supply input for converter.
PWR6_BOOST	65	I	Charge-pump-supply input for the high-side FET gate drive circuit. Connect 100 nF capacitor between PWR6_BOOST and PWR6_SWITCH pins.
PWR6_FB	66	I	Converter feedback input. Connect to output voltage.
PWR5_VIN	67	POWER	Power supply input for converter.
PWR5_SWITCH	68	I/O	Switch node connection between high-side NFET and low-side NFET.
PWR5_BOOST	69	I	Charge-pump-supply input for the high-side FET gate drive circuit. Connect 100nF capacitor between PWR5_BOOST and PWR5_SWITCH pins.
PWR5_PGND	70	GND	Ground pin. Power ground return for switching circuit.
PWR5_FB	71	I	Converter feedback input. Connect to output voltage.
PWR2_FB	72	I	Converter feedback input. Connect to output voltage.
PWR2_PGND	73	GND	Ground pin. Power ground return for switching circuit.
PWR2_SWITCH	74	I/O	Switch node connection between high-side NFET and low-side NFET.
PWR2_VIN	75	POWER	Power supply input for converter.
PWR2_BOOST	76	I	Charge-pump-supply input for the high-side FET gate drive circuit. Connect 100 nF capacitor between PWR2_BOOST and PWR2_SWITCH pins.
ACMPR_IN_1	77	I	Input for analog sensor signal.
ACMPR_IN_2	78	I	Input for analog sensor signal.
ACMPR_IN_3	79	I	Input for analog sensor signal.
ACMPR_IN_LABB	80	I	Input for ambient light sensor, sampled input
ACMPR_OUT	81	O	Analog comparator out
ACMPR_REF	82	I	Reference voltage input for analog comparator
PWR_VIN	83	POWER	Power supply input for LDO_Bucks. Connect to system power.
PWR_5P5V	84	O	Filter pin for LDO_BUCKS. Internal analog supply for buck converters, typical 5.5 V.
VINA	85	POWER	Input voltage supply pin for Reference system.
AGND	86	GND	Analog ground pin.
PWR3_OUT	87	O	Filter pin for LDO_2 DMD/DLPC/AUX, typical 2.5 V.
PWR3_VIN	88	POWER	Power supply input for LDO_2. Connect to system power.

**Pin Functions (continued)**

PIN		I/O	DESCRIPTION
NAME	NO.		
PWR4_OUT	89	O	Filter pin for LDO_1 DMD/DLPC/AUX, typical 3.3 V.
PWR4_VIN	90	POWER	Power supply input for LDO_1. Connect to system power.
SUP_2P5V	91	O	Filter pin for LDO_V2V5. Internal supply voltage, typical 2.5 V.
SUP_5P0V	92	O	Filter pin for LDO_V5V. Internal supply voltage, typical 5 V.
PWR1_PGND	93	GND	Ground pin. Power ground return for switching circuit.
PWR1_FB	94	I	Converter feedback input. Connect to output voltage.
PWR1_SWITCH	95	I/O	Switch node connection between high-side NFET and low-side NFET.
PWR1_VIN	96	POWER	Power supply input for converter.
PWR1_BOOST	97	I	Charge-pump-supply input for the high-side FET gate drive circuit. Connect 100nF capacitor between PWR1_BOOST and PWR1_SWITCH pins.
DMD_VOFFSET	98	O	VOFS output rail. Connect to ceramic capacitor.
DMD_VBIAS	99	O	VBIAS output rail. Connect to ceramic capacitor.
DMD_VRESET	100	O	VRESET output rail. Connect to ceramic capacitor.

## 6 Specifications

### 6.1 Absolute Maximum Ratings

over operating free-air temperature (unless otherwise noted) <sup>(1)</sup>

		MIN	MAX	UNIT
Voltage	ILLUM_A,B_BOOST	-0.3	28	V
	ILLUM_A,B_BOOST (10 ns transient)	-0.3	30	
	ILLUM_A,B_BOOST vs ILLUM_A,B_SWITCH	-0.3	7	
	ILLUM_LSIDE_DRIVE	-0.3	7	
	ILLUM_HSIDE_DRIVE	-2	28	
	ILLUM_A_BOOST vs ILLUM_HSIDE_DRIVE	-0.3	7	
	ILLUM_A,B_SW	-2	22	
	ILLUM_A,B_SW (10 ns transient)	-3	27	
	PWR_VIN, PWR1,2,3,4,5,6,7_VIN, VINA, ILLUM_VIN, ILLUM_A,B_VIN, DRST_VIN	-0.3	22	
	PWR1,2,5,6,7_BOOST	-0.3	28	
	PWR1,2,5,6,7_BOOST (10 ns transient)	-0.3	30	
	PWR1,2,5,6,7_SWITCH	-2	22	
	PWR1,2,5,6,7_SWITCH (10 ns transient)	-3	27	
	PWR1,2,5,6,7_FB	-0.3	6.5	
	PWR1,2,5,6,7_BOOST vs PWR1,2,5,6,7_SWITCH	-0.3	6.5	
	CH1,2,3_SWITCH, DRST_LS_IND, ILLUM_A,B_FB	-0.3	20	
	ILLUM_A,B_COMP1,2, INT_Z, PROJ_ON	-0.3	7	
	DRST_HS_IND	-18	7	
	ACMPR_IN_1,2,3, ACMPR_REF, ACMPR_IN_LABB, ACMPR_LABB_SAMPLE, ACMPR_OUT	-0.3	3.6	
	SPI_VIN, SPI_CLK, SPI_MOSI, SPI_SS_Z, SPI_MISO, CH_SEL_0,1, RESET_Z	-0.3	3.6	
	RLIM_K_1,2, RLIM_1,2	-0.3	3.6	
	DGND, AGND, DRST_PGND, ILLUM_A,B_PGND, PWR1,2,5,6,7_PGND, RLIM_BOT_K_1,2	-0.3	0.3	
	DRST_5P5V, ILLUM_5P5V, PWR_5P5, PWR3,4_OUT, SUP_5P0V	-0.3	7	
	CH1,2,3_GATE_CTRL	-0.3	7	
	CLK_OUT	-0.3	3.6	
	CW_SPEED_PWM	-0.3	7	
	SUP_2P5V	-0.3	3.6	
	DMD_VOFFSET	-0.3	12	
	DMD_VBIAS	-0.3	20	
	DMD_VRESET	-18	7	
Source current	RESET_Z, ACMPR_OUT		1	mA
	SPI_DOUT		5.5	
Sink current	RESET_Z, ACMPR_OUT		1	mA
	SPI_DOUT, INT_Z		5.5	
T <sub>stg</sub>	Storage temperature	-65	150	°C

(1) Stresses beyond those listed under *Absolute Maximum Ratings* may cause permanent damage to the device. These are stress ratings only, which do not imply functional operation of the device at these or any other conditions beyond those indicated under *Recommended Operating Conditions*. Exposure to absolute-maximum-rated conditions for extended periods may affect device reliability.

## 6.2 ESD Ratings

		VALUE	UNIT
$V_{(ESD)}$ <sup>(1)</sup>	Electrostatic discharge	Human-body model (HBM), per ANSI/ESDA/JEDEC JS-001, all pins <sup>(2)</sup>	±2000
		Charged-device model (CDM), per JEDEC specification JESD22-C101, all pins <sup>(3)</sup>	±500

- (1) Electrostatic discharge (ESD) to measure device sensitivity and immunity to damage caused by assembly line electrostatic discharges in to the device.
- (2) JEDEC document JEP155 states that 500 V HBM allows safe manufacturing with a standard ESD control process.
- (3) JEDEC document JEP157 states that 250 V CDM allows safe manufacturing with a standard ESD control process.

## 6.3 Recommended Operating Conditions

over operating free-air temperature range (unless otherwise noted)

		MIN	MAX	UNIT	
$V_I$	Input voltage	PWR_VIN, PWR1,2,3,4,5,6,7_VIN, VINA, ILLUM_VIN, ILLUM_A,B_VIN, DRST_VIN	6	20	V
		CH1,2,3_SWITCH, ILLUM_A,B_FB,	-0.1	6.3	
		INT_Z, PROJ_ON	-0.1	6	
		PWR1,2,5,6,7_FB	-0.1	5	
		ACMPR_REF, CH_SEL_0,1, SPI_CLK, SPI_MOSI, SPI_SS_Z	-0.1	3.6	
		RLIM_BOT_K_1,2	-0.1	0.1	
		ACMPR_IN_1,2,3, LABB_IN_LABB	-0.1	1.5	
		SPI_VIN	1.7	3.6	
		RLIM_K_1,2	-0.1	0.25	
		ILLUM_A,B_COMP1,2	-0.1	5.7	
$T_A$	Ambient temperature	0	70	°C	
$T_J$	Operating junction temperature	0	120	°C	

## 6.4 Thermal Information

THERMAL METRIC <sup>(1)</sup>		DLPA3000	UNIT
		HTQFP (PFD)	
		100 PINS	
$R_{\theta JA}$	Junction-to-ambient thermal resistance <sup>(2)</sup>	7.0	°C/W
$R_{\theta JC(top)}$	Junction-to-case (top) thermal resistance <sup>(3)</sup>	0.7	°C/W
$\Psi_{JT}$	Junction-to-top characterization parameter <sup>(4)</sup>	0.6	°C/W
$\Psi_{JB}$	Junction-to-board characterization parameter <sup>(5)</sup>	3.4	°C/W

- (1) For more information about traditional and new thermal metrics, see the *Semiconductor and IC Package Thermal Metrics* application report ([SPRA953](#)).
- (2) The junction-to-ambient thermal resistance under natural convection is obtained in a simulation on a JEDEC-standard, high-K board, but since the device is intended to be cooled with a heatsink from the top case of the package, the simulation includes a fan and heatsink attached to the DLPA3000. The heatsink is a 22 mm × 22 mm × 12 mm aluminum pin fin heatsink with a 12 × 12 × 3 mm stud. Base thickness is 2 mm and pin diameter is 1.5 mm with an array of 6 × 6 pins. The heatsink is attached to the DLPA3000 with 100 um thick thermal grease with 3 W/m-K thermal conductivity. The fan is 20 × 20 × 8 mm with 1.6 cfm open volume flow rate and 0.22 in. water pressure at stagnation.
- (3) The junction-to-case (top) thermal resistance is obtained by simulating a cold plate test on the package top. No specific JEDEC standard test exists, but a close description can be found in the ANSI SEMI standard G30-88.
- (4) The junction-to-top characterization parameter,  $\Psi_{JT}$ , estimates the junction temperature of a device in a real system and is extracted from the simulation data for obtaining  $R_{\theta JA}$ , using a procedure described in JESD51-2a (sections 6 and 7), but modified to include the fan and heatsink described in note 2.
- (5) The junction-to-board characterization parameter,  $\Psi_{JB}$ , estimates the junction temperature of a device in a real system and is extracted from the simulation data for obtaining  $R_{\theta JA}$ , using a procedure described in JESD51-2a (sections 6 and 7), but modified to include the fan and heatsink described in note 2.

## 6.5 Electrical Characteristics

over operating free-air temperature range.  $V_{IN} = 12\text{ V}$ ,  $T_A = 0$  to  $+70^\circ\text{C}$ , typical values are at  $T_A = 25^\circ\text{C}$ , configuration according to [Typical Applications](#) ( $V_{IN} = 12\text{ V}$ ,  $I_{OUT} = 6\text{ A}$ , LED, internal FETs) (unless otherwise noted).

PARAMETER		TEST CONDITIONS	MIN	TYP	MAX	UNIT
<b>SUPPLIES</b>						
<b>INPUT VOLTAGE</b>						
$V_{IN}$	Input voltage range	VINA – pin	6 <sup>(1)</sup>	12	20	V
$V_{LOW\_BAT}$	Low battery warning threshold	VINA falling (via 5 bit trim function)	3.9		18.4	V
	Hysteresis	VINA rising		90		mV
$V_{UVLO}$	UVLO threshold	VINA falling (via 5 bit trim function)	3.9		18.4	V
	Hysteresis	VINA rising		90		mV
$V_{STARTUP}$	Startup voltage	DMD_VBIAS, DMD_VOFFSET, DMD_VRESET loaded with 10 mA	6			V
<b>INPUT CURRENT</b>						
$I_{IDLE}$	Idle current	IDLE mode, all VIN pins combined		15		$\mu\text{A}$
$I_{STD}$	Standby current	STANDBY mode, analog, internal supplies and LDOs enabled, DMD, ILLUMINATION and BUCK CONVERTERS disabled.		3.7		mA
$I_{Q\_DMD}$	Quiescent current (DMD)	Quiescent current DMD block (in addition to $I_{STD}$ ) with DMD type TRP, VINA + DRST_VIN		0.49		mA
$I_{Q\_ILLUM}$	Quiescent current (ILLUM)	Quiescent current ILLUM block (in addition to $I_{STD}$ ) in 6 A LED configuration, internal FETs, $V_{openloop} = 3\text{ V}$ (0x18, ILLUM_OLV_SEL), VINA + ILLUM_VIN + ILLUM_A_VIN + ILLUM_B_VIN		21		mA
$I_{Q\_BUCK}$	Quiescent current (per BUCK)	Quiescent current per BUCK converter (in addition to $I_{STD}$ ), Normal mode, VINA + PWR_VIN + PWR1,2,5,6,7_VIN, PWR1,2,5,6,7_VOUT = 1 V		4.3		mA
		Quiescent current per BUCK converter (in addition to $I_{STD}$ ), Normal mode, VINA + PWR_VIN + PWR1,2,5,6,7_VIN, PWR1,2,5,6,7_VOUT = 5 V		15		
		Quiescent current per BUCK converter (in addition to $I_{STD}$ ), Cycle-skipping mode, VINA + PWR_VIN + PWR1,2,5,6,7_VIN = 1 V		0.41		
		Quiescent current per BUCK converter (in addition to $I_{STD}$ ), Cycle-skipping mode, VINA + PWR_VIN + PWR1,2,5,6,7_VIN = 5 V		0.46		
$I_{Q\_TOTAL}$	Quiescent current (Total)	Typical Application: 6 A LED, Internal FETs, DMD type TRP. ACTIVE mode, all VIN pins combined, DMD, ILLUMINATION and PWR1,2 enabled, PWR3,4,5,6,7 disabled.		38		mA
<b>INTERNAL SUPPLIES</b>						
$V_{SUP\_5P0V}$	Internal supply, analog			5		V
$V_{SUP\_2P5V}$	Internal supply, logic			2.5		V

- (1)  $V_{IN}$  must be higher than the UVLO voltage setting, including after accounting for AC noise on  $V_{IN}$ , for the DLPA3000 to fully operate. While 6.0 V is the min  $V_{IN}$  voltage supported, TI recommends that the UVLO is never set below 6.21 V. 6.21 V gives margin above 6.0 V to protect against the case where someone suddenly removes  $V_{IN}$ 's power supply which causes the  $V_{IN}$  voltage to drop rapidly. Failure to keep  $V_{IN}$  above 6.0 V before the mirrors are parked and  $V_{OFS}$ ,  $V_{RST}$ , and  $V_{BIAS}$  supplies are properly shut down can result in permanent damage to the DMD. Since 6.21 V is 0.21 V above 6.0 V, when UVLO trips there is time for the DLPA3000 and DLPC343x to park the DMD mirrors and do a fast shut down of supplies  $V_{OFS}$ ,  $V_{RST}$ , and  $V_{BIAS}$ . For whatever UVLO setting is used, if  $V_{IN}$ 's power supply is suddenly removed enough bulk capacitance should be included on  $V_{IN}$  inside the projector to keep  $V_{IN}$  above 6.0 V for at least 100 $\mu\text{s}$  after UVLO trips.

**Electrical Characteristics (continued)**

over operating free-air temperature range.  $V_{IN} = 12\text{ V}$ ,  $T_A = 0\text{ to }+70^\circ\text{C}$ , typical values are at  $T_A = 25^\circ\text{C}$ , configuration according to [Typical Applications](#) ( $V_{IN} = 12\text{ V}$ ,  $I_{OUT} = 6\text{ A}$ , LED, internal FETs) (unless otherwise noted).

PARAMETER		TEST CONDITIONS	MIN	TYP	MAX	UNIT
<b>DMD - LDO DMD</b>						
$V_{DRST\_VIN}$			6	12	20	V
$V_{DRST\_5P5V}$				5.5		V
PGOOD	Power good DRST_5P5V	Rising		80%		
		Falling		60%		
OVP	Overvoltage protection DRST_5P5V			7.2		V
	Regulator dropout	At 25 mA, $V_{DRST\_VIN} = 5.5\text{ V}$		56		mV
	Regulator current limit <sup>(2)</sup>		300	340	400	mA
<b>DMD - REGULATOR</b>						
$R_{DS(ON)}$	MOSFET ON-resistance	Switch A (from DRST_5P5V to DRST_HS_IND)		920		mΩ
		Switch B (from DRST_LS_IND to DRST_PGND)		450		
$V_{FW}$	Forward voltage drop	Switch C (from DRST_LS_IND to DRST_VBIAS <sup>(2)</sup> ), $V_{DRST\_LS\_IND} = 2\text{ V}$ , $I_F = 100\text{ mA}$		1.21		V
		Switch D (from DRST_LS_IND to DRST_VOFFSET <sup>(2)</sup> ), $V_{DRST\_LS\_IND} = 2\text{ V}$ , $I_F = 100\text{ mA}$		1.22		
$t_{DIS}$	Rail Discharge time	$C_{OUT} = 1\text{ }\mu\text{F}$			40	μs
$t_{PG}$	Power-good timeout	Not tested in production		15		ms
$I_{LIMIT}$	Switch current limit	DMD type TRP		610		mA
<b>VOFFSET REGULATOR</b>						
$V_{OFFSET}$	Output voltage	DMD type TRP		10		V
	DC output voltage accuracy	DMD type TRP, $I_{OUT} = 10\text{ mA}$	-0.3		0.3	V
	DC Load regulation	DMD type TRP, $I_{OUT} = 0\text{ to }10\text{ mA}$		-10		V/A
	DC Line regulation	DMD type TRP, $I_{OUT} = 10\text{ mA}$ , $DRST\_VIN = 8\text{ V to }20\text{ V}$		-5		mV/V
$V_{RIPPLE}$	Output ripple	DMD type TRP, $I_{OUT} = 10\text{ mA}$ , $C_{OUT} = 1\text{ }\mu\text{F}$		200		mVpp
$I_{OUT}$	Output current	DMD type TRP	0.1		10	mA
PGOOD	Power-good threshold (fraction of nominal output voltage)	VOFFSET rising		86%		
		VOFFSET falling		66%		
C	Output capacitor	DMD type TRP, recommended value (use same value as output capacitor on VRESET)	1			μF
		$t_{DISCHARGE} < 40\text{ }\mu\text{s}$ at $V_{IN} = 8\text{ V}$			1	
<b>VBIAS REGULATOR</b>						
$V_{BIAS}$	Output voltage	DMD type TRP		18		V
	DC output voltage accuracy	DMD type TRP, $I_{OUT} = 10\text{ mA}$	-0.3		0.3	V
	DC Load regulation	DMD type TRP, $I_{OUT} = 0\text{ to }10\text{ mA}$		-18		V/A
	DC Line regulation	DMD type TRP, $I_{OUT} = 10\text{ mA}$ , $DRST\_VIN = 8\text{ V to }20\text{ V}$		-3		mV/V
$V_{RIPPLE}$	Output ripple	DMD type TRP, $I_{OUT} = 10\text{ mA}$ , $C_{OUT} = 470\text{ nF}$		200		mVpp
$I_{OUT}$	Output current	DMD type TRP	0.1		10	mA
PGOOD	Power-good threshold (fraction of nominal output voltage)	VBIAS rising		86%		
		VBIAS falling		66%		

(2) Including rectifying diode.

**Electrical Characteristics (continued)**

over operating free-air temperature range.  $V_{IN} = 12\text{ V}$ ,  $T_A = 0\text{ to }+70^\circ\text{C}$ , typical values are at  $T_A = 25^\circ\text{C}$ , configuration according to [Typical Applications](#) ( $V_{IN} = 12\text{ V}$ ,  $I_{OUT} = 6\text{ A}$ , LED, internal FETs) (unless otherwise noted).

PARAMETER	TEST CONDITIONS	MIN	TYP	MAX	UNIT			
C	Output capacitor	DMD type TRP, recommended value (use same or smaller value as output capacitors VOFFSET / VRESET)			470	nF		
		$t_{DISCHARGE} < 40\ \mu\text{s}$ at $V_{IN} = 8\text{ V}$			470			
<b>VRESET REGULATOR</b>								
$V_{RST}$	Output voltage	DMD type TRP			-14	V		
	DC output voltage accuracy	DMD type TRP, $I_{OUT} = 10\text{ mA}$			-0.3	0.3	V	
	DC Load regulation	DMD type TRP, $I_{OUT} = 0\text{ to }10\text{ mA}$			-4		V/A	
	DC Line regulation	DMD type TRP, $I_{OUT} = 10\text{ mA}$ , $DRST\_VIN = 8\text{ to }20\text{ V}$			-2		mV/V	
$V_{RIPPLE}$	Output ripple	DMD type TRP, $I_{OUT} = 10\text{ mA}$ , $C_{OUT} = 1\ \mu\text{F}$			120		mVpp	
$I_{OUT}$	Output current	DMD type TRP			0.1	10	mA	
PGOOD	Power-good threshold				90%			
C	Output capacitor	DMD type TRP, recommended value (use same value as output capacitor on VOFFSET)			1	$\mu\text{F}$		
		$t_{DISCHARGE} < 40\ \mu\text{s}$ at $V_{IN} = 8\text{ V}$			1			
<b>DMD - BUCK CONVERTERS</b>								
<b>OUTPUT VOLTAGE</b>								
$V_{PWR\_1\_VOUT}$	Output Voltage	DMD type TRP			1.1	V		
$V_{PWR\_2\_VOUT}$	Output Voltage	DMD type TRP			1.8	V		
	DC output voltage accuracy	DMD type TRP, $I_{OUT} = 0\text{ mA}$			-3%	3%		
<b>MOSFET</b>								
$R_{ON,H}$	High side switch resistance	$25^\circ\text{C}$ , $V_{PWR\_1,2\_Boost} - V_{PWR1,2\_SWITCH} = 5.5\text{ V}$			150	$\text{m}\Omega$		
$R_{ON,L}$	Low side switch resistance <sup>(3)</sup>	$25^\circ\text{C}$			85	$\text{m}\Omega$		
<b>LOAD CURRENT</b>								
	Allowed load current <sup>(4)</sup> .				3	A		
$I_{OCL}$	Current limit <sup>(3)</sup>	$L_{OUT} = 3.3\ \mu\text{H}$			3.2	3.6	4.2	A
<b>ON-TIME TIMER CONTROL</b>								
$t_{ON}$	On time	$V_{IN} = 12\text{ V}$ , $V_O = 5\text{ V}$			120		ns	
$t_{OFF(MIN)}$	Minimum off time <sup>(3)</sup>	$T_A = 25^\circ\text{C}$ , $V_{FB} = 0\text{ V}$			270		ns	
<b>START-UP</b>								
	Soft start				1	2.5	4	ms
<b>PGOOD</b>								
Ratio <sub>OV</sub>	Overvoltage protection				120%			
Ratio <sub>PG</sub>	Relative power good level	Low to High			72%			
<b>ILLUMINATION - LDO ILLUM</b>								
$V_{ILLUM\_VIN}$					6	12	20	V
$V_{ILLUM\_5P5V}$						5.5		V
PGOOD	Power good ILLUM_5P5V	Rising			80%			
		Falling			60%			
OVP	Overvoltage protection ILLUM_5P5V				7.2		V	
	Regulator dropout	At 25 mA, $V_{ILLUM\_VIN} = 5.5\text{ V}$			53		mV	
	Regulator current limit <sup>(3)</sup>				300	340	400	mA

(3) Not production tested.

(4) Care should be taken not to exceed the max power dissipation. Please refer to [Thermal Considerations](#).

## Electrical Characteristics (continued)

over operating free-air temperature range.  $V_{IN} = 12\text{ V}$ ,  $T_A = 0\text{ to }+70^\circ\text{C}$ , typical values are at  $T_A = 25^\circ\text{C}$ , configuration according to [Typical Applications](#) ( $V_{IN} = 12\text{ V}$ ,  $I_{OUT} = 6\text{ A}$ , LED, internal FETs) (unless otherwise noted).

PARAMETER		TEST CONDITIONS	MIN	TYP	MAX	UNIT
<b>ILLUMINATION - DRIVER A,B</b>						
$V_{ILLUM\_A,B\_IN}$	Input supply voltage range		6	12	20	V
<b>PWM</b>						
$f_{SW}$	Oscillator frequency	$3\text{ V} < V_{IN} < 20\text{ V}$		600		kHz
$t_{DEAD}$	Output driver dead time	HDRV off to LDRV on, TRDLY = 0		28		ns
		HDRV off to LDRV on, TRDLY = 1		40		
		LDRV off to HDRV on, TRDLY = 0		35		
<b>MAXIMUM CURRENTS</b>						
HSD OC	High-side drive over current	Internal switches, $I_{DS}$ threshold, single buck (6 A use case).		9.5		A
LSD MC	Low-side drive maximum allowed current	Both directions In or Out. Internal switches, $I_{DS}$ threshold, single buck (6 A use case)		9.5		A
<b>BOOT DIODE</b>						
$V_{DFWD}$	Bootstrap diode forward voltage	$I_{BOOT} = 5\text{ mA}$		0.75		V
<b>PGOOD</b>						
RatioUV	Undervoltage protection			89%		
<b>POWER FETs</b>						
$R_{ON}$	Power FETs	High-Side, $T_A = 25^\circ\text{C}$ , $V_{ILLUM\_A,B\_BOOST} - I_{ILLUM\_A,B\_SW} = 5.5\text{ V}$		150		m $\Omega$
		Low-side, $T_A = 25^\circ\text{C}$		85		
<b>RGB STROBE CONTROLLER SWITCHES</b>						
$R_{ON}$	ON-resistance	CH1,2,3_SWITCH		30	45	m $\Omega$
$I_{LEAK}$	OFF-state leakage current	$V_{DS} = 5.0\text{ V}$			0.1	$\mu\text{A}$
<b>LED CURRENT CONTROL</b>						
$V_{LED\_ANODE}$	LED anode voltage <sup>(3)</sup>	Ratio with respect to $V_{ILLUM\_A,B\_VIN}$ (Duty cycle limitation).	0.85x			V
					6.3	
$I_{LED}$	LED currents	$V_{ILLUM\_A,B\_VIN} \geq 8\text{ V}$ . See register SWx_IDAC[9:0] for settings.	300		6000	mA
	DC current offset, CH1,2,3_SWITCH	$R_{LIM} = 25\text{ m}\Omega$	-75	0	75	mA
	Transient LED current limit range (programmable)	20% higher than $I_{LED}$ . Min-setting, $R_{LIM} = 25\text{ m}\Omega$ .	0.67			A
		20% higher than $I_{LED}$ . Max-setting, $R_{LIM} = 25\text{ m}\Omega$ .	8			
$t_{RISE}$	Current rise time	$I_{LED}$ from 5% to 95%, $I_{LED} = 300\text{ mA}$ , transient current limit disabled <sup>(3)</sup> .			50	$\mu\text{s}$
<b>BUCK CONVERTERS - LDO_BUCKS</b>						
$V_{PWR\_VIN}$	Input voltage range PWR1,2,5,6,7_VIN		6	12	20	V
$V_{PWR\_5P5V}$	PWR_5P5V			5.5		V
PGOOD	Power good PWR_5P5V	Rising		80%		
		Falling		60%		
OVP	Overvoltage Protection PWR_5P5V			7.2		V
	Regulator dropout	At 25 mA, $V_{PWR\_VIN} = 5.5\text{ V}$		41		mV
	Regulator current limit <sup>(2)</sup>		300	340	400	mA

## Electrical Characteristics (continued)

over operating free-air temperature range.  $V_{IN} = 12\text{ V}$ ,  $T_A = 0\text{ to }+70^\circ\text{C}$ , typical values are at  $T_A = 25^\circ\text{C}$ , configuration according to [Typical Applications](#) ( $V_{IN} = 12\text{ V}$ ,  $I_{OUT} = 6\text{ A}$ , LED, internal FETs) (unless otherwise noted).

PARAMETER	TEST CONDITIONS	MIN	TYP	MAX	UNIT		
<b>BUCK CONVERTERS - GENERAL PURPOSE BUCK CONVERTERS <sup>(5)</sup></b>							
<b>OUTPUT VOLTAGE</b>							
$V_{PWR\_5,6,7\_VOUT}$	Output voltage (General purpose buck1,2,3)	8-bit programmable		1	5	V	
	DC output voltage accuracy	$I_{OUT} = 0\text{ mA}$		-3.5%	3.5%		
<b>MOSFET</b>							
$R_{ON,H}$	High side switch resistance	25°C, $V_{PWR5,6,7\_Boost} - V_{PWR5,6,7\_SWITCH} = 5.5\text{ V}$		150		mΩ	
$R_{ON,L}$	Low side switch resistance <sup>(3)</sup>	25°C		85		mΩ	
<b>LOAD CURRENT</b>							
	Allowed load current PWR6 <sup>(4)</sup> .			2		A	
	Allowed load current PWR5, PWR7 <sup>(4)</sup> .	Buck converters should not be used at this time, they will become available in the future.				A	
$I_{OCL}$	Current limit <sup>(3)(4)</sup>	$L_{OUT} = 3.3\text{ }\mu\text{H}$		3.2	3.6	4.2	A
<b>ON-TIME TIMER CONTROL</b>							
$t_{ON}$	On time	$V_{IN} = 12\text{ V}$ , $V_O = 5\text{ V}$		120		ns	
$t_{OFF(MIN)}$	Minimum off time <sup>(3)</sup>	$T_A = 25^\circ\text{C}$ , $V_{FB} = 0\text{ V}$		270	310	ns	
<b>START-UP</b>							
	Soft start			1	2.5	4	ms
<b>PGOOD</b>							
Ratio <sub>OV</sub>	Overvoltage protection			120%			
Ratio <sub>PG</sub>	Relative power good level	Low to high		72%			
<b>AUXILIARY LDOs</b>							
$V_{PWR3,4\_VIN}$	Input voltage range	LDO1 (PWR4), LDO2 (PWR3)		3.3	12	20	V
PGOOD	Power good PWR3,4_VOUT	PWR3,4_VOUT rising		80%			
		PWR3,4_VOUT falling		60%			
OVP	Overvoltage protection PWR3,4_VOUT			7		V	
	DC output voltage accuracy PWR3,4_VOUT	$I_{OUT} = 0\text{ mA}$		-3%	3%		
	Regulator current limit <sup>(3)</sup>			300	340	400	mA
$t_{ON}$	Turn-on time	to 80% of $V_{OUT} = \text{PWR3}$ and $\text{PWR4}$ , $C = 1\text{ }\mu\text{F}$		40		μs	
<b>LDO2 (PWR3)</b>							
$V_{PWR3\_VOUT}$	Output voltage PWR3_VOUT			2.5		V	
	Load current capability			200		mA	
	DC load regulation PWR3_VOUT	$V_{OUT} = 2.5\text{ V}$ , $I_{OUT} = 5\text{ to }200\text{ mA}$		-70		mV/A	
	DC line regulation PWR3_VOUT	$V_{OUT} = 2.5\text{ V}$ , $I_{OUT} = 5\text{ mA}$ , $PWR3\_VIN = 3.3\text{ to }20\text{ V}$		30		μV/V	
<b>LDO1 (PWR4)</b>							
$V_{PWR4\_VOUT}$	Output voltage PWR4_VOUT			3.3		V	
	Load current capability			200		mA	
	DC load regulation PWR4_VOUT	$V_{OUT} = 3.3\text{ V}$ , $I_{OUT} = 5\text{ to }200\text{ mA}$		-70		mV/A	
	DC line regulation PWR4_VOUT	$V_{OUT} = 3.3\text{ V}$ , $I_{OUT} = 5\text{ mA}$ , $PWR4\_VIN = 4\text{ to }20\text{ V}$		30		μV/V	

(5) General Purpose Buck2 (PWR6) currently supported, others will be available in the future.

**Electrical Characteristics (continued)**

over operating free-air temperature range.  $V_{IN} = 12\text{ V}$ ,  $T_A = 0\text{ to }+70^\circ\text{C}$ , typical values are at  $T_A = 25^\circ\text{C}$ , configuration according to [Typical Applications](#) ( $V_{IN} = 12\text{ V}$ ,  $I_{OUT} = 6\text{ A}$ , LED, internal FETs) (unless otherwise noted).

PARAMETER	TEST CONDITIONS	MIN	TYP	MAX	UNIT	
Regulator dropout	At 25 mA, $V_{OUT} = 3.3\text{ V}$ , $V_{PWR4\_VIN} = 3.3\text{ V}$		48		mV	
<b>MEASUREMENT SYSTEM</b>						
<b>AFE</b>						
G	Amplifier gain (PGA)	AFE_GAIN[1:0] = 01		1	V/V	
		AFE_GAIN[1:0] = 10		9.5		
		AFE_GAIN[1:0] = 11		18		
$V_{OFS}$	Input referred offset voltage	PGA, AFE_CAL_DIS = 1 <sup>(3)</sup>		-1	1	mV
		Comparator <sup>(3)</sup>		-1.5	+1.5	
$T_{RC}$	Settling time	To 1% of final value <sup>(3)</sup> .		46	67	$\mu\text{s}$
		To 0.1% of final value <sup>(3)</sup> .		69	100	
$V_{ACMPR\_IN\_1,2,3}$	Input voltage Range ACMPR_IN_1,2,3		0	1.5	V	
<b>LABB</b>						
$T_{RC}$	Settling time	To 1% of final value <sup>(3)</sup> .		4.6	6.6	$\mu\text{s}$
		To 0.1% of final value <sup>(3)</sup> .		7	10	
$V_{ACMPR\_IN\_LABB}$	Input voltage range ACMPR_IN_LABB		0	1.5	V	
	Sampling window ACMPR_IN_LABB	Programmable per 7 $\mu\text{s}$		7	28	$\mu\text{s}$
<b>COLOR WHEEL PWM</b>						
CLK_OUT	Clock output frequency		2.25		MHz	
$V_{CW\_SPEED\_PWM\_OUT}$	Voltage range CW_SPEED_PWM_OUT	Average value programmable in 16 bits		0	5	V
<b>DIGITAL CONTROL - LOGIC LEVELS AND TIMING CHARACTERISTICS</b>						
$V_{SPI}$	SPI supply voltage range	SPI_VIN		1.7	3.6	V
$V_{OL}$	Output low-level	RESETZ, CMP_OUT, CLK_OUT. $I_O = 0.3\text{ mA}$ sink current		0	0.3	V
		SPI_DOUT. $I_O = 5\text{ mA}$ sink current		0	$0.3 \times V_{SPI}$	
		INTZ. $I_O = 1.5\text{ mA}$ sink current		0	$0.3 \times V_{SPI}$	
$V_{OH}$	Output high-level	RESETZ, CMP_OUT, CLK_OUT. $I_O = 0.3\text{ mA}$ source current		1.3	2.5	V
		SPI_DOUT. $I_O = 5\text{ mA}$ source current		$0.7 \times V_{SPI}$	$V_{SPI}$	
$V_{IL}$	Input low-level	PROJ_ON, LED_SEL0, LED_SEL1		0	0.4	V
		SPI_CSZ, SPI_CLK, SPI_DIN		0	$0.3 \times V_{SPI}$	
$V_{IH}$	Input high-level	PROJ_ON, LED_SEL0, LED_SEL1		1.2		V
		SPI_CSZ, SPI_CLK, SPI_DIN		$0.7 \times V_{SPI}$	$V_{SPI}$	
$I_{BIAS}$	Input bias current	$V_{IO} = 3.3\text{ V}$ , any digital input pin			0.1	$\mu\text{A}$
SPI_CLK	SPI clock frequency <sup>(6)</sup>	Normal SPI mode, DIG_SPI_FAST_SEL = 0, $f_{OSC} = 9\text{ MHz}$		0	36	MHz
		Fast SPI mode, DIG_SPI_FAST_SEL = 1, $V_{SPI} > 2.3\text{ V}$ , $f_{OSC} = 9\text{ MHz}$		20	40	
$t_{DEGLITCH}$	Deglintch time	LED_SEL0, LED_SEL1 <sup>(3)</sup> .			300	ns
<b>INTERNAL OSCILLATOR</b>						
$f_{OSC}$	Oscillator frequency		9		MHz	
	Frequency accuracy	$T_A = 0\text{ to }70^\circ\text{C}$		-5%	5%	

(6) Maximum depends linearly on oscillator frequency  $f_{OSC}$ .

## Electrical Characteristics (continued)

over operating free-air temperature range.  $V_{IN} = 12\text{ V}$ ,  $T_A = 0\text{ to }+70^\circ\text{C}$ , typical values are at  $T_A = 25^\circ\text{C}$ , configuration according to [Typical Applications](#) ( $V_{IN} = 12\text{ V}$ ,  $I_{OUT} = 6\text{ A}$ , LED, internal FETs) (unless otherwise noted).

PARAMETER		TEST CONDITIONS	MIN	TYP	MAX	UNIT
<b>THERMAL SHUTDOWN</b>						
$T_{WARN}$	Thermal warning (HOT threshold)			120		°C
	Hysteresis			10		
$T_{SHTDWN}$	Thermal shutdown (TSD threshold)			150		°C
	Hysteresis			15		

The timing parameters ([SPI Timing Parameters](#)) and the SPI timing diagram ([Figure 1](#)) are given.

### 6.6 SPI Timing Parameters

$SPI\_VIN = 3.6\text{ V} \pm 5\%$ ,  $T_A = 0\text{ to }70^\circ\text{C}$ ,  $C_L = 10\text{ pF}$  (unless otherwise noted).

PARAMETER		MIN	MAX	UNIT
$f_{CLK}$	Serial clock frequency	0	40	MHz
$t_{CLKL}$	Pulse width low, SPI_CLK, 50% level	10		ns
$t_{CLKH}$	Pulse width high, SPI_CLK, 50% level	10		ns
$t_t$	Transition time, 20% to 80% level, all signals	0.2	4	ns
$t_{CSCR}$	SPI_SS_Z falling to SPI_CLK rising, 50% level	8		ns
$t_{CFCS}$	SPI_CLK falling to SPI_CSZ rising, 50% level		1	ns
$t_{CDS}$	SPI_MOSI data setup time, 50% level	7		ns
$t_{CDH}$	SPI_MOSI data hold time, 50% level	6		ns
$t_{IS}$	SPI_MISO data setup time, 50% level	10		ns
$t_{IH}$	SPI_MISO data hold time, 50% level	0		ns
$t_{CFDO}$	SPI_CLK falling to SPI_MISO data valid, 50% level		13	ns
$t_{CSZ}$	SPI_CSZ rising to SPI_MISO HiZ		6	ns

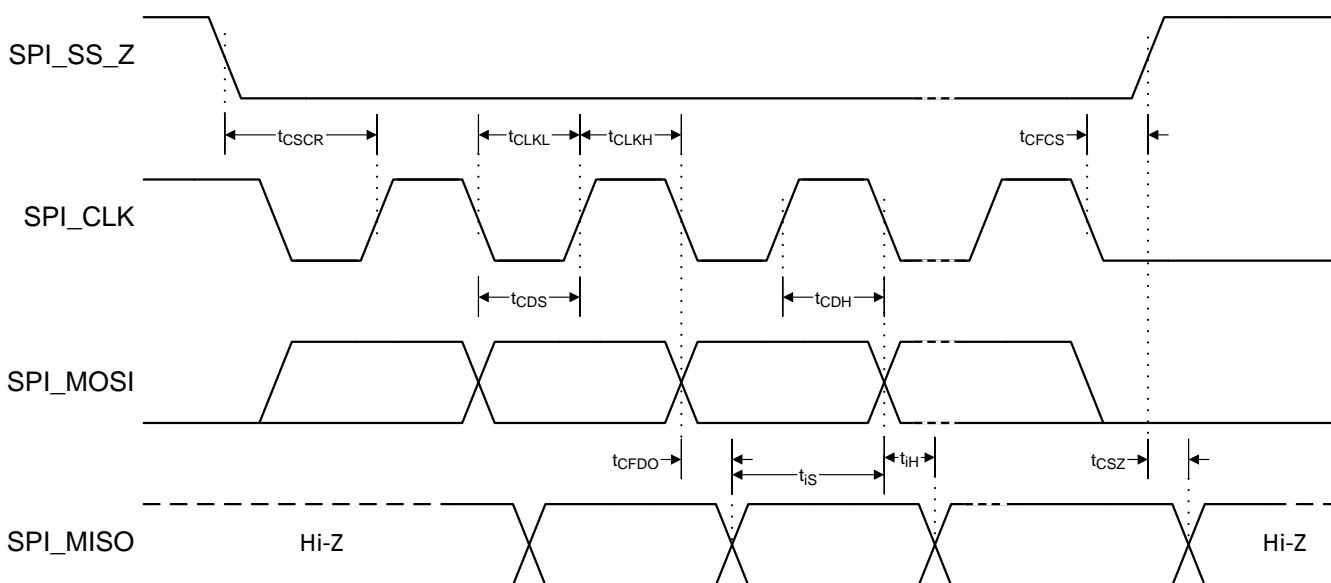

**Figure 1. SPI Timing Diagram**

## 7 Detailed Description

### 7.1 Overview

The DLPA3000 is a highly integrated power management IC optimized for DLP Pico Projector systems. It is targeting accessory applications up to several hundreds of lumen and is designed to support a wide variety of high-current LEDs. The Projector system supports the TRP type of digital mirror device (DMD). [Functional Block Diagram](#) shows a typical DLP Pico Projector implementation using the DLPA3000.

Part of the projector is the projector module which is an optimized combination of components consisting of for instance DLPA3000, LEDs, DMD, DLPC chip, memory and optional sensors/fans. The front-end chip controls the projector module. More information about the system and projector module configuration can be found in a separate application note.

Within the DLPA3000 several blocks can be distinguished. The blocks are listed below and subsequently discussed in detail:

1. Supply and monitoring: Creates internal supply and reference voltages and has functions such as thermal protection and low battery warning.
2. Illumination: Block to control the light. Contains drivers, strobe decoder for the LEDs and power conversion
3. DMD: Generates voltages and their specific timing for the DMD. Contains regulators and DMD/DLPC buck converters.
4. Buck converters: General purpose buck converters
5. Auxiliary LDOs: Fixed voltage LDOs for customer usage.
6. Measurement system: Analog front end to measure internal and external signals
7. Digital control: SPI, digital control

### 7.2 Functional Block Diagram

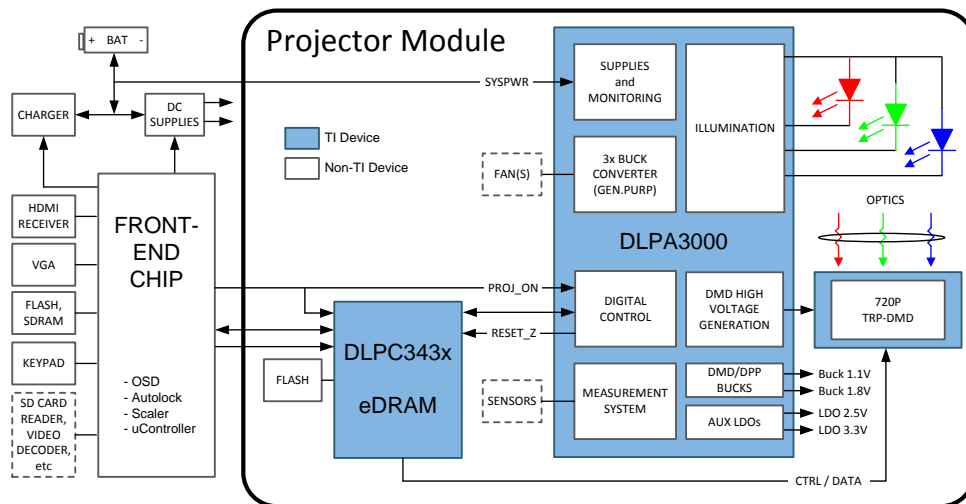

### 7.3 Feature Description

#### 7.3.1 Supply and Monitoring

This block takes care of creating several internal supply voltages and monitors correct behavior of the device.

## Feature Description (continued)

### 7.3.1.1 Supply

SYSPWR is the main supply of the DLPA3000. It can range from 6V to 20V, where the typical is 12 V. At power-up, several (internal) power supplies are started one after the other in order to make the system work correctly (Figure 2). A sequential startup ensures that all the different blocks start in a certain order and prevent excessive startup currents. The main control to start the DLPA3000 is the control pin "PROJ\_ON". Once set high the *basic* analog circuitry is started that is needed to operate the digital and SPI interface. This circuitry is supplied by two LDO regulators that generate 2.5 V (SUP\_2P5V) and 5 V (SUP\_5P0V). These regulator voltages are for internal use only and should not be loaded by an external application. The output capacitors of those LDOs should be 2.2  $\mu$ F for the 2.5 V LDO and 4.7  $\mu$ F for the 5 V LDO, pin 91 and 92, respectively. Once these are up the digital core is started, and the DLPA3000 Digital State Machine (DSM) takes over.

Subsequently, the 5.5 V LDOs for various blocks are started: PWR\_5V5V, DRST\_5P5V and ILLUM\_5P5V. Next, the buck converters and DMD LDOs are started (PWR\_1 to PWR\_4). The DLPA3000 is now awake and ready to be controlled by the DLPC (indicated by RESET\_Z going high).

Lastly, the general purpose buck converters (PWR\_5 to 7) can be started (if used) as well as the regulator that supplies the DMD. The DMD regulator generates the timing critical VOFFSET, VBIAS and VRESET supplies.

Feature Description (continued)

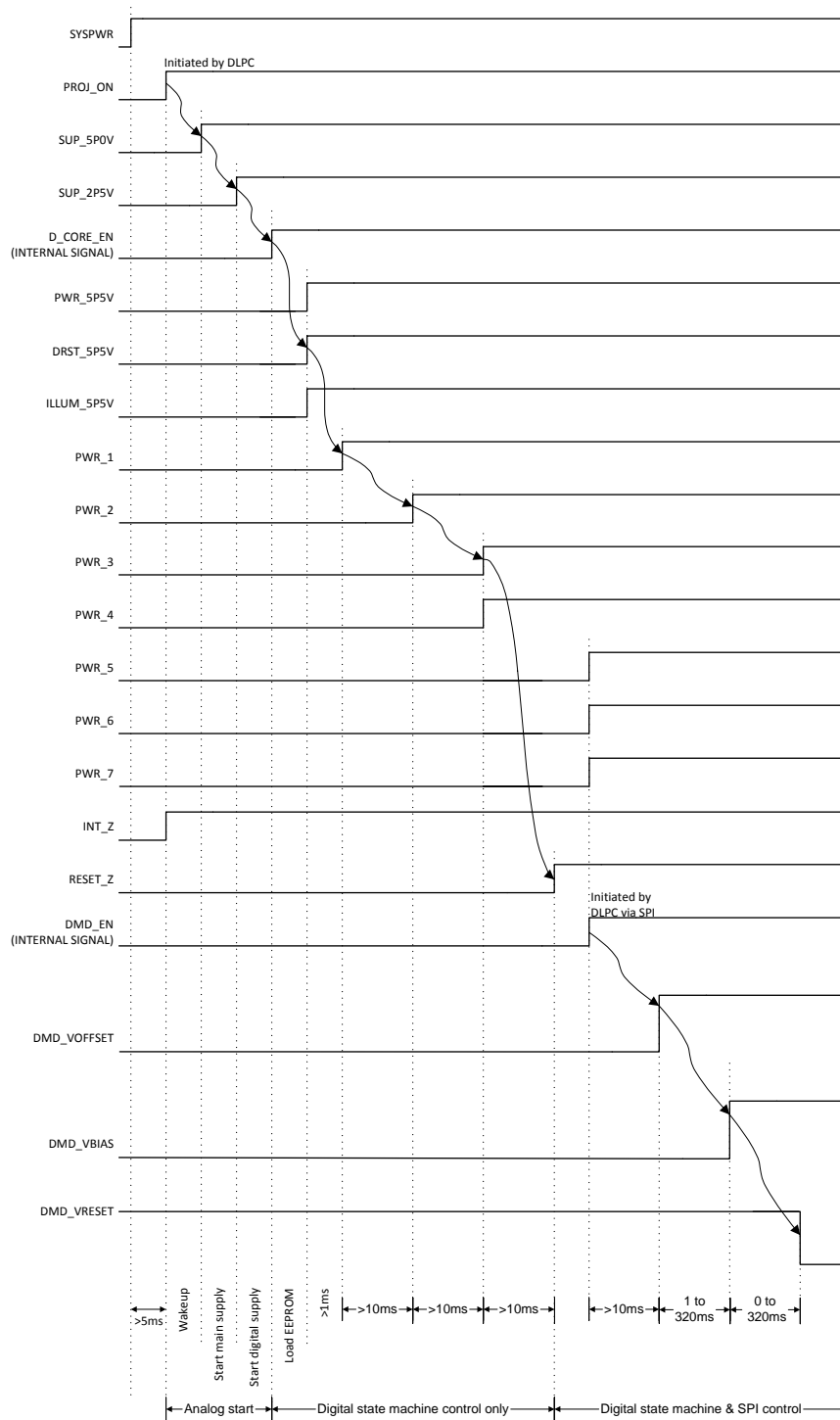

Figure 2. Powerup Timing <sup>(1)</sup>

(1) Arrows indicate sequence of events automatically controlled by digital state machine. Other events are initiated under SPI control.

## Feature Description (continued)

### 7.3.1.2 Monitoring

Several possible faults are monitored by the DLPA3000. If a fault has occurred and what kind of fault it is can be read in register 0x0C. Subsequently, an interrupt can be generated if such a fault occurs. The fault conditions for which an interrupt is generated can be configured individually in register 0x0D.

#### 7.3.1.2.1 Block Faults

Fault conditions for several supplies can be observed such as the low voltage supplies (SUPPLY\_FAULT). ILLUM\_FAULT monitors correct supply and voltage levels in the illumination block and DMD\_FAULT monitors a correct functioning DMD block. The PROJ\_ON\_INT bit indicates if PROJ\_ON was asserted.

#### 7.3.1.2.2 Low Battery and UVLO

Monitoring is also done on the battery voltage (input supply) by the low battery warning (BAT\_LOW\_WARN) and battery low shutdown (BAT\_LOW\_SHUT) (see Figure 3). They warn for a low  $V_{IN}$  supply voltage or automatically shutdown the DLPA3000 when the  $V_{IN}$  supply drops below a predefined level, respectively. The threshold levels for these fault conditions can be set from 3.9 V to 18.4 V by writing to registers 0x10<4:0> (LOWBATT) and 0x11<4:0> (BAT\_LOW\_SHUT\_UVLO). These threshold levels have hysteresis. This hysteresis depends on the selected threshold voltage and is depicted in Figure 4. It is recommended to set the low battery voltage higher than the under voltage lock out such that a warning is generated before the device goes into shutdown.

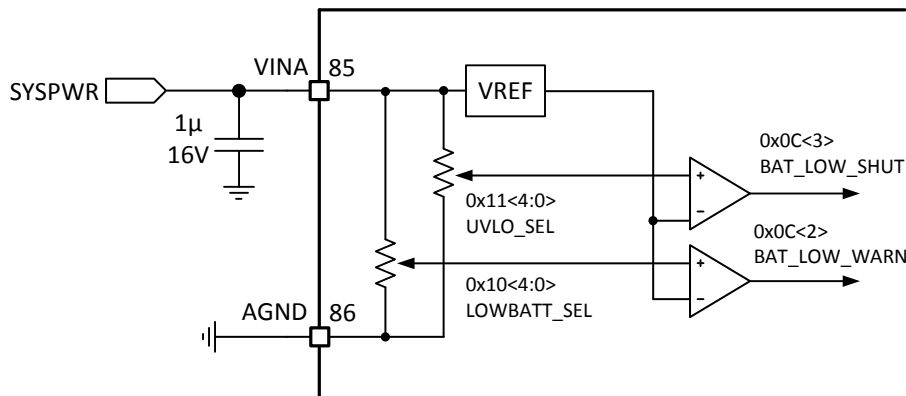

Figure 3. Battery Voltage Monitoring

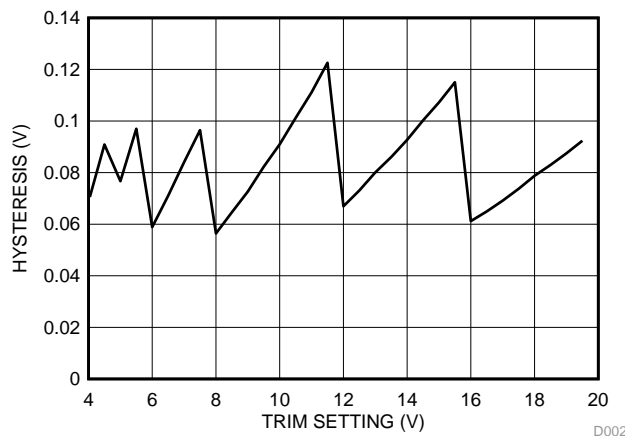

Figure 4. Hysteresis on  $V_{LOW\_BAT}$  and  $V_{UVLO}$

## Feature Description (continued)

### 7.3.1.2.3 Auto LED Turn Off Functionality

The PAD devices can be supplied from either a battery pack or an adapter. The PAD devices use several warning and detection levels, as indicated in the previous paragraphs, to prevent system damage in case the supply voltage becomes too low or even interrupted.

Interruption of the supply voltage occurs when, for instance, the adapter is switched to another mains outlet. In case a battery pack is installed, the system power control should switch at that moment to the battery pack. A change of supply voltage from, for instance, 20 V to 8 V can occur, and thus the OVP level (which is ratio-metric; see [Ratio Metric Overvoltage Protection](#)) could become lower than  $V_{LED}$ . An OVP fault will be triggered and the system will switch off.

The `Auto_LED_Turn_Off` functionality can be used to prevent the system from turning off in these circumstances. This function disables the LEDs when the supply voltage drops below `LED_AUTO_OFF_LEVEL` (reg 0x18h). It is advisable to have this level the same as the `BAT_LOW_WARN` level. When the `Auto_LED_Turn_Off` functionality is enabled (reg 0x01h), once a supply voltage drop is detected to below `LED_AUTO_OFF_LEVEL`, the LEDs will be switched off and the system should start sending lower current levels to have a lower  $V_{LED}$ . After start using lower currents, the LEDs can be switched on again by disabling `AUTO_LED_TURN_OFF` function. As a result, the system can continue working at the lower supply voltage using a lower intensity. The system has to monitor the `BAT_LOW_WARN` status, and once the mains adapter is plugged in again (seen by `BAT_LOW_WARN` being low), the `Auto_LED_Turn_Off` functionality can be enabled again. Now the LED currents can be restored to their original levels from before the supply voltage drop.

### 7.3.1.2.4 Thermal Protection

The chip temperature is constantly monitored to prevent overheating of the device. There are two levels of fault condition (register 0x0C). The first is to warn for overheating (`TS_WARN`). This is an indication that the chip temperature raises to a critical temperature. The next level of warning is `TS_SHUT`. This occurs at a higher temperature than `TS_WARN` and will shutdown the chip to prevent permanent damage. Both temperature faults have hysteresis on their levels to prevent rapid switching around the temperature threshold.

## 7.3.2 Illumination

The illumination function includes all blocks needed to generate light for the DLP system. In order to set accurately the current through the LEDs a control loop is used ([Figure 5](#)). The intended LED current is set via `IDAC[9:0]`. The Illumination driver controls the LED anode voltage  $V_{LED}$  and as a result a current will flow through one of the LEDs. The LED current is measured via the voltage across sense resistor  $R_{LIM}$ . Based on the difference between the actual and intended current, the loop controls the output of the buck converter ( $V_{LED}$ ) higher or lower. Which LED conducts the current is controlled by switches P, Q, and R. The *Openloop feedback circuitry* ensures that the control loop can be closed for cases when there is no path via the LED, for instance when  $I_{LED} = 0$ .

Feature Description (continued)

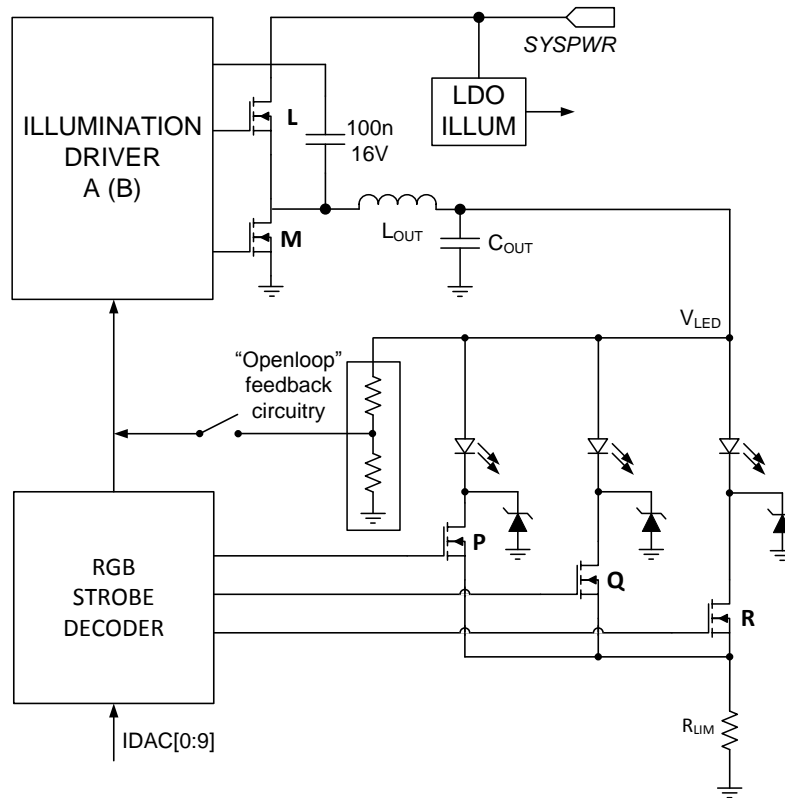

Figure 5. Illumination Control Loop

Within the illumination block, the following blocks can be distinguished:

- Programmable gain block
- LDO illum: analog supply voltage for internal illumination blocks.
- Illumination driver A: primary driver using internal FETs.
- Illumination driver B: secondary driver – for future purpose; will not be discussed.
- RGB stobe decoder: controls the on-off rhythm of the LEDs and measures the LED current.

7.3.2.1 Programmable Gain Block

The current through the LEDs is determined by a digital number stored in the respective IDAC registers 0x03h to 0x08h. These registers determine the LED current which is measured through the sense resistor  $R_{LIM}$ . The voltage across  $R_{LIM}$  is compared with the current setting from the IDAC registers and the loop regulates the current to its set value.

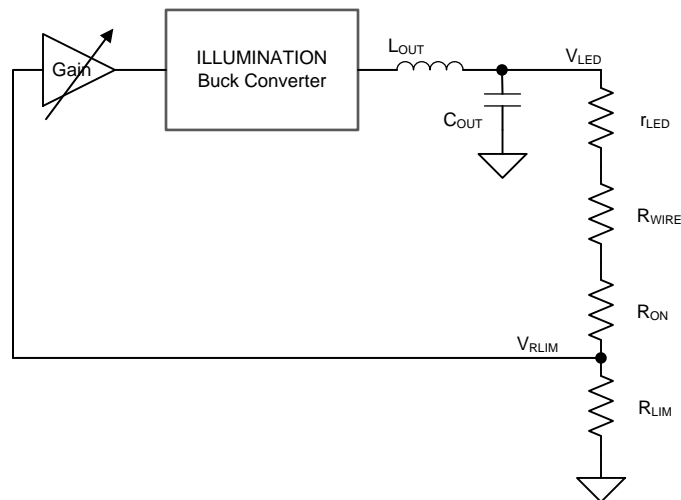
**Feature Description (continued)**

**Figure 6. Programmable Gain Block in the Illumination Control Loop**

When current is flowing through an LED, a forward voltage is built up over the LED. The LED also represents a (low) differential resistance, which is part of the load circuit for  $V_{LED}$ . Together with the wire resistance ( $R_{WIRE}$ ) and the  $R_{ON}$  resistance of the FET switch, a voltage divider is created with  $R_{LIM}$  that is a factor in the loop gain of the ILED control. Under normal conditions, the loop is able to produce a well-regulated LED current of up to 6 A.

Since this voltage divider is part of the control loop, care must be taken while designing the system.

When, for instance, two LEDs in series are connected, or when a relatively high wiring resistance is present in the loop, the loop gain will reduce due to the extra attenuation caused by the increased series resistances of  $r_{LED} + R_{WIRE} + R_{ON}$ . As a result, the loop response time lowers. To compensate for this increased attenuation, the loop gain can be increased by selecting a higher gain for the programmable gain block. The gain increase can be set through register 0x25h [3:0].

Under normal circumstances, the default gain setting (00h) is sufficient. In case of a series, connection of two LEDs setting 01h or 02h might suffice.

As discussed before, wiring resistance also impacts the control-loop performance. It is advisable to prevent unnecessary large-wire length in the loop. Keeping wiring resistance as low as possible is good for efficiency reasons. In case wiring resistance still impacts the response time of the loop, an appropriate setting of the gain block can be selected. The same goes for connector resistance and PCB tracks. Keep in mind that basically every mΩ counts. Following these precautions will help get a proper functioning of the  $I_{LED}$  current loop.

### 7.3.2.2 LDO Illum

This regulator is dedicated to the illumination block and provides an analog supply of 5.5 V to the internal circuitry. It is recommended to use 1-μF capacitors on both the input and output of the LDO.

### 7.3.2.3 Illumination Driver A

The illumination driver of the DLPA3000 is a buck converter with two internal low-ohmic N-channel FETs (see [Figure 7](#)). The theory of operation of a buck converter is explained in *Understanding Buck Power Stages in Switchmode Power Supplies (SLVA057)*. For proper operation, selection of the external components is very important, especially the inductor  $L_{OUT}$  and the output capacitor  $C_{OUT}$ . For best efficiency and ripple performance, an inductor and capacitor should be chosen with low equivalent series resistance (ESR).

Feature Description (continued)

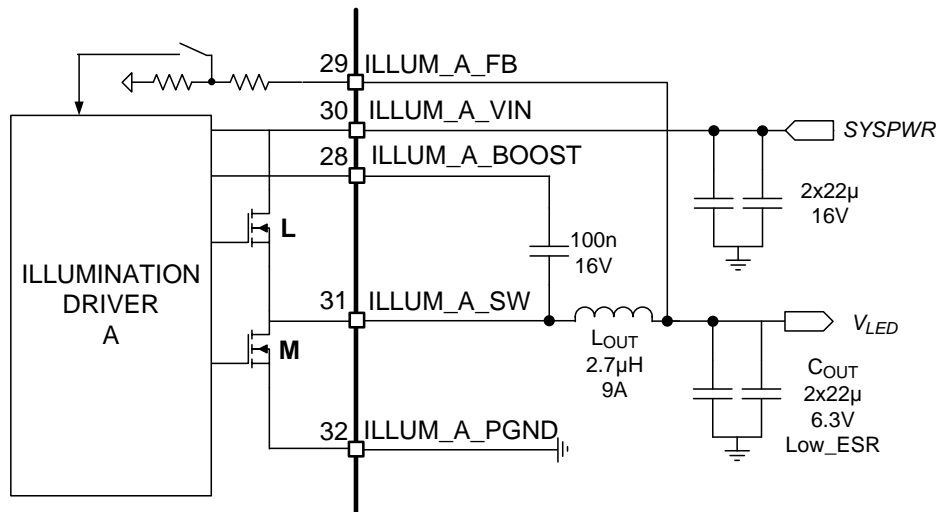

Figure 7. Typical Illumination Driver Configuration

Several factors determine the component selection of the buck converter, such as input voltage (SYSPWR), desired output voltage (V<sub>LED</sub>) and the allowed output current ripple. Configuration starts with selecting the inductor L<sub>OUT</sub>.

The value of the inductance of a buck power stage is selected such that the peak-to-peak ripple current flowing in the inductor stays within a certain range. Here, the target is set to have an inductor current ripple, k<sub>I\_RIPPLE</sub>, less than 0.3 (30%). The minimum inductor value can be calculated given the input and output voltage, output current, switching frequency of the buck converter (f<sub>SWITCH</sub>= 600 kHz) and inductor ripple of 0.3 (30%):

$$L_{OUT} = \frac{\frac{V_{OUT}}{V_{IN}} \cdot (V_{IN} - V_{OUT})}{k_{I\_RIPPLE} \cdot I_{OUT} \cdot f_{SWITCH}} \quad (1)$$

Example: V<sub>IN</sub>= 12 V, V<sub>OUT</sub>= 4.3 V, I<sub>OUT</sub>= 6 A results in an inductor value of L<sub>OUT</sub>= 2.7 µH

Once the inductor is selected, the output capacitor C<sub>OUT</sub> can be determined. The value is calculated using the fact that the frequency compensation of the illumination loop has been designed for an LC-tank resonance frequency of 15 kHz:

$$f_{RES} = \frac{1}{2 \cdot \pi \cdot \sqrt{L_{OUT} \cdot C_{OUT}}} = 15kHz \quad (2)$$

Example: C<sub>OUT</sub>= 41.7 µF given that L<sub>OUT</sub>= 2.7 µH. A practical value is 2 × 22 µF. Here a parallel connection of two capacitors is chosen to lower the ESR even further.

The selected inductor and capacitor determine the output voltage ripple. The resulting output voltage ripple V<sub>LED\_RIPPLE</sub> is a function of the inductor ripple k<sub>I\_RIPPLE</sub>, output current I<sub>OUT</sub>, switching frequency f<sub>SWITCH</sub> and the capacitor value C<sub>OUT</sub>:

$$V_{LED\_RIPPLE} = \frac{k_{I\_RIPPLE} \cdot I_{OUT}}{8 \cdot f_{SWITCH} \cdot C_{OUT}} \quad (3)$$

Example: k<sub>I\_RIPPLE</sub>= 0.3, I<sub>OUT</sub>= 6 A, f<sub>SWITCH</sub>= 600 kHz and C<sub>OUT</sub>= 44 µF results in an output voltage ripple of V<sub>LED\_RIPPLE</sub>= 8.5 mVpp

As can be seen, this is a relative small ripple.

It is strongly advised to keep the capacitance value low. The larger the capacitor value the more energy is stored. In case of a V<sub>LED</sub> going down, stored energy needs to be dissipated. This might result in a large discharge current. For a V<sub>LED</sub> step down from V<sub>1</sub> to V<sub>2</sub>, while the LED current was I<sub>1</sub>. The theoretical peak reverse current is:

**Feature Description (continued)**

$$I_{2,MAX} = \sqrt{\frac{C_{OUT}}{L_{OUT}} \times (V_1^2 - V_2^2) + I_1^2} \quad (4)$$

For the single-LED case, it is advised to keep  $C_{OUT}$  at maximum 44 $\mu$ F.

Two other components need to be selected in the buck converter. The value of the input-capacitor (pin ILLUM\_A\_VIN) should be equal to or greater than the selected output capacitance  $C_{OUT}$ , in this case >44  $\mu$ F. The capacitor between ILLUM\_A\_SWITCH and ILLUM\_A\_BOOST is a charge pump capacitor to drive the high side FET. The recommended value is 100 nF.

**7.3.2.4 RGB Strobe Decoder**

The DLPA3000 contains circuitry to sequentially control the three color-LEDs (red, green and blue). This circuitry consists of three NMOS switches, the actual strobe decoder, and the LED current control (Figure 8). The NMOS switches are connected to the cathode terminals of the external LED package and turn the currents through the LEDs on and off.

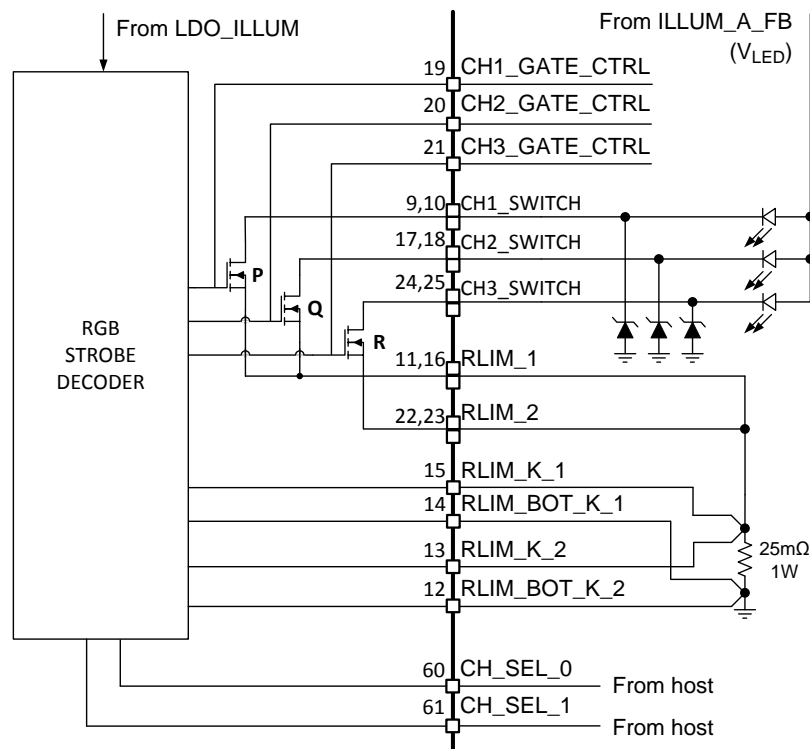

**Figure 8. Switch Connection for a Common-Anode LED assembly**

The NMOS FET's P, Q and R are controlled by the CH\_SEL\_0 and CH\_SEL\_1 pins. CH\_SEL[1:0] typically receive a rotating code switching from RED to GREEN to BLUE and then back to RED. The relation between CH\_SEL[0:1] and which switch is closed is indicated in Table 1.

Feature Description (continued)

Table 1. Switch Positions for Common Anode RGB LEDs

PINS CH_SEL[1:0]	SWITCH			IDAC REGISTER
	P	Q	R	
00	Open	Open	Open	N/A
01	Closed	Open	Open	0x03 and 0x04 SW1_IDAC[9:0]
10	Open	Closed	Open	0x05 and 0x06 SW2_IDAC[9:0]
11	Open	Open	Closed	0x07 and 0x08 SW3_IDAC[9:0]

Besides enabling one of the switches, CH\_SEL[1:0] also selects a 10-bit current setting for the control IDAC that is used as the set current for the LED. This set current together with the measured current through R<sub>LIM</sub> is used to control the illumination driver to the appropriate V<sub>LED</sub>. The current through the 3 LEDs can be set independently by registers 0x03 to 0x08 (Table 1).

Each current level can be set from off to 150mV/R<sub>LIM</sub> in 1023 steps:

$$\text{Led current(A)} = 0 \text{ for bit value} = 0$$

$$\text{Led current(A)} = \frac{\text{Bit value} + 1}{1024} \cdot \frac{150\text{mV}}{R_{LIM}} \text{ for bit value} = 1 \text{ to } 1023 \tag{5}$$

The maximum current for R<sub>LIM</sub>= 25 mΩ is thus 6 A.

7.3.2.4.1 Break Before Make (BBM)

The switching of the three LED NMOS switches (P, Q, and R) is controlled such that a switch is returned to the OPEN position first before the subsequent switch is set to the CLOSED position (BBM). (See Figure 9.) The dead time between opening and closing switches is controlled through the BBM register (0x0E). Switches that already are in the CLOSED position and are to remain in the CLOSED state are not opened during the BBM delay time.

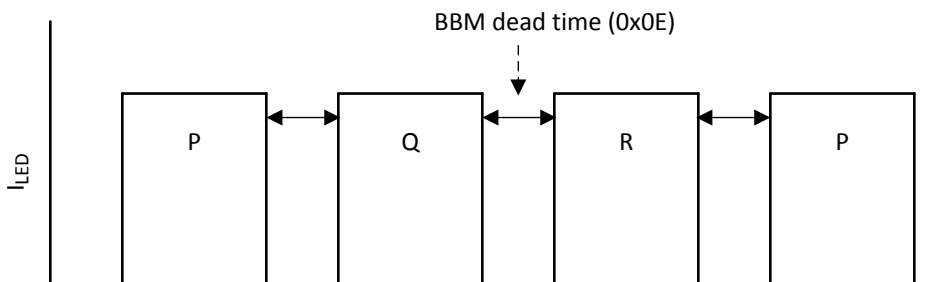

Figure 9. BBM Timing

7.3.2.4.2 Openloop Voltage

Several situations exist in which the control loop for the buck converter via the LED is not present. In order to prevent the output voltage of the buck converter to run-away, the loop is closed by means of an internal resistive divider (see Figure 5 - Openloop feedback circuitry). Situations in which the openloop voltage control is active:

- During the BBM period. Transitions from one LED to another implies that during the BBM time all LEDs are off.
- Current setting for all three LEDs is 0.

It is advised to set the openloop voltage to about the lowest LED forward voltage. The openloop voltage can be set between 3 V and 18 V in steps of 1 V through register 0x18.

### 7.3.2.4.3 Transient Current Limit

Typically the forward voltages of the GREEN and BLUE diodes are close to each other (about 3 V to 5 V) however the forward voltage of the red diode is significantly lower (2 V to 4 V). This can lead to a current spike in the RED diode when the strobe controller switches from green or blue to red. This happens because  $V_{LED}$  is initially at a higher voltage than required to drive the red diode. DLPA3000 provides transient current limiting for each switch to limit the current in the LEDs during the transition. The transient current limit value is controlled through register 0x02 (ILLUM\_ILIM). In a typical application it is required only for the RED diode. The value for ILLUM\_ILIM should be set at least 20% higher than the DC regulation current. Register 0x02 (ILLUM\_SW\_ILIM\_EN) contains three bits to select which switch employs the transient current limiting feature. The effect of the transient current limit on the LED current is shown in Figure 10.

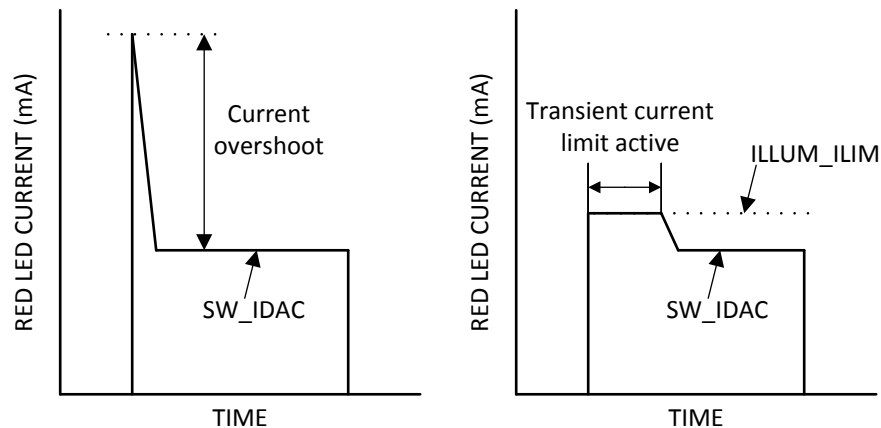

**Figure 10. LED Current Without (Left) and With (Right) Transient Current Limit**

### 7.3.2.5 Illumination Monitoring

The illumination block is continuously monitored for system failures to prevent damage to the DLPA3000 and LEDs. Several possible failures are monitored, such as a broken control loop and a too high or too low output voltage  $V_{LED}$ . The overall illumination fault bit is in register 0x0C (ILLUM\_FAULT). If any of the below failures occur, the ILLUM\_FAULT bit may be set high:

- ILLUM\_BC1\_PG\_FAULT
- ILLUM\_BC1\_OV\_FAULT

Where PG is power good and OV is overvoltage.

#### 7.3.2.5.1 Power Good

Both the Illumination driver and the Illumination LDO have a power good indication. The power good for the driver indicates if the output voltage ( $V_{LED}$ ) is within a defined window indicating that the LED current has reached the set point. If, for some reason, the LED current cannot be controlled to the intended value, this fault occurs. Subsequently, bit ILLUM\_BC1\_PG\_FAULT in register 0x27 is set high. The illumination LDO output voltage is also monitored. When the power good of the LDO is asserted, it implies that the LDO voltage is below a pre-defined minimum of 80% (rising) or 60% (falling) edge. The power good indication for the LDO is in register 0x27 (V5V5\_LDO\_ILLUM\_PG\_FAULT).

#### 7.3.2.5.2 Ratio Metric Overvoltage Protection

The DLPA3000 illumination driver LED outputs are protected against open circuit use. In case no LED is connected and the PAD device is instructed to set the LED current to a specific level, the LED voltage (ILLUM\_A\_FB) will quickly rise and potentially rail to  $V_{IN}$ . This should be prevented. The OVP protection circuit triggers once  $V_{LED}$  crosses a predefined level. As a result the DLPA3000 will be switched off.

The same protection circuit is triggered in case the supply voltage ( $V_{INA}$ ) will become too low to have the DLPA3000 work properly given the  $V_{LED}$  level. This protection circuit is constructed around a comparator that will sense both the LED voltage and the  $V_{INA}$  supply voltage. The fraction of the  $V_{INA}$  is connected to the minus input of the comparator while the fraction of the  $V_{LED}$  voltage is connected to the plus input. Triggering occurs when the plus input rises above the minus input and an OVP fault is set. The fraction of the  $V_{INA}$  must be set between 1 V and 4 V to ensure proper operation of the comparator.

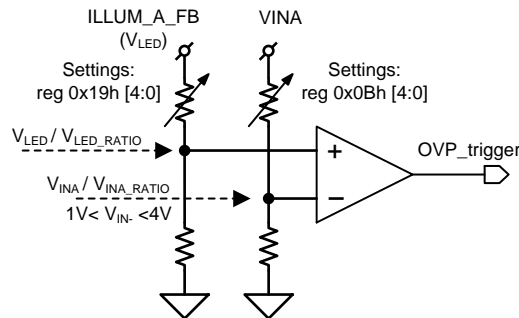

Figure 11. Ratio Metric OVP

The fraction of the ILLUM\_A\_FB voltage is set by the register 0x19h bits [4:0], while the setting of the fraction of the  $V_{INA}$  voltage is done by register 0x0Bh bits [4:0]. In general an OVP fault is set when

$$V_{LED}/V_{LED\_RATIO} \geq V_{INA}/V_{INA\_RATIO}$$

thus when:

$$V_{LED} \geq V_{INA} \times V_{LED\_RATIO}/V_{INA\_RATIO}$$

Clearly, the OVP level is ratio-metric, i.e. can be set to a fixed fraction of  $V_{INA}$ .

For example:  $V_{LED}$  should stay below 85% of  $V_{INA}$ . The settings for the respective registers are:

- reg 0x19h [4:0] = 01h (4.98)
- reg 0x0Bh [4:0] = 07h (5.85)

The result is as follows: OVP triggers if  $V_{LED} \geq V_{INA} \times 4.98/5.85 = 0.85 V_{INA}$ .

Additionally, for  $V_{IN\_RATIO} = 5.85$ , the  $V_{IN}$  input voltage for the comparator is between 1 V and 3.4 V for a supply voltage between 6 V and 20 V.

### 7.3.2.6 Load Current and Supply Voltage

The DLPA3000 is designed to be able to deliver a current up to 6 Amps to a LED light source. This maximum current depends on the  $V_{LED}$  that is built up over the LED including all series resistances like  $R_{ON}$ ,  $R_{WIRE}$  and  $R_{LIM}$  (see Figure 6). The Illum Buck Converter needs some headroom to work properly. This paragraph shows two typical situations for a fixed LED voltage and the accompanying supply voltage range for which a current of 4A or 6A can be delivered. Figure 12 shows the relation between the LED current and the supply voltage for a fixed LED voltage of 5 V, while Figure 13 shows this relation for a LED voltage of 6.3 V. While varying the Supply Voltage the curve shows a constant load current for a given LED voltage above the point where the control loop can maintain a constant current, but the load current drops below the point where the loop is no longer able to keep the current on its value set by the register. This knee-point shifts to higher supply voltage with rising temperature.

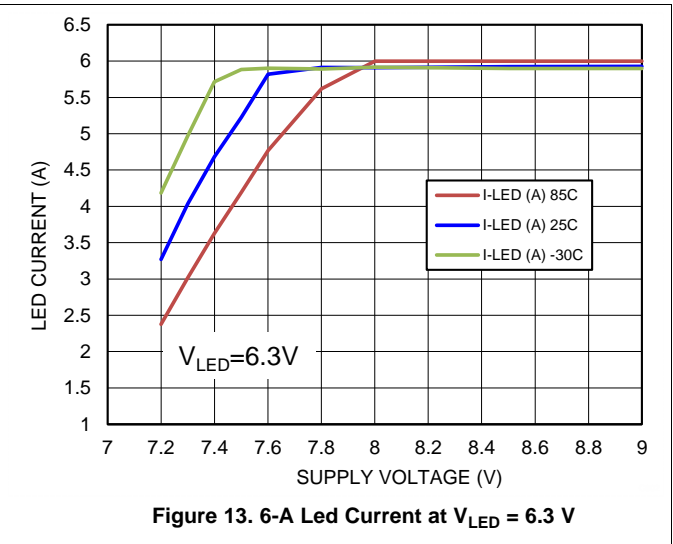
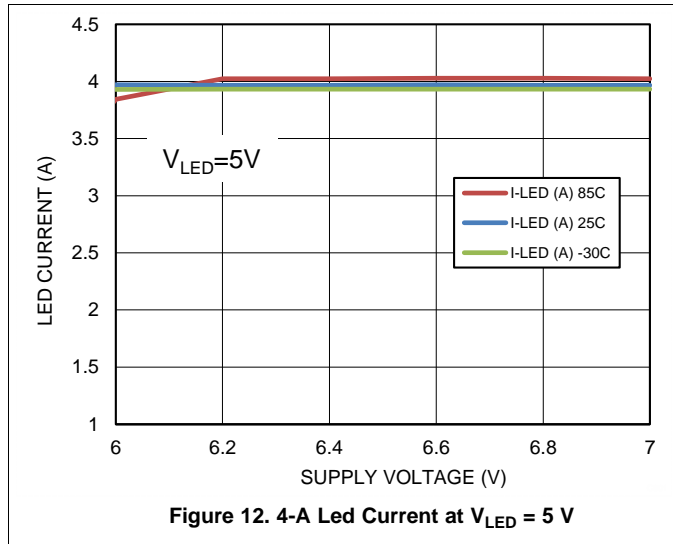

### 7.3.2.7 Illumination Driver Plus Power FETS Efficiency

Figure 14 is an overview of the efficiency of the illumination driver plus power FETS for an input voltage of 12 V. The efficiency is shown for several output voltage levels ( $V_{LED}$ ) where the load current is swept.

Figure 15 displays the efficiency versus input voltage ( $V_{ILLUM\_A\_VIN}$ ) at various output voltage levels ( $V_{LED}$ ).

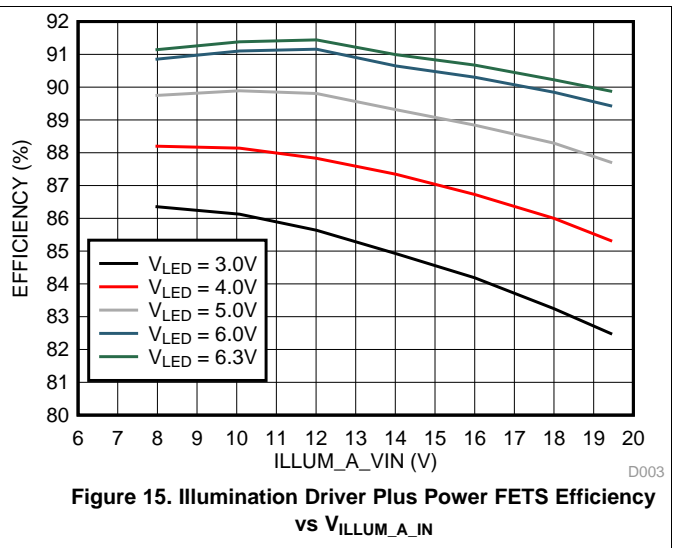
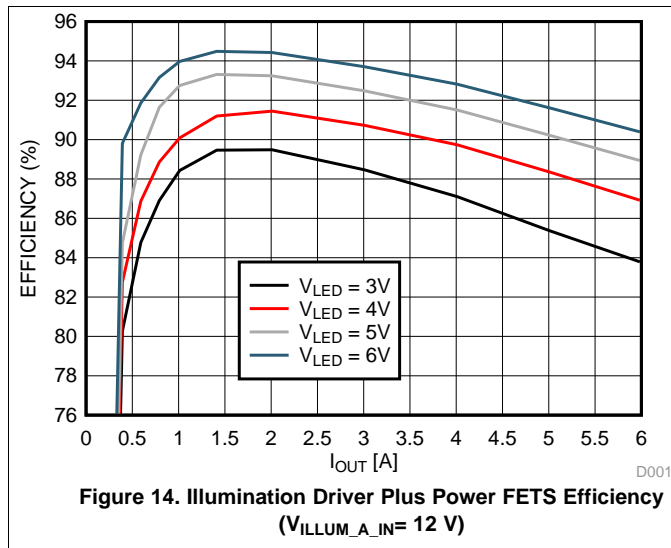

### 7.3.3 DMD Supplies

This block contains all the supplies needed for the DMD and DLPC (see [Figure 16](#)). The block comprises:

- LDO\_DMD: for internal supply
- DMD\_HV: regulator generates high voltage supplies
- Two buck converters: for DLPC/DMD voltages

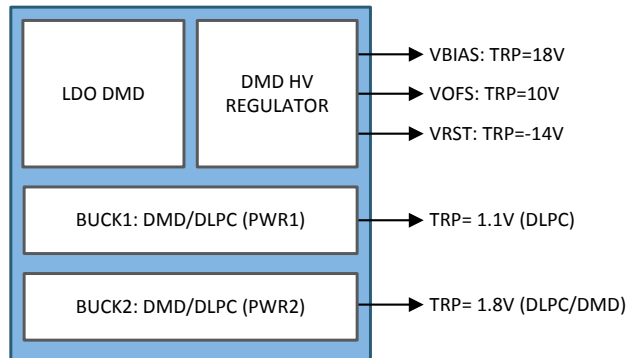

**Figure 16. DMD Supplies Blocks**

The DMD supplies block is designed to work with the TRP-type DMD and the related DLPC. The TRP-type DMD has its own set of supply voltage requirements. Besides the three high voltages, two supplies are needed for the DMD and the related DLPC (DLPC343x-family for instance). These supplies are made by two buck converters.

The EEPROM of the DLPA3000 is factory programmed for a certain configuration, such as which buck converters are used. Which configuration is programmed in EEPROM can be read in the capability register 0x26. It concerns the following bits:

- DMD\_BUCK1\_USE
- DMD\_BUCK2\_USE

A description of the function of these capability bits can be found in the register map, register 0x26.

#### 7.3.3.1 LDO DMD

This regulator is dedicated to the DMD supplies block and provides an analog supply voltage of 5.5 V to the internal circuitry. It is recommended to use a 1- $\mu$ F/16-V capacitor on the input and a 10- $\mu$ F/6.3-V capacitor on the output of the LDO assuming a battery voltage of 12 V.

#### 7.3.3.2 DMD HV Regulator

The DMD HV regulator generates three high voltage supplies: DMD\_VRESET, DMD\_VBIAS and DMD\_VOFFSET (see [Figure 17](#)). The DMD HV regulator uses a switching regulator (switch A-D), where the inductor is time shared between all three supplies. The inductor is charged up to a certain current value (current limit) and then discharged into one of the three supplies. If not all supplies need charging, the time available will be equally shared between those that do need charging. The recommended value for the capacitors is 1  $\mu$ F for  $V_{RST}$  and  $V_{OFS}$ , and 470 nF for  $V_{BIAS}$ . The inductor value is 10  $\mu$ H.

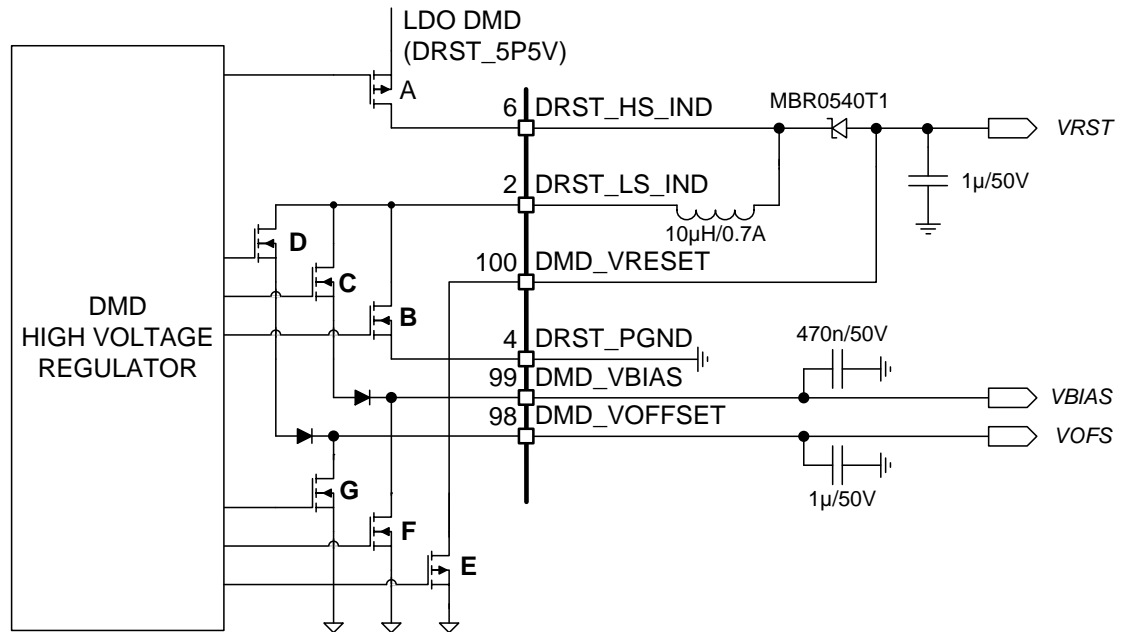

Figure 17. DMD High Voltage Regulator

### 7.3.3.2.1 Power-Up and Power-Down Timing

The power-up and power-down sequence is important to ensure a correct operation of the DLPA3000 and to prevent damage to the DMD. The DLPA3000 controls the correct sequencing of the DMD\_VRESET, DMD\_VBIAS and DMD\_VOFFSET to ensure a reliable operation of the DMD.

The general startup sequence of the supplies was described previously in [Supply and Monitoring](#). The power-up sequence of the high-voltage DMD lines is especially important to prevent damaging the DMD. Damage could include, for example, that DMD mirrors get stuck or collide. A too-large delta voltage between DMD\_VBIAS and DMD\_VOFFSET could cause the damage and should therefore be prevented.

After PROJ\_ON is pulled high, the DMD buck converters and LDOs are powered (PWR1-4) the DMD high voltage lines (HV) are sequentially enabled. First, DMD\_VOFFSET is enabled. After a delay, VOFS\_STATE\_DURATION (register 0x10) DMD\_VBIAS is enabled. Finally, after another delay, VBIAS\_STATE\_DURATION (register 0x11) DMD\_VRESET is enabled. The DLPA3000 is now fully powered and ready for starting projection.

For power down, there are two sequences: normal power down ([Figure 18](#)) and a fault fast powerdown used in case a fault occurs ([Figure 19](#)).

In normal power-down mode, the power down is initiated after pulling PROJ\_ON pin low. 25 ms after PROJ\_ON is pulled low, DMD\_VBIAS and DMD\_VRESET will stop regulating. 10 ms later, DMD\_VOFFSET will stop regulating. When DMD\_VOFFSET stops regulating, RESET\_Z is pulled low. 1 ms after the DMD\_VOFFSET stops regulating, all three voltages are discharged. Finally, all other supplies are turned off. INT\_Z remains high during the power-down sequence since no fault occurred. During power down, it is guaranteed that the HV levels do not violate the DMD specifications on these three lines. For this, it is important to select the capacitors such that  $C_{V\text{OFFSET}}$  is equal to  $C_{V\text{RESET}}$  and  $C_{V\text{BIAS}}$  is  $\leq C_{V\text{OFFSET}}$ .

The fast power-down mode ([Figure 19](#)) is started in case a fault occurs (INT\_Z will be pulled low), for instance due to overheating. The fast power-down mode can be enabled or disabled through register 0x01, FAST\_SHUTDOWN\_EN. The mode is enabled by default. After the fault occurs, regulation of DMD\_VBIAS and DMD\_VRESET is stopped. The time (delay) between fault and stop of regulation can be controlled through register 0x0F (VBIAS/VRST\_DELAY). The delay can be selected between 4  $\mu\text{s}$  and  $\approx 1.1$  ms, where the default is  $\approx 540$   $\mu\text{s}$ . A defined delay-time after the regulation stopped, all three high voltages lines are discharged and RESET\_Z is pulled low. The delay can be controlled through register 0x0F (VOFS/VRESETZ\_DELAY). Delay can be selected between 4  $\mu\text{s}$  and  $\approx 1.1$ ms. The default is  $\approx 4$   $\mu\text{s}$ . Finally, the internal DMD\_EN signal is pulled low.

**DLPA3000**

DLPS052 – OCTOBER 2015

[www.ti.com](http://www.ti.com)

Now the DLPA3000 is in a standby state. It remains in standby state until the fault resolves. In case the fault resolves, a restart is initiated. It starts then by powering up PWR\_3 and follows the regular power up as depicted in [Figure 19](#). Again, for proper discharge timing and levels, the capacitors should be selected such that  $C_{V\text{OFFSET}}$  is equal to  $C_{V\text{RESET}}$  and  $C_{V\text{BIAS}} \leq C_{V\text{OFFSET}}$ .

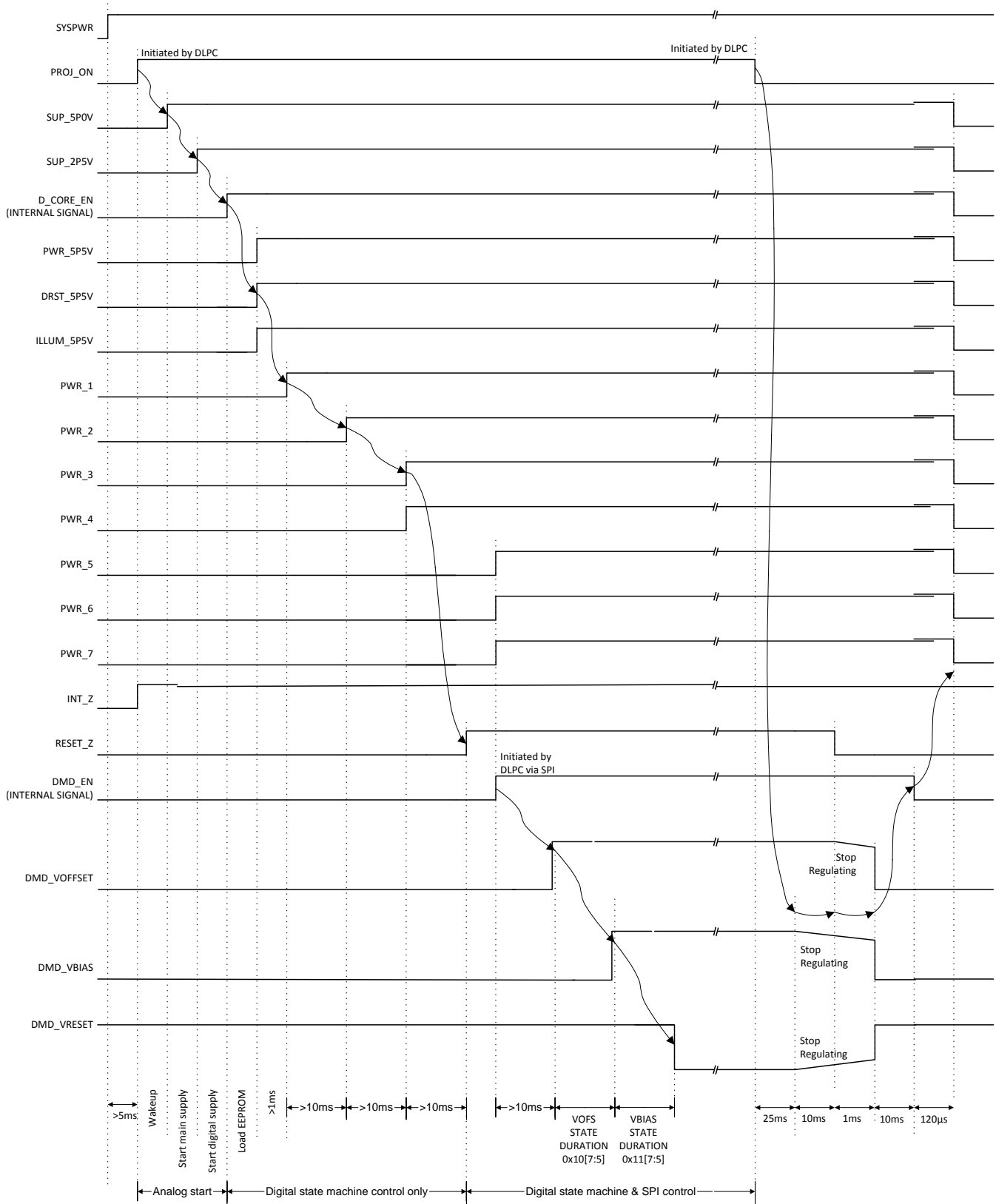

(1) Arrows indicate sequence of events automatically controlled by digital state machine. Other events are initiated under SPI control.

Figure 18. Power Sequence Normal Shutdown Mode

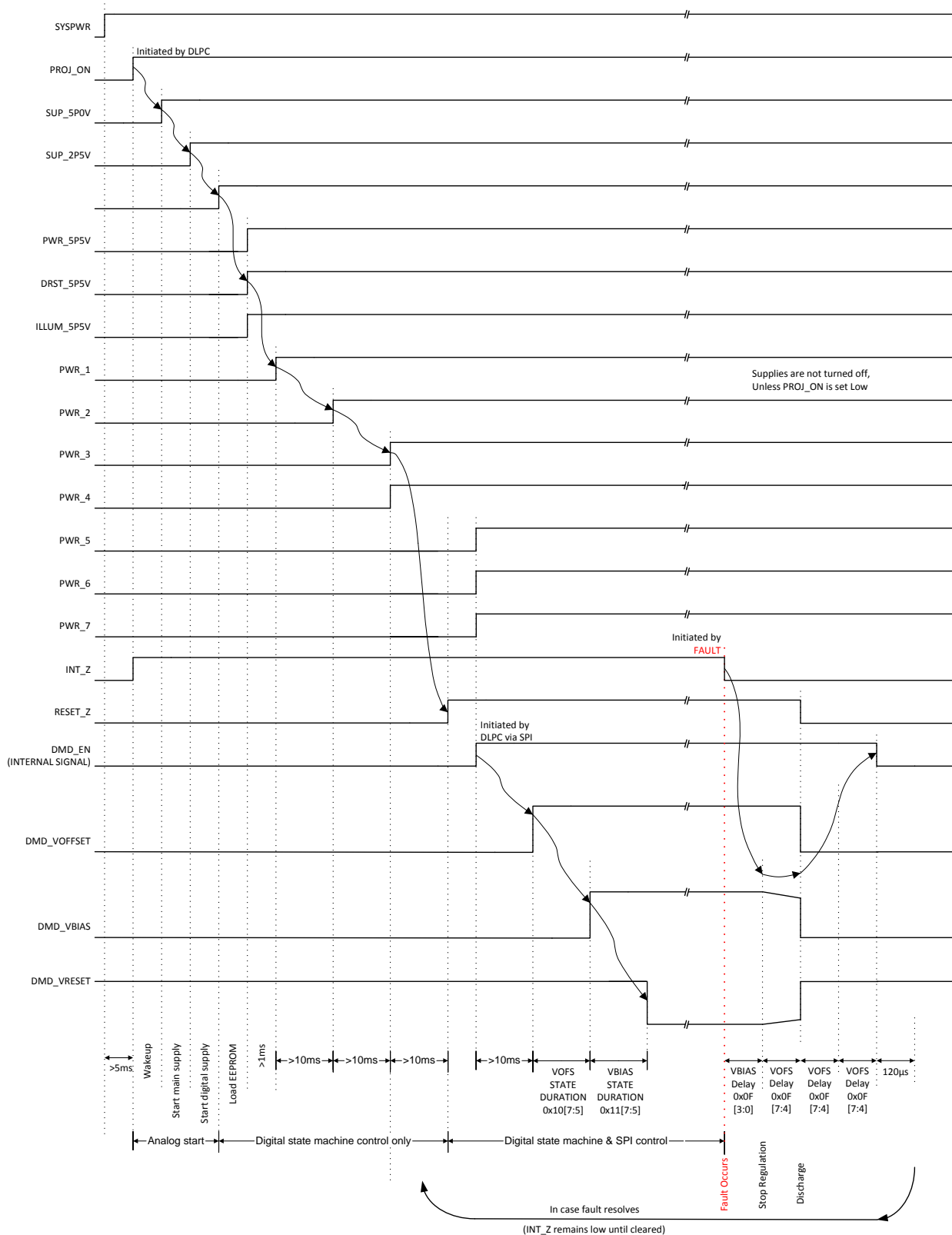

A. Arrows indicate sequence of events automatically controlled by digital state machine. Other events are initiated under SPI control.

Figure 19. Power Sequence Fault Fast Shutdown Mode

### 7.3.3.3 DMD/DLPC Buck Converters

Each of the two DMD buck converters creates a supply voltage for the DMD and/or the DLPC. The values of the voltages for the TRP-type of DMD and DLPC used, for instance:

- TRP DMD+DLPC3438: 1.1 V (DLPC) and 1.8 V (DLPC/DMD)

The topology of the buck converters is the same as the general purpose buck converters discussed later in this document. To configure the inductor and capacitor, see [Buck Converters](#).

A typical configuration is 3.3  $\mu$ H for the inductor and 2  $\times$  22  $\mu$ F for the output capacitor.

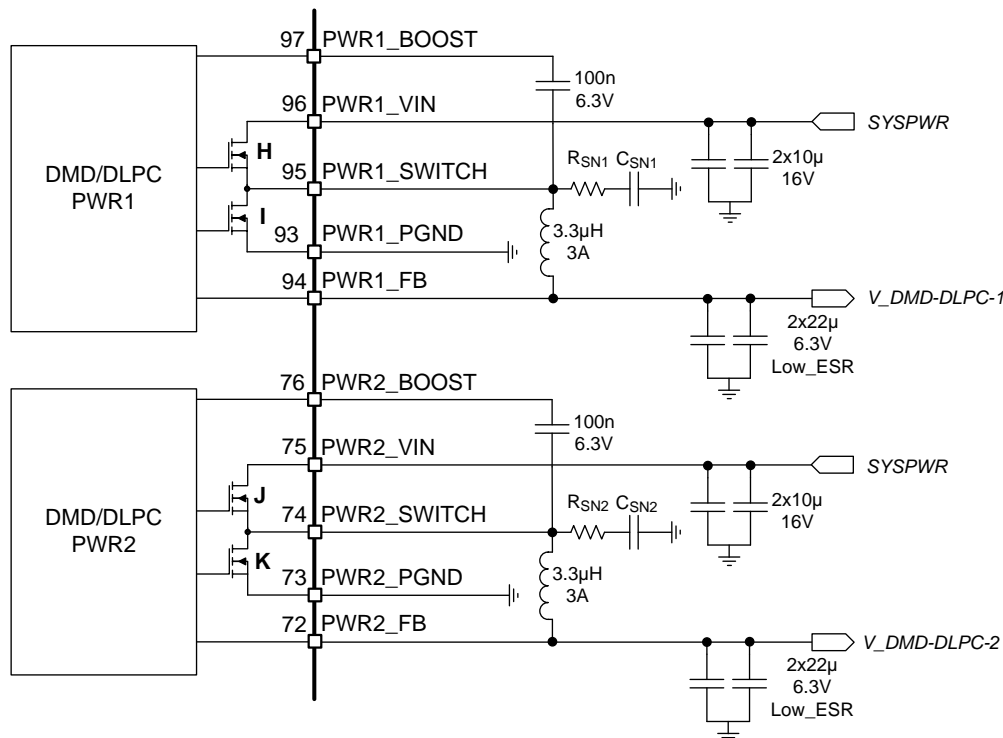

Figure 20. DMD/DLPC Buck Converters

### 7.3.3.4 DMD Monitoring

The DMD block is continuously monitored for failures to prevent damage to the DLPA3000 and/or the DMD. Several possible failures are monitored such that the DMD voltages can be guaranteed. Failures could be, for instance, a broken control loop or a too-high or too-low converter output voltage. The overall DMD fault bit is in register 0x0C, DMD\_FAULT. If any of the failures in [Table 2](#) occur, the DMD\_FAULT bit will be set high.

**Table 2. DMD FAULT Indication**

POWER GOOD (REGISTER 0x29)		
BLOCK	REGISTER BIT	THRESHOLD
HV Regulator	DMD_PG_FAULT	DMD_RESET: 90%, DMD_OFFSET and DMD_VBIAS: 86% rising, 66% falling
PWR1	BUCK_DMD1_PG_FAULT	Ratio: 72%
PWR2	BUCK_DMD2_PG_FAULT	Ratio: 72%
PWR3 (LDO_2)	LDO_GP2_PG_FAULT / LDO_DMD1_PG_FAULT	80% rising, 60% falling
PWR4 (LDO_1)	LDO_GP1_PG_FAULT / LDO_DMD1_PG_FAULT	80% rising, 60% falling
OVER-VOLTAGE (REGISTER 0x2A)		
BLOCK	REGISTER BIT	THRESHOLD (V)
PWR1	BUCK_DMD1_OV_FAULT	Ratio: 120%
PWR2	BUCK_DMD2_OV_FAULT	Ratio: 120%
PWR3 (LDO_2)	LDO_GP2_OV_FAULT / LDO_DMD1_OV_FAULT	7
PWR4 (LDO_1)	LDO_GP1_OV_FAULT / LDO_DMD1_OV_FAULT	7

#### 7.3.3.4.1 Power Good

The DMD HV regulator, DMD buck converters, DMD LDOs and the LDO\_DMD that supports the HV regulator, all have a power good indication.

The DMD HV regulator is continuously monitored to check if the output rails DMD\_RESET, DMD\_VOFFSET and DMD\_VBIAS are in regulation. If either one of the output rails drops out of regulation (for example, due to a shorted output or overloading), the DMD\_PG\_FAULT bit in register 0x29 is set. The threshold for DMD\_RESET is 90% and the thresholds for DMD\_OFFSET and DMD\_VBIAS are 86% (rising edge) and 66% (falling edge).

The power good signal for the two DMD buck converters indicate if their output voltage (PWR1\_FB and PWR2\_FB) are within a defined window. The relative power good ratio is 72%. This means that if the output voltage is below 72% of the set output voltage, the power good bit is asserted. The power good bits are in register 0x29, BUCK\_DMD1\_PG\_FAULT and BUCK\_DMD2\_PG\_FAULT.

DMD\_LDO1 and DMD\_LDO2 output voltages are also monitored. When the power good fault of the LDO is asserted, it implies that the LDO voltage is below 80% (rising edge) or 60% (falling edge) of its intended value. The power good indication for the LDOs is in register 0x29, LDO\_GP1\_PG\_FAULT / LDO\_DMD1\_PG\_FAULT and LDO\_GP2\_PG\_FAULT / LDO\_DMD2\_PG\_FAULT.

The LDO\_DMD used for the DMD HV regulator has its own power good signaling. The power good fault of the LDO\_DMD is asserted if the LDO voltage is below 80% (rising edge) or 60% (falling edge) of its intended value. The power good indication for this LDO is in register 0x29, V5V5\_LDO\_DMD\_PG\_FAULT.

#### 7.3.3.4.2 Overvoltage Fault

An overvoltage fault occurs when an output voltage rises above a pre-defined threshold. Overvoltage faults are indicated for the DMD buck converters, DMD LDOs and the LDO\_DMD supporting the DMD HV regulator. The overvoltage fault of LDO1 and LDO2 are not incorporated in the overall DMD\_FAULT when the LDOs are used as general purpose LDOs. [Table 2](#) provides an overview of the possible DMD overvoltage faults and their threshold levels.

### 7.3.4 Buck Converters

The DLPA3000 contains three general purpose buck converters and a supporting LDO (LDO\_BUCKS). The three programmable 8-bit buck converters can generate a voltage between 1 V and 5 V and have an output current limit of 3 A. One of the buck converters and the LDO\_BUCKS is depicted in Figure 21.

The two DMD/DLPC buck converters discussed earlier in the DMD section have the same architecture as these three buck converters and can be configured in the same way.

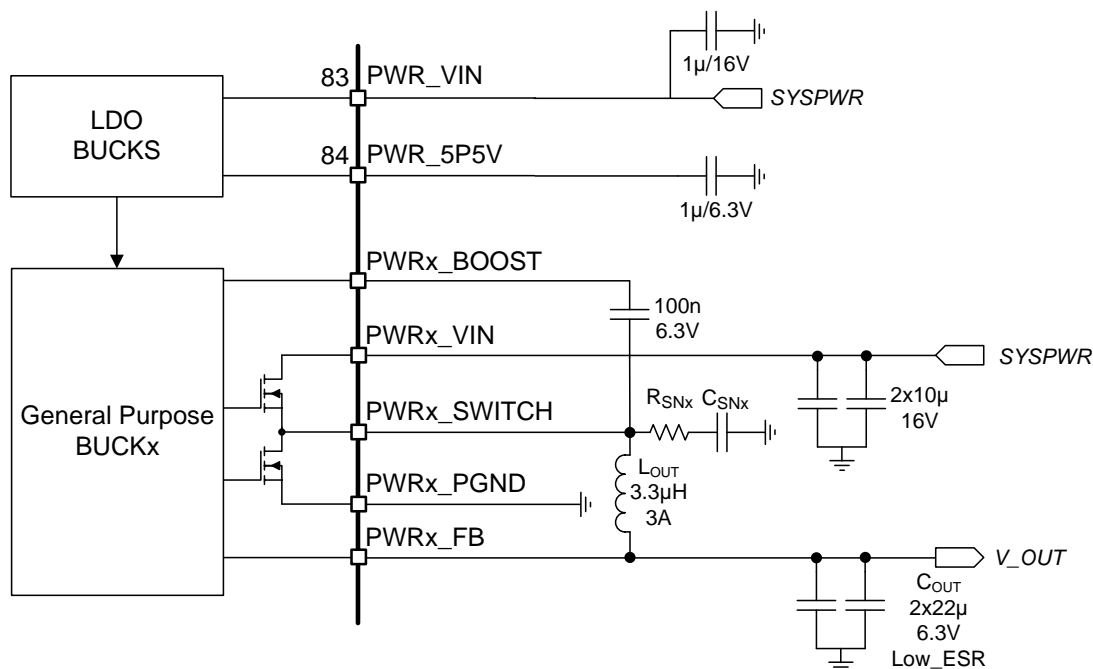

Figure 21. Buck Converter

#### 7.3.4.1 LDO Bucks

This regulator supports the 3 general purpose buck converters and the two DMD/DLPC buck converters and provides an analog voltage of 5.5 V to the internal circuitry. It is recommended to use a 1 µF/16 V capacitor on the input and a 1 µF/6.3 V capacitor on the output of the LDO.

#### 7.3.4.2 General Purpose Buck Converters

The three buck converters are for general purpose usage (Figure 21). Each of the converters can be enabled or disabled through register 0x01 bit:

- BUCK\_GP1\_EN
- BUCK\_GP2\_EN
- BUCK\_GP3\_EN

The output voltages of the converters are configurable between 1 V and 5 V with an 8-bit resolution. This can be done through registers 0x13, 0x14, and 0x15.

General Purpose Buck2 (PWR6) has a current capability of 2 A. Other General Purpose Buck converters (PWR5, 7) are not supported at this time; they will become available in the future.

The buck converters can operate in two switching modes: normal (600-kHz switching frequency) mode and the skip mode. The skip mode is designed to increase light load efficiency. As the output current decreases from heavy load condition, the inductor current is also reduced and eventually comes to point that its rippled valley touches zero level, which is the boundary between continuous conduction and discontinuous conduction modes. The rectifying MOSFET is turned off when its zero inductor current is detected. As the load current further decreases, the converter runs into discontinuous conduction mode. The on-time is kept almost the same as it was in the continuous conduction mode so that it takes longer time to discharge the output capacitor with smaller load current to the level of the reference voltage. The skip mode can be enabled or disabled per buck converter in register 0x16.

The theory of operation of a buck converter is explained in *Understanding Buck Power Stages in Switchmode Power Supplies (SLVA057)*. This section will therefore be limited to the component selection. For proper operation, selection of the external components is very important, especially the inductor  $L_{OUT}$  and the output capacitor  $C_{OUT}$ . For best efficiency and ripple performance, an inductor and capacitor should be chosen with low equivalent series resistance (ESR).

The component selection of the buck converter is mainly determined by the output voltage. [Table 3](#) shows the recommended value for inductor  $L_{OUT}$  and capacitor  $C_{OUT}$  for a given output voltage.

**Table 3. Recommended Buck Converter  $L_{OUT}$  and  $C_{OUT}$**

$V_{OUT}$ (V)	$L_{OUT}$ ( $\mu$ H)			$C_{OUT}$ ( $\mu$ F)	
	MIN	TYP	MAX	MIN	MAX
1 - 1.5	1.5	2.2	4.7	22	68
1.5 - 3.3	2.2	3.3	4.7	22	68
3.3 - 5	3.3		4.7	22	68

The inductor peak-to-peak ripple current, peak current, and RMS current can be calculated using [Equation 6](#), [Equation 7](#), and [Equation 8](#) respectively. The inductor saturation current rating must be greater than the calculated peak current. Likewise, the RMS or heating current rating of the inductor must be greater than the calculated RMS current. The switching frequency of the buck converter is approximately 600 kHz ( $f_{SWITCH}$ ).

$$I_{L\_OUT\_RIPPLE\_P-P} = \frac{V_{OUT}}{V_{IN\_MAX}} \cdot (V_{IN\_MAX} - V_{OUT})$$

$$L_{OUT} \cdot f_{SWITCH} \tag{6}$$

$$I_{L\_OUT\_PEAK} = I_{L\_OUT} + \frac{I_{L\_OUT\_RIPPLE\_P-P}}{2} \tag{7}$$

$$I_{L\_OUT(RMS)} = \sqrt{I_{L\_OUT}^2 + \frac{1}{12} \cdot I_{L\_OUT\_RIPPLE\_P-P}^2} \tag{8}$$

The capacitor value and ESR determines the level of output voltage ripple. The buck converter is intended for use with ceramic or other low ESR capacitors. Recommended values range from 22 to 68  $\mu$ F. [Equation 9](#) can be used to determine the required RMS current rating for the output capacitor.

$$I_{C\_OUT(RMS)} = \frac{V_{OUT} \cdot (V_{IN} - V_{OUT})}{\sqrt{12} \cdot V_{IN} \cdot L_{OUT} \cdot f_{SWITCH}} \tag{9}$$

Two other components need to be selected in the buck converter configuration. The value of the input-capacitor (pin PWRx\_VIN) should be equal or greater than half the selected output capacitance  $C_{OUT}$ . In this case  $C_{IN}$  2  $\times$  10  $\mu$ F is sufficient. The capacitor between PWRx\_SWITCH and PWRx\_BOOST is a charge pump capacitor to drive the high side FET. The recommended value is 100 nF.

Since the switching edges of the buck converter are relatively fast, voltage overshoot and ringing can become a problem. To overcome this problem a snubber network is used. The snubber circuit consists of a resistor and capacitor that are connected in series from the switch node to ground. The snubber circuit is used to damp the parasitic inductances and capacitances during the switching transitions. This circuit reduces the ringing voltage and also reduces the number of ringing cycles. The snubber network is formed by RSNx and CSNx. More information on controlling switch-node ringing in synchronous buck converters and configuring the snubber can be found in *Analog Application Journal 2Q 2012 (SLYT464)*.

### 7.3.4.3 Buck Converter Monitoring

The buck converter block is continuously monitored for system failures to prevent damage to the DLPA3000 and peripherals. Several possible failures are monitored such as a too-high or too-low output voltage. The possible faults are summarized in [Table 4](#).

**Table 4. Buck Converter Fault Indication**

POWER GOOD (REGISTER 0X27)		
BLOCK	REGISTER BIT	THRESHOLD (RISING EDGE)
Gen.Buck1	BUCK_GP1_PG_FAULT	Ratio 72%
Gen.Buck2	BUCK_GP2_PG_FAULT	Ratio 72%
Gen.Buck3	BUCK_GP3_PG_FAULT	Ratio 72%
OVERVOLTAGE (REGISTER 0X28)		
Gen.Buck1	BUCK_GP1_OV_FAULT	Ratio 120%
Gen.Buck2	BUCK_GP2_OV_FAULT	Ratio 120%
Gen.Buck3	BUCK_GP3_OV_FAULT	Ratio 120%

#### 7.3.4.3.1 Power Good

The buck converters as well as the supporting LDO\_BUCK have a power good indication. Each buck converter has a separate indication.

The power good for the three buck converters indicate if their output voltage (PWR5,6,7\_FB) is within a defined window. The relative power good ratio is 72%. This means that if the output voltage is below 72% of the set voltage the PG\_fault bit is set high. The power good bits of the buck converters are in register 0x27 bit:

- BUCK\_GP1\_PG\_FAULT for BUCK1 (PWR5)
- BUCK\_GP2\_PG\_FAULT for BUCK2 (PWR6)
- BUCK\_GP3\_PG\_FAULT for BUCK3 (PWR7)

The LDO\_BUCKS that supports the buck converters has its own power good indication. The power good of the LDO\_BUCKS is asserted if the LDO voltage is below 80% (rising edge) or 60% (falling edge) of its intended value. The power good indication for the LDO\_BUCKS is in register 0x29, V5V5\_LDO\_BUCK\_PG\_FAULT.

#### 7.3.4.3.2 Overvoltage Fault

An overvoltage fault occurs when an output voltage rises above a pre-defined threshold. Overvoltage faults are indicated for the buck converters, and LDO\_BUCKS. The overvoltage fault of the LDO\_BUCKS is asserted if the LDO voltage is above 7.2 V and can be found in register 0x2A, V5V5\_LDO\_BUCK\_OV\_FAULT. The overvoltage of the general purpose buck converters is 120% of the set value and can be read through register 0x28, BUCK\_GP1,2,3\_OV\_FAULT.

### 7.3.4.4 Buck Converter Efficiency

An overview of the efficiency of the buck converter for an input voltage of 12 V is provided in Figure 22. The efficiency is shown for several output voltage levels where the load current is swept.

Figure 23 depicts the buck converter efficiency versus input voltage ( $V_{IN}$ ) for a load current ( $I_{OUT}$ ) of 1 A for various output voltage levels ( $V_{OUT}$ ).

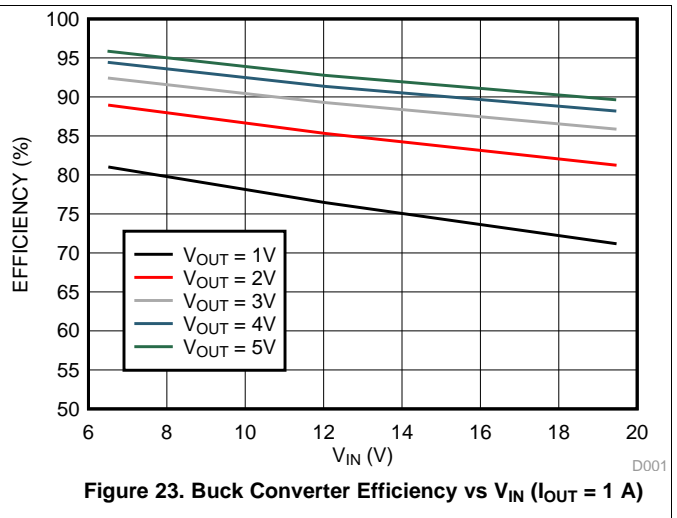
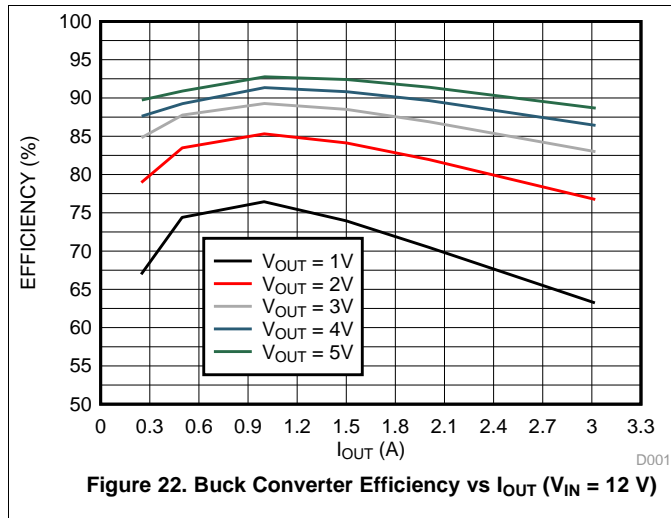

### 7.3.5 Auxiliary LDOs

LDO\_1 and LDO\_2 are the two auxiliary LDOs that can freely be used by an additional external application. All other LDOs are for internal usage only and should not be loaded. LDO1 (PWR4) is a fixed voltage of 3.3 V, while LDO2 (PWR3) is a fixed voltage of 2.5 V. Both LDOs are capable to deliver 200 mA.

### 7.3.6 Measurement System

The measurement system (Figure 24) is designed to sense internal and external nodes and convert them to digital by the implemented AFE comparator. The AFE can be enabled through register 0x0A, AFE\_EN. The reference signal for this comparator, ACMPR\_REF, is a low pass filtered PWM signal coming from the DLPC. To be able to cover a wide range of input signals, a variable gain amplifier (VGA) is added with 3 gain settings (1x, 9.5x, and 18x). The gain of the VGA can be set through register 0x0A, AFE\_GAIN. The maximum input voltage of the VGA is 1.5 V. However, some of the internal voltages are too large to be handled by the VGA and are divided down first.

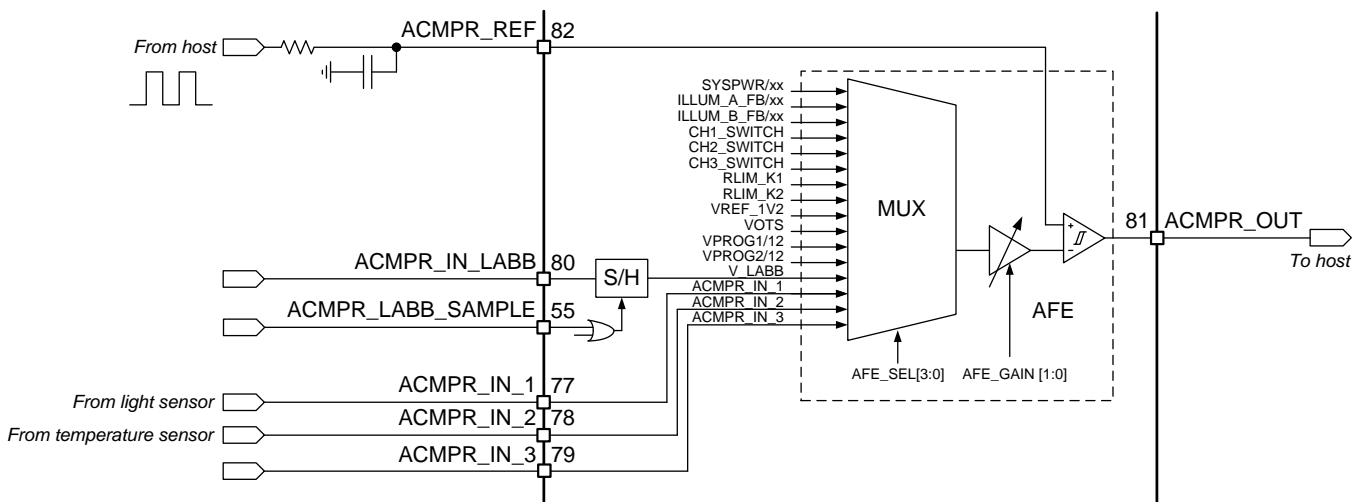

Figure 24. Measurement System

The multiplexer (MUX) connects to a wide range of nodes. Selection of the MUX input can be done through register 0x0A, AFE\_SEL. Signals that can be selected:

- System input voltage, SYSPWR
- LED anode cathode voltage, ILLUM\_A\_FB
- LED cathode voltage, CH<sub>x</sub>\_SWITCH
- V<sub>R\_LIM</sub> to measure LED current
- Internal reference, VREF\_1V2
- Die temperature represented by voltage VOTS
- EEPROM programming voltage, VPROG1,2/12
- LABB sensor, V\_LABB
- External sense pins, ACMPR\_IN\_1,2,3

The system input voltage SYSPWR can be measured by selecting the SYSPWR/xx input of the MUX. Before the system input voltage is supplied to the MUX, the voltage needs to be divided. This is because the variable gain amplifier (VGA) can handle voltages up to 1.5 V, whereas the system voltage can be as high as 20 V. The division is done internally in the DLPA3000. The division factor selection ( $V_{IN}$  division factor) is combined with the AUTO\_LED\_TURN\_OFF functionality of the illumination driver and can be set through register 0x18, ILLUM\_LED\_AUTO\_OFF\_SEL.

The LED voltages can be monitored by measuring both the common anode of the LEDs as well as the cathode of each LED individually. The LED anode voltage ( $V_{LED}$ ) is measured by sensing the feedback pin of the illumination driver (ILLUM\_A\_FB). Like the SYSPWR, the LED anode voltage needs to be divided before feeding it to the MUX. The division factor is combined with the overvoltage fault level of the illumination driver and can be set through register 0x19, VLED\_OVP\_VLED\_RATIO. The cathode voltages CH1,2,3\_SWITCH are fed directly to the MUX without division factor.

The LED current can be determined by knowing the value of sense resistor  $R_{LIM}$  and the voltage across the resistor. The voltage at the top-side of the sense resistor can be measured by selecting MUX-input RLIM\_K1. The bottom-side of the resistor is connected to GND.

VOTS is connected to an on-chip temperature sensor. The voltage is a measure for the junction temperature of the chip: Temperature (°C) = 300 × VOTS (V) – 270

For storage of trim bits, but also for the USER EEPROM bytes (0x30 to 0x35), the DLPA3000 has two EEPROM blocks. The programming voltage of EEPROM block 1 and 2 can be measured through MUX input VPROG1/12 and VPROG2/12, respectively. The EEPROM programming voltage is divided by 12 before it is supplied to the MUX to prevent a too-large voltage on the MUX input. The EEPROM programming voltage is ≈12 V.

LABB is a feature that stands for Local Area Brightness Boost. LABB locally increases the brightness while maintaining good contrast and saturation. The sensor needed for this feature should be connected to pin ACMPR\_IN\_LABB. The light sensor signal is sampled and held such that it can be read independently of the sensor timing. To use this feature, it should be ensured that:

- The AFE block is enabled (0x0A, AFE\_EN = 1)
- The LABB input is selected (0x0A, AFE\_SEL<3:0>=3h)
- The AFE gain is set appropriately to have AFE\_Gain × VLABB < 1.5 V (0x0A, AFE\_GAIN<1:0>)

Sampling of the signal can be done through one of the following methods:

1. Writing to register 0x0B by specifying the sample time window (TSAMPLE\_SEL) and set bit SAMPLE\_LABB=1 to start sampling. The SAMPLE\_LABB bit in register 0x0B is automatically reset to 0 at the end of the sample period to be ready for a next sample request.
2. Use the input ACMPR\_LABB\_SAMPLE-pin as a sample signal. As long as this signal is high, the signal on ACMPR\_IN\_LABB is tracked. Once the ACMPR\_LABB\_SAMPLE is set low again, the value at that moment will be held.

ACMPR\_IN\_1,2,3 can measure external signals from for instance a light sensor or a temperature sensor. It should be ensured that the voltage on the input does not exceed 1.5 V.

### 7.3.7 Digital Control

This section discusses the serial protocol interface (SPI) of the DLPA3000, as well as the interrupt handling, device shutdown, and register protection.

#### 7.3.7.1 SPI

The DLPA3000 provides a 4-wire SPI port that supports two SPI clock frequency modes: 0 MHz to 36 MHz, and 20 MHz to 40MHz. The clock frequency mode can be set in register 0x17, DIG\_SPI\_FAST\_SEL. The interface supports both read and write operations. The SPI\_SS\_Z input serves as the active low chip select for the SPI port. The SPI\_SS\_Z input must be forced low for writing to or reading from registers. When SPI\_SS\_Z is forced high, the data at the SPI\_MOSI input is ignored, and the SPI\_MISO output is forced to a high-impedance state. The SPI\_MOSI input serves as the serial data input for the port; the SPI\_MISO output serves as the serial data output. The SPI\_CLK input serves as the serial data clock for both the input and output data. Data at the SPI\_MOSI input is latched on the rising edge of SPI\_CLK, while data is clocked out of the SPI\_MISO output on the falling edge of SPI\_CLK. [Figure 25](#) illustrates the SPI port protocol. Byte 0 is referred to as the command byte, where the most significant bit is the write/not-read bit. For the W/nR bit, a 1 indicates a write operation, while a 0 indicates a read operation. The remaining seven bits of the command byte are the register address targeted by the write or read operation. The SPI port supports write and read operations for multiple sequential register addresses through the implementation of an auto-increment mode. As shown in [Figure 25](#), the auto-increment mode is invoked by simply holding the SPI\_SS\_Z input low for multiple data bytes. The register address is automatically incremented after each data byte transferred, starting with the address specified by the command byte. After reaching address 0x7Fh, the address pointer jumps back to 0x00h.

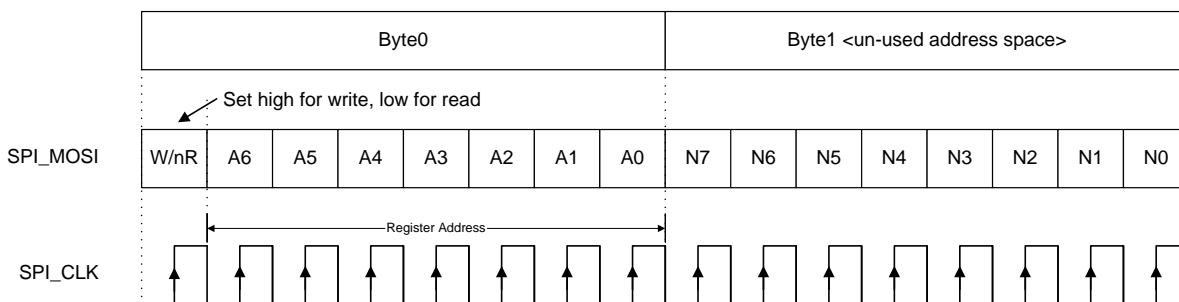
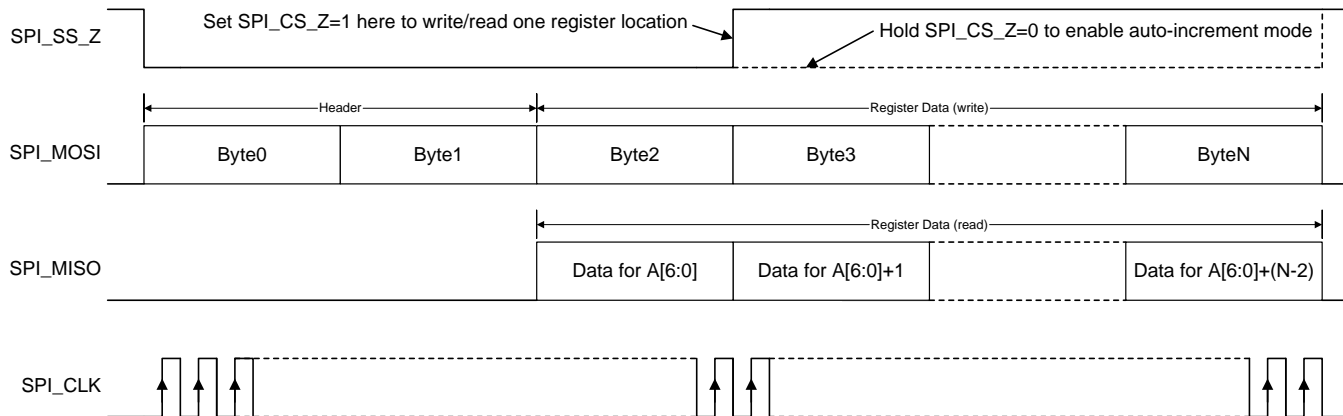

Figure 25. SPI Protocol

### 7.3.7.2 Interrupt

The DLPA3000 has the capability to flag for several faults in the system, such as overheating, low battery, power good, and overvoltage faults. If a certain fault condition occurs, one or more bits in the interrupt register (0x0C) will be set. The setting of a bit in register 0x0C will trigger an interrupt event, which will pulldown the INT\_Z pin. Interrupts can be masked by setting the respective MASK bits in register 0x0D. Setting a MASK bit will prevent that the INT\_Z is pulled low for the particular fault condition. Some high-level faults are composed of multiple low-level faults. The high-level faults can be read in register 0x0C, while the lower-level faults can be read in registers 0x027 through 0x2A. An overview of the faults and how they are related is given in [Table 5](#).

**Table 5. Interrupt Registers**

HIGH-LEVEL	MID-LEVEL	LOW-LEVEL
SUPPLY_FAULT	DMD_FAULT	DMD_PG_FAULT
		BUCK_DMD1_PG_FAULT
		BUCK_DMD1_OV_FAULT
		BUCK_DMD2_PG_FAULT
		BUCK_DMD2_OV_FAULT
		LDO_GP1_PG_FAULT / LDO_DMD1_PG_FAULT
		LDO_GP1_OV_FAULT / LDO_DMD1_OV_FAULT
		LDO_GP2_PG_FAULT / LDO_DMD2_PG_FAULT
		LDO_GP2_OV_FAULT / LDO_DMD2_OV_FAULT
	BUCK_GP1_PG_FAULT	
	BUCK_GP1_OV_FAULT	
	BUCK_GP2_PG_FAULT	
	BUCK_GP2_OV_FAULT	
	BUCK_GP3_PG_FAULT	
BUCK_GP3_OV_FAULT		
ILLUM_FAULT	ILLUM_BC1_PG_FAULT	
	ILLUM_BC1_OV_FAULT	
	ILLUM_BC2_PG_FAULT	
	ILLUM_BC2_OV_FAULT	
PROJ_ON_INT		
BAT_LOW_SHUT		
BAT_LOW_WARN		
TS_SHUT		
TS_WARN		

### 7.3.7.3 Fast-Shutdown in Case of Fault

The DLPA3000 has two shutdown modes: a normal shutdown initiated after pulling PROJ\_ON level low, and a fast power-down mode. The fast power-down feature can be enabled or disabled through register 0x01, FAST\_SHUTDOWN\_EN. By default, the mode is enabled.

When the fast power-down feature is enabled, a fast shutdown is initiated for specific faults. This shutdown happens autonomously from the DLPC. The DLPA3000 enters the fast shutdown mode only for specific faults, thus not for all the faults flagged by the DLPA3000. The faults for which the DLPA3000 goes into fast-shutdown are listed in [Table 6](#).

**Table 6. Faults hat Trigger a Fast-Shutdown**

HIGH-LEVEL	LOW-LEVEL
BAT_LOW_SHUT	
TS_SHUT	
DMD_FAULT	DMD_PG_FAULT
	BUCK_DMD1_PG_FAULT
	BUCK_DMD1_OV_FAULT
	BUCK_DMD2_PG_FAULT
	BUCK_DMD2_OV_FAULT
	LDO_GP1_PG_FAULT / LDO_DMD1_PG_FAULT
	LDO_GP1_OV_FAULT / LDO_DMD1_OV_FAULT
	LDO_GP2_PG_FAULT / LDO_DMD2_PG_FAULT
	LDO_GP2_OV_FAULT / LDO_DMD2_OV_FAULT
ILLUM_FAULT	ILLUM_BC1_OV_FAULT
	ILLUM_BC2_OV_FAULT

### 7.3.7.4 Protected Registers

By default, all regular USER registers are writable, except for the READ ONLY registers. Registers can be protected though to prevent accidental write operations. By enabling the protecting, only USER registers 0x02 through 0x09 are writable. Protection can be enabled/ disabled through register 0x2F, PROTECT\_USER\_REG.

### 7.3.7.5 Writing to EEPROM

The DLPA3000 has an EEPROM mainly intended for default settings and factory trimming parameters. Registers 0x30 through 0x35 can freely be used for customer convenience, though, to write a serial number or version information for instance. Writing to EEPROM requires a couple of steps. First, the EEPROM needs to be unlocked. Unlock the EEPROM by writing 0xBAh to register 0x2E followed by writing 0xBE to the same register. Both writes must be consecutive; in other words, there must be no other read or write operation in between sending these two bytes. Once the password has been successfully written, registers 0x30h through 0x35h are unlocked and can be write-accessed using the regular SPI protocol. They remain unlocked until any byte other than 0xBABE is written to PASSWORD register 0x2E or the part is power-cycled. To permanently store the written data in EEPROM, write a 1 to register 0x2F, EEPROM\_PROGRAM, more than 250 ms later, followed by writing a 0 to the same register.

To check if the registers are unlocked, read back the PASSWORD register 0x2E. If the data returned is 0x00h, the registers are locked. If the PASSWORD register returns 0x01h, the registers are unlocked.

## 7.4 Device Functional Modes

**Table 7. Modes of Operation**

MODE	DESCRIPTION
OFF	This is the lowest-power mode of operation. All power functions are turned off, registers are reset to their default values, and the IC does not respond to SPI commands. RESET_Z pin is pulled low. The IC will enter OFF mode whenever the PROJ_ON pin is low.
WAIT	The DMD regulators and LED power ( $V_{LED}$ ) are turned off, but the IC does respond to the SPI. The device enters WAIT mode whenever PROJ_ON is set high, DMD_EN <sup>(1)</sup> bit is set to 0 or a FAULT is resolved.
STANDBY	The device also enters STANDBY mode when a fault condition is detected. <sup>(2)</sup> (See <i>Interrupt</i> ). Once the fault condition is resolved, WAIT mode is entered.
ACTIVE1	The DMD supplies are enabled but LED power ( $V_{LED}$ ) is disabled. PROJ_ON pin must be high, DMD_EN bit must be set to 1, and ILLUM_EN <sup>(3)</sup> bit is set to 0.
ACTIVE2	DMD supplies and LED power are enabled. PROJ_ON pin must be high and DMD_EN and ILLUM_EN bits must both be set to 1.

(1) Settings can be done through register 0x01

(2) Power-good faults, overvoltage, over-temperature shutdown, and undervoltage lockout

(3) Settings can be done through register 0x01, bit is named ILLUM\_EN

**Table 8. Device State as a Function of Control-Pin Status**

PROJ_ON Pin	STATE
LOW	OFF
HIGH	WAIT STANDBY ACTIVE1 ACTIVE2 (Device state depends on DMD_EN and ILLUM_EN bits and whether there are any fault conditions.)

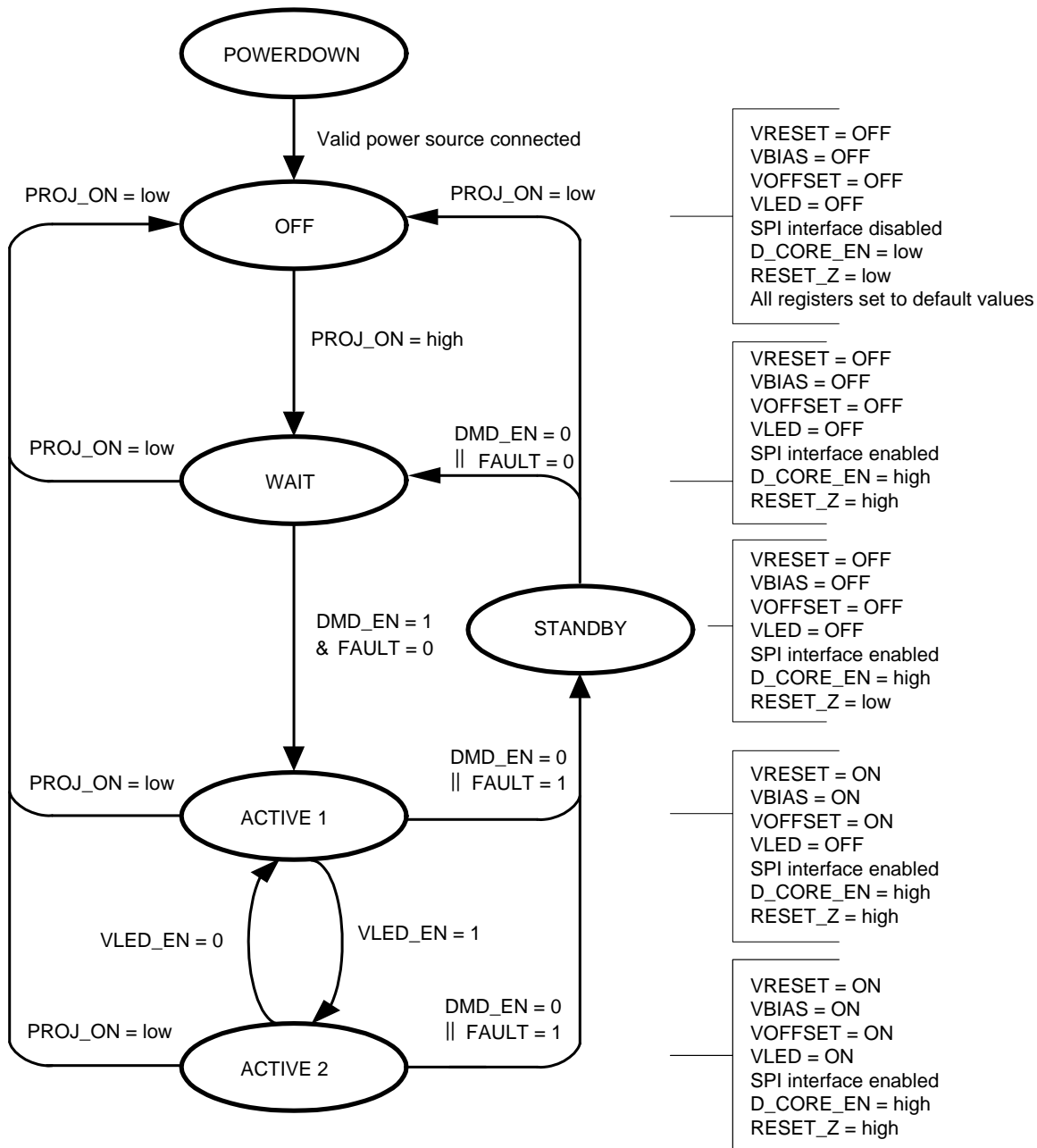

- A. || = OR, & = AND
- B. FAULT = Undervoltage on any supply, thermal shutdown, or UVLO detection
- C. UVLO detection, per the diagram, causes the DLPA3000 to go into the standby state. This is not the lowest power state. If lower power is desired, PROJ\_ON should be set low.
- D. DMD\_EN register bit can be reset or set by SPI writes. DMD\_EN defaults to 0 when PROJ\_ON goes from low to high and then the DPP ASIC software automatically sets it to 1. Also, FAULT = 1 causes the DMD\_EN register bit to be reset.
- E. D\_CORE\_EN is a signal internal to the DLPA3000. This signal turns on the VCORE regulator.

Figure 26. State Diagram

## 7.5 Register Maps

Register Address, Default, R/W, Register name. **Boldface** settings are the hardwired defaults.

**Table 9. Register Map**

NAME	BITS	DESCRIPTION
<b>0x00, D3, R/W, Chip Identification</b>		
CHIPID	[7:4]	Chip identification number: D (hex)
REVID	[3:0]	Revision number, 3 (hex)
<b>0x01, 82, R/W, Enable Register</b>		
FAST_SHUTDOWN_EN	[7]	0: Fast shutdown disabled <b>1: Fast shutdown enabled</b>
CW_EN	[6]	<b>0: Color wheel circuitry disabled</b> 1: Color wheel circuitry enabled
BUCK_GP3_EN	[5]	<b>0: General purpose buck3 disabled</b> 1: General purpose buck3 enabled
BUCK_GP2_EN	[4]	<b>0: General purpose buck2 disabled</b> 1: General purpose buck2 enabled
BUCK_GP1_EN	[3]	<b>0: General purpose buck1 disabled</b> 1: General purpose buck1 enabled
ILLUM_LED_AUTO_OFF_EN	[2]	<b>0: Illum_led_auto_off_en disabled</b> 1: Illum_led_auto_off_en enabled
ILLUM_EN	[1]	0: Illum regulators disabled <b>1: Illum regulators enabled</b>
DMD_EN	[0]	<b>0: DMD regulators disabled</b> 1: DMD regulators enabled
<b>0x02, 70, R/W, IREG Switch Control</b>		
TBD	[7]	Reserved, value does not matter.
ILLUM_ILIM	[6:3]	Rlim voltage top-side (mV). Illum current limit = Rlim voltage / Rlim
		0000: 17                      1000: 73
		0001: 20                      1001: 88
		0010: 23                      1010: 102
		0011: 25                      1011: 117
		0100: 29                      1100: 133
		0101: 37                      1101: 154
		0110: 44 <b>1110: 176</b>
0111: 59                      1111: 197		
ILLUM_SW_ILIM_EN	[2:0]	Bit2: CH3, MOSFET R transient current limit ( <b>0:disabled</b> , 1:enabled) Bit1: CH2, MOSFET Q transient current limit ( <b>0:disabled</b> , 1:enabled) Bit0: CH1, MOSFET P transient current limit ( <b>0:disabled</b> , 1:enabled)
<b>0x03, 00, R/W, SW1_IDAC(1)</b>		
TBD	[7:2]	Reserved, value does not matter.
SW1_IDAC<9:8>	[1:0]	Led current of CH1(A) = ((Bit value + 1)/1024) × (150 mV / Rlim), Most significant bits of 10 bits register (register 0x03 and 0x04). <b>00 0000 0000 [OFF]</b> 00 0011 0011 [(52/1024) × (150mV/Rlim)], Minimum code. .... 11 1111 1111 [150mV/Rlim]
<b>0x04, 00, R/W, SW1_IDAC(2)</b>		
SW1_IDAC<7:0>	[7:0]	Led current of CH1(A) = ((Bit value + 1)/1024) × (150 mV / Rlim), Least significant bits of 10 bits register (register 0x03 and 0x04). <b>00 0000 0000 [OFF]</b> 00 0011 0011 [(52/1024) × (150mV/Rlim)], Minimum code. .... 11 1111 1111 [150mV/Rlim]

**Register Maps (continued)**
**Table 9. Register Map (continued)**

NAME	BITS	DESCRIPTION
<b>0x05, 00, R/W, SW2_IDAC(1)</b>		
TBD	[7:2]	Reserved, value does not matter.
SW2_IDAC<9:8>	[1:0]	Led current of CH2(A) = ((Bit value + 1)/1024) × (150 mV / Rlim), Most significant bits of 10 bits register (register 0x05 and 0x06). <b>00 0000 0000 [OFF]</b> 00 0011 0011 [(52/1024) × (150mV/Rlim)], Minimum code. ..... 11 1111 1111 [150mV/Rlim]
<b>0x06, 00, R/W, SW2_IDAC(2)</b>		
SW2_IDAC<7:0>	[7:0]	Led current of CH2(A) = ((Bit value + 1)/1024) × (150 mV / Rlim), Least significant bits of 10 bits register (register 0x05 and 0x06). <b>00 0000 0000 [OFF]</b> 00 0011 0011 [(52/1024) × (150mV/Rlim)], Minimum code. ..... 11 1111 1111 [150mV/Rlim]
<b>0x07, 00, R/W, SW3_IDAC(1)</b>		
TBD	[7:2]	Reserved, value does not matter.
SW3_IDAC<9:8>	[1:0]	Led current of CH3(A) = ((Bit value + 1)/1024) × (150 mV / Rlim), Most significant bits of 10 bits register (register 0x07 and 0x08). <b>00 0000 0000 [OFF]</b> 00 0011 0011 [(52/1024) × (150mV/Rlim)], Minimum code. ..... 11 1111 1111 [150mV/Rlim]
<b>0x08, 00, R/W, SW3_IDAC(2)</b>		
SW3_IDAC<7:0>	[7:0]	Led current of CH3(A) = ((Bit value + 1)/1024) × (150 mV / Rlim), Least significant bits of 10 bits register (register 0x07 and 0x08). <b>00 0000 0000 [OFF]</b> 00 0011 0011 [(52/1024) × (150mV/Rlim)], Minimum code. ..... 11 1111 1111 [150mV/Rlim]
<b>0x09, 00, R/W, Switch ON/OFF Control</b>		
SW3	[7]	Only used if DIRECT MODE is enabled (see register 0x2F) <b>0: SW3 disabled</b> 1: SW3 enabled
SW2	[6]	Only used if DIRECT MODE is enabled (see register 0x2F) <b>0: SW2 disabled</b> 1: SW2 enabled
SW1	[5]	Only used if DIRECT MODE is enabled (see register 0x2F) <b>0: SW1 disabled</b> 1: SW1 enabled
TBD	[4:0]	Reserved, value does not matter.
<b>0x0A, 00, R/W, Analog Front End (1)</b>		
AFE_EN	[7]	<b>0: Analog front end disabled</b> 1: Analog front end enabled
AFE_CAL_DIS	[6]	<b>0: Calibrated 18x AFE_VGA</b> 1: Uncalibrated 18x AFE_VGA
AFE_GAIN	[5:4]	Gain analog front end gain <b>00: Off</b> 01: 1x 10: 9.5x 11: 18x

**Register Maps (continued)**
**Table 9. Register Map (continued)**

NAME	BITS	DESCRIPTION																																
AFE_SEL	[3:0]	Selected analog multiplexer input <b>0000: ILLUM_A_FB/xx, where xx is controlled by VLED_OVP_VLED_RATIO&lt;4:0&gt; (reg0x19)</b> 0001: ILLUM_B_FB/xx, where xx is controlled by VLED_OVP_VLED_RATIO<4:0> (reg0x19) 0010: VIN/xx, where xx is controlled by ILLUM_LED_AUTO_OFF_SEL<3:0> (reg0x18) 0011: V_LABB 0100: RLIM_K1 0101: RLIM_K2 0110: CH1_SWITCH 0111: CH2_SWITCH 1000: CH3_SWITCH 1001: VREF_1V2 1010: VOTS (Main temperature sense block output voltage) 1011: VPROG1/12 (EEPROM block1 programming voltage divided by 12) 1100: VPROG2/12 (EEPROM block2 programming voltage divided by 12) 1101: ACMPR_IN_1 1110: ACMPR_IN_2 1111: ACMPR_IN_3																																
<b>0x0B, 00, R/W, Analog Front End (2)</b>																																		
TSAMPLE_SEL	[7:6]	Samples time LABB Sensor (µs) <b>00: 7</b> 01: 14 10: 21 11: 28																																
SAMPLE_LABB	[5]	<b>0: LABB SAMPLING disabled</b> 1: START LABB SAMPLING (auto reset to 0 after TSAMPLE_SEL time).																																
VLED_OVP_VIN_RATIO	[4:0]	OVP_VIN Division factor. <table border="1"> <tr> <td><b>00000: 3.33</b></td> <td>01000: 6.10</td> <td>10000: 9.16</td> <td>11000: 12.51</td> </tr> <tr> <td>00001: 4.98</td> <td>01001: 6.23</td> <td>10001: 9.60</td> <td>11001: 12.94</td> </tr> <tr> <td>00010: 5.23</td> <td>01010: 6.67</td> <td>10010: 9.99</td> <td>11010: 13.31</td> </tr> <tr> <td>00011: 5.32</td> <td>01011: 7.11</td> <td>10011: 10.41</td> <td>11011: 13.70</td> </tr> <tr> <td>00100: 5.42</td> <td>01100: 7.50</td> <td>10100: 10.88</td> <td>11100: 14.11</td> </tr> <tr> <td>00101: 5.52</td> <td>01101: 7.96</td> <td>10101: 11.26</td> <td>11101: 14.56</td> </tr> <tr> <td>00110: 5.62</td> <td>01110: 8.34</td> <td>10110: 11.67</td> <td>11110: 15.04</td> </tr> <tr> <td>00111: 5.85</td> <td>01111: 8.77</td> <td>10111: 12.11</td> <td>11111: 15.41</td> </tr> </table>	<b>00000: 3.33</b>	01000: 6.10	10000: 9.16	11000: 12.51	00001: 4.98	01001: 6.23	10001: 9.60	11001: 12.94	00010: 5.23	01010: 6.67	10010: 9.99	11010: 13.31	00011: 5.32	01011: 7.11	10011: 10.41	11011: 13.70	00100: 5.42	01100: 7.50	10100: 10.88	11100: 14.11	00101: 5.52	01101: 7.96	10101: 11.26	11101: 14.56	00110: 5.62	01110: 8.34	10110: 11.67	11110: 15.04	00111: 5.85	01111: 8.77	10111: 12.11	11111: 15.41
<b>00000: 3.33</b>	01000: 6.10	10000: 9.16	11000: 12.51																															
00001: 4.98	01001: 6.23	10001: 9.60	11001: 12.94																															
00010: 5.23	01010: 6.67	10010: 9.99	11010: 13.31																															
00011: 5.32	01011: 7.11	10011: 10.41	11011: 13.70																															
00100: 5.42	01100: 7.50	10100: 10.88	11100: 14.11																															
00101: 5.52	01101: 7.96	10101: 11.26	11101: 14.56																															
00110: 5.62	01110: 8.34	10110: 11.67	11110: 15.04																															
00111: 5.85	01111: 8.77	10111: 12.11	11111: 15.41																															
<b>0x0C, 00, R, Main Status Register</b>																																		
SUPPLY_FAULT	[7]	<b>0: No PG or OV failures for any of the LV Supplies</b> 1: PG failures for a LV Supplies																																
ILLUM_FAULT	[6]	<b>0: ILLUM_FAULT = LOW</b> 1: ILLUM_FAULT = HIGH																																
PROJ_ON_INT	[5]	<b>0: PROJ_ON = HIGH</b> 1: PROJ_ON = LOW																																
DMD_FAULT	[4]	<b>0: DMD_FAULT = LOW</b> 1: DMD_FAULT = HIGH																																
BAT_LOW_SHUT	[3]	<b>0: VIN &gt; UVLO_SEL&lt;4:0&gt;</b> 1: VIN < UVLO_SEL<4:0>																																
BAT_LOW_WARN	[2]	<b>0: VIN &gt; LOWBATT_SEL&lt;4:0&gt;</b> 1: VIN < LOWBATT_SEL<4:0>																																
TS_SHUT	[1]	<b>0: Chip temperature &lt; 132.5°C and no violation in V5V0</b> 1: Chip temperature > 156.5°C, or violation in V5V0																																
TS_WARN	[0]	<b>0: Chip temperature &lt; 121.4°C</b> 1: Chip temperature > 123.4°C																																

**Register Maps (continued)**
**Table 9. Register Map (continued)**

NAME	BITS	DESCRIPTION
<b>0x0D, F5, Interrupt Mask Register</b>		
SUPPLY_FAULT_MASK	[7]	0: Not masked for SUPPLY_FAULT interrupt <b>1: Masked for SUPPLY_FAULT interrupt</b>
ILLUM_FAULT_MASK	[6]	0: Not masked for ILLUM_FAULT interrupt <b>1: Masked for ILLUM_FAULT interrupt</b>
PROJ_ON_INT_MASK	[5]	0: Not masked for PROJ_ON_INT interrupt <b>1: Masked for PROJ_ON_INT interrupt</b>
DMD_FAULT_MASK	[4]	0: Not masked for DMD_FAULT interrupt <b>1: Masked for DMD_FAULT interrupt</b>
BAT_LOW_SHUT_MASK	[3]	<b>0: Not masked for BAT_LOW_SHUT interrupt</b> 1: Masked for BAT_LOW_SHUT interrupt
BAT_LOW_WARN_MASK	[2]	0: Not masked for BAT_LOW_WARN interrupt <b>1: Masked for BAT_LOW_WARN interrupt</b>
TS_SHUT_MASK	[1]	<b>0: Not masked for TS_SHUT interrupt</b> 1: Masked for TS_SHUT interrupt
TS_WARN_MASK	[0]	0: Not masked for TS_WARN interrupt <b>1: Masked for TS_WARN interrupt</b>
<b>0x0E, 00, R/W, Break-Before-Make Delay</b>		
BBM_DELAY	[7:0]	Break before make delay register (ns), step size is 111 ns <b>0000 0000: 0</b> 0000 0001: 333 0000 0010: 444 0000 0011: 555 ..... 1111 1101: 28305 1111 1110: 28416 1111 1111: 28527
<b>0x0F, 07, R/W, Fast Shutdown Timing</b>		
VOFS/RESETZ_DELAY	[7:4]	VOFS/RESETZ_DELAY (µs)
		<b>0000: 4.000 – 4.445</b> 1000: 6.230 – 7.120
		0001: 8.010 – 8.900    1001: 12.46 – 14.24
		0010: 16.02 – 17.80    1010: 24.89 – 28.44
		0011: 32.00 – 35.55    1011: 49.77 – 56.88
		0100: 63.99 – 71.10    1100: 99.5 – 113.8
		0101: 128.0 – 142.2    1101: 199.1 – 227.6
		0110: 256.0 – 284.5    1110: 398.3 – 455.2
0111: 512.1 – 569.0    1111: 1024.2 – 1138.0		
VBIAS/VRST_DELAY	[3:0]	VBIAS/VRST_DELAY (µs)
		0000: 4.000 – 4.445    1000: 6.230 – 7.120
		0001: 8.010 – 8.900    1001: 12.46 – 14.24
		0010: 16.02 – 17.80    1010: 24.89 – 28.44
		0011: 32.00 – 35.55    1011: 49.77 – 56.88
		0100: 63.99 – 71.10    1100: 99.5 – 113.8
		0101: 128.0 – 142.2    1101: 199.1 – 227.6
		0110: 256.0 – 284.5    1110: 398.3 – 455.2
<b>0111: 512.1 – 569.0</b> 1111: 1024.2 – 1138.0		

**Register Maps (continued)**
**Table 9. Register Map (continued)**

NAME	BITS	DESCRIPTION
<b>0x10, C0, R/W, VOFS State Duration</b>		
VOFS_STATE_DURATION	[7:5]	Duration of VOFS state (ms) 000: 1 001: 5 010: 10 011: 20 100: 40 101: 80 <b>110: 160</b> 111: 320
LOWBATT_SEL	[4:0]	Low battery level selection
		<b>00000: 3.93</b> 01000: 7.27      10000: 10.94      11000: 14.96
		00001: 5.92      01001: 7.43      10001: 11.46      11001: 15.47
		00010: 6.21      01010: 7.95      10010: 11.92      11010: 15.91
		00011: 6.32      01011: 8.46      10011: 12.42      11011: 16.37
		00100: 6.43      01100: 8.93      10100: 12.97      11100: 16.87
		00101: 6.55      01101: 9.47      10101: 13.42      11101: 17.40
		00110: 6.67      01110: 9.92      10110: 13.91      11110: 17.96
00111: 6.93      01111: 10.42      10111: 14.43      11111: 18.41		
<b>0x11, 00, R/W, VBIAS State Duration</b>		
VBIAS_STATE_DURATION	[7:5]	Duration of VBIAS state (ms) <b>000: bypass</b> 001: 5 010: 10 011: 20 100: 40 101: 80 110: 160 111: 320
UVLO_SEL	[4:0]	Undervoltage lockout level selection
		<b>00000: 3.93</b> 01000: 7.27      10000: 10.94      11000: 14.96
		00001: 5.92      01001: 7.43      10001: 11.46      11001: 15.47
		00010: 6.21      01010: 7.95      10010: 11.92      11010: 15.91
		00011: 6.32      01011: 8.46      10011: 12.42      11011: 16.37
		00100: 6.43      01100: 8.93      10100: 12.97      11100: 16.87
		00101: 6.55      01101: 9.47      10101: 13.42      11101: 17.40
		00110: 6.67      01110: 9.92      10110: 13.91      11110: 17.96
00111: 6.93      01111: 10.42      10111: 14.43      11111: 18.41		
<b>0x13, 00, R/W, GP1 Buck Converter Voltage Selection</b>		
BUCK_GP1_TRIM	[7:0]	General purpose1 buck output voltage = 1+ bit value * 15.69 (stepsize = 15.69 mV) <b>00000000 1 V</b> ..... 11111111 5 V
<b>0x14, 00, R/W, GP2 Buck Converter voltage Selection</b>		
BUCK_GP2_TRIM	[7:0]	General purpose2 buck output voltage = 1+ bit value * 15.69 (stepsize = 15.69 mV) <b>00000000 1 V</b> ..... 11111111 5 V
<b>0x15, 00, R/W, GP3 Buck Converter Voltage Selection</b>		
BUCK_GP3_TRIM	[7:0]	General purpose3 driver output voltage = 1+ bit value * 15.69 (stepsize = 15.69 mV) <b>00000000 1 V</b> ..... 11111111 5 V

**Register Maps (continued)**
**Table 9. Register Map (continued)**

NAME	BITS	DESCRIPTION																																																			
<b>0x16, 00, R/W, Buck Skip Mode</b>																																																					
TBD	[7:5]	Reserved, value does not matter.																																																			
BUCK_SKIP_ON	[4:0]	Skip Mode: Bit4: Buck_GP3 ( <b>0:disabled</b> , 1:enabled) Bit3: Buck_GP1 ( <b>0:disabled</b> , 1:enabled) Bit2: Buck_GP2 ( <b>0:disabled</b> , 1:enabled) Bit1: Buck_DMD1 ( <b>0:disabled</b> , 1:enabled) Bit0: Buck_DMD2 ( <b>0:disabled</b> , 1:enabled)																																																			
<b>0x17, 02, R/W, User Configuration Selection Register</b>																																																					
DIG_SPI_FAST_SEL	[7]	<b>0: SPI Clock from 0 to 36 MHz</b> 1: SPI Clock from 20 to 40 MHz																																																			
TBD	[6]	Reserved, value does not matter.																																																			
ILLUM_EXT_LSD_CUR_LIM_EN	[5]	<b>0: Current limiting disabled (External FETs mode)</b> 1: Current limiting enabled (External FETs mode)																																																			
Reserved	[4]																																																				
ILLUM_3A_INT_SWITCH_SEL	[3]	Illum Configuration: most significant bit is ILLUM_EXT_SWITCH_CAP<6> (Reg0x26). Other 4 bits are <3:0> of this register. "x" is don't care. x xx00: Off x x110: 2 x 3 A Internal FETs <b>x 0010: 1 x 6 A Internal FETs</b> x 1010: 1 x 3 A Internal FETs 0 xx0x: Off 0 x11x: 2 x 3 A Internal FETs 0 001x: 1 x 6 A Internal FETs 0 101x: 1 x 3 A Internal FETs 1 xxx1: External FETs																																																			
ILLUM_DUAL_OUTPUT_CNTR_SEL	[2]																																																				
ILLUM_INT_SWITCH_SEL	[1]																																																				
ILLUM_EXT_SWITCH_SEL	[0]																																																				
<b>0x18, 00, R/W, OLV -ILLUM_LED_AUTO_OFF_SEL</b>																																																					
ILLUM_OLV_SEL	[7:4]	Illum openloop voltage (V) = 3 + bit value * 1 (stepsize = 1 V) <b>0000: 3 V</b> 0001: 4 V ... 1110: 17 V 1111: 18 V																																																			
ILLUM_LED_AUTO_OFF_SEL	[3:0]	<table border="1"> <thead> <tr> <th>Bit value</th> <th>Led Auto Off Level (V)</th> <th>VIN division factor</th> </tr> </thead> <tbody> <tr> <td><b>0000</b></td> <td><b>3.93</b></td> <td><b>3.33</b></td> </tr> <tr> <td>0001</td> <td>5.92</td> <td>4.98</td> </tr> <tr> <td>0010</td> <td>6.21</td> <td>5.23</td> </tr> <tr> <td>0011</td> <td>6.32</td> <td>5.32</td> </tr> <tr> <td>0100</td> <td>6.43</td> <td>5.42</td> </tr> <tr> <td>0101</td> <td>6.55</td> <td>5.52</td> </tr> <tr> <td>0110</td> <td>6.67</td> <td>5.62</td> </tr> <tr> <td>0111</td> <td>6.93</td> <td>5.85</td> </tr> <tr> <td>1000</td> <td>7.27</td> <td>6.10</td> </tr> <tr> <td>1001</td> <td>7.95</td> <td>6.67</td> </tr> <tr> <td>1010</td> <td>8.93</td> <td>7.50</td> </tr> <tr> <td>1011</td> <td>9.92</td> <td>8.34</td> </tr> <tr> <td>1100</td> <td>10.94</td> <td>9.16</td> </tr> <tr> <td>1101</td> <td>11.92</td> <td>9.99</td> </tr> <tr> <td>1110</td> <td>12.97</td> <td>10.88</td> </tr> <tr> <td>1111</td> <td>13.91</td> <td>11.67</td> </tr> </tbody> </table>	Bit value	Led Auto Off Level (V)	VIN division factor	<b>0000</b>	<b>3.93</b>	<b>3.33</b>	0001	5.92	4.98	0010	6.21	5.23	0011	6.32	5.32	0100	6.43	5.42	0101	6.55	5.52	0110	6.67	5.62	0111	6.93	5.85	1000	7.27	6.10	1001	7.95	6.67	1010	8.93	7.50	1011	9.92	8.34	1100	10.94	9.16	1101	11.92	9.99	1110	12.97	10.88	1111	13.91	11.67
Bit value	Led Auto Off Level (V)	VIN division factor																																																			
<b>0000</b>	<b>3.93</b>	<b>3.33</b>																																																			
0001	5.92	4.98																																																			
0010	6.21	5.23																																																			
0011	6.32	5.32																																																			
0100	6.43	5.42																																																			
0101	6.55	5.52																																																			
0110	6.67	5.62																																																			
0111	6.93	5.85																																																			
1000	7.27	6.10																																																			
1001	7.95	6.67																																																			
1010	8.93	7.50																																																			
1011	9.92	8.34																																																			
1100	10.94	9.16																																																			
1101	11.92	9.99																																																			
1110	12.97	10.88																																																			
1111	13.91	11.67																																																			

Register Maps (continued)

Table 9. Register Map (continued)

NAME	BITS	DESCRIPTION
<b>0x19, 1F, R/W, Illumination Buck Converter Overvoltage Fault Level</b>		
Reserved	[7:5]	
VLED_OVP_VLED_RATIO	[4:0]	<b>Bit value / OVP VLED division factor</b>
		00000: 3.33      01000: 6.10      10000: 9.16      11000: 12.51
		00001: 4.98      01001: 6.23      10001: 9.60      11001: 12.94
		00010: 5.23      01010: 6.67      10010: 9.99      11010: 13.31
		00011: 5.32      01011: 7.11      10011: 10.41      11011: 13.70
		00100: 5.42      01100: 7.50      10100: 10.88      11100: 14.11
		00101: 5.52      01101: 7.96      10101: 11.26      11101: 14.56
		00110: 5.62      01110: 8.34      10110: 11.67      11110: 15.04
		00111: 5.85      01111: 8.77      10111: 12.11 <b>11111: 15.41</b>
<b>0x1B, 00, R/W, Color Wheel PWM Voltage(1)</b>		
CW_PWM <7:0>	[7:0]	Least significant 8 bits of 16 bits register (register 0x1B and 0x1C) Average color wheel PWM voltage (V), step size = 76.295 $\mu$ V <b>0x0000 0 V</b> ..... 0xFFFF 5 V
<b>0x1C, 00, R/W, Color Wheel PWM Voltage(2)</b>		
CW_PWM <15:8>	[7:0]	Most significant 8 bits of 16 bits register (register 0x1B and 0x1C) Average color wheel PWM voltage (V), step size = 76.295 $\mu$ V <b>0x0000 0 V</b> ..... 0xFFFF 5 V
<b>0x25, 00, R/W, ILLUM BUCK CONVERTER BANDWIDTH SELECTION</b>		
reserved	[7:4]	
ILLUM_BW_BC1	[3,2]	ILED CONTROL LOOP BANDWIDTH INCREASE (dB) <b>00: 0</b>
		01: 1.9
		10: 4.7
		11: 9.3
ILLUM_BW_BC2	[1,0]	ILED CONTROL LOOP BANDWIDTH INCREASE (dB) <b>00: 0</b>
		01: 1.9
		10: 4.7
		11: 9.3
<b>0x26, 9F, R, Capability register</b>		
LED_AUTO_TURN_OFF_CAP	[7]	0: LED_AUTO_TURN_OFF_CAP disabled <b>1: LED_AUTO_TURN_OFF_CAP enabled</b>
ILLUM_EXT_SWITCH_CAP	[6]	<b>0: No external switch control capability</b> 1: External switch control capability included
CW_CAP	[5]	<b>0: No color wheel capability</b> 1: Color wheel capability included
DMD type	[4]	0: VSP <b>1: TRP</b>
DMD_LDO1_USE	[3]	0: LDO1 not used for DMD, voltage set by user register <b>1: LDO1 used for DMD, voltage set by EEPROM</b>
DMD_LDO2_USE	[2]	0: LDO2 not used for DMD, voltage set by user register <b>1: LDO2 used for DMD, voltage set by EEPROM</b>
DMD_BUCK1_USE	[1]	0: DMD Buck1 disabled <b>1: DMD Buck1 used</b>

**Register Maps (continued)**
**Table 9. Register Map (continued)**

NAME	BITS	DESCRIPTION
DMD_BUCK2_USE	[0]	0: DMD Buck2 disabled 1: <b>DMD Buck2 used</b>
<b>0x27, 00, R, Detailed status register1 (Power good failures for general purpose and illumination blocks)</b>		
BUCK_GP3_PG_FAULT	[7]	<b>0: No fault</b> 1: Focus motor buck power good failure. Does not initiate a fast shutdown.
BUCK_GP1_PG_FAULT	[6]	<b>0: No fault</b> 1: General purpose buck1 power good failure. Does not initiate a fast shutdown.
BUCK_GP2_PG_FAULT	[5]	<b>0: No fault</b> 1: General purpose buck2 power good failure. Does not initiate a fast shutdown.
Reserved	[4]	
ILLUM_BC1_PG_FAULT	[3]	<b>0: No fault</b> 1: Illum buck converter1 power good failure. Does not initiate a fast shutdown.
ILLUM_BC2_PG_FAULT	[2]	<b>0: No fault</b> 1: Illum buck converter2 power good failure. Does not initiate a fast shutdown.
TBD	[1]	<b>Reserved, value always 0</b>
TBD	[0]	<b>Reserved, value always 0</b>
<b>0x28, 00, R, Detailed status register2 (Overvoltage failures for general purpose and illum blocks)</b>		
BUCK_GP3_OV_FAULT	[7]	<b>0: No fault</b> 1: Focus motor buck overvoltage failure. Does not initiate a fast shutdown.
BUCK_GP1_OV_FAULT	[6]	<b>0: No fault</b> 1: General purpose buck1 overvoltage failure. Does not initiate a fast shutdown.
BUCK_GP2_OV_FAULT	[5]	<b>0: No fault</b> 1: General purpose buck2 overvoltage failure. Does not initiate a fast shutdown.
TBD	[4]	<b>Reserved, value always 0</b>
ILLUM_BC1_OV_FAULT	[3]	<b>0: No fault</b> 1: Illum buck converter1 overvoltage failure. Does not initiate a fast shutdown.
ILLUM_BC2_OV_FAULT	[2]	<b>0: No fault</b> 1: Illum buck converter2 overvoltage failure. Does not initiate a fast shutdown.
TBD	[1]	<b>Reserved, value always 0</b>
TBD	[0]	<b>Reserved, value always 0</b>
<b>0x29, 00, R, Detailed status register3 (Power good failure for DMD related blocks)</b>		
TBD	[7]	<b>Reserved, value always 0</b>
DMD_PG_FAULT	[6]	<b>0: No fault</b> 1: VBIAS, VOFS and/or VRST power good failure. Initiates a fast shutdown.
BUCK_DMD1_PG_FAULT	[5]	<b>0: No fault</b> 1: Buck1 (used to create DMD voltages) power good failure. Initiates a fast shutdown.
BUCK_DMD2_PG_FAULT	[4]	<b>0: No fault</b> 1: Buck2 (used to create DMD voltages) power good failure. Initiates a fast shutdown.
TBD	[3]	<b>Reserved, value always 0</b>
TBD	[2]	<b>Reserved, value always 0</b>
LDO_GP1_PG_FAULT / LDO_DMD1_PG_FAULT	[1]	<b>0: No fault</b> 1: LDO1 (used as general purpose or DMD specific LDO) power good failure. Initiates a fast shutdown.
LDO_GP2_PG_FAULT / LDO_DMD2_PG_FAULT	[0]	<b>0: No fault</b> 1: LDO2 (used as general purpose or DMD specific LDO) power good failure. Initiates a fast shutdown.
<b>0x2A, 00, R, Detailed status register4 (Overvoltage failures for DMD related blocks and Color Wheel)</b>		
TBD	[7]	<b>Reserved, value always 0</b>
TBD	[6]	<b>Reserved, value always 0</b>
BUCK_DMD1_OV_FAULT	[5]	<b>0: No fault</b> 1: Buck1 (used to create DMD voltage) overvoltage failure

**Register Maps (continued)**
**Table 9. Register Map (continued)**

NAME	BITS	DESCRIPTION
BUCK_DMD2_OV_FAULT	[4]	<b>0: No fault</b> 1: Buck2 (used to create DMD voltage) overvoltage failure
TBD	[3]	<b>Reserved, value always 0</b>
TBD	[2]	<b>Reserved, value always 0</b>
LDO_GP1_OV_FAULT / LDO_DMD1_OV_FAULT	[1]	<b>0: No fault</b> 1: LDO1 (used as general purpose or DMD specific LDO) overvoltage failure
LDO_GP2_OV_FAULT / LDO_DMD2_OV_FAULT	[0]	<b>0: No fault</b> 1: LDO2 (used as general purpose or DMD specific LDO) overvoltage failure
<b>0x2B, 00, R, Chip ID extension</b>		
CHIP_ID_EXTENTION	[7:0]	ID extension to distinguish between various configuration options.
<b>0x2C, 00, R/W, ILLUM_LED_AUTO_TURN_OFF_DELAY SETTINGS</b>		
Reserved	[7:4]	TBD
ILLUM_LED_AUTO_TURN_OFF_D ELAY	[3:0]	ILLUM_LED_AUTO_TURN_OFF_DELAY (µsec)
		<b>0000: 4.000-4.445</b> 0100: 63.99-71.10      1000: 6.230-7.120      1100: 99.5-113.8
		0001: 8.010-8.900      0101: 128.0-142.2      1001: 12.46-14.24      1101: 199.1-227.6
		0010: 16.02-17.80      0110: 256.0-284.5      1010: 24.89-28.44      1110: 398.3-455.2
		0011: 32.00-35.55      0111: 512.1-569.0      1011: 49.77-56.88      1111: 1024.2-1138.0
<b>0x2E, 00, R/W, User Password</b>		
USER_PASSWORD (0xBABE)	[7:0]	Write Consecutively 0xBA and 0xBE to unlock.
<b>0x2F, 00, R/W, User Protection Register</b>		
TBD	[7:3]	Reserved, value does not matter.
EEPROM_PROGRAM	[2]	<b>0: EEPROM programming disabled</b> 1: Shadow register values programmed to EEPROM
DIRECT_MODE	[1]	<b>0: Direct mode disabled</b> 1: Direct mode enabled (register 0x09 to control switched)
PROTECT_USER_REG	[0]	<b>0: ALL regular USER registers are WRITABLE, except for READ ONLY registers</b> 1: ONLY USER registers 0x02, 0x03, 0x04, 0x05, 0x06, 0x07, 0x08, and 0x09 are WRITABLE
<b>0x30, 00, R/W, User EEPROM Register</b>		
USER_REGISTER1	[7:0]	User EEPROM Register1
<b>0x31, 00, R/W, User EEPROM Register</b>		
USER_REGISTER2	[7:0]	User EEPROM Register2
<b>0x32, 00, R/W, User EEPROM Register</b>		
USER_REGISTER3	[7:0]	User EEPROM Register3
<b>0x33, 00, R/W, User EEPROM Register</b>		
USER_REGISTER4	[7:0]	User EEPROM Register4
<b>0x34, 00, R/W, User EEPROM Register</b>		
USER_REGISTER5	[7:0]	User EEPROM Register5
<b>0x35, 00, R/W, User EEPROM Register</b>		
USER_REGISTER6	[7:0]	User EEPROM Register6

## 8 Application and Implementation

### NOTE

Information in the following applications sections is not part of the TI component specification, and TI does not warrant its accuracy or completeness. TI's customers are responsible for determining suitability of components for their purposes. Customers should validate and test their design implementation to confirm system functionality.

### 8.1 Application Information

In display applications, using the DLPA3000 provides all needed analog functions including all analog power supplies and the RGB LED driver (up to 6 A per LED) to provide a robust and efficient display solution. Each DLP application is derived primarily from the optical architecture of the system and the format of the data coming into the DLPC343x DLP controller chip.

### 8.2 Typical Applications

#### 8.2.1 Typical Application Setup Using DLPA3000

A common application when using DLPA3000 is to use it with a DLP3010 DMD and DLPC3433/DLPC3438 controller for creating a small, ultra-portable projector. The DLPC3433/DLPC3438 in the projector typically receives images from a PC or video player using HDMI or VGA analog, as shown in Figure 27. Card readers and Wi-Fi can also be used to receive images if the appropriate peripheral chips are added. The DLPA3000 provides power supply sequencing and control of the RGB LED currents as required by the application.

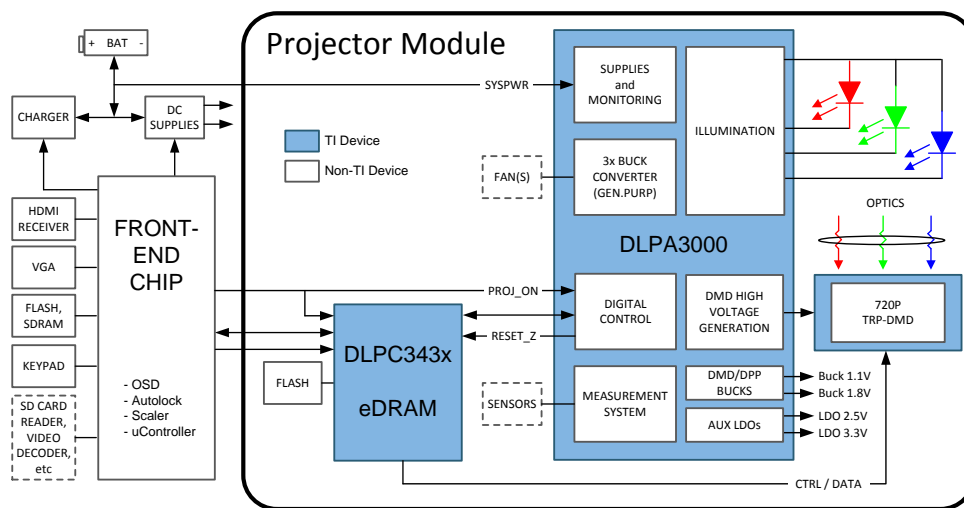

Figure 27. Typical Setup Using DLPA3000

#### 8.2.1.1 Design Requirements

An ultra-portable projector can be created by using a DLP chip set comprised of a DLP3010 (.3 720) DMD, a DLPC3433 or DLPC3438 controller, and the DLPA3000 PMIC/LED Driver. The DLPC3433 or DLPC3438 does the digital image processing, the DLPA3000 provides the needed analog functions for the projector, and DMD is the display device for producing the projected image. In addition to the three DLP chips in the chipset, other chips may be needed. At a minimum, a Flash part is needed to store the software and firmware to control the DLPC3433 or DLPC3438. The illumination light that is applied to the DMD is typically from red, green, and blue LEDs. These are often contained in three separate packages, but sometimes more than one color of LED die may be in the same package to reduce the overall size of the projector. For connecting the DLPC3433 or DLPC3438 to the front-end chip for receiving images, the parallel interface is typically used. While using the parallel interface, I<sup>2</sup>C should be connected to the front-end chip for inputting commands to the DLPC3433 or DLPC3438.

## Typical Applications (continued)

The DLPA3000 has five built-in buck switching regulators to serve as projector system power supplies. Two of the regulators are fixed to 1.1 V and 1.8 V for powering the DLP chipset. The remaining three buck regulators are available for general purpose use and their voltages are programmable. These three programmable regulators can be used to drive variable-speed fans or to power other projector chips, such as the front-end chip. The only power supply needed at the DLPA3000 input is SYSPWR from an external DC power supply or internal battery. The entire projector can be turned on and off by using a single signal called PROJ\_ON. When PROJ\_ON is high, the projector turns on and begins displaying images. When PROJ\_ON is set low, the projector turns off and draws just microamps of current on SYSPWR.

### 8.2.1.2 Detailed Design Procedure

For connecting the DLP3010, DLPC3433 or DLPC3438 and DLPA3000 together, see the reference design schematic. When a circuit board layout is created from this schematic, a very small circuit board is possible. An example small-board layout is included in the reference design database. Layout guidelines should be followed to achieve reliable projector operation. The optical engine that has the LED packages and the DMD mounted to it is typically supplied by an optical OEM who specializes in designing optics for DLP projectors.

### 8.2.1.3 Application Curve

As the LED currents that are driven time-sequentially through the red, green, and blue LEDs are increased, the brightness of the projector increases. This increase is somewhat non-linear, and the curve for typical white-screen lumens changes with LED currents, as shown in Figure 28. For the LED currents shown, it is assumed that the same current amplitude is applied to the red, green, and blue LEDs. The thermal solution used to heatsink the red, green, and blue LEDs can significantly alter the curve shape shown.

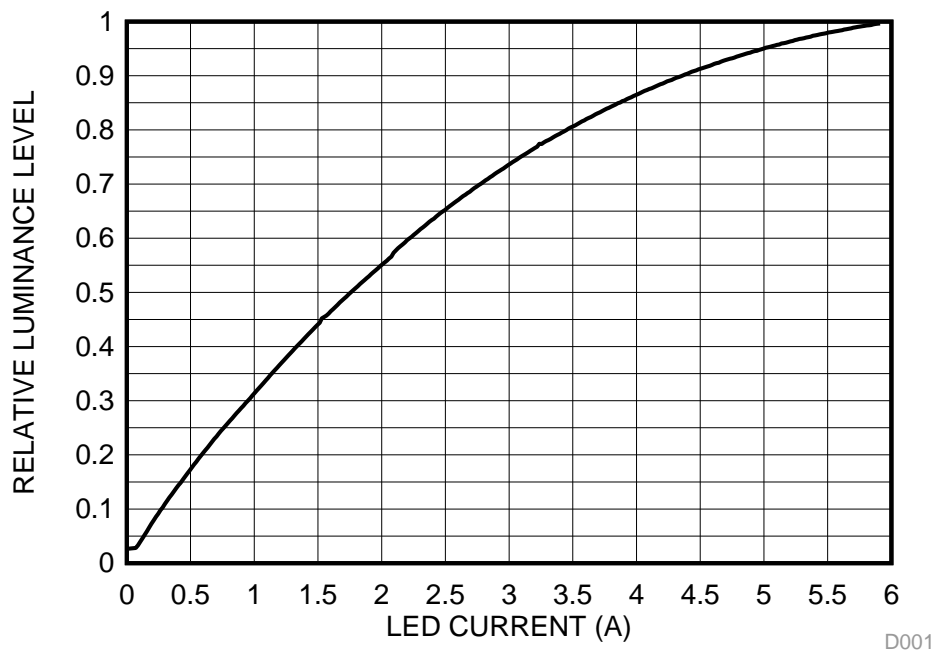

Figure 28. Luminance vs LED Current

D001

Typical Applications (continued)

8.2.2 Typical Application with DLPA3000 Internal Block Diagram

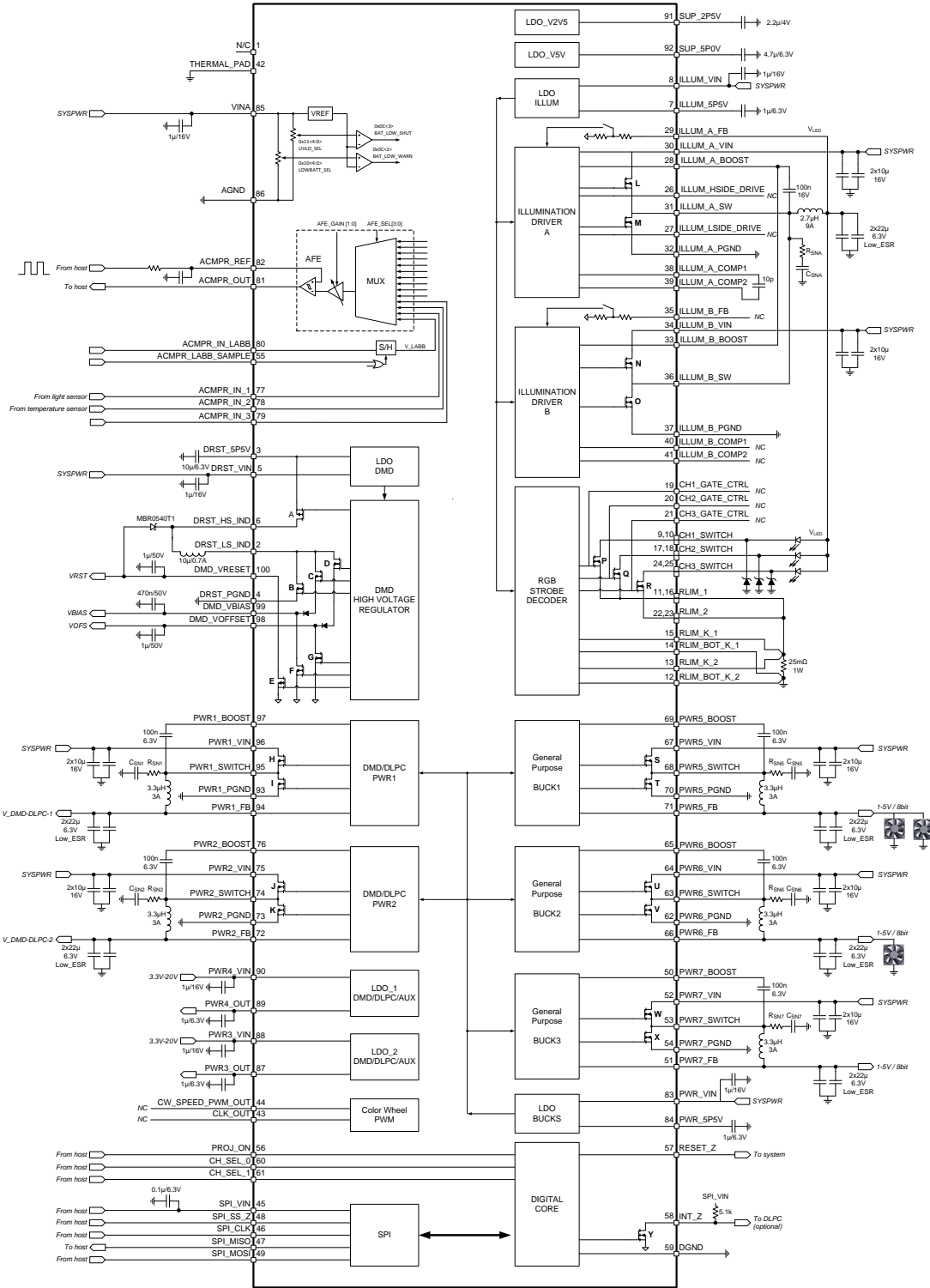

Figure 29. Typical Application: V<sub>IN</sub> = 12 V, I<sub>OUT</sub> = 6 A, LED, Internal FETs

## 9 Power Supply Recommendations

The DLPA3000 is designed to operate from a 6 V to 20 V input voltage supply or battery. To avoid insufficient supply current due to line drop, ringing due to trace inductance at the VIN terminals, or supply peak current limitations, additional bulk capacitance may be required. In the case of ringing that is caused by the interaction with the ceramic input capacitors, an electrolytic or tantalum type capacitor may be needed for damping.

The amount of bulk capacitance required should be evaluated such that the input voltage can remain in spec long enough for a proper fast shutdown to occur for the  $V_{\text{OFFSET}}$ ,  $V_{\text{RESET}}$ , and  $V_{\text{BIAS}}$  supplies. The shutdown begins when the input voltage drops below the programmable UVLO threshold, such as when the external power supply or battery supply is suddenly removed from the system.

## 10 Layout

### 10.1 Layout Guidelines

For switching power supplies, the layout is an important step in the design process, especially when it concerns high-peak currents and high-switching frequencies. If the layout is not carefully done, the regulator could show stability issues and/or EMI problems. Therefore, it is recommended to use wide- and short-traces for high-current paths and for their return power ground paths. The input capacitor, output capacitor, and inductor should be placed as near as possible to the IC. In order to minimize ground noise coupling between different buck converters, it is advised to separate their grounds and connect them together at a central point under the part.

The high currents of the buck converters concentrate around pins  $V_{IN}$ , SWITCH and  $P_{GND}$  (Figure 30). The voltage at the pins  $V_{IN}$ ,  $P_{GND}$ , and FB are DC voltages while the pin SWITCH has a switching voltage between  $V_{IN}$  and  $P_{GND}$ . In case the FET between pins 52 and 53 is closed, the red line indicates the current flow while the blue line indicates the current flow when the FET between pins 53 and 54 is closed. These paths carry the highest currents and must be kept as short as possible.

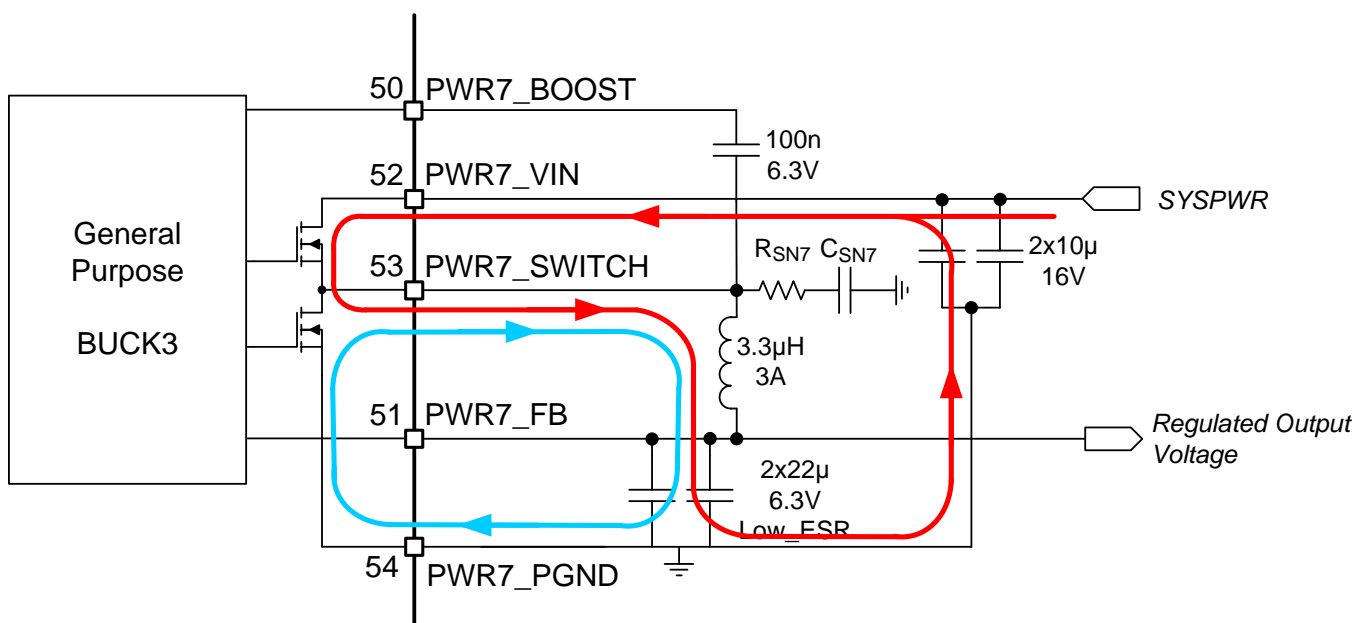

Figure 30. High AC Current Paths in a Buck Converter

The trace to the  $V_{IN}$  pin carries high AC currents. Therefore, the trace should be low-resistive to prevent voltage drop across the trace. Additionally, the decoupling capacitors should be placed as near to the  $V_{IN}$  pin as possible.

The SWITCH pin is connected alternately to the  $V_{IN}$  or GND. This means a square wave voltage is present on the SWITCH pin with an amplitude of  $V_{IN}$  and containing high frequencies. This can lead to EMI problems if not properly handled. To reduce EMI problems, a snubber network (RSN7 & CSN7) is placed at the SWITCH pin to prevent and/or suppress unwanted high-frequency ringing at the moment of switching.

The  $P_{GND}$  pin sinks high current and should be connected to a star ground point such that it does not interfere with other ground connections.

The FB pin is the sense connection for the regulated output voltage, which is a DC voltage; no current is flowing through this pin. The voltage on the FB pin is compared with the internal reference voltage in order to control the loop. The FB connection should be made at the load such that  $I \cdot R$  drop is not affecting the sensed voltage.

### 10.2 Layout Example

As an example of a proper layout, one of the buck converters layout is shown in Figure 31. It shows the routing and placing of the components around the DLPA3000 for optimal performance. The output voltage of the converters used by the DLPA3000 is set through a register. The DLPA3000 uses the feedback pin to compare the output voltage with an internal setpoint.

## Layout Example (continued)

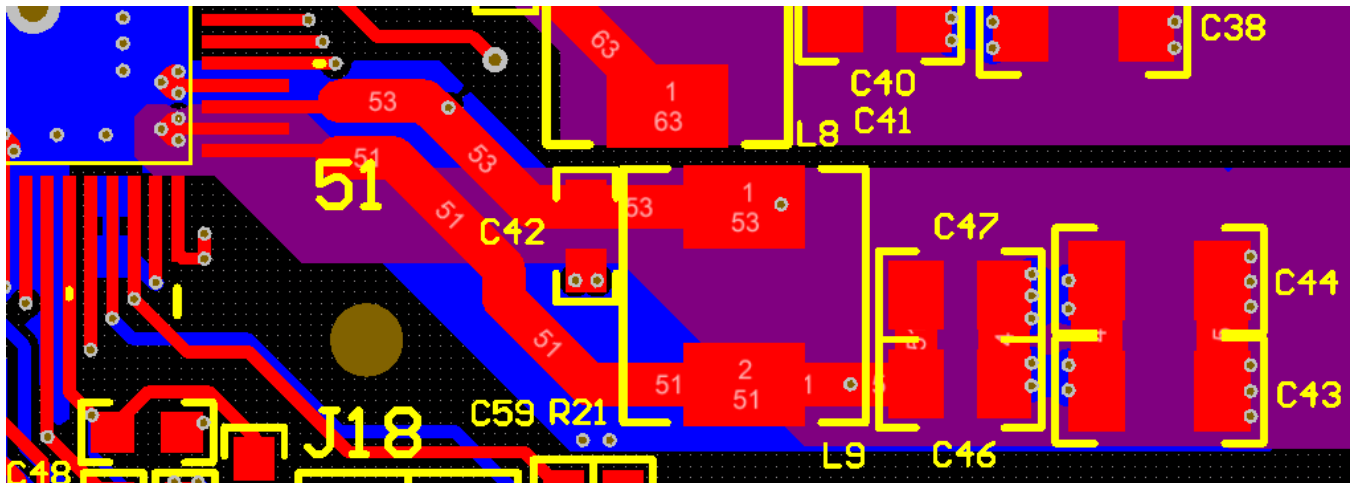

**Figure 31. Practical Layout**

For a proper layout, short traces are required and power grounds should be separated from each other. This avoids ground shift problems, which can occur due to interference of the ground currents of different buck converters. High currents are flowing through the inductor (L9) and the output capacitors (C46, C47). Therefore, it is important to keep the traces to and from inductor and capacitors as short as possible to avoid losses due to trace resistance. It is strongly recommended to use high quality capacitors with a low ESR value to keep the losses in the capacitors as low as possible, and to keep the voltage ripple on the output acceptable.

In order to prevent problems with switching high currents at high frequencies, the layout is very critical and snubber networks are advisable. The switching frequency can vary from several hundreds of kHz to frequencies in the MHz range. Keep in mind that it takes only nanoseconds to switch currents from zero to several amperes, which is equivalent to even much higher frequencies. Those switching moments will cause EMI problems if not properly handled, especially when ringing occurs on the edges, which can have higher amplitude and frequency as the switching voltage itself. To prevent this ringing, the DLPA3000 buck converters all need a snubber network consisting of a resistor and a capacitor in series implemented on the board to reduce this unwanted behavior. In this case, the snubber network is placed on the bottom-side of the PCB (thus not visible here) and connected to the trace of L9 routing to the switch node.

In order to clarify what plays a role when laying out a buck converter, this paragraph explains the connections and placing of the parts around the buck converter connected to the pins 50 through 54. The supply voltage is connected to pin 52, which is laid out on a mid-layer (purple-colored) and is connected to this pin using 3 vias to ensure a stable and low-resistance connection is made. The decoupling is done by capacitor C43 and C44, visible on the bottom-right of [Figure 31](#), and the connection to the supply and the ground layer is done using multiple vias. The ground connection on pin 54 is also done using multiple vias to the ground layer, which is visible as the blue areas in [Figure 31](#). By using different layers, it is possible to create low-resistive paths. Ideally, the ground connection of the output capacitors and the ground connection of the part (pin 54) should be close together. The layout connects both points together using a wide trace on the bottom layer (blue colored area) which is also suitable to bring both connections together. All buck converters in the layout have the same layout structure and use a separated ground trace to their respective ground connection on the part. All these ground connections are connected together on the ground plane below the DLPA3000 itself. [Figure 31](#) shows the position of the converter inductor and its accompanying capacitors (L9 & C46, C47) positioned as near as possible to the pins 51 and 53 using traces as thick as possible. The ground connections of these capacitors is done using multiple vias to the ground layer to ensure a low resistance path.

### 10.3 SPI Connections

The SPI interface consists of several digital lines and the SPI supply. If routing of the interface lines is not done properly, communication errors can occur. It should be prevented that SPI lines can pickup noise and possible interfering sources should be kept away from the interface.

## SPI Connections (continued)

Pickup of noise can be prevented by ensuring that the SPI ground line is routed together with the digital lines as much as possible to the respective pins. The SPI interface should be connected by a separate own ground connection to the DGND of the DLPA3000 (Figure 32). This prevents ground noise between SPI ground references of DLPA3000 and DLPC due to the high current in the system.

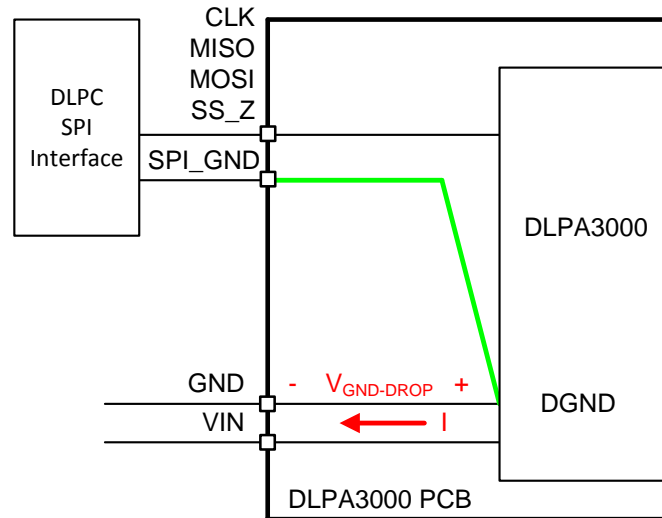

Figure 32. SPI Connections

Interfering sources should be kept away from the interface lines as much as possible. High-current lines, such as neighboring PWR\_7, should especially be routed carefully. If PWR 7 is routed too close to SPI\_CLK, for example, it could lead to false clock pulses and thus communication errors.

### 10.4 $R_{LIM}$ Routing

$R_{LIM}$  is used to sense the LED current. To accurately measure the LED current, the RLIM\_K\_1,2 lines should be connected close to the top-side of measurement resistor  $R_{LIM}$ , while RLIM\_BOT\_K\_1,2 should be connected close to the bottom-side of  $R_{LIM}$ .

The switched LED current is running through  $R_{LIM}$ . Therefore, a low-ohmic ground connection for  $R_{LIM}$  is strongly advised.

### 10.5 LED Connection

Switched large currents are running through the wiring from the DLPA3000 to the LEDs. Therefore, special attention needs to be paid here. Two perspectives apply to the LED-to-DLPA3000 wiring:

1. The resistance of the wiring,  $R_{series}$
2. The inductance of the wiring,  $L_{series}$

The location of the parasitic series impedances are depicted in Figure 33.

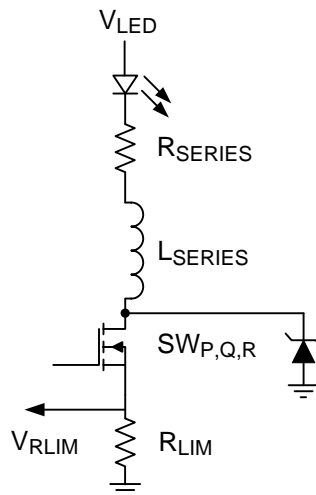
**LED Connection (continued)**

**Figure 33. Parasitic Inductance ( $L_{series}$ ) and Resistance ( $R_{series}$ ) in Series with LED**

Currents up to 6 A can run through the wires connecting the LEDs to the DLPA3000. Some noticeable dissipation can easily be caused. Every 10 m $\Omega$  of series resistances implies for 6 A average LED current a parasitic power dissipation of 0.36 W. This might cause PCB heating, but more importantly, the overall system efficiency is deteriorated.

Additionally, the resistance of the wiring might impact the control dynamics of the LED current. It should be noted that the routing resistance is part of the LED current control loop. The LED current is controlled by  $V_{LED}$ . For a small change in  $V_{LED}$  ( $\Delta V_{LED}$ ) the resulting LED current variation ( $\Delta I_{LED}$ ) is given by the total differential resistance in that path:

$$\Delta I_{LED} = \frac{\Delta V_{LED}}{r_{LED} + R_{series} + R_{on\_SW\_P,Q,R} + R_{LIM}} \quad (10)$$

in which  $r_{LED}$  is the differential resistance of the LED and  $R_{on\_SW\_P,Q,R}$  the on resistance of the strobe decoder switch. In this expression,  $L_{series}$  is ignored since realistic values are usually sufficiently low to cause any noticeable impact on the dynamics.

All the comprising differential resistances are in the range of 25 m $\Omega$  to several 100s m $\Omega$ . Without paying special attention, a series resistance of 100 m $\Omega$  can easily be obtained. It is advised to keep this series resistance sufficiently low (for example, <50 m $\Omega$ ).

The series inductance plays an important role when considering the switched nature of the LED current. While cycling through R, G, and B LEDs, the current through these branches is turned-on and turned-off in short-time duration. Specifically, turning-off is fast. A current of 6 A goes to 0 A in a matter of 50 ns. This implies a voltage spike of about 1 V for every 10 nH of parasitic inductance. It is recommended to minimize the series inductance of the LED wiring by:

- Short wires
- Thick wires / multiple parallel wires
- Small enclosed area of the forward and return current path

If the inductance cannot be made sufficiently low, a zener diode needs to be used to clamp the drain voltage of the RGB switch, such it does not surpass the absolute maximum rating. The clamping voltage needs to be chosen between the maximum expected  $V_{LED}$  and the absolute maximum rating. Take care of sufficient margin of the clamping voltage relative to the mentioned minimum and maximum voltage.

## 10.6 Thermal Considerations

Implementation of integrated circuits in low-profile and fine-pitch surface-mount packages typically requires special attention to power dissipation. Many system-dependent issues such as thermal coupling, airflow, added heat sinks and convection surfaces, and the presence of other heat-generating components affect the power dissipation limits of a given component. In general three basic approaches for enhancing thermal performance can be used; these are listed below:

- Improving the heat sinking capability of the PCB
- Reducing the thermal resistance to the environment of the chip by adding / increasing heat sink capability on top of the package
- Adding or increasing airflow in the system

The DLPA3000 is a device with efficient power converters. Nevertheless, since the power delivered to the LEDs can be quite large (more than 30 W in some cases), the power dissipated in the DLPA3000 device can still be considerable. In order to have proper operation of the DLPA3000, guidance is given below on the thermal dimensioning of the DLPA3000 application.

The target of the dimensioning is to keep the junction temperature below the maximum recommendation of 120°C during operation. In order to determine the junction temperature of the DLPA3000, a summation of all power dissipation terms,  $P_{diss}$ , needs to be made. The junction temperature,  $T_{junction}$ , is then given by:

$$T_{junction} = T_{ambient} + P_{diss} \cdot R_{\theta JA} \quad (11)$$

in which  $T_{ambient}$  is the ambient temperature and  $R_{\theta JA}$  is the thermal resistance from junction to ambient.

Depending on the application of the DLPA3000, the total power dissipation can vary. The main contributors in the DLPA3000 will typically be the:

- Buck converters
- RGB strobe decoder switches
- LDOs

The calculation of the dissipation for these blocks is shown below.

For a buck converter, the dissipated power is given by:

$$P_{diss\_buck} = P_{in} - P_{out} = P_{out} \left( \frac{1}{\eta_{buck}} - 1 \right) \quad (12)$$

where  $\eta_{buck}$  is the efficiency of the buck converter,  $P_{in}$  is the power delivered at the input of the buck converter, and  $P_{out}$  is the power delivered to the load of the buck converter. For buck converter PWR1,2,5,6,7, the efficiency can be determined using the curves in [Figure 22](#).

Similarly, for the buck converter in the illumination block the dissipated power,  $P_{diss\_illum\_buck}$ , can be calculated using the expression for  $P_{diss\_buck}$ . For the illumination block, however, an extra term needs to be added to the dissipation, i.e. the dissipation of the LED switch. So, the dissipation for the illumination block,  $P_{diss\_illum}$ , can be described by:

$$P_{diss\_illum} = P_{out\_LEDs} \left( \frac{1}{\eta_{illum\_buck}} - 1 \right) + I_{LED\_avg}^2 \cdot R_{sw\_PQR} \quad (13)$$

where  $P_{OUT}$  represents the total power supplied to the LEDs,  $I_{LED\_avg}$  is the average LED current, and  $R_{sw\_P,Q,R}$  the on-resistance of the RGB strobe controller switches. It should be noted here that the sense resistor,  $R_{LIM}$ , also carries the average LED current, but is not added to this dissipation term. Since the  $R_{LIM}$  is external to the DLPA3000, it does not contribute to the heating of the DLPA3000, at least not directly, although potentially it does through increasing the ambient temperature. For total system dissipation,  $R_{LIM}$  should of course be included.

These discussed buck converters potentially handle the highest power levels, which is why they need to be power efficient. In contrast, linear regulators, such as LDOs, handle less power. However, since the efficiency of an LDO can be relative low, the related power dissipation can be significant. To calculate the power dissipation of an LDO,  $P_{diss\_LDO}$ , the following equation can be used:

## Thermal Considerations (continued)

$$P_{\text{diss\_LDO}} = (V_{\text{in}} - V_{\text{out}}) \cdot I_{\text{load}} \quad (14)$$

where  $V_{\text{in}}$  is the input supply voltage,  $V_{\text{out}}$  is the output voltage of the LDO, and  $I_{\text{load}}$  is the load current of the LDO. Since the voltage drop over the LDO ( $V_{\text{in}} - V_{\text{out}}$ ) can be relative large, a relatively small load current can yield significant DLPA3000 dissipation. If this situation occurs, one might consider using one of the general purpose bucks to have a more power-efficient (less dissipation) solution.

One LDO, the LDO DMD, needs special attention, since it is used as the power supply of a boost power converter. The boost converter is used to supply the high voltages for the DMD (such as  $V_{\text{BIAS}}$ ,  $V_{\text{OFS}}$ , and  $V_{\text{RST}}$ ). The loading on these lines can be up to  $I_{\text{load,max}} = 10$  mA simultaneously. Thus, the maximum related power level is moderate. Assuming an efficiency on the order of 80% for the boost converter,  $\eta_{\text{boost}}$ , this implies a maximum boost converter dissipation,  $P_{\text{diss\_DMD\_boost,max}}$  of:

$$P_{\text{diss\_DMD\_boost,max}} = I_{\text{load,max}} (V_{\text{BIAS}} + V_{\text{OFS}} + |V_{\text{RST}}|) \cdot \left( \frac{1}{\eta_{\text{boost}}} - 1 \right) \approx 0.1\text{W} \quad (15)$$

In perspective of the dissipation of the illumination buck converter, this is likely negligible. The term that might count to the total power dissipation is  $P_{\text{diss\_LDO\_DMD}}$ . The input current of the DMD boost converter is supplied by this LDO. In case of a high-supply voltage, a non-negligible dissipation term is obtained. The worst-case load current for the LDO is given by:

$$I_{\text{load\_LDO,max}} = \frac{1}{\eta_{\text{boost}}} \frac{(V_{\text{BIAS}} + V_{\text{OFS}} + |V_{\text{RST}}|)}{V_{\text{DRST\_5P5V}}} I_{\text{load,max}} \approx 100\text{mA} \quad (16)$$

where the output voltage of the LDO is  $V_{\text{DRST\_5P5V}} = 5.5$  V.

Thus, the worst-case dissipation of the LDO, can be on the order of 1.5 W for an input supply voltage of 19.5 V. However, this is a worst-case scenario. In most cases, the load current of the LDO DMD is significantly less. It is advised to check this LDO current level for the specific application.

Finally, the DLPA3000 will draw a quiescent current. This quiescent current is relatively independent of the power supply voltage. For the buck converters, the quiescent current is comprised in the efficiency numbers. For the LDOs, a quiescent current on the order of 0.5 mA can be used. For the rest of the DLPA3000 circuitry, not included in the buck converters or LDOs, a quiescent current on the order of 3 mA applies. So, overall, when the power dissipation of the buck converters, illumination block (illumination buck + P,Q,R switches) and the LDOs are summed, a good estimate of the DLPA3000 dissipation,  $P_{\text{diss\_DLPA3000}}$ , is obtained. Given as an equation:

$$P_{\text{diss\_DLPA3000}} = \sum P_{\text{buck\_converters}} + \sum P_{\text{illumination}} + \sum P_{\text{LDOs}} \quad (17)$$

Once this total power dissipation is known, the thermal design can be done. A few examples are given. Assume the total  $P_{\text{diss\_DLPA3000}} = 7.5$  W and the heatsink and airflow is as given in [Thermal Information](#). What is the maximum ambient temperature that can be allowed?

Known parameters:  $T_{\text{junction,max}} = 120$  °C,  $R_{\theta\text{JA}} = 7$  °C/W,  $P_{\text{diss\_DLPA3000}} = 7.5$  W.

Using [Equation 11](#) the maximum ambient temperature can be calculated as:

$$T_{\text{ambient,max}} = T_{\text{junction,max}} - P_{\text{diss}} \cdot R_{\theta\text{JA}} = 120^\circ\text{C} - 7.5\text{W} \cdot 7^\circ\text{C/W} = 67.5^\circ\text{C} \quad (18)$$

In the same way, the junction temperature of the DLPA3000 can be calculated once the dissipated power and the ambient temperature is known. For instance:

$T_{\text{ambient}} = 50$  °C,  $R_{\theta\text{JA}} = 7$  °C/W,  $P_{\text{diss\_DLPA3000}} = 8.5$  W.

For the heat sink configuration and airflow as indicated in [Thermal Information](#), the junction temperature can be calculated to be:

$$T_{\text{junction}} = T_{\text{ambient}} + P_{\text{diss}} \cdot R_{\theta\text{JA}} = 50^\circ\text{C} + 8.5\text{W} \cdot 7^\circ\text{C/W} = 102.5^\circ\text{C} \quad (19)$$

In case the combination of ambient temperature and DLPA3000 power dissipation does not yield an acceptable junction temperature (such as  $<120^\circ\text{C}$ ), two approaches can be used:

1. Using larger heatsink or more airflow to reduce  $R_{\theta\text{JA}}$

## Thermal Considerations (continued)

- Reduce power dissipation in DLPA3000 by for instance not using an internal general purpose buck converter, but an external one. Or lowering maximum LED current.

As a final example, it is shown below how to determine a de-rating of the maximum  $I_{LED}$  in case the junction temperature at  $I_{LED} = 6\text{ A}$  exceeds the maximum allowed temperature. Assume the following parameters:

$P_{buck\_converters} = 1\text{ W}$ ,  $P_{LDOs} = 0.5\text{ W}$ ,  $T_{ambient} = 75^\circ\text{C}$ ,  $R_{\theta JA} = 7^\circ\text{C/W}$ ,  $V_{LED} = 3.5\text{ V}$  and  $T_{junction,max} = 120^\circ\text{C}$ .

In order to find the maximum acceptable LED current, a few steps are required. First, the total maximum allowed dissipation for the DLPA3000 needs to be determined

$$P_{diss,max} = \frac{T_{junction,max} - T_{ambient}}{R_{\theta JA}} = \frac{120^\circ\text{C} - 75^\circ\text{C}}{7^\circ\text{C/W}} = 6.4\text{W} \quad (20)$$

Since the buck converters and LDOs do dissipate in total 2.5 W, for the illumination block the dissipation budget is 4.9 W. The dissipation of the illumination block comprises two terms: the illumination buck converter dissipation and the P,Q,R-switches. Note that the dissipation of  $R_{LIM}$  is not included here since this calculation is about the junction temperature. For overall system dissipation, of course  $R_{LIM}$  should be included.

Information needed to calculate  $I_{LED}$  are the illumination buck converter efficiency and the on-resistance of the P,Q,R-switches.

The efficiency of the converter can be derived from [Figure 14](#). For  $V_{LED} = 3.5\text{ V}$  and  $I_{LED}$  is between 4 A and 6 A, the efficiency is on average 80%. The on resistance of switch P,Q,R is given in the tables and is typically 30 mOhm. Assuming  $V_{LED}$  to be independent of  $I_{LED}$ , the dissipation of the illumination block is given by:

$$P_{diss\_illum} = V_{LED} \cdot I_{LED} \cdot \left( \frac{1}{\eta_{illum\_buck}} - 1 \right) + I_{LED}^2 \cdot R_{on\_sw\_PQR} \quad (21)$$

Rewriting this expression for  $I_{LED}$  yields:

$$I_{LED} = \sqrt{\frac{V_{LED}^2 \left( \frac{1}{\eta_{illum\_buck}} - 1 \right)^2}{4R_{on\_sw\_PQR}^2} + \frac{P_{diss\_illum}}{R_{on\_sw\_PQR}}} - \frac{V_{LED} \left( \frac{1}{\eta_{illum\_buck}} - 1 \right)}{2R_{on\_sw\_PQR}} = 4.8\text{ A} \quad (22)$$

Thus, to meet the maximum junction temperature requirement, the LED current should stay below 4.8 A. Once the maximum current selected, it is advised to redo the thermal calculations based on the LED current. It might be that the assumed efficiency is too high for the first calculated LED current. That would require the calculations to be redone, but now with a better estimate for the efficiency. The same goes for the LED voltage. At lower current, a lower LED voltage is to be expected. That implies a lower power delivered to the LED and less power dissipated in the buck converter.

Once the system is dimensioned and built, the actual junction temperature can be derived from measuring the internal VOTS using the AFE. This is described in [Measurement System](#).

## 11 Device and Documentation Support

### 11.1 Device Support

#### 11.1.1 Device Nomenclature

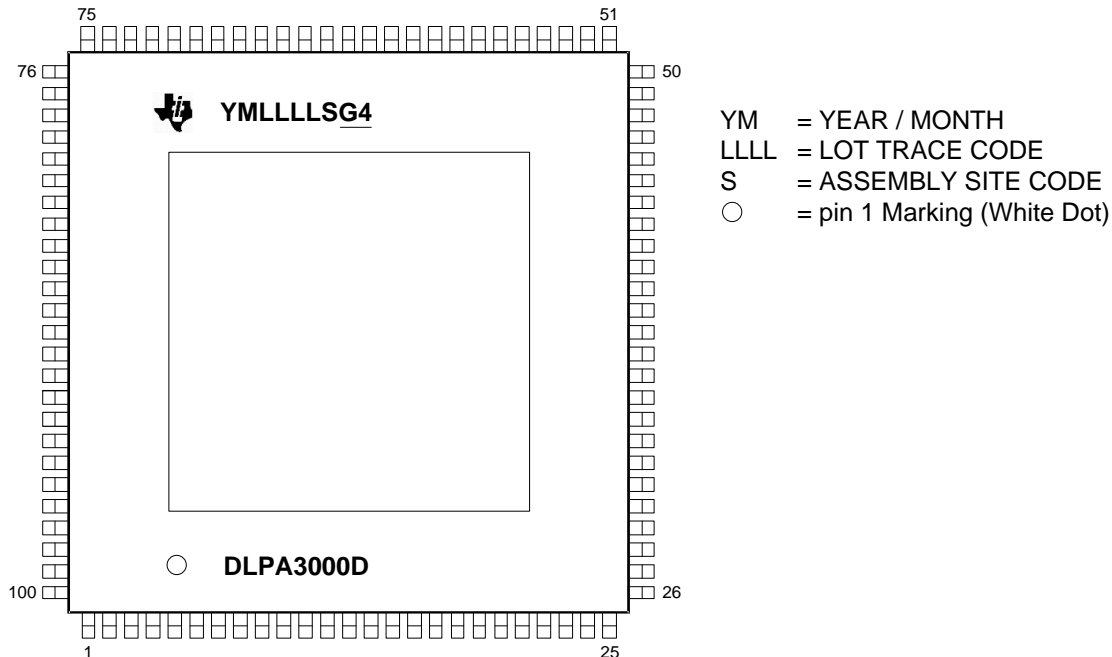

Figure 34. Package Marking DLPA3000 (Top View)

### 11.2 Related Links

The table below lists quick access links. Categories include technical documents, support and community resources, tools and software, and quick access to sample or buy.

Table 10. Related Links

PARTS	PRODUCT FOLDER	SAMPLE & BUY	TECHNICAL DOCUMENTS	TOOLS & SOFTWARE	SUPPORT & COMMUNITY
DLPA3000	<a href="#">Click here</a>	<a href="#">Click here</a>	<a href="#">Click here</a>	<a href="#">Click here</a>	<a href="#">Click here</a>
DLPC3433	<a href="#">Click here</a>	<a href="#">Click here</a>	<a href="#">Click here</a>	<a href="#">Click here</a>	<a href="#">Click here</a>
DLPC3438	<a href="#">Click here</a>	<a href="#">Click here</a>	<a href="#">Click here</a>	<a href="#">Click here</a>	<a href="#">Click here</a>

### 11.3 Community Resources

The following links connect to TI community resources. Linked contents are provided "AS IS" by the respective contributors. They do not constitute TI specifications and do not necessarily reflect TI's views; see TI's [Terms of Use](#).

**TI E2E™ Online Community** *TI's Engineer-to-Engineer (E2E) Community*. Created to foster collaboration among engineers. At e2e.ti.com, you can ask questions, share knowledge, explore ideas and help solve problems with fellow engineers.

**Design Support** *TI's Design Support* Quickly find helpful E2E forums along with design support tools and contact information for technical support.

## 11.4 Trademarks

Pico, E2E are trademarks of Texas Instruments.  
DLP is a registered trademark of Texas Instruments.  
All other trademarks are the property of their respective owners.

## 11.5 Electrostatic Discharge Caution



These devices have limited built-in ESD protection. The leads should be shorted together or the device placed in conductive foam during storage or handling to prevent electrostatic damage to the MOS gates.

## 11.6 Glossary

[SLYZ022](#) — *TI Glossary*.

This glossary lists and explains terms, acronyms, and definitions.

## 12 Mechanical, Packaging, and Orderable Information

The following pages include mechanical, packaging, and orderable information. This information is the most current data available for the designated devices. This data is subject to change without notice and revision of this document. For browser-based versions of this data sheet, refer to the left-hand navigation.

**PACKAGING INFORMATION**

Orderable Device	Status (1)	Package Type	Package Drawing	Pins	Package Qty	Eco Plan (2)	Lead/Ball Finish (6)	MSL Peak Temp (3)	Op Temp (°C)	Device Marking (4/5)	Samples
DLPA3000CPFD	NRND	HTQFP	PFD	100	90	Green (RoHS & no Sb/Br)	CU NIPDAU	Level-2-260C-1 YEAR		DLPA3000C	
DLPA3000CPFDR	NRND	HTQFP	PFD	100	1000	Green (RoHS & no Sb/Br)	CU NIPDAU	Level-2-260C-1 YEAR		DLPA3000C	
DLPA3000DPFD	ACTIVE	HTQFP	PFD	100	90	Green (RoHS & no Sb/Br)	CU NIPDAU	Level-2-260C-1 YEAR		DLPA3000D	Samples
DLPA3000DPFDR	ACTIVE	HTQFP	PFD	100	1000	Green (RoHS & no Sb/Br)	CU NIPDAU	Level-2-260C-1 YEAR		DLPA3000D	Samples

(1) The marketing status values are defined as follows:

**ACTIVE:** Product device recommended for new designs.

**LIFEBUY:** TI has announced that the device will be discontinued, and a lifetime-buy period is in effect.

**NRND:** Not recommended for new designs. Device is in production to support existing customers, but TI does not recommend using this part in a new design.

**PREVIEW:** Device has been announced but is not in production. Samples may or may not be available.

**OBSOLETE:** TI has discontinued the production of the device.

(2) Eco Plan - The planned eco-friendly classification: Pb-Free (RoHS), Pb-Free (RoHS Exempt), or Green (RoHS & no Sb/Br) - please check <http://www.ti.com/productcontent> for the latest availability information and additional product content details.

**TBD:** The Pb-Free/Green conversion plan has not been defined.

**Pb-Free (RoHS):** TI's terms "Lead-Free" or "Pb-Free" mean semiconductor products that are compatible with the current RoHS requirements for all 6 substances, including the requirement that lead not exceed 0.1% by weight in homogeneous materials. Where designed to be soldered at high temperatures, TI Pb-Free products are suitable for use in specified lead-free processes.

**Pb-Free (RoHS Exempt):** This component has a RoHS exemption for either 1) lead-based flip-chip solder bumps used between the die and package, or 2) lead-based die adhesive used between the die and leadframe. The component is otherwise considered Pb-Free (RoHS compatible) as defined above.

**Green (RoHS & no Sb/Br):** TI defines "Green" to mean Pb-Free (RoHS compatible), and free of Bromine (Br) and Antimony (Sb) based flame retardants (Br or Sb do not exceed 0.1% by weight in homogeneous material)

(3) MSL, Peak Temp. - The Moisture Sensitivity Level rating according to the JEDEC industry standard classifications, and peak solder temperature.

(4) There may be additional marking, which relates to the logo, the lot trace code information, or the environmental category on the device.

(5) Multiple Device Markings will be inside parentheses. Only one Device Marking contained in parentheses and separated by a "~" will appear on a device. If a line is indented then it is a continuation of the previous line and the two combined represent the entire Device Marking for that device.

(6) Lead/Ball Finish - Orderable Devices may have multiple material finish options. Finish options are separated by a vertical ruled line. Lead/Ball Finish values may wrap to two lines if the finish value exceeds the maximum column width.

**Important Information and Disclaimer:** The information provided on this page represents TI's knowledge and belief as of the date that it is provided. TI bases its knowledge and belief on information provided by third parties, and makes no representation or warranty as to the accuracy of such information. Efforts are underway to better integrate information from third parties. TI has taken and continues to take reasonable steps to provide representative and accurate information but may not have conducted destructive testing or chemical analysis on incoming materials and chemicals. TI and TI suppliers consider certain information to be proprietary, and thus CAS numbers and other limited information may not be available for release.

In no event shall TI's liability arising out of such information exceed the total purchase price of the TI part(s) at issue in this document sold by TI to Customer on an annual basis.

# MECHANICAL DATA

## PFD (S-PQFP-G100) PowerPAD™ PLASTIC QUAD FLATPACK (DIE DOWN)

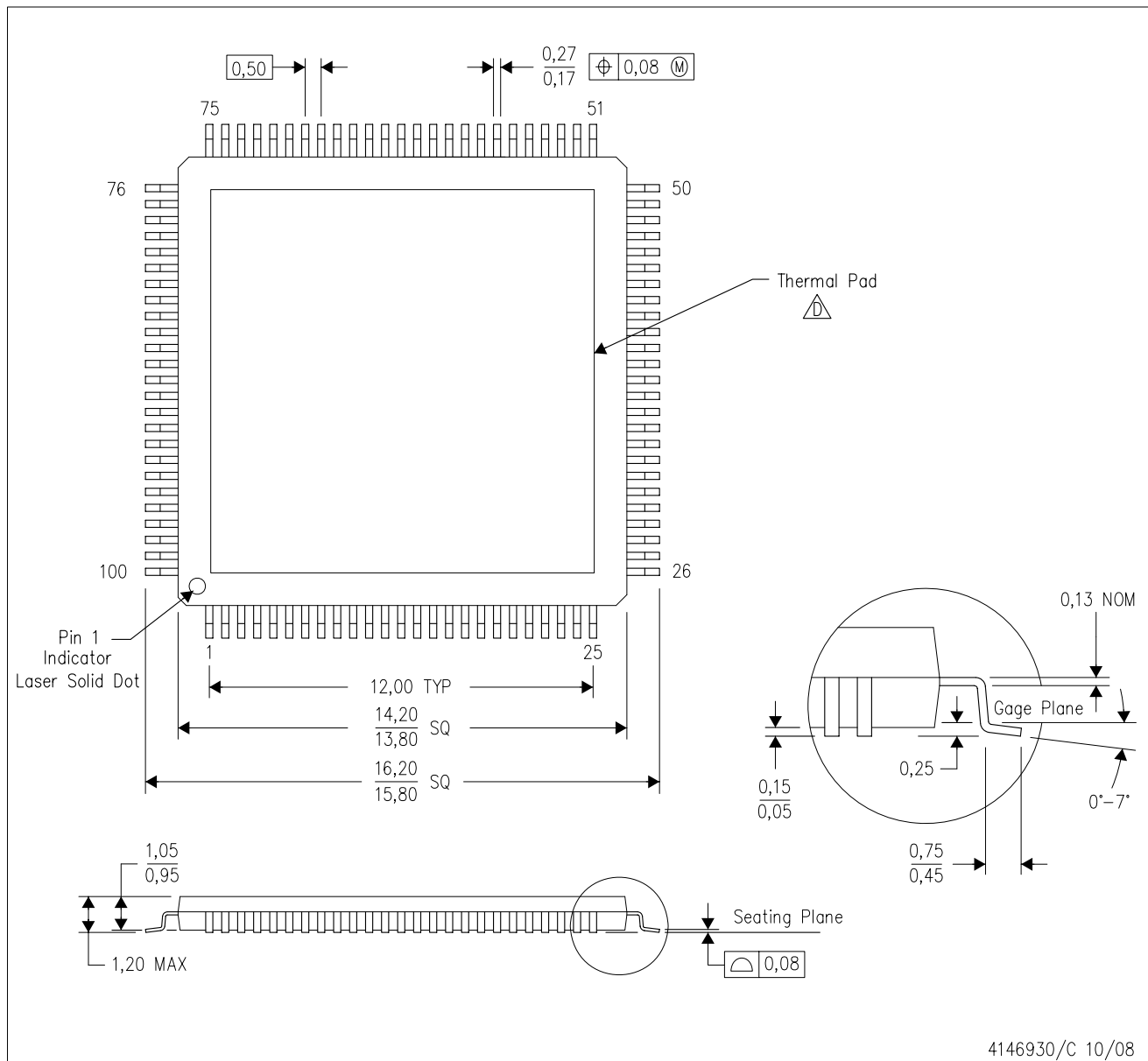

- NOTES:
- All linear dimensions are in millimeters. Dimensioning and tolerancing per ASME Y14.5M-1994.
  - This drawing is subject to change without notice.
  - Body dimensions do not include mold flash or protrusion.
  -  This package is designed to be attached directly to an external heatsink. Refer to Technical Brief, PowerPAD Thermally Enhanced Package, Texas Instruments Literature No. SLMA002 for information regarding recommended board layout. This document is available at [www.ti.com](http://www.ti.com) <<http://www.ti.com>>. See the product data sheet for details regarding the exposed thermal pad dimensions.
  - Falls within JEDEC MS-026

PowerPAD is a trademark of Texas Instruments.

# THERMAL PAD MECHANICAL DATA

PFD (S-PQFP-G100)

PowerPAD™ PLASTIC QUAD FLATPACK

## THERMAL INFORMATION

This PowerPAD™ package incorporates an exposed thermal pad that is designed to be attached directly to an external heatsink. This design optimizes the heat transfer from the integrated circuit (IC).

For additional information on the PowerPAD package and how to take advantage of its heat dissipating abilities, refer to Technical Brief, PowerPAD Thermally Enhanced Package, Texas Instruments Literature No. SLMA002 and Application Brief, PowerPAD Made Easy, Texas Instruments Literature No. SLMA004. Both documents are available at [www.ti.com](http://www.ti.com).

The exposed thermal pad dimensions for this package are shown in the following illustration.

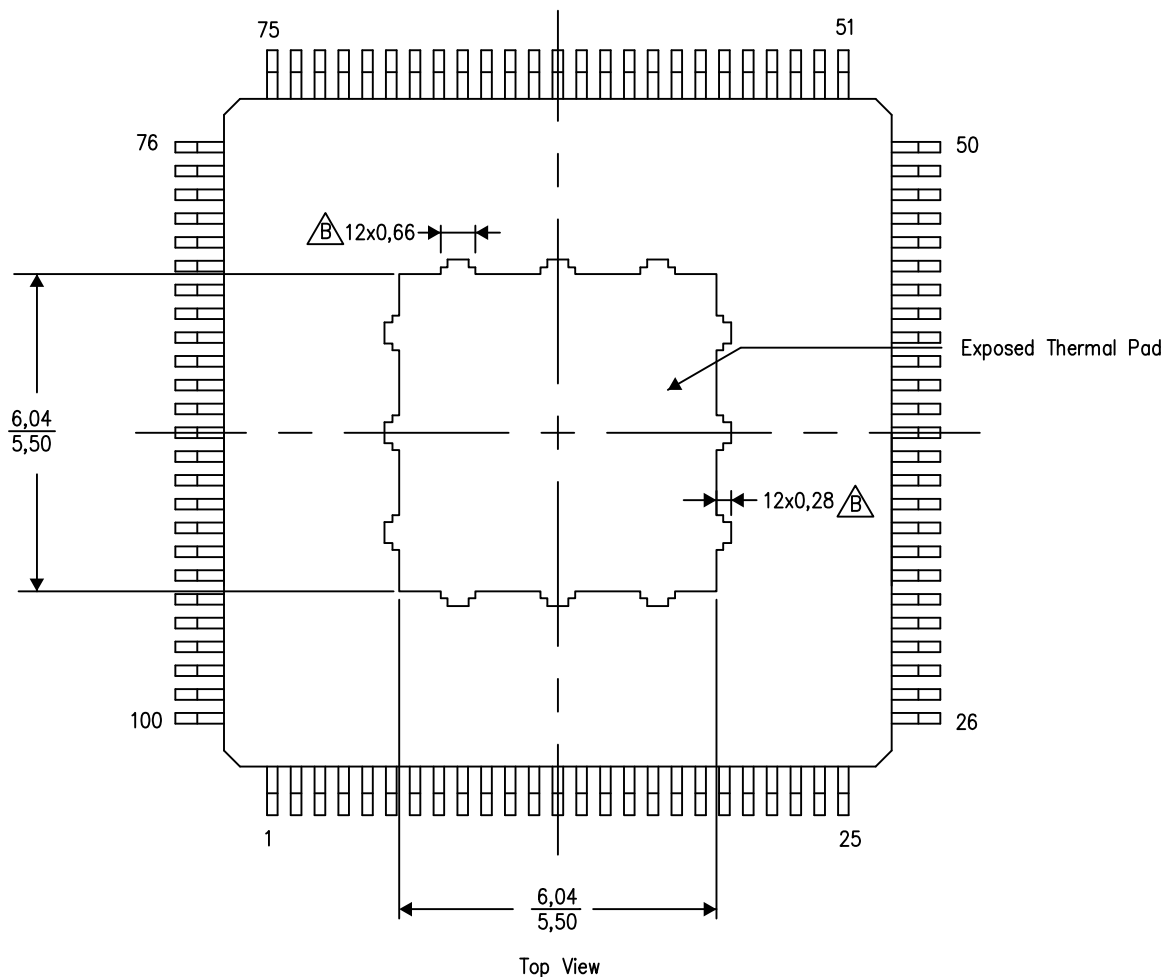

Exposed Thermal Pad Dimensions

4211595-3/B 06/14

NOTE: A. All linear dimensions are in millimeters

 Tie strap features may not be present.

PowerPAD is a trademark of Texas Instruments

PFD (S-PQFP-G100)

PowerPAD™ PLASTIC QUAD FLATPACK

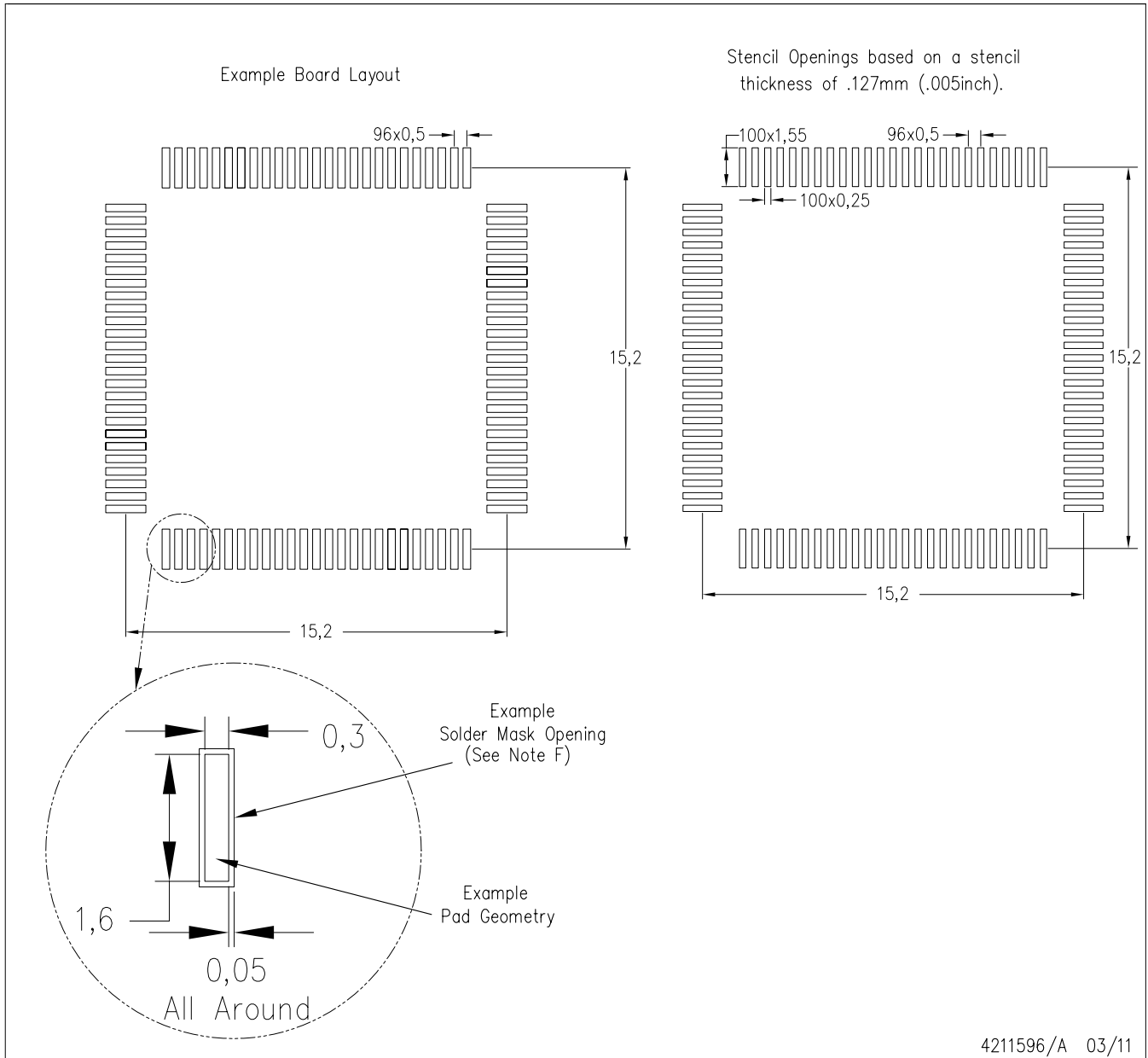

- NOTES:
- A. All linear dimensions are in millimeters.
  - B. This drawing is subject to change without notice.
  - C. Laser cutting apertures with trapezoidal walls and also rounding corners will offer better paste release. Customers should contact their board assembly site for stencil design recommendations. Example stencil design based on a 50% volumetric metal load solder paste. Refer to IPC-7525 for other stencil recommendations.
  - D. Customers should contact their board fabrication site for solder mask tolerances between and around signal pads.

## IMPORTANT NOTICE

Texas Instruments Incorporated and its subsidiaries (TI) reserve the right to make corrections, enhancements, improvements and other changes to its semiconductor products and services per JESD46, latest issue, and to discontinue any product or service per JESD48, latest issue. Buyers should obtain the latest relevant information before placing orders and should verify that such information is current and complete. All semiconductor products (also referred to herein as "components") are sold subject to TI's terms and conditions of sale supplied at the time of order acknowledgment.

TI warrants performance of its components to the specifications applicable at the time of sale, in accordance with the warranty in TI's terms and conditions of sale of semiconductor products. Testing and other quality control techniques are used to the extent TI deems necessary to support this warranty. Except where mandated by applicable law, testing of all parameters of each component is not necessarily performed.

TI assumes no liability for applications assistance or the design of Buyers' products. Buyers are responsible for their products and applications using TI components. To minimize the risks associated with Buyers' products and applications, Buyers should provide adequate design and operating safeguards.

TI does not warrant or represent that any license, either express or implied, is granted under any patent right, copyright, mask work right, or other intellectual property right relating to any combination, machine, or process in which TI components or services are used. Information published by TI regarding third-party products or services does not constitute a license to use such products or services or a warranty or endorsement thereof. Use of such information may require a license from a third party under the patents or other intellectual property of the third party, or a license from TI under the patents or other intellectual property of TI.

Reproduction of significant portions of TI information in TI data books or data sheets is permissible only if reproduction is without alteration and is accompanied by all associated warranties, conditions, limitations, and notices. TI is not responsible or liable for such altered documentation. Information of third parties may be subject to additional restrictions.

Resale of TI components or services with statements different from or beyond the parameters stated by TI for that component or service voids all express and any implied warranties for the associated TI component or service and is an unfair and deceptive business practice. TI is not responsible or liable for any such statements.

Buyer acknowledges and agrees that it is solely responsible for compliance with all legal, regulatory and safety-related requirements concerning its products, and any use of TI components in its applications, notwithstanding any applications-related information or support that may be provided by TI. Buyer represents and agrees that it has all the necessary expertise to create and implement safeguards which anticipate dangerous consequences of failures, monitor failures and their consequences, lessen the likelihood of failures that might cause harm and take appropriate remedial actions. Buyer will fully indemnify TI and its representatives against any damages arising out of the use of any TI components in safety-critical applications.

In some cases, TI components may be promoted specifically to facilitate safety-related applications. With such components, TI's goal is to help enable customers to design and create their own end-product solutions that meet applicable functional safety standards and requirements. Nonetheless, such components are subject to these terms.

No TI components are authorized for use in FDA Class III (or similar life-critical medical equipment) unless authorized officers of the parties have executed a special agreement specifically governing such use.

Only those TI components which TI has specifically designated as military grade or "enhanced plastic" are designed and intended for use in military/aerospace applications or environments. Buyer acknowledges and agrees that any military or aerospace use of TI components which have **not** been so designated is solely at the Buyer's risk, and that Buyer is solely responsible for compliance with all legal and regulatory requirements in connection with such use.

TI has specifically designated certain components as meeting ISO/TS16949 requirements, mainly for automotive use. In any case of use of non-designated products, TI will not be responsible for any failure to meet ISO/TS16949.

### Products

Audio	<a href="http://www.ti.com/audio">www.ti.com/audio</a>
Amplifiers	<a href="http://amplifier.ti.com">amplifier.ti.com</a>
Data Converters	<a href="http://dataconverter.ti.com">dataconverter.ti.com</a>
DLP® Products	<a href="http://www.dlp.com">www.dlp.com</a>
DSP	<a href="http://dsp.ti.com">dsp.ti.com</a>
Clocks and Timers	<a href="http://www.ti.com/clocks">www.ti.com/clocks</a>
Interface	<a href="http://interface.ti.com">interface.ti.com</a>
Logic	<a href="http://logic.ti.com">logic.ti.com</a>
Power Mgmt	<a href="http://power.ti.com">power.ti.com</a>
Microcontrollers	<a href="http://microcontroller.ti.com">microcontroller.ti.com</a>
RFID	<a href="http://www.ti-rfid.com">www.ti-rfid.com</a>
OMAP Applications Processors	<a href="http://www.ti.com/omap">www.ti.com/omap</a>
Wireless Connectivity	<a href="http://www.ti.com/wirelessconnectivity">www.ti.com/wirelessconnectivity</a>

### Applications

Automotive and Transportation	<a href="http://www.ti.com/automotive">www.ti.com/automotive</a>
Communications and Telecom	<a href="http://www.ti.com/communications">www.ti.com/communications</a>
Computers and Peripherals	<a href="http://www.ti.com/computers">www.ti.com/computers</a>
Consumer Electronics	<a href="http://www.ti.com/consumer-apps">www.ti.com/consumer-apps</a>
Energy and Lighting	<a href="http://www.ti.com/energy">www.ti.com/energy</a>
Industrial	<a href="http://www.ti.com/industrial">www.ti.com/industrial</a>
Medical	<a href="http://www.ti.com/medical">www.ti.com/medical</a>
Security	<a href="http://www.ti.com/security">www.ti.com/security</a>
Space, Avionics and Defense	<a href="http://www.ti.com/space-avionics-defense">www.ti.com/space-avionics-defense</a>
Video and Imaging	<a href="http://www.ti.com/video">www.ti.com/video</a>

### TI E2E Community

[e2e.ti.com](http://e2e.ti.com)