

| ATLANTIC VERSION TERMINATOR INTERFACE ADAPTER | PART NUMBER | REVISION | DESCRIPTION | FEED TYPE | APPLICATOR STYLE CONVERSION CHART | | | | | | |
|---|-------------|--------------------------|--------------------------------|--------------------------------|-----------------------------------|-----------------------|-----------|-------------|-----------|-----------|------------------------|
| | | | | | CONVERT TO | PART NUMBERS REQUIRED | | | | | |
| | 2151748-1 | A | FINE CRIMP HEIGHT ADJUST | MECHANICAL | PNEUMATIC FEED | 2119950-1 | 1338685-1 | 5-18022-5 | 2119641-1 | 2119799-1 | 2063440-1 |
| | | | | | SERVO LATCH PLATE | 2119951-1 | - | 8-2151748-5 | 1901094-3 | - | 2168400-6 (QUANTITY 2) |
| | | | | | SMART APPLICATOR | 2161326-1 | - | 8-2151748-4 | - | - | - |
| | 2151748-2 | A | FINE CRIMP HEIGHT ADJUST | PNEUMATIC | MECHANICAL FEED | 2119949-1 | 1338685-1 | 5-18022-5 | 2119653-1 | - | - |
| | | | | | SERVO LATCH PLATE | 2119951-1 | - | 8-2151748-5 | 1901094-3 | - | 2168400-6 (QUANTITY 2) |
| | | | | | SMART APPLICATOR | 2161326-1 | - | 8-2151748-4 | - | - | - |
| | 2151748-5 | A | FINE CRIMP HEIGHT ADJUST | SERVO LATCH PLATE ⁴ | MECHANICAL FEED | 2119949-1 | 1338685-1 | 5-18022-5 | 2119653-1 | - | - |
| PNEUMATIC FEED | | | | | 2119950-1 | 1338685-1 | 5-18022-5 | 2119641-1 | 2119799-1 | 2063440-1 | |
| 2151748-6 | A | NON-CRIMP HEIGHT ADJUST | SERVO LATCH PLATE ⁴ | - | - | - | - | - | - | - | |
| 2151748-7 | A | FINE CRIMP HEIGHT ADJUST | NONE | - | - | - | - | - | - | - | |
| 7-2151748-7 | A | CRIMP TOOLING KIT | - | - | - | - | - | - | - | - | |

| APPLICATOR DATA | | |
|-----------------------------------|----------------|------|
| CRIMP WIRE | SIZE | TYPE |
| WIRE | 2.03 mm [.080] | F |
| INSUL | 2.70 mm [.106] | F |
| APPLICATOR INSTRUCTIONS 408-10389 | | |

| TERMINAL DATA: DELPHI TERMINAL DELPHI CRIMP SPECIFICATION | |
|---|---|
| TERMINAL NAME: TAXI TERM F GT 150 | |
| WIRE STRIP LENGTH 4.55-4.93 mm [.179-.194 IN] | INSULATION DIAMETER RANGE Ø1.70-2.26 mm [.067-.089 IN] |
| TERMINAL APPLICATION SPECIFICATION | DELPHI Rev - |
| TERMINALS APPLIED | |
| TE TERMINAL | DELPHI TERMINAL |
| 1572318-1 | 12191812 |

| WIRE SIZE | CRIMP HEIGHT mm [INCH] | CRIMP HEIGHT REFERENCE SETTING |
|-----------|-------------------------------|--------------------------------|
| 1.00mm2 | 1.40 +/- 0.05 [.055 +/- .002] | 10.1 |
| 0.80mm2 | 1.25 +/- 0.05 [.049 +/- .002] | 11.6 |

- ¹ RECOMMENDED SPARE PARTS
- ² GREASE BEARING SURFACES LIGHTLY
- 3. LUBRICATE DAILY PER THE APPLICATOR INSTRUCTION SHEET SUPPLIED WITH THE APPLICATOR.
- ⁴ APPLICATOR SPECIFIC DATA TO BE ENTERED INTO BLANK MEMORY CHIP AT ASSEMBLY. SEE BELOW FOR PART NUMBER:
MECHANICAL FEED WITH "SMART APPLICATOR" CONVERSION: 8-2151748-4
PNEUMATIC FEED WITH "SMART APPLICATOR" CONVERSION: 8-2151748-4
SERVO FEED WITH "FINE CRIMP HEIGHT ADJUST": 8-2151748-5
SERVO FEED WITH "NON-CRIMP HEIGHT ADJUST": 8-2151748-6
- 5. ADJUSTMENT OF THE STRIPPER MAY BE REQUIRED WHEN MOVING THE APPLICATOR BETWEEN BENCH AND LEADMAKER APPLICATIONS.
- ⁶ APPLY PART NUMBER 1-23419-5 LOCTITE TO THREADS OF ITEM 50,62 & 242. FOR -6 ONLY APPLY PART NUMBER 1-23419-5 LOCTITE TO THREADS OF ITEMS 37,50 & 242.
- ⁷ GREASE THREADS, GROOVE AND O-RING ON ITEMS 35 & 252.
- ⁸ MAGNET, ITEM 166 MUST BE ORIENTED CORRECTLY IN ORDER TO PROPERLY ACTUATE THE COUNTER.
- ⁹ CRIMP HEIGHT REFERENCE SETTING WAS THE SETTING USED WHEN THE APPLICATOR WAS QUALIFIED AT THE FACTORY. ADJUSTMENT MAY BE NECESSARY WHEN RUNNING APPLICATOR IN THE FIELD.
- ¹⁰ SPARE FEED CAM STORAGE LOCATION REFER TO INSTRUCTION SHEET FOR ADDITIONAL INFORMATION.
- ¹¹ TO CONVERT THE APPLICATOR TO A NON-CARRIER CUTTING STYLE, REMOVE ITEM 13 AND ATTACH TO THE LOCATION ON THE BACK SIDE OF THE HOUSING. REFER TO INSTRUCTION SHEET FOR ADDITIONAL INFORMATION.
- ¹² WHEN ASSEMBLING -6 NON-CRIMP HEIGHT ADJUST APPLICATOR USE SHIM PACK 2119957-2 TO ALIGN APPLICATOR'S MAXIMUM WIRE CRIMP HEIGHT AT NORMAL TERMINATOR SHUT HEIGHT

***WARNING**
ON INSTALLATION, SET WIRE DISC, ITEM 40 TO LARGEST WIRE SIZE SETTING. USE OF SETTINGS BELOW MINIMUM REQUIRED CRIMP HEIGHT SETTING WILL CAUSE DAMAGE TO CRIMP TOOLING.

| -77 | -7 | -6 | -5 | -2 | -1 | PART NO | DESCRIPTION | ITEM NO |
|-----|----|----|----|----|----|-----------|-------------------------------------|---------|
| - | - | 1 | - | - | - | 2119957-2 | APPLICATOR SHIM PACK | 260 |
| - | 1 | - | 1 | 1 | 1 | 8-21084-0 | O-RING, .676 ID, .070 DIA. MAT. | 252 |
| - | - | - | - | 1 | - | 2119640-1 | PUSH ROD, AIR FEED | 250 |
| - | - | - | - | - | - | 2079988-1 | BUSHING, LCH5-12, MISUMI | 249 |
| - | - | - | - | - | 1 | 2119641-1 | FEED CAM, AIR FEED | 248 |
| - | 1 | - | 1 | 1 | 1 | 2119798-1 | DETENT PIN | 247 |
| - | 1 | - | 1 | 1 | 1 | 1-22279-3 | SPRING, COMPRESSION | 246 |
| - | - | 1 | - | - | - | 2119758-1 | RAM, AMP STYLE, SIDE FEED, NON-ADJ. | 245 |
| - | 1 | 1 | 1 | 1 | 1 | 2119082-9 | CAM, SNAIL, INSULATION ADJUSTMENT | 244 |

ATLANTIC VERSION
Shown on sheets 1 of 4 & 2 of 4
(Pacific version shown on sheets 3 of 4 & 4 of 4)

| SET UP GAUGE | LOC | DIST | REVISIONS | | | |
|--------------|-----|------|-----------|-----------|----|------|
| 2119599-1 | A | 66 | REV | DATE | BY | APPV |
| | | | 1 | 24AUG2012 | GH | tc |
| | | | 2 | 22OCT2012 | GH | GB |
| | | | A | 16NOV2012 | GH | GB |

| | | | | | | | | | |
|---|-----|-----|-----|-----|-----|-------------|-------------------------------------|-----------------------------------|----|
| - | 1 | 1 | 1 | 1 | 1 | 2079764-1 | WASHER, WAVE SPRING, CREST-TO-CREST | 243 | |
| - | 1 | 1 | 1 | 1 | 1 | 2119083-1 | RETAINER, INSULATION DIAL | 242 | |
| - | 1 | 1 | 1 | 1 | 1 | 7-18023-7 | SCR, SKT HD CAP M3 X 4.0 | 241 | |
| - | - | 2 | 2 | - | - | 2168400-6 | SHCS, LOW HEAD, RoHS, M5 X 16 | 240 | |
| - | - | - | - | - | 1 | 2119580-1 | MECHANICAL FEED ASSEMBLY | 239 | |
| - | - | - | - | - | 1 | 2063440-1 | AIR FEED MODULE | 238 | |
| - | - | 1 | 1 | - | - | 2119740-2 | TAG, IDENTIFICATION | 213 | |
| - | - | 1 | 1 | - | - | 1901094-3 | SPACER, FEEDER | 198 | |
| - | 1 | 1 | 1 | 1 | 1 | 993111-1 | PIN, SLOTTED SPRING 3.0 X 20.0 | 177 | |
| - | 1 | 1 | 1 | 1 | 1 | 8-22280-7 | SPRING, COMPRESSION | 176 | |
| - | 1 | 1 | 1 | 1 | 1 | 1752353-2 | GUIDE PIN, HOLDDOWN | 175 | |
| - | 1 | 1 | 1 | 1 | 1 | 1901680-2 | GUIDE PIN, HOLDDOWN | 174 | |
| - | - | - | - | 2 | - | 21045-3 | RING, RETAIN, EXTERN, 3/16 CRESCENT | 172 | |
| - | 1 | 1 | 1 | 1 | 1 | 994969-1 | MAGNET, RARE EARTH HIGH ENERGY | 166 | |
| - | REF | REF | REF | REF | REF | 994970-2 | COUNTER, MAGNETIC | 164 | |
| - | - | - | - | 1 | - | 240638-1 | SPRING, FEED FINGER | 163 | |
| - | - | - | - | - | 1 | 3-23627-7 | PIN, RETAIN, GRVD, 3/16 X .854 | 137 | |
| - | - | - | - | - | 1 | 2119799-1 | HOLDER, FEED FINGER, AF | 136 | |
| - | - | REF | REF | - | - | SEE NOTE 4 | MEMORY CHIP, PROGRAMMED | 135 | |
| - | - | 1 | 1 | - | - | 1633743-1 | SERVO FEED LATCH ASM | 133 | |
| - | 1 | 1 | 1 | 1 | 1 | 1-18028-2 | WASHER, FLAT, REG M4 | 119 | |
| - | - | REF | REF | - | - | 2119944-1 | FEED FINGER ASSEMBLY, SF | 117 | |
| - | 1 | 1 | 1 | 1 | 1 | 455888-8 | SPACER, CRIMPER | 82 | |
| - | 1 | 1 | 1 | 1 | 1 | 5-547505-2 | SPRING, COMPRESSION | 77 | |
| - | 1 | 1 | 1 | 1 | 1 | 854769-4 | HOLDER, INS | 74 | |
| - | 1 | 1 | 1 | 1 | 1 | 2119956-1 | DOCUMENTATION PACKAGE | 71 | |
| - | 1 | 1 | 1 | 1 | 1 | 2119943-1 | WASHER, SPACER | 69 | |
| - | 1 | - | - | - | 1 | 2119740-1 | TAG, IDENTIFICATION | 67 | |
| - | 2 | 2 | 2 | 2 | 2 | 2168078-1 | SCREW, DRIVE, RH, RoHS | 66 | |
| - | 1 | - | - | 1 | 1 | 2119793-1 | LIMITER, ADJUSTMENT BOLT | 63 | |
| - | 3 | - | 3 | 3 | 3 | 992763-5 | SCR, SET, SOC, CONE POINT, M3 x 4.0 | 62 | |
| - | 1 | 1 | 1 | 1 | 1 | 2079383-4 | SCR, BHSC, RoHS (M4 X 8) | 60 | |
| - | - | - | - | - | 1 | 5-18022-5 | SCR, HEX HD CAP, M4 X 6.0 | 59 | |
| - | 1 | 1 | 1 | 1 | 1 | 21028-2 | PIN, SLOTTED SPRING .062 X .250 | 58 | |
| - | - | - | - | - | 1 | 1338685-1 | PAWL, FEED | 56 | |
| - | 4 | 4 | 4 | 4 | 4 | 2168400-1 | SHCS, LOW HEAD, RoHS, M4 X 12 | 54 | |
| - | 1 | 1 | 1 | 1 | 1 | 1-5018030-0 | NUT, HEX, REG, RoHS, M3.5 | 52 | |
| - | 1 | 1 | 1 | 1 | 1 | 1901681-1 | HOLDDOWN, TERMINAL | 51 | |
| - | 1 | 1 | 1 | 1 | 1 | 1-1752354-8 | STANDOFF, HOLD-DOWN | 50 | |
| - | - | - | - | - | 1 | 2 | 18023-9 | SCR, SKT HD CAP M4 X 6.0 | 49 |
| - | - | - | - | - | - | 1 | 2119652-1 | FEED CAM, PRE FEED | 48 |
| - | - | - | - | - | - | 1 | 2119653-1 | FEED CAM, POST FEED | 47 |
| - | 1 | 1 | 1 | 1 | 1 | 2119656-9 | APPLICATOR BASIC ASSEMBLY, SF | 46 | |
| - | 1 | - | - | - | 1 | 1 | 2119370-1 | RAM, AMP STYLE, SIDE FEED | 44 |
| - | 1 | 1 | 1 | 1 | 1 | 2079383-7 | SCR, BHSC, RoHS (M8 X 25) | 41 | |
| - | 1 | - | - | - | 1 | 1 | 2119645-1 | DISC, NUMBERED FA WIRE ADJUSTMENT | 40 |
| - | 1 | - | - | - | 1 | 1 | 2119957-1 | APPLICATOR SHIM PACK | 39 |
| - | 1 | 1 | 1 | 1 | 1 | 2119644-2 | RAM WASHER, PRECISION | 38 | |
| - | 1 | 1 | 1 | 1 | 1 | 2119085-1 | FA HEAD, ATLANTIC STYLE | 37 | |
| - | 1 | - | - | - | 1 | 1 | 2119092-1 | BOLT, ADJUSTMENT | 35 |
| - | 1 | 1 | 1 | 1 | 1 | 1752356-1 | SUPPORT, TERMINAL | 34 | |
| - | 2 | 2 | 2 | 2 | 2 | 2079383-5 | SCR, BHSC, RoHS (M4 X 20) | 33 | |
| - | 1 | 1 | 1 | 1 | 1 | 2161328-1 | HEX HEAD, FLANGED, M5 x 8mm LONG | 32 | |
| - | 1 | 1 | 1 | 1 | 1 | 1-1320908-0 | SPACER, STRIP GUIDE | 30 | |
| - | 1 | 1 | 1 | 1 | 1 | 2119959-1 | ASSEMBLY, STRIP GUIDE | 29 | |
| - | 1 | 1 | 1 | 1 | 1 | 1-455888-0 | SPACER, CRIMPER | 28 | |
| - | 1 | 1 | 1 | 1 | 1 | 1320928-2 | STRIP GUIDE | 24 | |
| - | 1 | 1 | 1 | 1 | 1 | 2168083-2 | SCR, SKT HD CAP, RoHS, M4 X 8.0 | 21 | |
| - | 1 | 1 | 1 | 1 | 1 | 1-18028-2 | WASHER, FLAT, REG M4 | 20 | |
| - | 1 | 1 | 1 | 1 | 1 | 2119533-1 | STRIPPER, SIDE FEED | 19 | |
| - | 1 | 1 | 1 | 1 | 1 | 2119806-1 | INSERT, SHEAR | 13 | |
| - | 1 | 1 | 1 | 1 | 1 | 3-22280-3 | SPRING, COMPRESSION | 12 | |
| - | 1 | 1 | 1 | 1 | 1 | 1-356885-4 | STOP, SHEAR | 11 | |
| - | 1 | 1 | 1 | 1 | 1 | 2119805-1 | SHEAR HOLDER, FRONT | 10 | |
| - | 1 | 1 | 1 | 1 | 1 | 454276-5 | FLOATING SHEAR, FRONT | 9 | |
| - | 1 | 1 | 1 | 1 | 1 | 1633920-7 | ANVIL, COMBINATION | 8 | |
| - | - | - | - | - | - | - | - | 7 | |
| - | - | - | - | - | - | - | - | 6 | |
| - | 1 | 1 | 1 | 1 | 1 | 2119780-6 | DEPRESSOR, SHEAR | 5 | |
| - | 1 | 1 | 1 | 1 | 1 | 238011-7 | BLOCK, CRIMPER SPACER | 4 | |
| - | 1 | 1 | 1 | 1 | 1 | 5-2119582-6 | CRIMPER, INSULATION F PREMIUM | 3 | |
| - | 1 | 1 | 1 | 1 | 1 | 1-455888-0 | SPACER, CRIMPER | 2 | |
| - | 1 | 1 | 1 | 1 | 1 | 456405-8 | CRIMPER, WIRE PREMIUM | 1 | |

| DIMENSIONS: | | TOLERANCES UNLESS OTHERWISE SPECIFIED: | | DATE | BY | APPV | NAME |
|-------------|-------------|--|------------|--|---------|-------|----------------------------|
| mm | 0 PLC ±.1 | 1 PLC ±.01 | 2 PLC ±.02 | 23AUG2012 | HOFFNER | ELBIN | Ocean Side Feed Applicator |
| | 3 PLC ±.005 | 4 PLC ±.0005 | ANGLES ±.1 | 24 AUG2012 | HOFFNER | ELBIN | |
| MATERIAL | FINISH | WEIGHT | SCALE | Customer Accessible Production Drawing | | | |
| | | | 1:1 | SHEET 1 OF 4 REV A | | | |

| LOC | | DIST | | REVISIONS | | | |
|-----|----|------|-----|-------------|------|-----|------|
| A | 66 | P | LTM | DESCRIPTION | DATE | OWN | APVD |
| | | - | - | SEE SHEET 1 | - | - | - |

FEED TYPE MECHANICAL

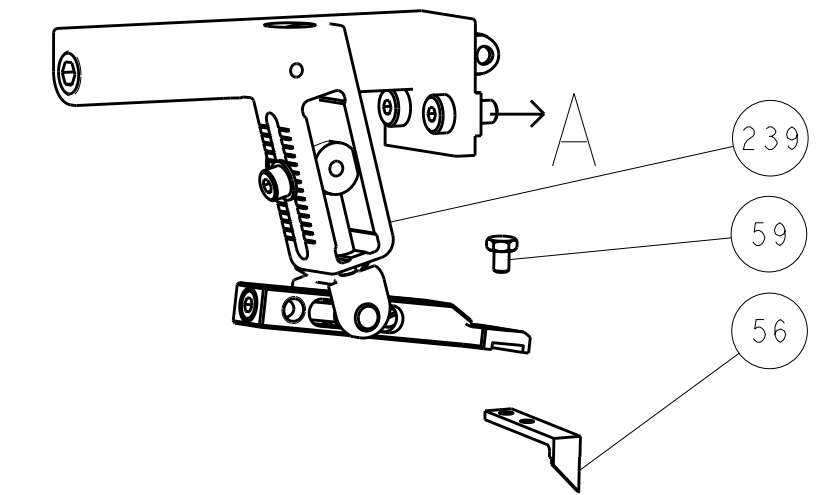

PNEUMATIC

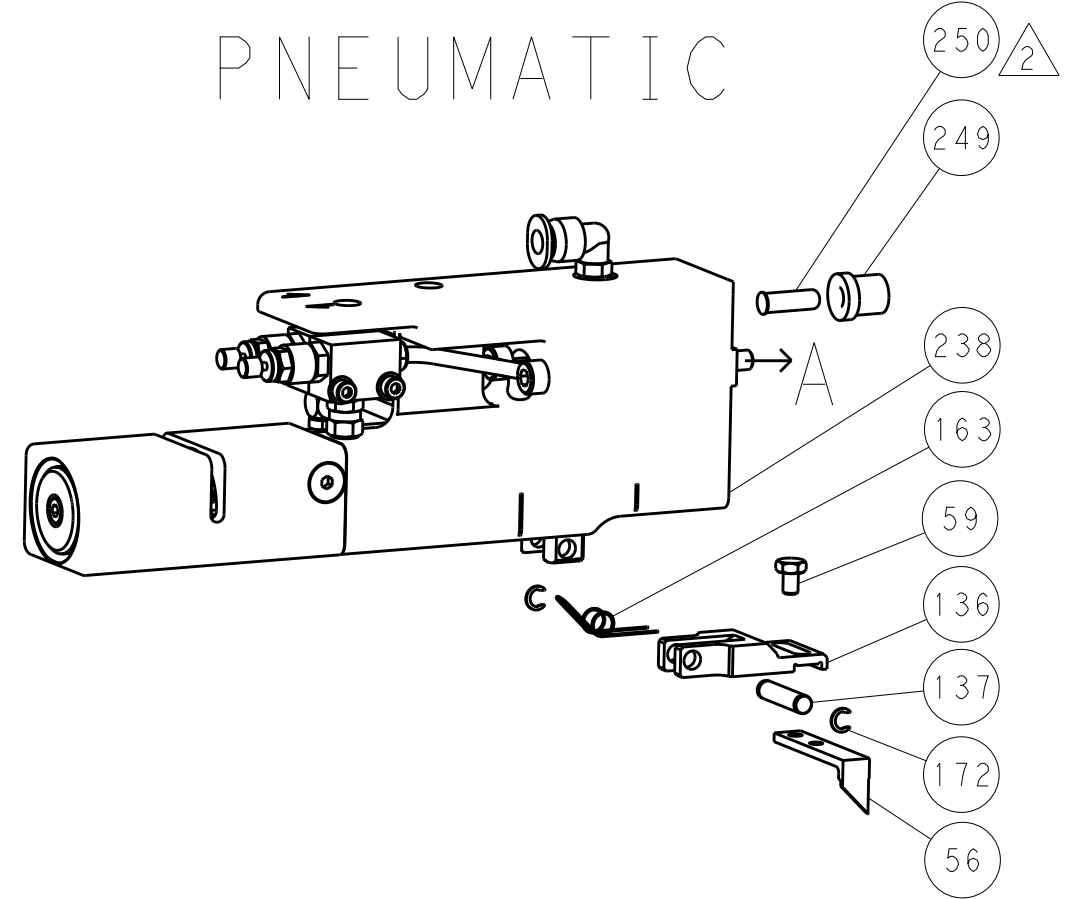

SERVO LATCH PLATE

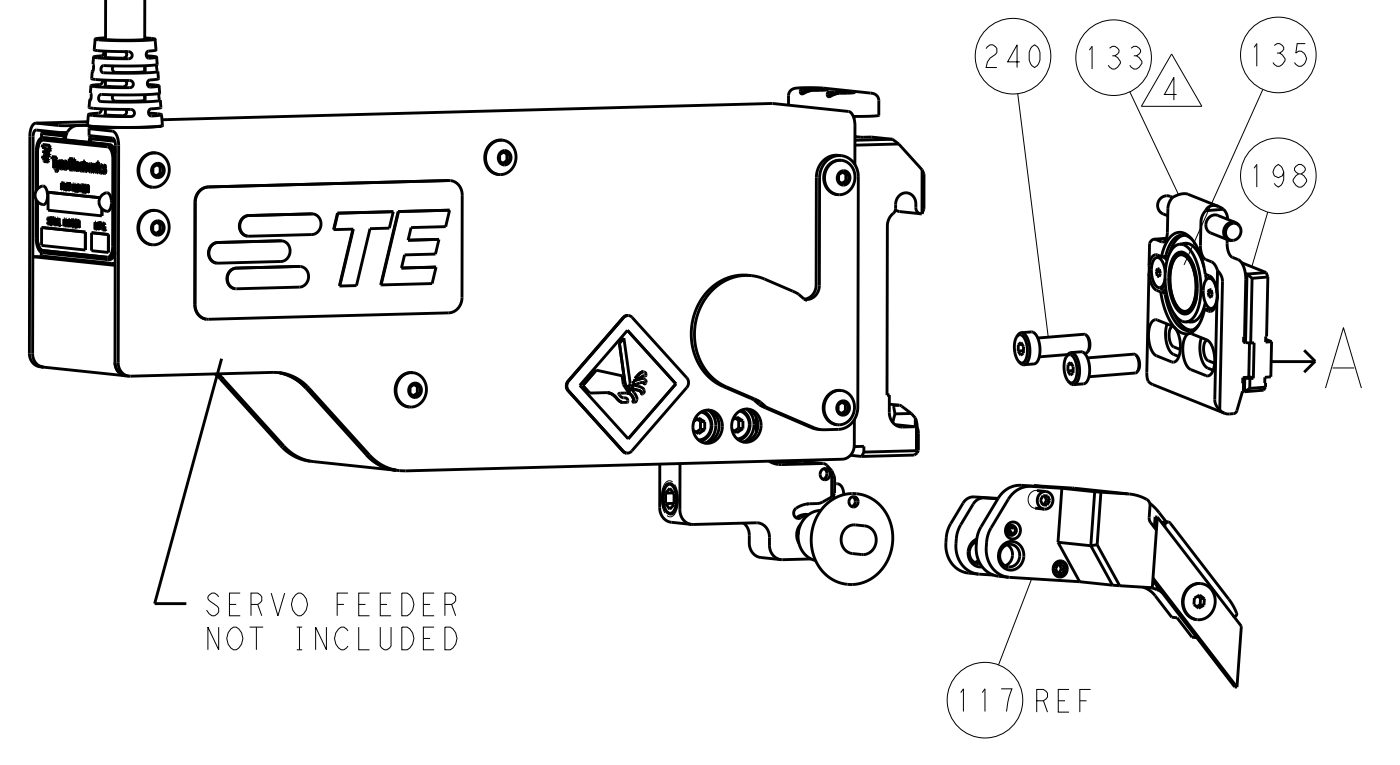

CAM POSITIONS

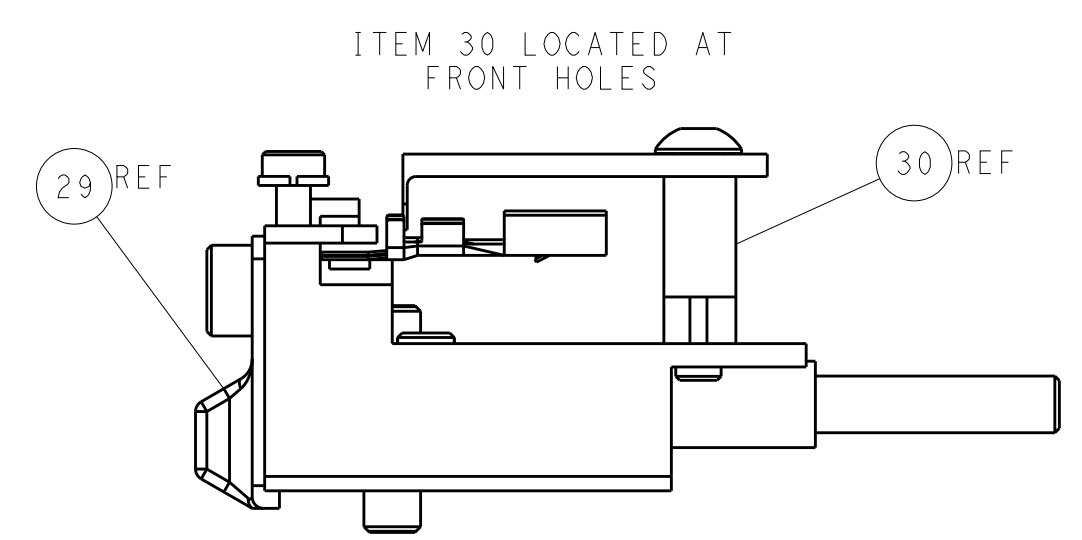
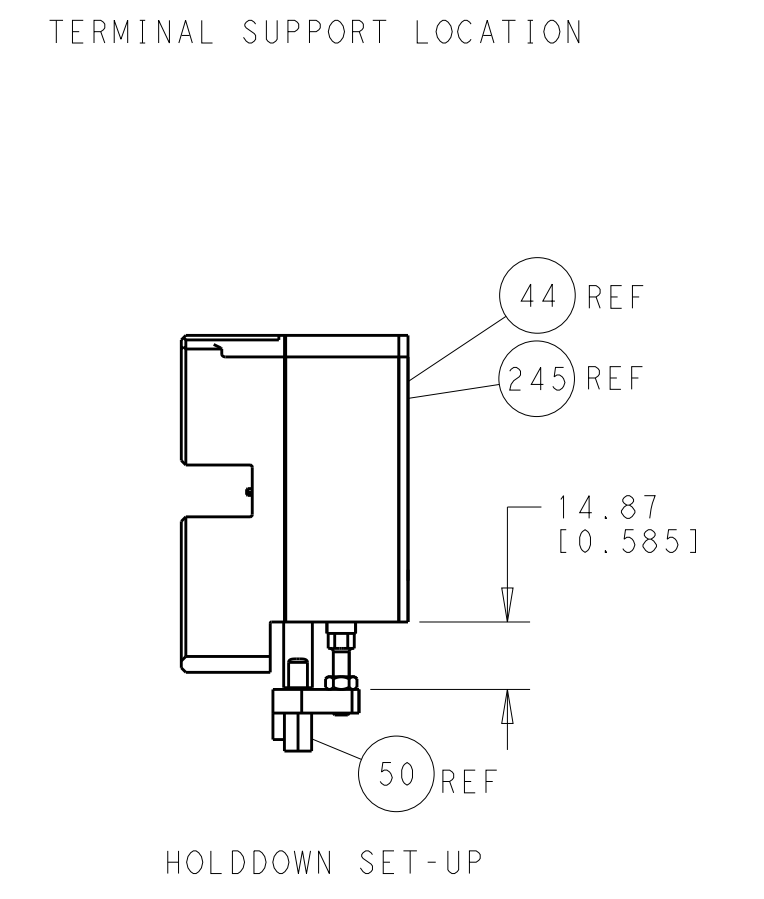
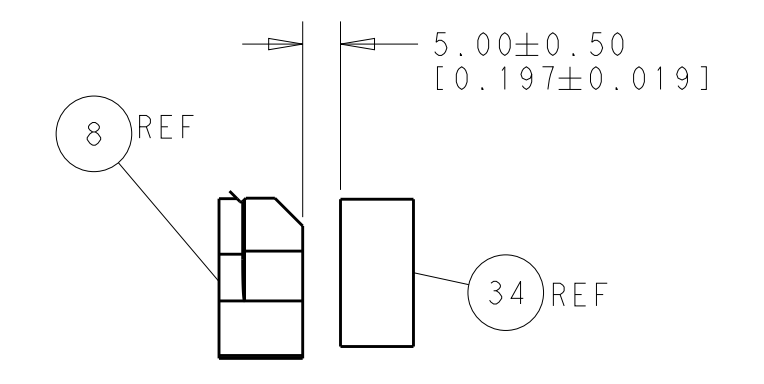
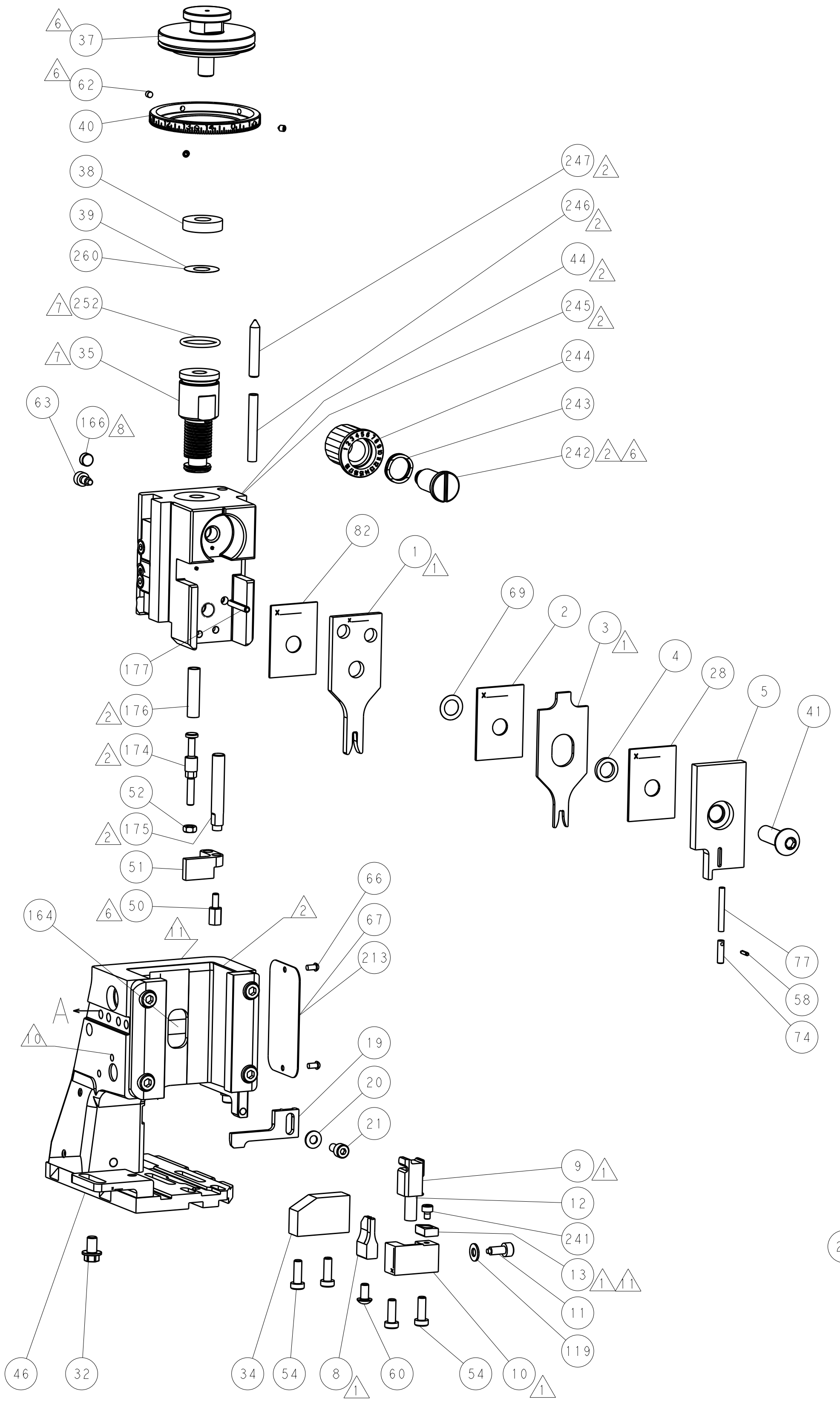
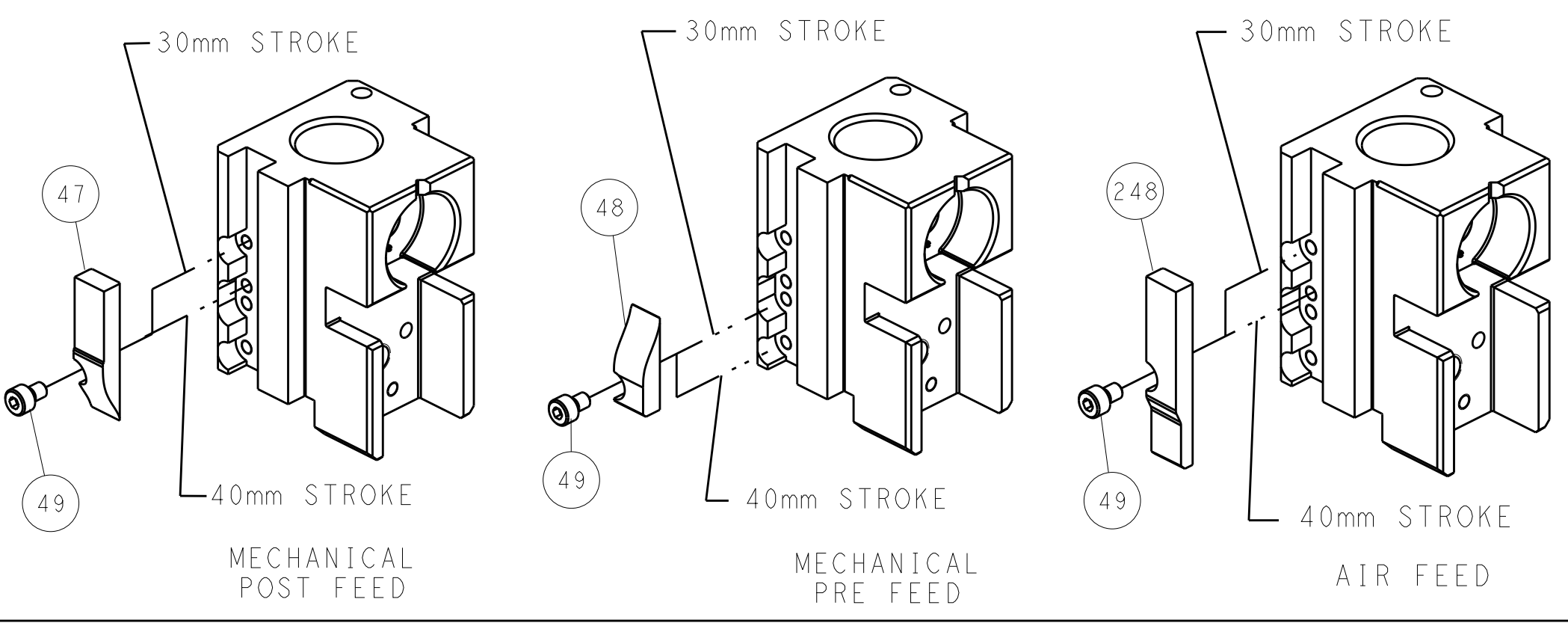

ATLANTIC VERSION
 Shown on sheets 1 of 4 & 2 of 4
 (Pacific version shown on sheets 3 of 4 & 4 of 4)

| | | | | | | | |
|--|------------|--|-------------|------------------------|---------------|----------------------------------|---------------------------|
| DIMENSIONS: | | TOLERANCES UNLESS OTHERWISE SPECIFIED: | | DWN: HOFFNER 23AUG2012 | | TE Connectivity | |
| mm | 0 PLC ±0.1 | 1 PLC ±0.1 | 2 PLC ±0.02 | 3 PLC ±0.005 | 4 PLC ±0.0005 | CHG: TELBIN 24AUG2012 | Harrisburg, PA 17105-3608 |
| MATERIAL: | | FINISH: | | APVD: TELBIN 24AUG2012 | | NAME: Ocean Side Feed Applicator | |
| Customer Accessible Production Drawing | | SCALE: 1:1 | | SHEET 2 of 4 | | REV A | |

| PACIFIC VERSION TERMINATOR INTERFACE ADAPTER | PART NUMBER | REVISION | DESCRIPTION | FEED TYPE | APPLICATOR STYLE CONVERSION CHART | | | | | | |
|--|-------------|----------|--------------------------|--------------------------------|-----------------------------------|-----------------------|-----------|-------------|-----------|-----------|------------------------|
| | | | | | CONVERT TO | PART NUMBERS REQUIRED | | | | | |
| | 2-2151748-1 | A | FINE CRIMP HEIGHT ADJUST | MECHANICAL | PNEUMATIC FEED | 2119950-1 | 1338685-1 | 5-18022-5 | 2119641-2 | 2119799-1 | 2063440-1 |
| | | | | | SERVO LATCH PLATE | 2119951-1 | - | 8-2151748-5 | 1901094-3 | - | 2168400-6 (QUANTITY 2) |
| | | | | | SMART APPLICATOR | 2161326-1 | - | 8-2151748-4 | - | - | - |
| | 2-2151748-2 | A | FINE CRIMP HEIGHT ADJUST | PNEUMATIC | MECHANICAL FEED | 2119949-1 | 1338685-1 | 5-18022-5 | 2119653-2 | - | - |
| | | | | | SERVO LATCH PLATE | 2119951-1 | - | 8-2151748-5 | 1901094-3 | - | 2168400-6 (QUANTITY 2) |
| | | | | | SMART APPLICATOR | 2161326-1 | - | 8-2151748-4 | - | - | - |
| | 2-2151748-5 | A | FINE CRIMP HEIGHT ADJUST | SERVO LATCH PLATE ⁴ | MECHANICAL FEED | 2119949-1 | 1338685-1 | 5-18022-5 | 2119653-2 | - | - |
| | | | | | PNEUMATIC FEED | 2119950-1 | 1338685-1 | 5-18022-5 | 2119641-2 | 2119799-1 | 2063440-1 |
| | 2-2151748-7 | A | FINE CRIMP HEIGHT ADJUST | NONE | - | - | - | - | - | - | - |
| | 7-2151748-7 | A | CRIMP TOOLING KIT | - | - | - | - | - | - | - | - |

| APPLICATOR DATA | | |
|--------------------------------------|----------------|------|
| CRIMP | SIZE | TYPE |
| WIRE | 2.03 mm [.080] | F |
| INSUL | 2.70 mm [.106] | F |
| APPLICATOR INSTRUCTIONS 408-10389 | | |

| TERMINAL DATA: DELPHI TERMINAL DELPHI CRIMP SPECIFICATION | |
|---|---|
| TERMINAL NAME: TAXI TERM F GT 150 | |
| WIRE STRIP LENGTH 4.55-4.93 mm [1.79-.194 IN] | INSULATION DIAMETER RANGE Ø1.70-2.26 mm [.067-.089 IN] |
| TERMINAL APPLICATION SPECIFICATION DELPHI Rev - | |
| TERMINALS APPLIED | |
| TE TERMINAL | DELPHI TERMINAL |
| 1572318-1 | 12191812 |

| WIRE SIZE | CRIMP HEIGHT mm [INCH] | CRIMP HEIGHT REFERENCE SETTING |
|-----------|-------------------------------|--------------------------------|
| 1.00mm2 | 1.40 +/- 0.05 [.055 +/- .002] | 10.1 |
| 0.80mm2 | 1.25 +/- 0.05 [.049 +/- .002] | 11.6 |

- RECOMMENDED SPARE PARTS
- GREASE BEARING SURFACES LIGHTLY
- 3. LUBRICATE DAILY PER THE APPLICATOR INSTRUCTION SHEET SUPPLIED WITH THE APPLICATOR.
- APPLICATOR SPECIFIC DATA TO BE ENTERED INTO BLANK MEMORY CHIP AT ASSEMBLY. SEE BELOW FOR PART NUMBER:
 MECHANICAL FEED WITH "SMART APPLICATOR" CONVERSION: 8-2151748-4
 PNEUMATIC FEED WITH "SMART APPLICATOR" CONVERSION: 8-2151748-4
 SERVO FEED WITH "FINE CRIMP HEIGHT ADJUST": 8-2151748-5
- 5. ADJUSTMENT OF THE STRIPPER MAY BE REQUIRED WHEN MOVING THE APPLICATOR BETWEEN BENCH AND LEADMAKER APPLICATIONS.
- APPLY PART NUMBER 1-23419-5 LOCTITE TO THREADS OF ITEM 50,62 & 242.
- GREASE THREADS, GROOVE AND O-RING ON ITEMS 139 & 152.
- MAGNET MUST BE ORIENTED CORRECTLY IN ORDER TO PROPERLY ACTUATE THE COUNTER.
- CRIMP HEIGHT REFERENCE SETTING WAS THE SETTING USED WHEN THE APPLICATOR WAS QUALIFIED AT THE FACTORY. ADJUSTMENT MAY BE NECESSARY WHEN RUNNING APPLICATOR IN THE FIELD.
- SPARE FEED CAM STORAGE LOCATION REFER TO INSTRUCTION SHEET FOR ADDITIONAL INFORMATION.
- TO CONVERT THE APPLICATOR TO A NON-CARRIER CUTTING STYLE, REMOVE ITEM 13 AND ATTACH TO THE LOCATION ON BACK SIDE OF THE HOUSING. REFER TO INSTRUCTION SHEET FOR ADDITIONAL INFORMATION.

***WARNING**
 ON INSTALLATION, SET WIRE DISC, ITEM 40 TO LARGEST WIRE SIZE SETTING. USE OF SETTINGS BELOW MINIMUM REQUIRED CRIMP HEIGHT SETTING WILL CAUSE DAMAGE TO CRIMP TOOLING.

| | | | | | | | |
|-----|-----|-----|-----|-----|-----------|-------------------------------------|---------|
| - | 1 | 1 | 1 | 1 | 2119782-1 | FINE ADJUST HEAD ASM, PACIFIC STYLE | 251 |
| - | - | - | - | - | 2119640-1 | PUSH ROD, AIR FEED | 250 |
| - | - | - | - | - | 2079988-1 | BUSHING, LCH5-12, MISUMI | 249 |
| - | 1 | 1 | 1 | 1 | 1-22279-3 | SPRING, COMPRESSION | 246 |
| - | 1 | 1 | 1 | 1 | 2119082-9 | CAM, SNAIL, INSULATION ADJUSTMENT | 244 |
| - | 1 | 1 | 1 | 1 | 2079764-1 | WASHER, WAVE SPRING, CREST-TO-CREST | 243 |
| - | 1 | 1 | 1 | 1 | 2119083-1 | RETAINER, INSULATION DIAL | 242 |
| -77 | -27 | -25 | -22 | -21 | PART NO | DESCRIPTION | ITEM NO |

PACIFIC VERSION
 Shown on sheets 3 of 4 & 4 of 4
 (Atlantic version shown on sheets 1 of 4 & 2 of 4)

| SET UP GAUGE | LOC | DIST | REVISIONS | | | |
|--------------|-----|------|-------------|------|----|------|
| 2119599-1 | A | 66 | REV | DATE | BY | APPV |
| - | - | - | SEE SHEET 1 | - | - | - |

| | | | | | | | |
|---|-----|-----|-----|-----|-------------|-------------------------------------|-----|
| - | 1 | 1 | 1 | 1 | 7-18023-7 | SCR, SKT HD CAP M3 X 4.0 | 241 |
| - | - | 2 | - | - | 2168400-6 | SHCS, LOW HEAD, RoHS, M5 X 16 | 240 |
| - | - | - | - | 1 | 2119580-1 | MECHANICAL FEED ASSEMBLY | 239 |
| - | - | - | - | 1 | 2063440-1 | AIR FEED MODULE | 238 |
| - | - | 1 | - | - | 2119740-2 | TAG, IDENTIFICATION | 213 |
| - | - | 1 | - | - | 1901094-3 | SPACER, FEEDER | 198 |
| - | 1 | 1 | 1 | 1 | 993111-1 | PIN, SLOTTED SPRING 3.0 X 20.0 | 177 |
| - | 1 | 1 | 1 | 1 | 8-22280-7 | SPRING, COMPRESSION | 176 |
| - | 1 | 1 | 1 | 1 | 1752353-2 | GUIDE PIN, HOLDDOWN | 175 |
| - | 1 | 1 | 1 | 1 | 1901680-2 | GUIDE PIN, HOLDDOWN | 174 |
| - | - | - | 2 | - | 21045-3 | RING, RETAIN, EXTERN, 3/16 CRESCENT | 172 |
| - | 1 | 1 | 1 | 1 | 994969-1 | MAGNET, RARE EARTH HIGH ENERGY | 166 |
| - | REF | REF | REF | REF | 994970-2 | COUNTER, MAGNETIC | 164 |
| - | - | - | 1 | - | 240638-1 | SPRING, FEED FINGER | 163 |
| - | 1 | 1 | 1 | 1 | 8-21084-1 | O-RING, .801 ID, .070 DIA. MAT. | 152 |
| - | - | - | 1 | - | 2119641-2 | FEED CAM, AIR FEED | 151 |
| - | 1 | 1 | 1 | 1 | 2119798-2 | DETENT PIN | 145 |
| - | 1 | 1 | 1 | 1 | 2079383-8 | SCR, BHSC, RoHS (M4 X 16) | 144 |
| - | 4 | 4 | 4 | 4 | 2168400-5 | SHCS, LOW HEAD, RoHS, M4 X 20 | 143 |
| - | - | - | - | 1 | 2119653-2 | FEED CAM, POST FEED | 142 |
| - | 1 | 1 | 1 | 1 | 1-2119656-0 | APPLICATOR BASIC ASSEMBLY, SF | 141 |
| - | 1 | 1 | 1 | 1 | 2119650-1 | RAM, ASIAN STYLE, SIDE FEED | 140 |
| - | 1 | 1 | 1 | 1 | 2119092-2 | BOLT, ADJUSTMENT | 139 |
| - | - | - | 1 | - | 3-23627-7 | PIN, RETAIN, GRVD, 3/16 X .854 | 137 |
| - | - | - | 1 | - | 2119799-1 | HOLDER, FEED FINGER, AF | 136 |
| - | - | REF | - | - | SEE NOTE 4 | MEMORY CHIP, PROGRAMMED | 135 |
| - | - | 1 | - | - | 1633743-1 | SERVO FEED LATCH ASM | 133 |
| - | 1 | 1 | 1 | 1 | 1-18028-2 | WASHER, FLAT, REG M4 | 119 |
| - | - | REF | - | - | 2119944-1 | FEED FINGER ASSEMBLY, SF | 117 |
| - | 1 | 1 | 1 | 1 | 455888-8 | SPACER, CRIMPER | 82 |
| - | 1 | 1 | 1 | 1 | 5-547505-2 | SPRING, COMPRESSION | 77 |
| - | 1 | 1 | 1 | 1 | 854769-4 | HOLDER, INS | 74 |
| - | 1 | 1 | 1 | 1 | 2119956-1 | DOCUMENTATION PACKAGE | 71 |
| - | 1 | 1 | 1 | 1 | 2119943-1 | WASHER, SPACER | 69 |
| - | 1 | - | 1 | 1 | 2119740-1 | TAG, IDENTIFICATION | 67 |
| - | 2 | 2 | 2 | 2 | 2168078-1 | SCREW, DRIVE, RH, RoHS | 66 |
| - | 1 | 1 | 1 | 1 | 2119793-1 | LIMITER, ADJUSTMENT BOLT | 63 |
| - | 3 | 3 | 3 | 3 | 992763-5 | SCR, SET, SOC, CONE POINT, M3 X 4.0 | 62 |
| - | - | - | 1 | 1 | 5-18022-5 | SCR, HEX HD CAP, M4 X 6.0 | 59 |
| - | 1 | 1 | 1 | 1 | 21028-2 | PIN, SLOTTED SPRING .062 X .250 | 58 |
| - | - | - | 1 | 1 | 1338685-1 | PAWL, FEED | 56 |
| - | 1 | 1 | 1 | 1 | 1-5018030-0 | NUT, HEX, REG, RoHS, M3.5 | 52 |
| - | 1 | 1 | 1 | 1 | 1901681-1 | HOLDDOWN, TERMINAL | 51 |
| - | 1 | 1 | 1 | 1 | 1-1752354-8 | STANDOFF, HOLD-DOWN | 50 |
| - | - | - | 1 | 2 | 18023-9 | SCR, SKT HD CAP M4 X 6.0 | 49 |
| - | - | - | - | 1 | 2119652-1 | FEED CAM, PRE FEED | 48 |
| - | 1 | 1 | 1 | 1 | 2079383-7 | SCR, BHSC, RoHS (M8 X 25) | 41 |
| - | 1 | 1 | 1 | 1 | 2119645-1 | DISC, NUMBERED FA WIRE ADJUSTMENT | 40 |
| - | 1 | 1 | 1 | 1 | 2119957-1 | APPLICATOR SHIM PACK | 39 |
| - | 1 | 1 | 1 | 1 | 2119644-2 | RAM WASHER, PRECISION | 38 |
| - | 1 | 1 | 1 | 1 | 1752356-1 | SUPPORT, TERMINAL | 34 |
| - | 2 | 2 | 2 | 2 | 2079383-5 | SCR, BHSC, RoHS (M4 X 20) | 33 |
| - | 1 | 1 | 1 | 1 | 2161328-1 | HEX HEAD, FLANGED, M5 X 8mm LONG | 32 |
| - | 1 | 1 | 1 | 1 | 1-1320908-0 | SPACER, STRIP GUIDE | 30 |
| - | 1 | 1 | 1 | 1 | 2119959-1 | ASSEMBLY, STRIP GUIDE | 29 |
| - | 1 | 1 | 1 | 1 | 1-455888-0 | SPACER, CRIMPER | 28 |
| - | 1 | 1 | 1 | 1 | 1320928-2 | STRIP GUIDE | 24 |
| - | 1 | 1 | 1 | 1 | 2168083-2 | SCR, SKT HD CAP, RoHS, M4 X 8.0 | 21 |
| - | 1 | 1 | 1 | 1 | 1-18028-2 | WASHER, FLAT, REG M4 | 20 |
| - | 1 | 1 | 1 | 1 | 2119533-1 | STRIPPER, SIDE FEED | 19 |
| - | 1 | 1 | 1 | 1 | 2119806-1 | INSERT, SHEAR | 13 |
| - | 1 | 1 | 1 | 1 | 3-22280-3 | SPRING, COMPRESSION | 12 |
| - | 1 | 1 | 1 | 1 | 1-356885-4 | STOP, SHEAR | 11 |
| - | 1 | 1 | 1 | 1 | 2119805-1 | SHEAR HOLDER, FRONT | 10 |
| - | 1 | 1 | 1 | 1 | 454276-5 | FLOATING SHEAR, FRONT | 9 |
| - | 1 | 1 | 1 | 1 | 1633920-7 | ANVIL, COMBINATION | 8 |
| - | - | - | - | - | - | - | 7 |
| - | - | - | - | - | - | - | 6 |
| - | 1 | 1 | 1 | 1 | 2119780-6 | DEPRESSOR, SHEAR | 5 |
| - | 1 | 1 | 1 | 1 | 238011-7 | BLOCK, CRIMPER SPACER | 4 |
| - | 1 | 1 | 1 | 1 | 5-2119582-6 | CRIMPER, INSULATION F PREMIUM | 3 |
| - | 1 | 1 | 1 | 1 | 1-455888-0 | SPACER, CRIMPER | 2 |
| - | 1 | 1 | 1 | 1 | 456405-8 | CRIMPER, WIRE PREMIUM | 1 |

| DIMENSIONS: | | TOLERANCES UNLESS OTHERWISE SPECIFIED: | | DRAWING NO | |
|-------------|---------------|--|------------|-------------|---------------|
| mm | 0 PLC ±.1 | 1 PLC ±0.1 | 2 PLC ±0.2 | 3 PLC ±0.05 | 4 PLC ±0.0005 |
| | ANGLES ±.0005 | FINISH | | | |
| MATERIAL | | FINISH | | | |

| | | | |
|------|-------------|-----|---------|
| DATE | 23 AUG 2012 | CHK | HOFFNER |
| DATE | 24 AUG 2012 | CHK | ELBIN |
| DATE | 24 AUG 2012 | CHK | ELBIN |
| DATE | 24 AUG 2012 | CHK | ELBIN |

| | | |
|---------------|----------------------------|--------------|
| NAME | Ocean Side Feed Applicator | |
| SIZE | CAGE CODE | DRAWING NO |
| A1 | 00779 | 2151748 |
| RESTRICTED TO | SCALE | SHEET 3 OF 4 |
| | 1:1 | REV A |

| LOC | DIST | REV | DATE | BY | APPV |
|-----|------|-------------|------|----|------|
| A | 66 | | | | |
| | | REVISIONS | | | |
| | | DESCRIPTION | DATE | BY | APPV |
| | | SEE SHEET 1 | | | |

FEED TYPE MECHANICAL

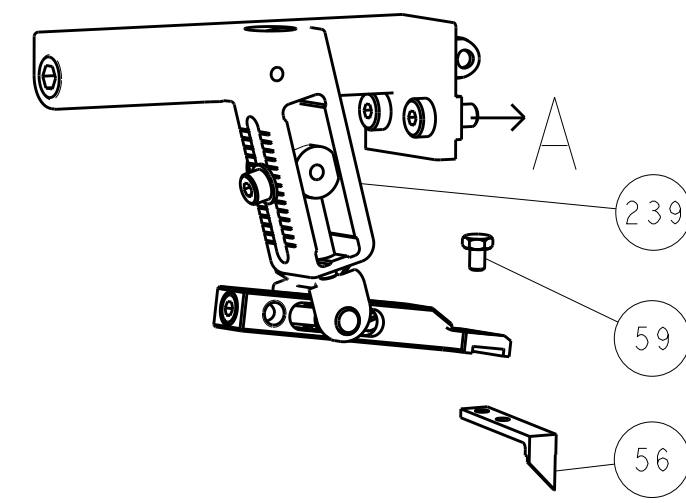

PNEUMATIC

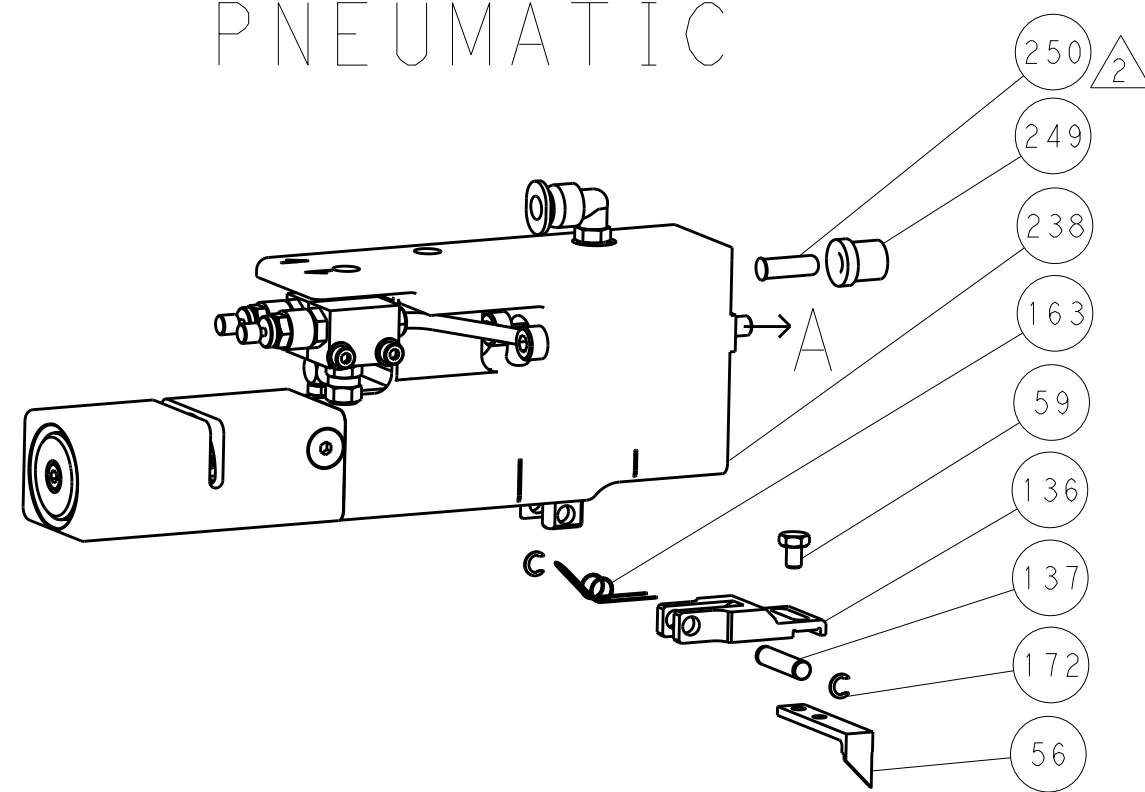

SERVO LATCH PLATE

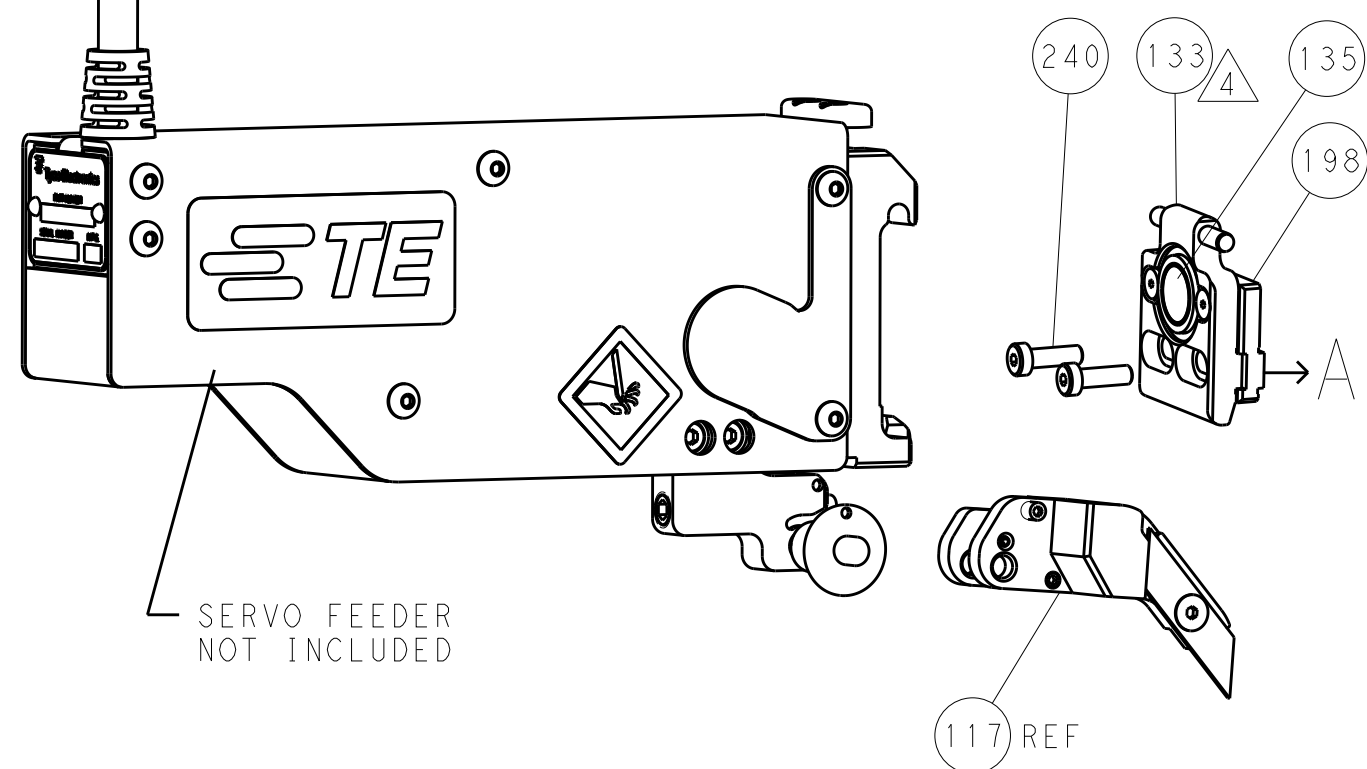

CAM POSITIONS

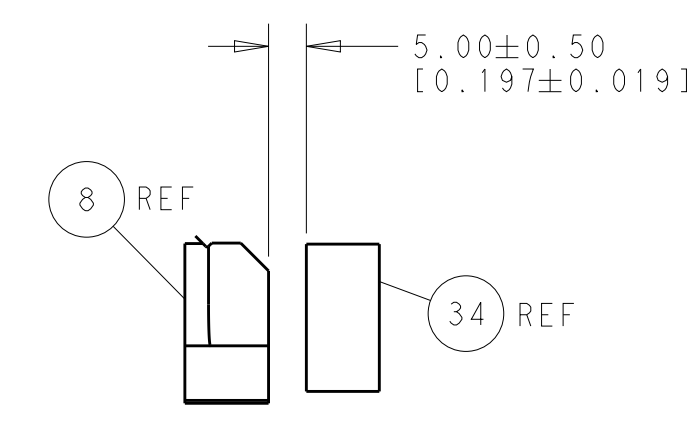
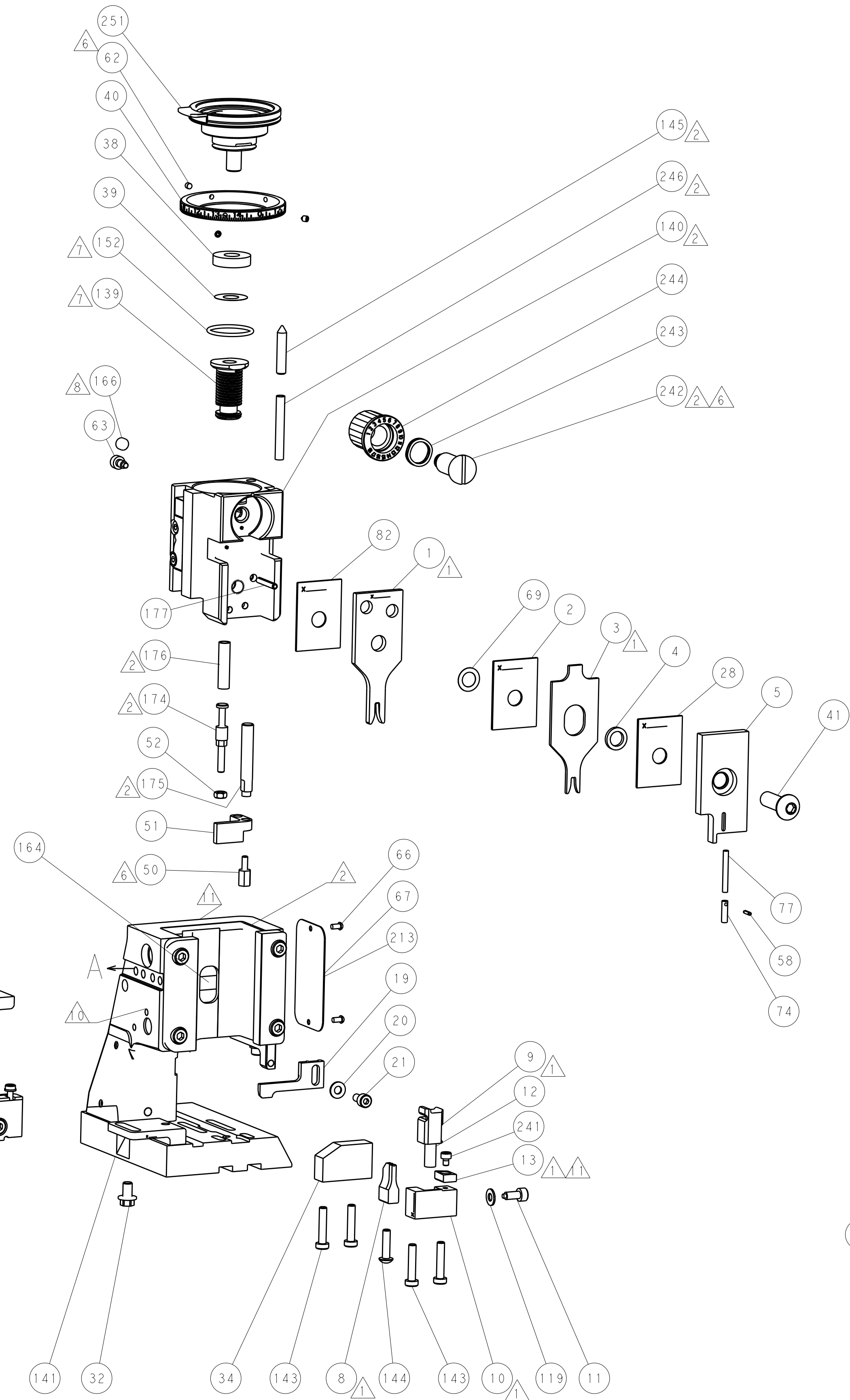
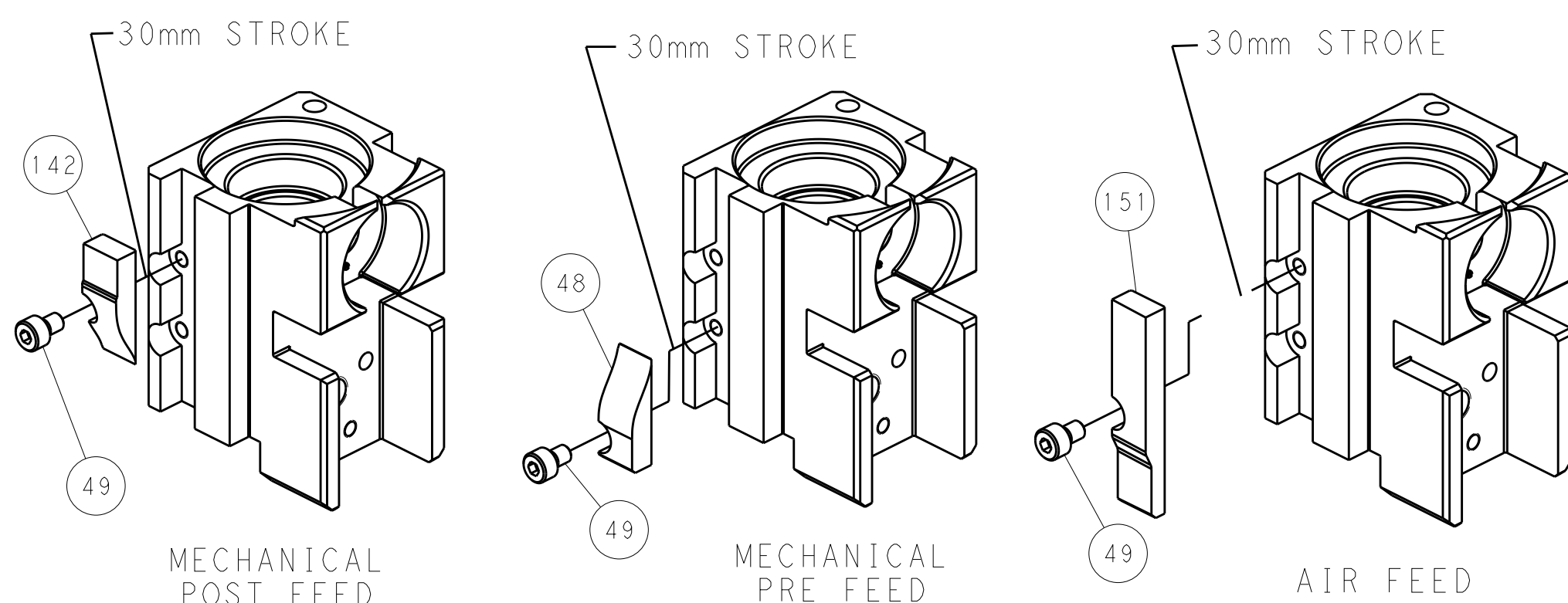

TERMINAL SUPPORT LOCATION

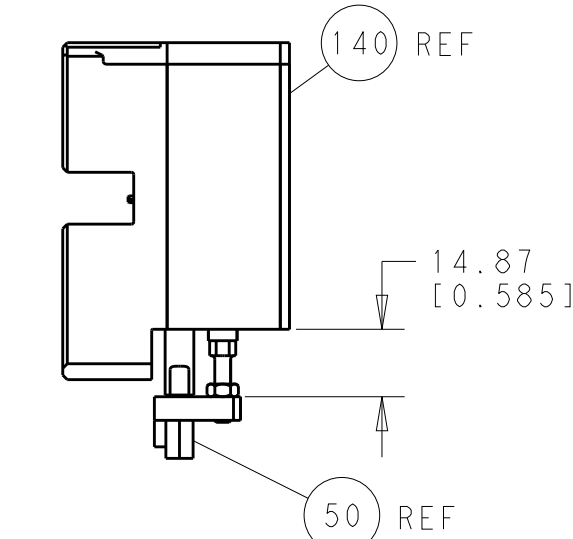

HOLDDOWN SET-UP

ITEM 30 LOCATED AT FRONT HOLES

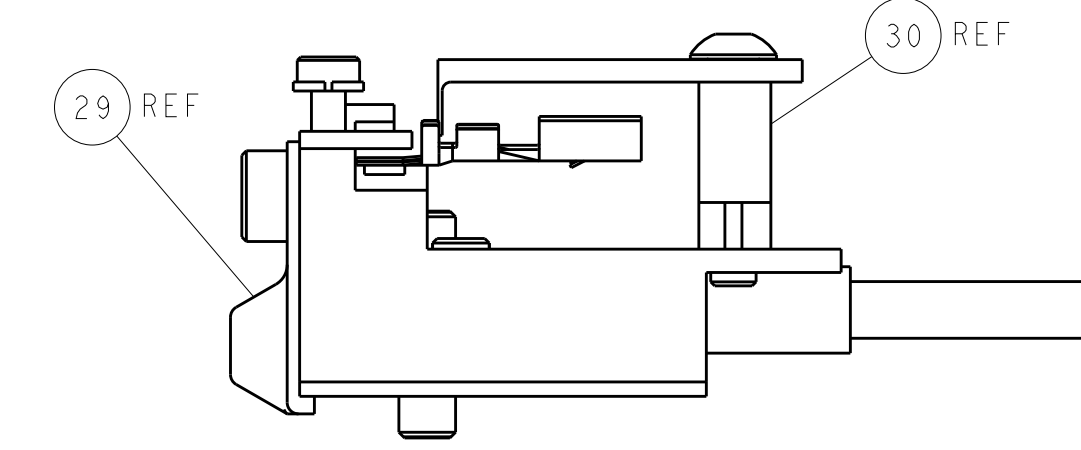

FEED TRACK POSITION GUIDE BY INSULATION BARREL

PACIFIC VERSION
 Shown on sheets 3 of 4 & 4 of 4
 (Atlantic version shown on sheets 1 of 4 & 2 of 4)

| | | | |
|--|---|--|---|
| <small>THIS DRAWING IS UNPUBLISHED. RELEASED FOR PUBLICATION. IT IS THE PROPERTY OF TYCO ELECTRONICS CORPORATION. IT IS TO BE USED ONLY FOR THE PURPOSES AND IN THE MANNER SPECIFIED BY THE DRAWING. IT IS TO BE RETURNED TO TYCO ELECTRONICS CORPORATION WHEN NO LONGER REQUIRED.</small> | | DWN: HOFFNER 23AUG2012 CHK: T. ELBIN 24 AUG2012 APVD: T. ELBIN 24AUG2012 | NAME: TE Connectivity Harrisburg, PA 17105-3608 |
| DIMENSIONS: mm TOLERANCES UNLESS OTHERWISE SPECIFIED: 0 PLC ±0.1 1 PLC ±0.1 2 PLC ±0.02 3 PLC ±0.005 4 PLC ±0.0005 ANGLES ±0.0005 | PRODUCT SPEC: - APPLICATION SPEC: - WEIGHT: - MATERIAL: - FINISH: - | SIZE: A1 CAGE CODE: 00779 DRAWING NO: C=2151748 | RESTRICTED TO: - SCALE: 1:1 SHEET: 4 OF: 4 REV: A |