

Lightning Surge Protectors for Electronics Equipment M-RESTER

LIGHTNING SURGE PROTECTOR FOR STANDARD SIGNAL LINE & PULSE USE

(conduit mount, weather-proof; 65 V DC line voltage)

Functions & Features

- Designed specifically for 4 - 20 mA DC and pulse signal line including both 4-wire and 2-wire transmitters
- Direct mount in a wiring conduit of outdoor enclosures
- Absorbs surges only without affecting instrumentation signal

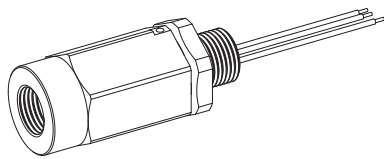

MODEL: MD6T-65-[1][2][3]

ORDERING INFORMATION

- Code number: MD6T-65-[1][2][3]
- Specify a code from below for each of [1] through [3].
(e.g. MD6T-65-00B)
- For the safety approval code 4, specify the product's destination country using Ordering Information Sheet (No. ESU-8284).

[1] SAFETY APPROVAL

- 0: None
- 4: ATEX flameproof

[2] WIRING CONDUIT

- 0: G 1/2 (Not selectable for ATEX flameproof approval)
- 1: 1/2 NPT
- 2: M20 × 1.5

[3] BODY MATERIAL

- B: Brass
- S: Stainless steel

CAUTION

The packing of the cable gland must be separate from the body. Choose an appropriate one for the environment in

which the surge protector is used.

GENERAL SPECIFICATIONS

Degree of protection: IP65

Wiring conduit: See 'Ordering information.'

Connection

Cable side: Euro type terminal block (Applicable wire size: 0.14 - 1.5 mm² (AWG26 - 16) for both stranded and solid wires; stripped length 6 mm)

Equipment side: Leadwires (leadwire diameter AWG20 for grounding; AWG22 for the protected equipment)

Body material: Nickel-plated brass or stainless steel 316

INSTALLATION

Operating temperature:

No Safety approval: -40 to +85°C (-40 to +185°F)

ATEX approval:

-40 to +80°C (-40 to +176°F) (T5)

-40 to +75°C (-40 to +167°F) (T6)

Mounting: Screwed into an electrical conduit of outdoor enclosures

Weight: 500 g (1.1 lb)

PERFORMANCE

Discharge voltage (peak voltage)

Line to line: 70 V min.

Line to ground: ±160 V min.

Max. surge voltage

Line to line: 100 V max.

Line to ground: ±650 V max.

(The maximum voltage that could pass through the surge protector. Protected equipment must be able to withstand this voltage for a very short time period.)

Response time:

Line to line: ≤ 4 nsec.

Line to ground: ≤ 20 nsec.

Leakage current:

Line to line: ≤ 5 μA @ 70 V DC

Line to ground: ≤ 5 μA @ ±160 V DC

Discharge current capacity: 10000 A (8/ 20 μsec.)

Max. load current: 100 mA

Internal series resistance: Approx. 22 Ω including return

Max. line voltage

Without safety approval: 70 V DC

With safety approval: 66 V DC

Capacitance @ 1 kHz:

Line to line: ≤ 2500 pF

Line to ground: ≤ 100 pF

STANDARDS & APPROVALS

EU conformity:

ATEX Directive

Ex d EN 60079-1

EMC Directive

EMI EN 61000-6-4

EMS EN 61000-6-2

RoHS Directive

EN 50581

Safety approval:

ATEX: Flameproof

Ⓔ II 2G, Ex d IIC, T5 and T6

(EN 60079-1)

CONNECTION EXAMPLES

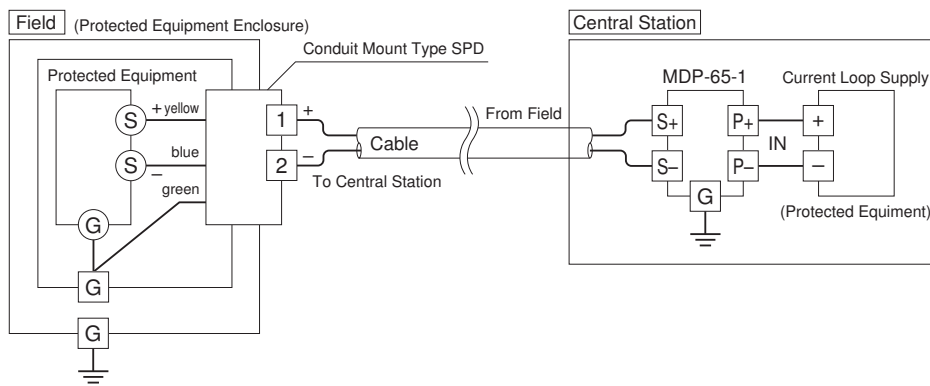

Connect the MD6T's green leadwire to the ground terminal inside the protected equipment enclosure to ground through the enclosure's outside ground terminal.

If the enclosure does not have an inside ground terminal, connect the green leadwire directly to the outside ground wire pulled inside the enclosure. Keep the ground wire as short as possible.

EXTERNAL DIMENSIONS unit: mm (inch)

■ WITHOUT SAFETY APPROVAL

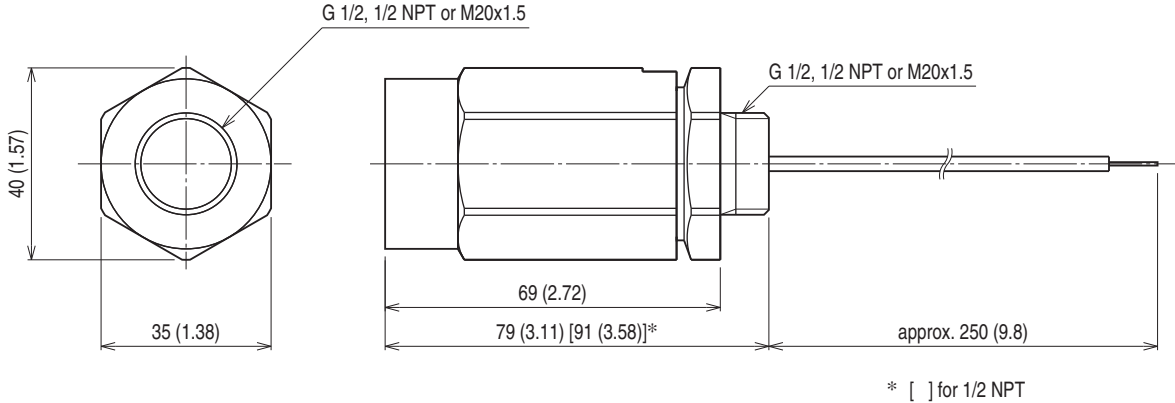

* [] for 1/2 NPT

■ WITH SAFETY APPROVAL

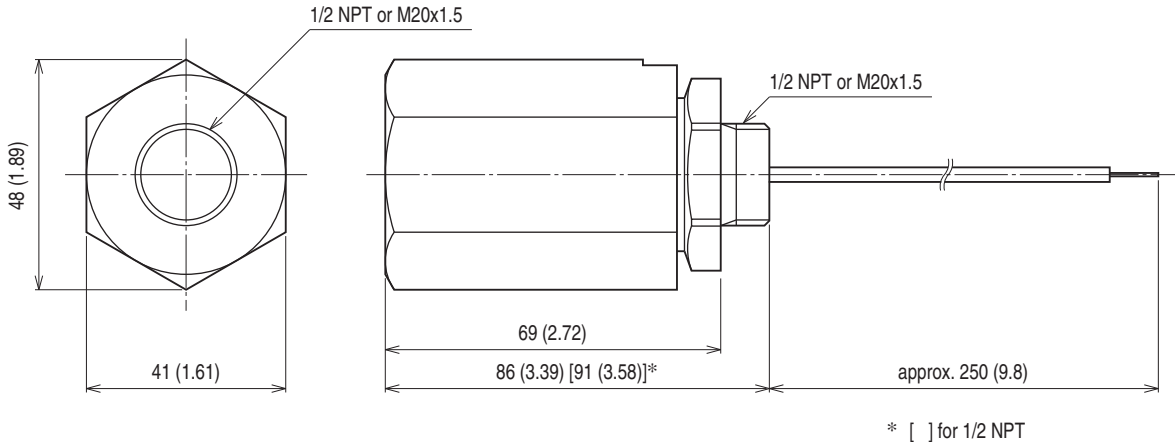

* [] for 1/2 NPT

SCHEMATIC CIRCUITRY & CONNECTION DIAGRAM

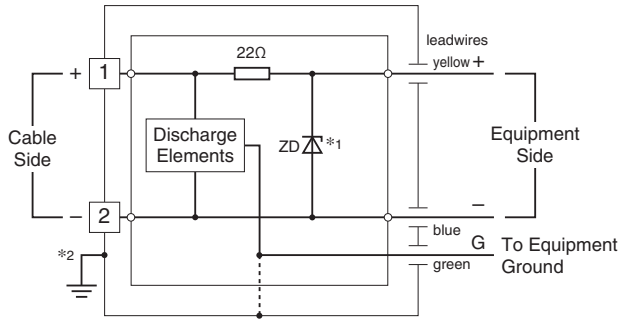

*1. The zenor diode has polarity. Zero-cross signal cannot be connected.
 *2. Use only when the signal line require functional grounding.
 This is NOT for surge protection.



Specifications are subject to change without notice.