

RoHS **Pb** **215SP Series, 5x20 mm, Time-Lag Fuse (Slo-Blo®)**

Description

5x20mm Time-Lag surge withstanding ceramic body cartridge fuse designed to IEC specification

Features

- Designed to International (IEC) Standards for use globally
- Meets the IEC 60127-2, Sheet 5 specification for Time-Lag Fuses
- RoHS compliant and Pb-free

Applications

Used as supplementary protection in appliance or utilization equipment to provide individual protection for components or internal circuits.

Agency Approvals

Agency	Agency File Number	Ampere Range
	Certificate No. Leaded NBK080205-E10480B NBK250702-E10480F	1A – 5A 6.3A – 10A
	Certificate No. CQC10012041490	1A – 6.3A
	Certificate No. SU05001-2011B SU05001-10001 SU05001-10002	1A – 2.5A 3.15A – 6.3A 8A
	Recognised File No. Guide No. E10480 JDYX2	1A – 10A
	File No. Acc. Class No. 029862 LR1422-30	1A – 10A
	Licence. No. 40013521	1 – 8A
		1A – 10A

Electrical Characteristics for Series

% of Ampere Rating	Ampere Rating	Opening Time
210%	1A - 3.15A	30 minutes, Maximum
	4A - 6.3A	30 minutes, Maximum
	8A - 10A	30 minutes, Maximum
275%	1A - 3.15A	.75 sec. Min.; 80 secs. Max.
	4A - 6.3A	.75 sec. Min.; 80 secs. Max.
	8A - 10A	.75 sec. Min.; 80 secs. Max.
400%	1A - 3.15A	.095 sec. Min.; 5 secs. Max.
	4A - 6.3A	.150 sec. Min.; 5 secs. Max.
	8A - 10A	.150 sec. Min.; 5 secs. Max.
1000%	1A - 3.15A	.010 sec. Min.; .150 secs. Max.
	4A - 6.3A	.010 sec. Min.; .150 secs. Max.
	8A - 10A	.010 sec. Min.; .150 secs. Max.

Electrical Characteristic Specifications by Item

Amp Code	Amp Rating	Voltage Rating	Interrupting Rating	Nominal Resistance Cold Ohms (Ohms)	Nominal Melting I ² t (A ² sec)	Maximum Voltage Drop at Rated Current (mV)	Maximum Power Dissipation at 1.5In Rated Current (W)	Agency Approvals						
001	1	250	1500 A @ 250 VAC	0.1515	1.52000	350	2.5	x	x	x	x	x	x	x
1.25	1.25	250		0.1074	3.20000	300	2.5	x	x	x	x	x	x	x
01.6	1.6	250		0.0707	6.83000	200	2.5	x	x	x	x	x	x	x
002	2	250		0.0566	11.68000	190	2.5	x	x	x	x	x	x	x
02.5	2.5	250		0.0386	22.29000	180	2.5	x	x	x	x	x	x	x
3.15	3.15	250		0.0283	43.25500	140	4	x	x	x	x	x	x	x
004	4	250		0.0185	46.96000	100	4	x	x	x	x	x	x	x
005	5	250		0.0153	66.09500	100	4	x	x	x	x	x	x	x
06.3	6.3	250		0.0108	128.75000	100	4	x	x	x	x	x	x	x
008	8	250		0.0092	209.88000	100	4	x		x	x	x	x	x
010	10	250		0.0066	333.56500	100	4	x			x	x		x

I²t test at 10x rated current

© 2012 Littelfuse, Inc.

Specifications are subject to change without notice.
Please refer to www.littelfuse.com/series/215SP.html for current information.

Revised: June 3, 2012

215SP Series

215SP Series

Temperature Derating Curve

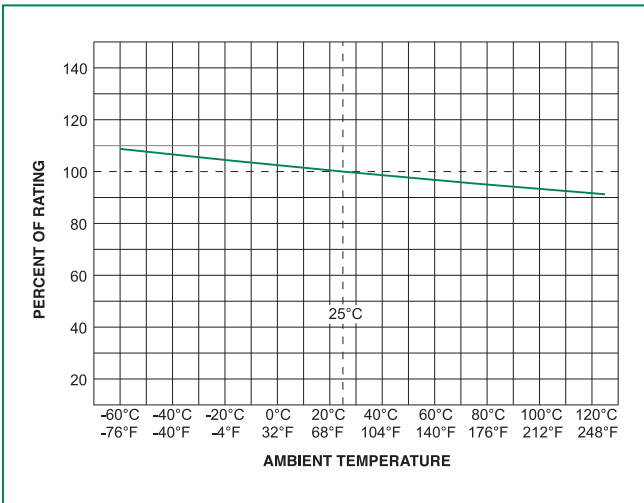

Average Time Current Curves

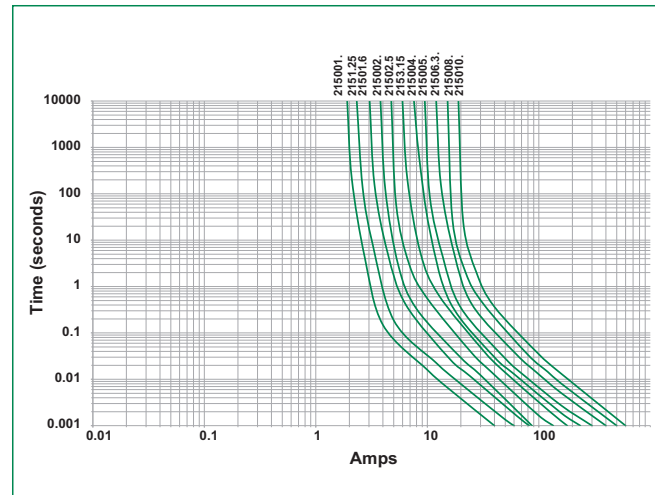

Soldering Parameters - Wave Soldering

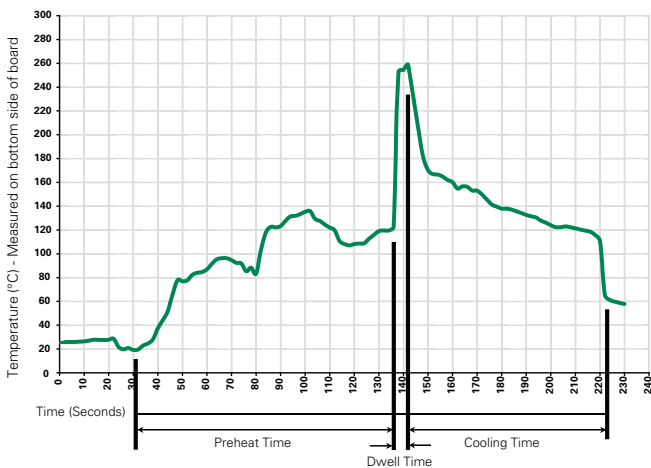

Recommended Process Parameters:

Wave Parameter	Lead-Free Recommendation
Preheat: (Depends on Flux Activation Temperature)	(Typical Industry Recommendation)
Temperature Minimum:	100° C
Temperature Maximum:	150° C
Preheat Time:	60-180 seconds
Solder Pot Temperature:	260° C Maximum
Solder Dwell Time:	2-5 seconds

Recommended Hand-Solder Parameters:

Solder Iron Temperature: 350° C +/- 5°C
 Heating Time: 5 seconds max.

Note: These devices are not recommended for IR or Convection Reflow process.

Different values of A and B available, please contact the Littelfuse sales representative in your region:

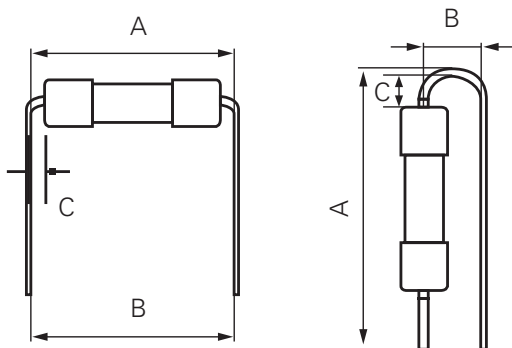

For the pigtailed fuse, please follow the recommendations below for axial lead forming and mounting into PCB:

Lead forming:

The distance C between cap flat surface and axial lead shall be greater than 1.0 mm.

PCB mounting:

According to the standard of IPC-A-610, the distance between PCB and fuse cap is recommended to be a minimum of 1.5 mm.

Product Characteristics

Materials	Body: Ceramic Cap: Nickel-plated Brass Leads: Tin-plated Copper
Terminal Strength	MIL-STD-202G, Method 211A, Test Condition A
Solderability	Reference IEC 60127 Second Edition 2003-01 Annex A
Product Marking	Cap 1: Brand logo, current and voltage ratings Cap 2: Agency approval marks

Operating Temperature	-55°C to +125°C
Thermal Shock	MIL-STD-202G, Method 107G, Test Condition B (5 cycles, -65°C to +125°C)
Vibration	MIL-STD-202G, Method 201A
Humidity	MIL-STD-202G, Method 103B, Test Condition A (High RH (95%) and elevated temp (40°C) for 240 hours)
Salt Spray	MIL-STD-202G, Method 101D, Test Condition B

Dimensions

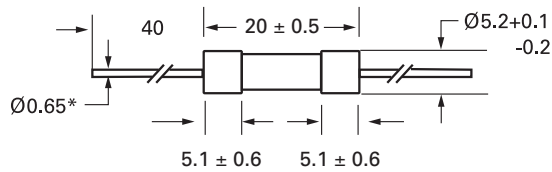

* 8A and 10A have 0.8mm diameter
 All unit in mm.

Part Numbering System

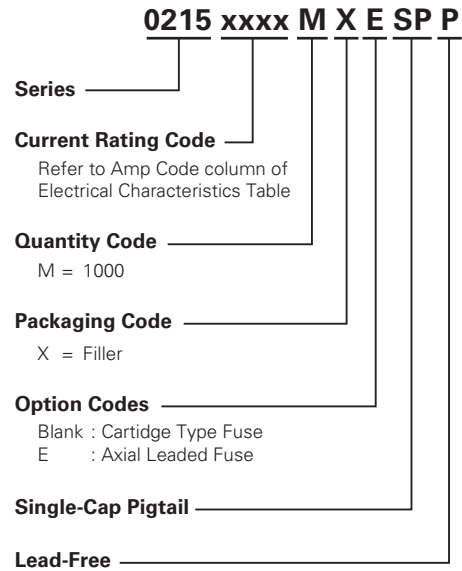

Packaging

Packaging Option	Packaging Specification	Quantity	Packaging Code	Reel Size
215SP Series				
Bulk	N/A	1000	MXE	N/A