



Little Star® 1 W Power SMD LED White



20784-1

DESCRIPTION

The VLMW712U2U3XV, VLMW712T3U3US, and VLMW712T2T3QN are the most robust and light efficient LEDs in the market. Using new nitride phosphor system display negligible color shift across operation temperature range. With its extremely high level of brightness and the ultra low high profile, which is only 1.5 mm are highly suitable for both conventional lighting and specialized application such as automotive signal lights, traffic lights, channel lights, tube lights and garden lights among others.

PRODUCT GROUP AND PACKAGE DATA

- Product group: LED
- Package: SMD Little Star
- Product series: power
- Angle of half intensity: $\pm 60^\circ$

FEATURES

- Super high brightness surface mount LED
- High flux output; up to 113 lm
- 120° viewing angle
- Compact package outline (L x W x H) in mm: 6.0 x 6.0 x 1.5
- Ultra low height profile - 1.5 mm
- Designed for high current drive; up to 350 mA
- Low thermal resistance; $R_{thJP} = 10 \text{ K/W}$
- Qualified according to JEDEC moisture sensitivity level 2a
- Compatible with IR reflow soldering
- Little Star® are class 1M LED products. Do not view directly with optical instrument
- Compliant to RoHS Directive 2002/95/EC and in accordance to WEEE 2002/96/EC
- ESD-withstand voltage: up to 2 kV according to JESD22-A114-B



RoHS
COMPLIANT

APPLICATIONS

- Communication: flashLED
- Industry: white goods (e.g.: oven, microwave, etc.)
- Lighting: garden light, architecture lighting, general lighting, etc.

PARTS TABLE												
PART	COLOR	LUMINOUS INTENSITY (mcd)			at I_F (mA)	WAVELENGTH (nm)			FORWARD VOLTAGE (V)			TECHNOLOGY
		MIN.	TYP.	MAX.		MIN.	TYP.	MAX.	MIN.	TYP.	MAX.	
VLMW712U2U3XV-GS08	Cool white	-	33 500	-	350	-	-	-	3	3.5	4	InGaN
VLMW712T3U3US-GS08	Natural white	-	29 400	-	350	-	-	-	3	3.6	4	InGaN
VLMW712T2T3QN-GS08	Warm white	-	25 000	-	350	-	-	-	-	3.6	4	InGaN

ABSOLUTE MAXIMUM RATINGS ($T_{amb} = 25^\circ\text{C}$, unless otherwise specified)				
VLMW712U2U3XV, VLMW712T3U3US, VLMW712T2T3QN				
PARAMETER	TEST CONDITION	SYMBOL	VALUE	UNIT
Forward current		I_F	350	mA
Power dissipation		P_{tot}	1.4	W
Junction temperature		T_j	+ 120	$^\circ\text{C}$
Surge current $t < 10 \mu\text{s}$, $d = 0.1$		I_{FM}	1000	mA
Operating temperature range		T_{amb}	- 40 to + 100	$^\circ\text{C}$
Storage temperature range		T_{stg}	- 40 to + 100	$^\circ\text{C}$
Thermal resistance junction/pin		R_{thJP}	10	K/W

Note

- Not designed for reverse operation



OPTICAL AND ELECTRICAL CHARACTERISTICS ($T_{amb} = 25\text{ }^{\circ}\text{C}$, unless otherwise specified)						
VLMW712U2U3XV, COOL WHITE						
PARAMETER	TEST CONDITION	SYMBOL	MIN.	TYP.	MAX.	UNIT
Luminous intensity	$I_F = 350\text{ mA}$	ϕ	87 400	100 000	113 600	mlm
		I_V	-	33 500	-	mcd
Chromaticity coordinate x acc. to CIE 1931	$I_F = 350\text{ mA}$	x	-	0.37	-	
Chromaticity coordinate y acc. to CIE 1931	$I_F = 350\text{ mA}$	y	-	0.38	-	
Angle of half intensity	$I_F = 350\text{ mA}$	φ	-	± 60	-	deg
Forward voltage ⁽¹⁾	$I_F = 350\text{ mA}$	V_F	3	3.5	4	V
Temperature coefficient of V_F	$I_F = 350\text{ mA}$	TC_{V_F}	-	- 3	-	mV/K
Temperature coefficient of I_V	$I_F = 350\text{ mA}$	TC_{I_V}	-	- 0.4	-	%/K

Note

⁽¹⁾ Forward voltages are tested at a current pulse duration of 1 ms and a tolerance of $\pm 0.05\text{ V}$

OPTICAL AND ELECTRICAL CHARACTERISTICS ($T_{amb} = 25\text{ }^{\circ}\text{C}$, unless otherwise specified)						
VLMW712T3U3US, NATURAL WHITE						
PARAMETER	TEST CONDITION	SYMBOL	MIN.	TYP.	MAX.	UNIT
Luminous intensity	$I_F = 350\text{ mA}$	ϕ	76 500	90 000	113 000	mlm
		I_V	-	29 700	-	mcd
Chromaticity coordinate x acc. to CIE 1931	$I_F = 350\text{ mA}$	x	-	0.33	-	
Chromaticity coordinate y acc. to CIE 1931	$I_F = 350\text{ mA}$	y	-	0.33	-	
Angle of half intensity	$I_F = 350\text{ mA}$	φ	-	± 60	-	deg
Forward voltage ⁽¹⁾	$I_F = 350\text{ mA}$	V_F	3	3.6	4	V
Temperature coefficient of V_F	$I_F = 350\text{ mA}$	TC_{V_F}	-	- 3	-	mV/K
Temperature coefficient of I_V	$I_F = 350\text{ mA}$	TC_{I_V}	-	- 0.4	-	%/K

Note

⁽¹⁾ Forward voltages are tested at a current pulse duration of 1 ms and a tolerance of $\pm 0.05\text{ V}$

OPTICAL AND ELECTRICAL CHARACTERISTICS ($T_{amb} = 25\text{ }^{\circ}\text{C}$, unless otherwise specified)						
VLMW712T2T3QN, WARM WHITE						
PARAMETER	TEST CONDITION	SYMBOL	MIN.	TYP.	MAX.	UNIT
Luminous intensity	$I_F = 350\text{ mA}$	ϕ	67 200	-	87 400	mlm
		I_V	-	25 000	-	mcd
Chromaticity coordinate x acc. to CIE 1931	$I_F = 350\text{ mA}$	x	-	0.44	-	
Chromaticity coordinate y acc. to CIE 1931	$I_F = 350\text{ mA}$	y	-	0.41	-	
Angle of half intensity	$I_F = 350\text{ mA}$	φ	-	± 60	-	deg
Forward voltage ⁽¹⁾	$I_F = 350\text{ mA}$	V_F	3	3.6	4	V
Temperature coefficient of V_F	$I_F = 350\text{ mA}$	TC_{V_F}	-	- 3	-	mV/K
Temperature coefficient of I_V	$I_F = 350\text{ mA}$	TC_{I_V}	-	- 0.4	-	%/K

Note

⁽¹⁾ Forward voltages are tested at a current pulse duration of 1 ms and a tolerance of $\pm 0.05\text{ V}$



LUMINOUS INTENSITY/FLUX CLASSIFICATION		
GROUP	LUMINOUS FLUX Φ_v (lm) CORRELATION TABLE	
STANDARD	MIN.	MAX.
S2	51 700	59 000
S3	59 000	67 200
T2	67 200	76 500
T3	76 500	87 400
U2	87 400	99 400
U3	99 400	113 600

Note

- Luminous intensity is tested at a current pulse duration of 25 ms and an accuracy of $\pm 11\%$.
The above type numbers represent the order groups which include only a few brightness groups. Only one group will be shipped on each reel (there will be no mixing of two groups on each reel). In order to ensure availability, single brightness groups will not be orderable. In a similar manner for colors where color groups are measured and binned, single color groups will be shipped in any one reel. In order to ensure availability, single color groups will not be orderable.

CHROMATICITY COORDINATED GROUPS FOR COOL WHITE SMD LED		
BIN	Cx	Cy
XM	0.301	0.342
	0.314	0.353
	0.315	0.343
	0.303	0.333
	0.301	0.342
XN	0.303	0.333
	0.315	0.343
	0.316	0.332
	0.305	0.322
	0.303	0.333
XO	0.305	0.322
	0.316	0.332
	0.318	0.319
	0.308	0.311
	0.305	0.322
XP	0.308	0.311
	0.318	0.319
	0.32	0.301
	0.311	0.293
	0.308	0.311
WM	0.314	0.353
	0.329	0.366
	0.329	0.354
	0.315	0.343
	0.314	0.353
WN	0.315	0.343
	0.329	0.354
	0.329	0.343
	0.316	0.332
	0.315	0.343
WO	0.316	0.332
	0.329	0.343
	0.329	0.33
	0.318	0.319
	0.316	0.332
WP	0.318	0.319
	0.329	0.33
	0.329	0.319
	0.319	0.31
	0.318	0.319



CHROMATICITY COORDINATED GROUPS FOR COOL WHITE SMD LED		
BIN	Cx	Cy
WQ	0.319	0.31
	0.329	0.319
	0.33	0.311
	0.32	0.301
	0.319	0.31
VM	0.329	0.366
	0.348	0.383
	0.347	0.368
	0.329	0.354
	0.329	0.366
VN	0.329	0.354
	0.347	0.368
	0.346	0.357
	0.329	0.343
	0.329	0.354
VO	0.329	0.343
	0.346	0.357
	0.344	0.343
	0.329	0.33
	0.329	0.343
VP	0.329	0.33
	0.344	0.343
	0.343	0.331
	0.329	0.319
	0.329	0.33

Note

- Chromaticity coordinate groups are tested at a current pulse duration of 25 ms and a tolerance of ± 0.01 .

CHROMATICITY COORDINATED GROUPS FOR NATURAL WHITE SMD LED		
BIN	Cx	Cy
UM	0.348	0.383
	0.367	0.4
	0.364	0.383
	0.347	0.368
UN	0.347	0.368
	0.364	0.383
	0.362	0.372
UO	0.346	0.357
	0.346	0.357
	0.362	0.372
	0.359	0.356
UP	0.344	0.343
	0.359	0.356
	0.357	0.343
	0.343	0.331
TM	0.367	0.4
	0.364	0.383
	0.381	0.394
	0.386	0.411



CHROMATICITY COORDINATED GROUPS FOR NATURAL WHITE SMD LED		
BIN	Cx	Cy
TN	0.364	0.383
	0.362	0.372
	0.378	0.381
	0.381	0.394
TO	0.362	0.372
	0.359	0.356
	0.374	0.365
TP	0.378	0.381
	0.359	0.356
	0.357	0.343
SM	0.37	0.351
	0.374	0.365
	0.386	0.411
	0.381	0.394
SN	0.396	0.404
	0.402	0.421
	0.381	0.394
	0.378	0.381
SO	0.392	0.389
	0.396	0.404
	0.378	0.381
	0.374	0.365
SP	0.387	0.373
	0.392	0.389
	0.374	0.365
	0.37	0.351
	0.382	0.358
	0.387	0.373

Note

- Chromaticity coordinate groups are tested at a current pulse duration of 25 ms and a tolerance of ± 0.01 .

CHROMATICITY COORDINATED GROUPS FOR WARM WHITE SMD LED		
BIN	Cx	Cy
QM	0.421	0.433
	0.437	0.438
	0.43	0.421
	0.415	0.416
	0.421	0.433
QN	0.415	0.416
	0.43	0.421
	0.423	0.405
	0.409	0.4
	0.415	0.416
QO	0.409	0.4
	0.423	0.405
	0.416	0.387
	0.402	0.382
	0.409	0.4



CHROMATICITY COORDINATED GROUPS FOR WARM WHITE SMD LED		
BIN	Cx	Cy
QP	0.402	0.382
	0.416	0.387
	0.409	0.372
	0.397	0.367
	0.402	0.382
PM	0.437	0.438
	0.452	0.443
	0.444	0.426
	0.43	0.421
	0.437	0.438
PN	0.43	0.421
	0.444	0.426
	0.436	0.409
	0.423	0.405
	0.43	0.421
PO	0.423	0.405
	0.436	0.409
	0.428	0.392
	0.416	0.387
	0.423	0.405
PP	0.416	0.387
	0.428	0.392
	0.421	0.377
	0.409	0.372
	0.416	0.387
NM	0.452	0.443
	0.469	0.448
	0.46	0.431
	0.444	0.426
	0.452	0.443
NN	0.444	0.426
	0.46	0.431
	0.451	0.414
	0.436	0.409
	0.444	0.426
NO	0.436	0.409
	0.451	0.414
	0.443	0.397
	0.428	0.392
	0.436	0.409
NP	0.428	0.392
	0.443	0.397
	0.435	0.382
	0.421	0.377
	0.428	0.392

Note

- Chromaticity coordinate groups are tested at a current pulse duration of 25 ms and a tolerance of ± 0.01.



TYPICAL CHARACTERISTICS (T_{amb} = 25 °C, unless otherwise specified)

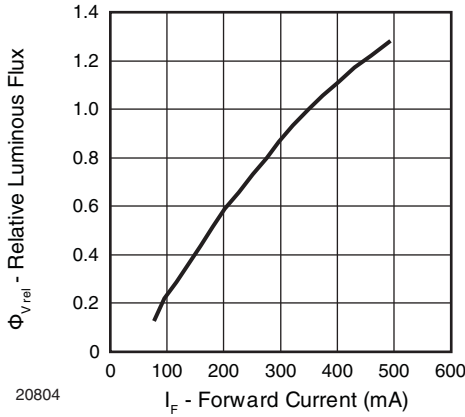

Fig. 1 - Relative Luminous Flux vs. Forward Current

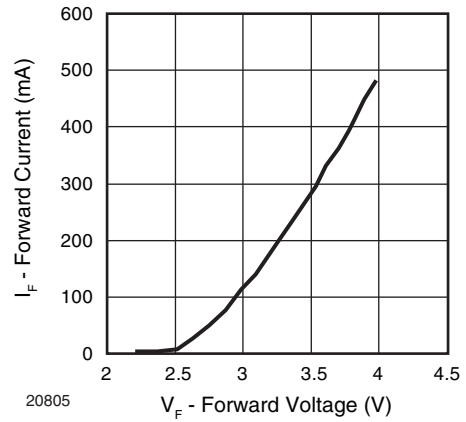

Fig. 4 - Forward Current vs. Forward Voltage

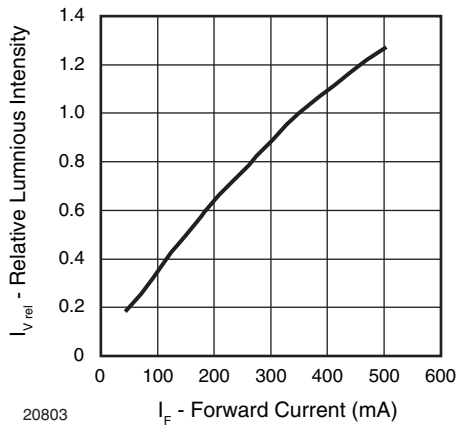

Fig. 2 - Relative Luminous Intensity vs. Forward Current

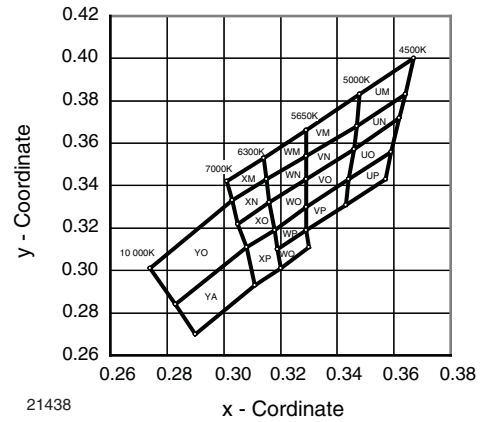

Fig. 5 - Coordinates of Color Groups for Cool White

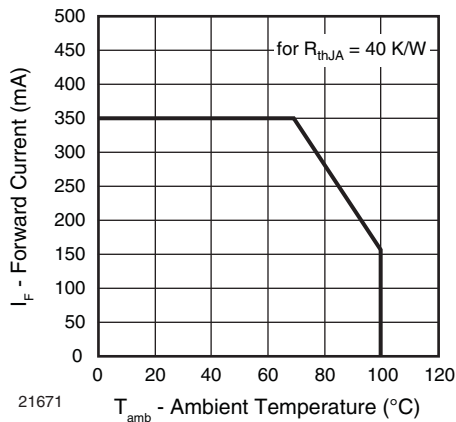

Fig. 3 - Forward Current vs. Solder Point Temperature

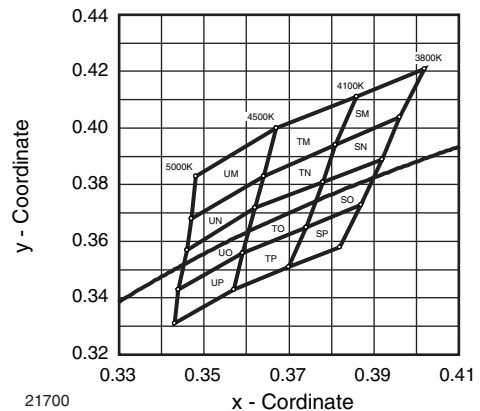

Fig. 6 - Coordinates of Color Groups for Natural White

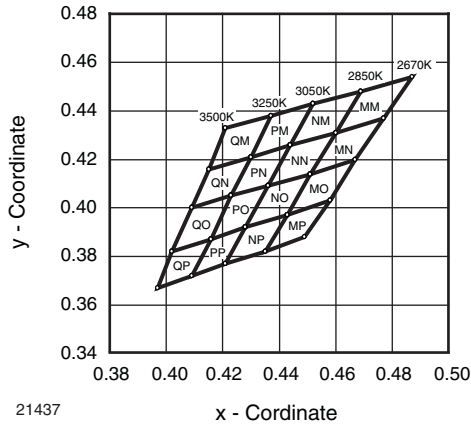

Fig. 7 - Coordinates of Color Groups for Warm White

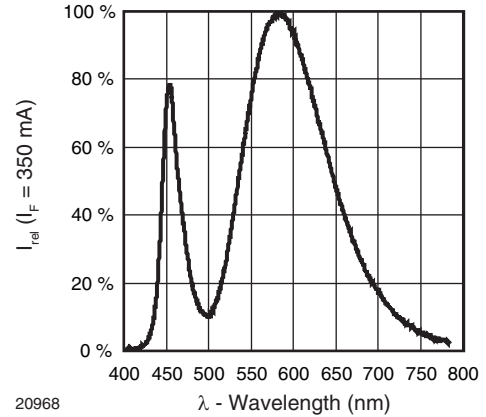

Fig. 10 - Relative Spectrale Emission for Warm White

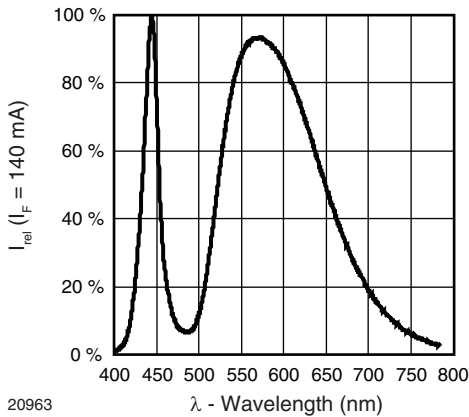

Fig. 8 - Relative Spectrale Emission for Cool White

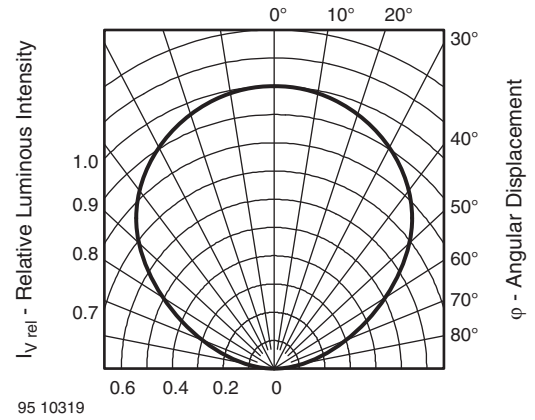

Fig. 11 - Relative Luminous Intensity vs. Angular Displacement

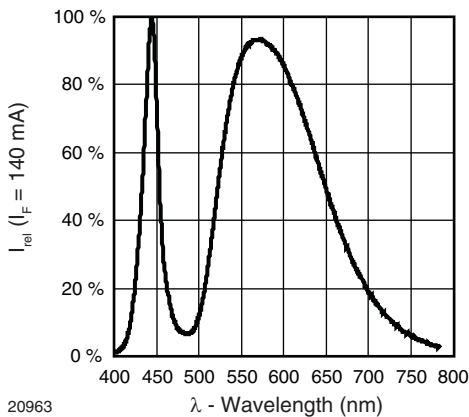
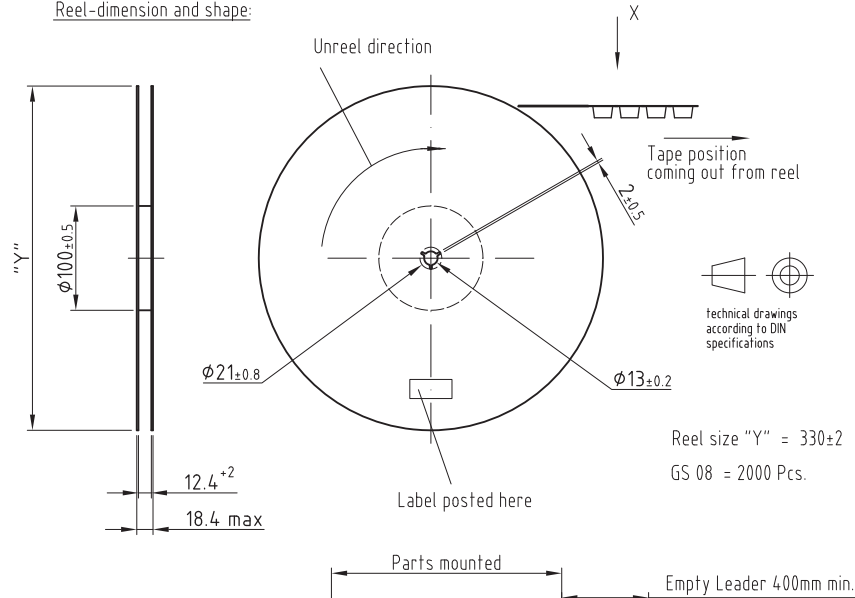

Fig. 9 - Relative Spectrale Emission for Natural White



TAPING DIMENSIONS in millimeters

Reel-dimension and shape:



Leader and trailer tape:

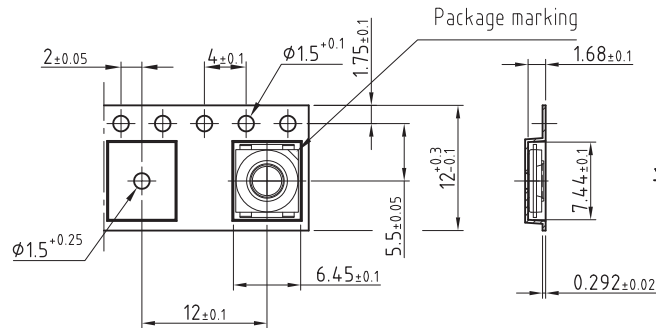
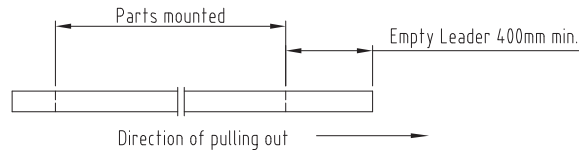

Drawing-No.: 9.800-5094.01-4

Issue: 3; 22.01.08

20846



PACKAGE DIMENSIONS/SOLDERING PADS DIMENSIONS in millimeters

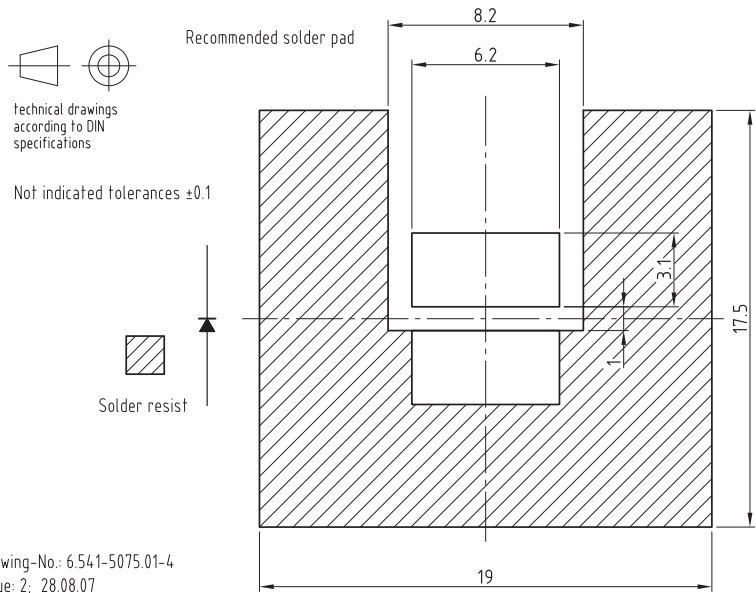
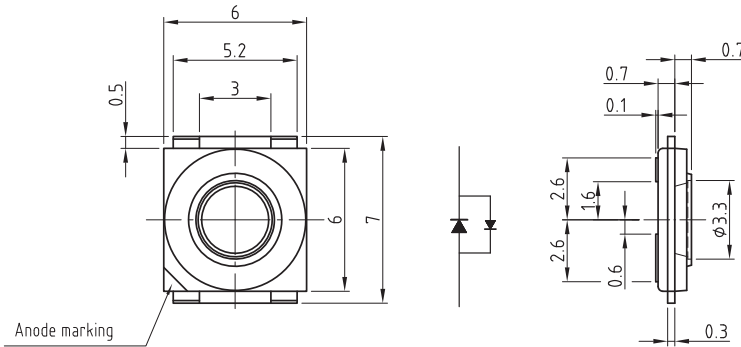

Drawing-No.: 6.541-5075.01-4
Issue: 2; 28.08.07
20847

SOLDERING PROFILE

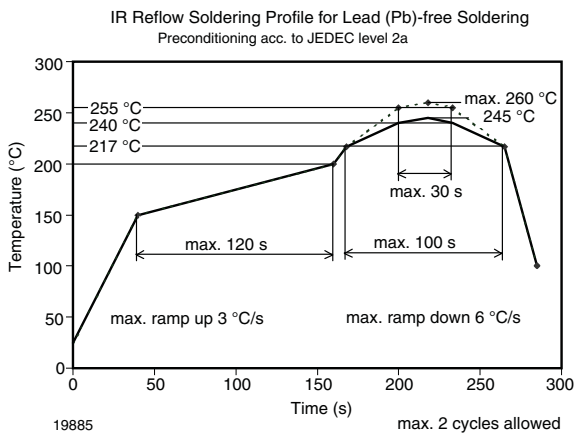
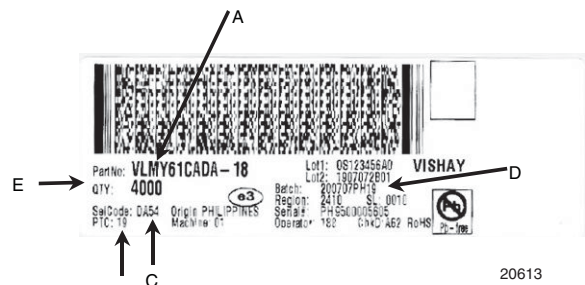

Fig. 12 - Vishay Lead (Pb)-free Reflow Soldering Profile (acc. to J-STD-020C)

BAR CODE PRODUCT LABEL (example)



- A. Type of component
- B. Manufacturing plant
- C. SEL - selection code (bin):
e.g.: DA = code for luminous intensity group
5 = code for color group
- D. Batch no.
20070 = year 2007, week 07
PH19 = plant code
- E. Total quantity



DRY PACKING

The reel is packed in an anti-humidity bag to protect the devices from absorbing moisture during transportation and storage.

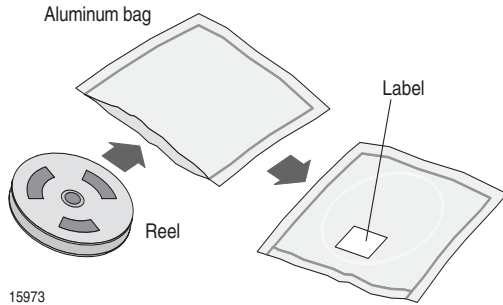

ESD PRECAUTION

Proper storage and handling procedures should be followed to prevent ESD damage to the devices especially when they are removed from the antistatic shielding bag. Electro-static sensitive devices warning labels are on the packaging.

VISHAY SEMICONDUCTORS STANDARD BAR CODE LABELS

The Vishay Semiconductors standard bar code labels are printed at final packing areas. The labels are on each packing unit and contain Vishay Semiconductors specific data.

FINAL PACKING

The sealed reel is packed into a cardboard box. A secondary cardboard box is used for shipping purposes.

RECOMMENDED METHOD OF STORAGE

Dry box storage is recommended as soon as the aluminum bag has been opened to prevent moisture absorption. The following conditions should be observed, if dry boxes are not available:

- Storage temperature 10 °C to 30 °C
- Storage humidity ≤ 60 % RH max.

After more than 672 h under these conditions moisture content will be too high for reflow soldering.

In case of moisture absorption, the devices will recover to the former condition by drying under the following condition: 192 h at 40 °C + 5 °C/- 0 °C and < 5 % RH (dry air/nitrogen) or

96 h at 60 °C + 5 °C and < 5 % RH for all device containers or

24 h at 100 °C + 5 °C not suitable for reel or tubes.

An EIA JEDEC standard JESD22-A112 level 2a label is included on all dry bags.

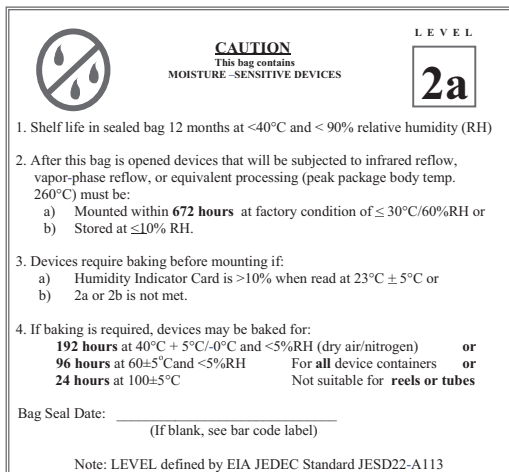

Example of JESD22-A112 level 2a label



Disclaimer

ALL PRODUCT, PRODUCT SPECIFICATIONS AND DATA ARE SUBJECT TO CHANGE WITHOUT NOTICE TO IMPROVE RELIABILITY, FUNCTION OR DESIGN OR OTHERWISE.

Vishay Intertechnology, Inc., its affiliates, agents, and employees, and all persons acting on its or their behalf (collectively, "Vishay"), disclaim any and all liability for any errors, inaccuracies or incompleteness contained in any datasheet or in any other disclosure relating to any product.

Vishay makes no warranty, representation or guarantee regarding the suitability of the products for any particular purpose or the continuing production of any product. To the maximum extent permitted by applicable law, Vishay disclaims (i) any and all liability arising out of the application or use of any product, (ii) any and all liability, including without limitation special, consequential or incidental damages, and (iii) any and all implied warranties, including warranties of fitness for particular purpose, non-infringement and merchantability.

Statements regarding the suitability of products for certain types of applications are based on Vishay's knowledge of typical requirements that are often placed on Vishay products in generic applications. Such statements are not binding statements about the suitability of products for a particular application. It is the customer's responsibility to validate that a particular product with the properties described in the product specification is suitable for use in a particular application. Parameters provided in datasheets and/or specifications may vary in different applications and performance may vary over time. All operating parameters, including typical parameters, must be validated for each customer application by the customer's technical experts. Product specifications do not expand or otherwise modify Vishay's terms and conditions of purchase, including but not limited to the warranty expressed therein.

Except as expressly indicated in writing, Vishay products are not designed for use in medical, life-saving, or life-sustaining applications or for any other application in which the failure of the Vishay product could result in personal injury or death. Customers using or selling Vishay products not expressly indicated for use in such applications do so at their own risk and agree to fully indemnify and hold Vishay and its distributors harmless from and against any and all claims, liabilities, expenses and damages arising or resulting in connection with such use or sale, including attorneys fees, even if such claim alleges that Vishay or its distributor was negligent regarding the design or manufacture of the part. Please contact authorized Vishay personnel to obtain written terms and conditions regarding products designed for such applications.

No license, express or implied, by estoppel or otherwise, to any intellectual property rights is granted by this document or by any conduct of Vishay. Product names and markings noted herein may be trademarks of their respective owners.