



# 21143 PCI/CardBus 10/100 Ethernet LAN Controller

*Networking Silicon*

---

**Preliminary Datasheet**

## Product Features

- Fully compliant with Revision 2.1 of the *PCI Local Bus Specification* and with Revision 1.0 of the *PCI Bus Power Management Interface Specification*.
- Fully compliant with Revision 1.0 of the *Advanced Configuration and Power Interface (ACPI) Specification* and with Revision 1.0 of the *Network Device Class Power Management Specification*, under the OnNow Architecture for Microsoft's *PC 97 Hardware Design Guide* and *PC 98 System Design Guide*.
- Supports IEEE 802.3 with full Auto-Negotiation algorithm of full-duplex and half-duplex operation for 10 Mb/s and 100 Mb/s (NWAY).
- Supports IEEE 802.3 and ANSI 8802-3 Ethernet standards.
- Supports direct memory access (DMA) and has direct interface to both the CardBus\* and PCI local bus.
- Provides glueless 32-bit PCI bus master interface.
- Contains large independent receive and transmit FIFOs.
- Contains internal PCS and scrambler/descrambler for MII/SYM interface for 100BASE-TX.
- Contains onchip integrated AUI port and a 10BASE-T transceiver.
- Supports autodetection between 10BASE-T, AUI, and MII/SYM ports.
- Provides an upgradable boot ROM interface up to 256KB.
- Supports remote wake-up-LAN and Magic Packet\* with the SecureON™ password option.
- Supports PCI/CardBus clock speed frequency from dc to 33 MHz; network operation with PCI clock from 20 MHz to 33 MHz.
- Implements low-power management with two power-saving modes (sleep and snooze).
- Implements low-power, 3.3-V CMOS technology.

---

**Notice:** This document contains preliminary information on new products in production. The specifications are subject to change without notice. Verify with your local Intel sales office that you have the latest datasheet before finalizing a design.

---

Information in this document is provided in connection with Intel products. No license, express or implied, by estoppel or otherwise, to any intellectual property rights is granted by this document. Except as provided in Intel's Terms and Conditions of Sale for such products, Intel assumes no liability whatsoever, and Intel disclaims any express or implied warranty, relating to sale and/or use of Intel products including liability or warranties relating to fitness for a particular purpose, merchantability, or infringement of any patent, copyright or other intellectual property right. Intel products are not intended for use in medical, life saving, or life sustaining applications.

Intel may make changes to specifications and product descriptions at any time, without notice.

Designers must not rely on the absence or characteristics of any features or instructions marked "reserved" or "undefined." Intel reserves these for future definition and shall have no responsibility whatsoever for conflicts or incompatibilities arising from future changes to them.

The 21143 PCI/CardBus 10/100 Ethernet LAN Controller may contain design defects or errors known as errata which may cause the product to deviate from published specifications. Current characterized errata are available on request.

Contact your local Intel sales office or your distributor to obtain the latest specifications and before placing your product order.

Copies of documents which have an ordering number and are referenced in this document, or other Intel literature, may be obtained by calling 1-800-548-4725 or by visiting Intel's website at <http://www.intel.com>.

Copyright © Intel Corporation, 1998

\*Third-party brands and names are the property of their respective owners.

# Contents

<b>1.0</b>	<b>21143 OVERVIEW .....</b>	<b>1</b>
1.1	General Description .....	2
1.2	Microarchitecture .....	3
<b>2.0</b>	<b>PINOUT .....</b>	<b>5</b>
2.1	Signal Reference Tables .....	7
2.2	Signal Reference Tables .....	9
2.3	Pin Tables.....	15
2.4	Signal Grouping by Function .....	17
<b>3.0</b>	<b>ELECTRICAL AND ENVIRONMENTAL SPECIFICATIONS.....</b>	<b>19</b>
3.1	Voltage Limit Ratings.....	19
3.2	Temperature Limit Ratings .....	19
3.3	Power Specifications .....	20
3.4	PCI Bus and CardBus Electrical Parameters .....	20
3.4.1	PCI and CardBus I/O Voltage Specifications .....	21
3.4.2	System Bus Reset.....	22
3.4.3	PCI and CardBus Clock Specifications .....	22
3.4.4	Other PCI and CardBus Signals.....	24
3.5	AUI and Twisted-Pair DC Specifications .....	25
3.6	Serial Interface Attachment Specifications .....	26
3.6.1	Serial Clock Timing .....	26
3.6.2	Internal SIA Mode AUI Timing—Transmit .....	27
3.6.3	Internal SIA Mode AUI Timing—Receive .....	28
3.6.4	Internal SIA Mode AUI Timing—Collision.....	28
3.6.5	Internal SIA Mode 10BASE-T Interface Timing—Transmit .....	29
3.6.6	Internal SIA Mode 10BASE-T Interface Timing—Receive .....	30
3.6.7	Internal SIA Mode 10BASE-T Interface Timing—Idle Link Pulse .....	31
3.7	MII Interface Specifications .....	32
3.8	MII/SYM Port Timing .....	32
3.8.1	MII/SYM 10/100-Mb/s and 10-Mb/s Timing—Transmit .....	32
3.8.2	MII/SYM 10/100-Mb/s Timing—Receive .....	34
3.8.3	SYM 10/100-Mb/s Timing—Signal Detect.....	35
3.8.4	MII 10/100-Mb/s Timing—Receive Error .....	35
3.8.5	MII 10/100-Mb/s Timing—Carrier Sense and Collision .....	36
3.9	Boot ROM and Serial ROM Port Specification .....	36
3.10	Boot ROM Port Timing .....	37
3.10.1	Boot ROM Read Timing .....	37
3.10.2	Boot ROM Write Timing.....	38
3.11	Serial ROM Port Timing.....	39
3.12	External Register Timing .....	39
3.13	Joint Test Action Group—Test Access Port .....	41
3.13.1	JTAG DC Specifications.....	41
3.13.2	JTAG Boundary-Scan Timing.....	42
<b>4.0</b>	<b>MECHANICAL SPECIFICATIONS .....</b>	<b>43</b>



## 1.0 21143 Overview

---

The Intel 21143 PCI/CardBus\* 10/100-Mb/s Ethernet LAN Controller (21143) supports the peripheral component interconnect (PCI) bus or CardBus. It provides a direct interface connection to the PCI bus and adapts easily to the CardBus and most other standard buses. The 21143 software interface and data structures are optimized to minimize the host CPU load and to allow for maximum flexibility in the buffer descriptor management. The 21143 contains large onchip FIFOs, so no additional onboard memory is required. The 21143 also provides an upgradable boot ROM interface.

In addition to the features listed on the title pages, the following features are also supported by the 21143:

### PCI and CardBus Features:

- Supports PCI and CardBus interfaces.
- Supports PCI/CardBus clock control through clkrun.
- Supports CardBus cstschg pin and Status Changed registers.
- Supports automatic loading of subvendor ID and CardBus card information structure (CIS) pointer from serial ROM to configuration registers.
- Supports storage of CardBus card information structure (CIS) in the serial ROM or the expansion ROM.
- Supports the advanced PCI/CardBus read multiple, read line, and write and invalidate commands.
- Supports an unlimited PCI/CardBus burst.

### Host Interface Features:

- Includes a powerful onchip direct memory access (DMA) with programmable burst size, providing low CPU utilization.
- Supports early interrupt on transmit and receive.
- Supports interrupt mitigation on transmit and receive.
- Supports big or little endian byte ordering for buffers and descriptors.
- Implements unique, patented intelligent arbitration between DMA channels to minimize underflow and overflow.
- Contains large independent receive and transmit FIFOs.

### Network Side Features:

- Supports three network ports: 10BASE-T (10 Mb/s), AUI (10 Mb/s), and MII/SYM (10/100 Mb/s).
- Contains a variety of flexible address filtering modes.
- Implements signal-detect filtering to avoid false detection of link with 100BASE-TX symbol interfaces.
- Enables automatic detection and correction of 10BASE-T receive polarity.
- Supports autodetection between 10BASE-T, AUI, and MII/SYM ports.
- Offers a unique, patented solution to Ethernet capture-effect problem.

- Supports full-duplex operation on both MII/SYM and 10BASE-T ports.
- Provides internal and external loopback capability on all network ports.
- Supports IEEE 802.3 and ANSI 8802-3 Ethernet standards.

**Other Features:**

- Provides MicroWire\* interface for serial ROM (1K and 4K EEPROM).
- Provides LED indications for various network activity.
- Implements test-access port (JTAG-compatible) with boundary-scan pins.
- Contains a 4-bit, general-purpose programmable register and corresponding I/O pins with the ability to generate interrupts from two general-purpose pins.

## 1.1 General Description

The 21143 is an Ethernet LAN controller for both 100-Mb/s and 10-Mb/s data rates, which provides a direct interface to the peripheral component interconnect (PCI) local bus or the CardBus. The 21143 interfaces to the host processor by using onchip command and status registers (CSRs) and a shared host memory area, set up mainly during initialization. This minimizes processor involvement in the 21143 operation during normal reception and transmission.

The 21143 is optimized for low power PCI/CardBus based systems and supports two types of power-management mechanisms. The main mechanism is based upon the OnNow architecture, which is required for PC 97 and PC 98. The alternative mechanism is based upon the older remote wake-up-LAN mechanism.

Large FIFOs allow the 21143 to efficiently operate in systems with longer latency periods. Bus traffic is also minimized by filtering out received runt frames and by automatically retransmitting collided frames without a repeated fetch from the host memory.

The 21143 provides three network ports: a 10BASE-T 10-Mb/s port, an attachment unit interface (AUI) 10-Mb/s port, and a media-independent/symbol interface (MII/SYM) 10/100-Mb/s port. The 10BASE-T port provides a direct Ethernet connection to the twisted-pair (TP) interface. The AUI port provides a direct Ethernet connection to the AUI.

The MII/SYM port supports two operational modes:

- MII mode—A full implementation of the MII standard
- SYM mode—Symbol interface to an external 100-Mb/s front-end decoder (ENDEC). In this mode the 21143 uses an onchip physical coding sublayer (PCS) and a scrambler/descrambler circuit to enable a low-cost 100BASE-T implementation.

The 21143 is capable of functioning in a full-duplex environment for the MII/SYM and 10BASE-T ports. The 21143 provides an upgradable boot ROM interface.

## 1.2 Microarchitecture

The following list describes the 21143 hardware components, and Figure 1 shows a block diagram of the 21143:

- PCI/CardBus interface—Includes all interface functions to the PCI and CardBus bus; handles all interconnect control signals; and executes DMA and I/O transactions
- Boot ROM port—Provides an interface to perform read and write operations to the boot ROM; supports accesses to bytes or longwords (32-bit); and provides the ability to connect an external 8-bit register to the boot ROM port
- Serial ROM port—Provides a direct interface to a MicroWire ROM for storage of the Ethernet address and system parameters
- General-purpose register—Enables software use for input or output functions and LEDs
- DMA—Contains independent receive and transmit controllers; handles data transfers between CPU memory and onchip memory
- FIFOs—Contains independent FIFOs for receive and transmit; supports automatic packet deletion on receive (runt packets or after a collision) and packet retransmission after a collision on transmit
- TxM—Handles all CSMA/CD<sup>1</sup> MAC<sup>2</sup> transmit operations, and transfers data from transmit FIFO to the ENDEC for transmission
- RxM—Handles all CSMA/CD MAC receive operations, and transfers the network data from the ENDEC to the receive FIFO
- SIA interface—Performs 10-Mb/s physical layer network operations; implements the AUI and 10BASE-T functions, including the Manchester encoder and decoder functions
- NWAY—Implements the IEEE 802.3 Auto-Negotiation algorithm
- Physical coding sublayer—Implements the encoding and decoding sublayer of the 100BASE-TX (CAT5) specification, including the squelch feature
- Scrambler/descrambler—Implements the twisted-pair physical layer medium dependent (TP-PMD) scrambler/descrambler scheme for 100BASE-TX
- Three network interfaces—An AUI interface, a 10BASE-T interface, and an MII/SYM interface provide a full MII signal interface and direct interface to the 100-Mb/s ENDEC for CAT5
- Wake-up-controller—Enables power-management control compliant with the ACPI and remote power-up capabilities using the remote wake-up-LAN mechanism

---

1. Carrier-sense multiple access with collision detection.

2. Media access control.

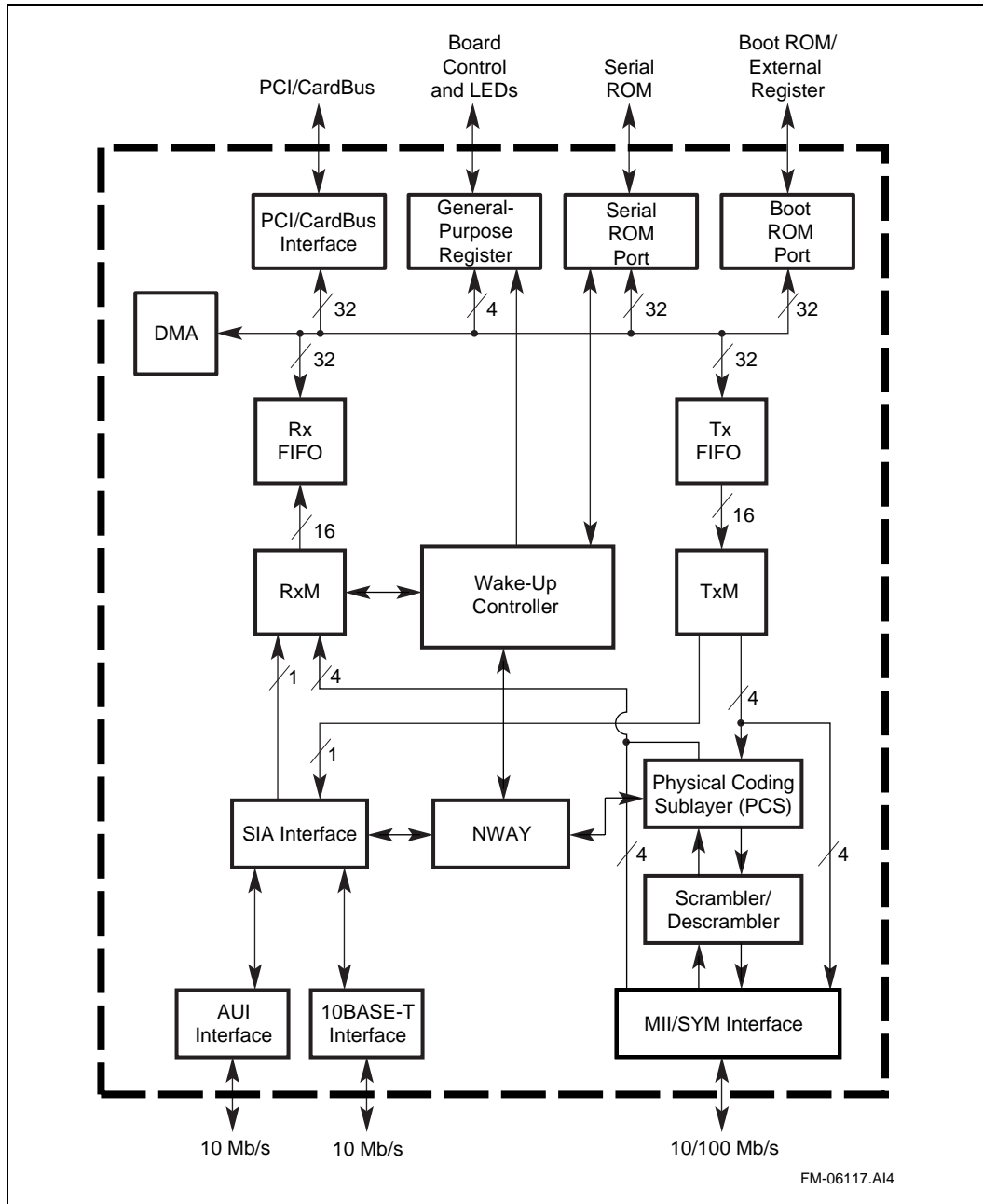

Figure 1. 21143 Block Diagram



## 2.0 Pinout

---

The 21143 is offered in two package styles: a 144-pin low-profile quad flat pack (LQFP) and a 144-pin metric quad flat pack (MQFP). The tables in this section provide a description of the pins and their respective signal definitions.

Table 1 lists the tables in this section. Figure 2 shows the 21143 pinout for both the LQFP and MQFP package types

**Table 1. Index to Pinout Tables**

For this information...	Refer to...
Logic signals	Table 2
Power pins	Table 3
Functional signals description	Table 4
Input pins	Table 5
Output pins	Table 6
Input/output pins	Table 7
Open drain pins	Table 8
Signal functions	Table 9

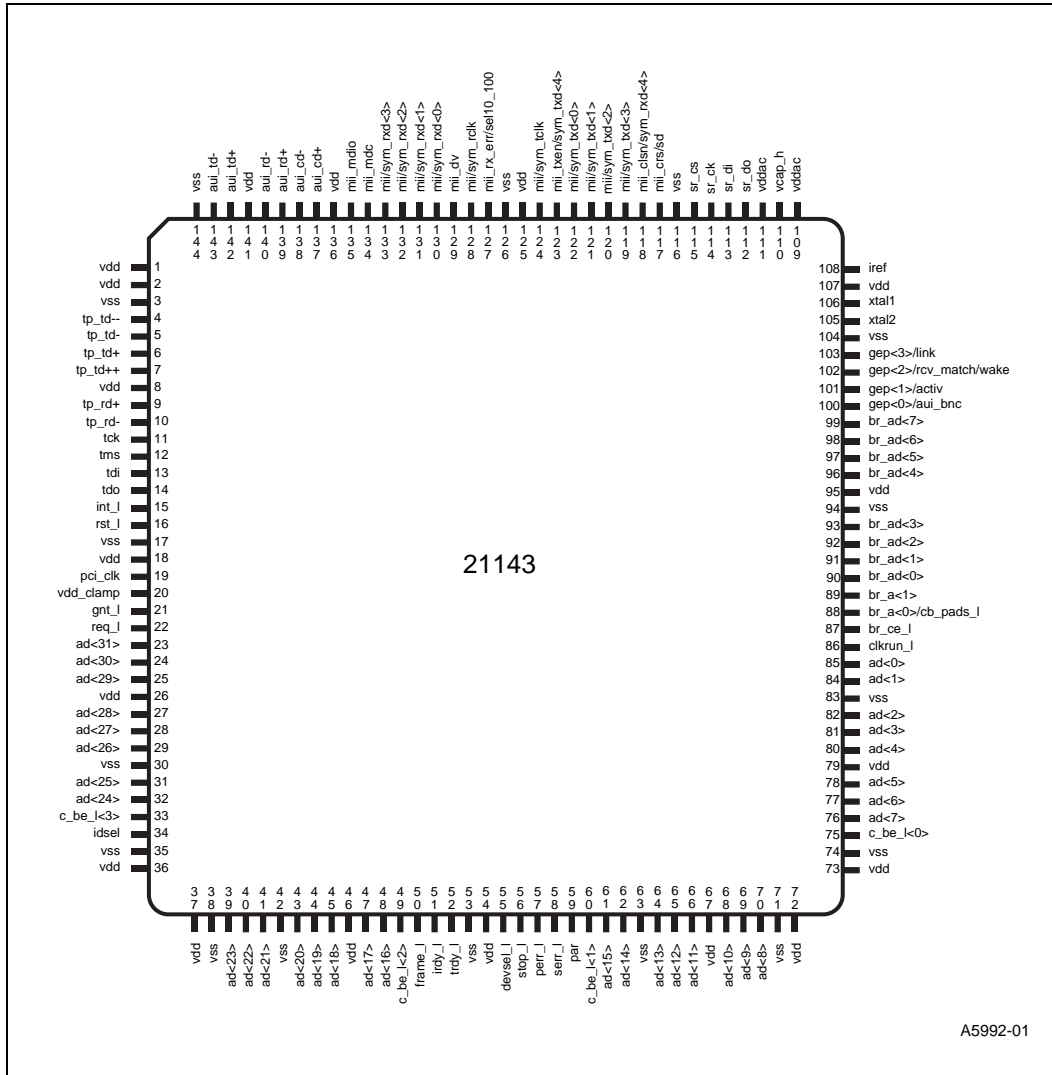

Figure 2. 21143 Pinout Diagram (Top View)

## 2.1 Signal Reference Tables

Table 2 provides an alphabetical list of the 21143 logic names and their pin numbers. Table 3 provides a list of the 21143 power pin numbers.

Table 2. Logic Signals (Sheet 1 of 2)

Signal	Pin Number	Signal	Pin Number	Signal	Pin Number
ad<0>	85	au_i_rd-	140	mii_mdc	134
ad<1>	84	au_i_rd+	139	mii_mdio	135
ad<2>	82	au_i_td-	143	mii/sym_rclk	128
ad<3>	81	au_i_td+	142	mii_rx_err/sel10_100	127
ad<4>	80	br_a<0>/ cb_pads_l	88	mii/sym_rxd<0>	130
ad<5>	78	br_a<1>	89	mii/sym_rxd<1>	131
ad<6>	77	br_ad<0>	90	mii/sym_rxd<2>	132
ad<7>	76	br_ad<1>	91	mii/sym_rxd<3>	133
ad<8>	70	br_ad<2>	92	mii/sym_tclk	124
ad<9>	69	br_ad<3>	93	mii/sym_txd<0>	122
ad<10>	68	br_ad<4>	96	mii/sym_txd<1>	121
ad<11>	66	br_ad<5>	97	mii/sym_txd<2>	120
ad<12>	65	br_ad<6>	98	mii/sym_txd<3>	119
ad<13>	64	br_ad<7>	99	mii_txen/sym_txd<4>	123
ad<14>	62	br_ce_l	87	par	59
ad<15>	61	c_be_l<0>	75	pci_clk	19
ad<16>	48	c_be_l<1>	60	perr_l	57
ad<17>	47	c_be_l<2>	49	req_l	22
ad<18>	45	c_be_l<3>	33	rst_l	16
ad<19>	44	clkrun_l	86	serr_l	58
ad<20>	43	devsel_l	55	sr_ck	114
ad<21>	41	frame_l	50	sr_cs	115
ad<22>	40	gep<0>/ au_i_bnc	100	sr_di	113
ad<23>	39	gep<1>/activ	101	sr_do	112
ad<24>	32	gep<2>/ rcv_match/ wake	102	stop_l	56
ad<25>	31	gep<3>/link	103	tck	11
ad<26>	29	gnt_l	21	tdi	13
ad<27>	28	idsel	34	tdo	14
ad<28>	27	int_l	15	tms	12
ad<29>	25	irdy_l	51	tp_rd-	10
ad<30>	24	iref	108	tp_rd+	9
ad<31>	23	mii_clsn/ sym_rxd<4>	118	tp_td-	5
au_i_cd-	138	mii_crs/sd	117	tp_td- -	4
au_i_cd+	137	mii_dv	129	tp_td+	6

**Table 2. Logic Signals (Sheet 2 of 2)**

Signal	Pin Number	Signal	Pin Number	Signal	Pin Number
tp_td+ +	7	trdy_l	52	vcap_h	110
xtal1	106	xtal2	105	—	—

**Table 3. Power Pins**

Signal	Pin Number	Signal	Pin Number
vdd (3.3 V)	1, 2, 8, 18, 26, 36, 37, 46, 54, 67, 72, 73, 79, 95, 107, 125, 136, 141	vss (GND)	3, 17, 30, 35, 38, 42, 53, 63, 71, 74, 83, 94, 104, 116, 126, 144
vddac (3.3 V)	109, 111	—	—
vdd_clamp (5 V or 3.3 V)	20	—	—

## 2.2 Signal Reference Tables

The functional grouping of each pin is listed in Section 2.4.

The following terms describe the 21143 pinout:

- Address phase

Address and appropriate bus commands are driven during this cycle.

- Data phase

Data and the appropriate byte enable codes are driven during this cycle.

- $\_l$

All pin names with the  $\_l$  suffix are asserted low.

The following pins in Table 4 have an internal pull-up:

tms  
tdi  
br\_ce\_l  
sr\_do  
mii/sym\_tclk

Pin sr\_cs has an internal pull-down.

Table 4 uses the following abbreviations:

I = Input  
O = Output  
I/O = Input/output  
O/D = Open drain  
P = Power

Table 4 provides a functional description of each of the 21143 signals. These signals are listed alphabetically.

**Table 4. Functional Description of 21143 Signals (Sheet 1 of 6)**

Signal	Type	Pin Number	Description
ad<31:0>	I/O	23, 24, 25, 27, 28, 29, 31, 32, 39, 40, 41, 43, 44, 45, 47, 48, 61, 62, 64, 65, 66, 68, 69, 70, 76, 77, 78, 80, 81, 82, 84, 85	32-bit PCI address and data lines. Address and data bits are multiplexed on the same pins. During the first clock cycle of a transaction, the address bits contain a physical address (32 bits). During subsequent clock cycles, these same lines contain 32 bits of data. A 21143 bus transaction consists of an address phase followed by one or more data phases. The 21143 supports both read and write bursts (in master operation only). Little and big endian byte ordering can be used.
au_i_cd-	I	138	Attachment unit interface receive collision differential negative data.
au_i_cd+	I	137	Attachment unit interface receive collision differential positive data.
au_i_rd-	I	140	Attachment unit interface receive differential negative data.
au_i_rd+	I	139	Attachment unit interface receive differential positive data.
au_i_td-	O	143	Attachment unit interface transmit differential negative data.
au_i_td+	O	142	Attachment unit interface transmit differential positive data.
br_a<0>/ cb_pads_l	O	88	Boot ROM address line bit 0. In a 256KB configuration, this pin also carries in two consecutive address cycles, boot ROM address bits 16 and 17.  This pin also determines the type of signals to use for the PCI/ CardBus* output pins, either PCI or CardBus. By default, this pin selects PCI signaling. To select CardBus signaling, this pin must be connected to a pull-down resistor.
br_a<1>	O	89	Boot ROM address line bit 1. This pin also latches the boot ROM address and control lines by the two external latches.
br_ad<7:0>	I/O	90, 91, 92, 93, 96, 97, 98, 99	Boot ROM address and data multiplexed lines bits 7 through 0. In two consecutive address cycles, these lines contain the boot ROM address pins 7 through 2, oe_l and we_l in the first cycle; and these lines contain boot ROM address pins 15 through 8 in the second cycle. During the data cycle, bits 7 through 0 contain data.
br_ce_l	O	87	Boot ROM or external register chip enable.
c_be_l<3:0>	I/O	33, 49, 60, 75	Bits 0 through 3 of the bus command and byte enable lines. Bus command and byte enable are multiplexed on the same PCI pins.  During the address phase of the transaction, these 4 bits provide the bus command.  During the data phase, these 4 bits provide the byte enable. The byte enable determines which byte lines carry valid data. For example, bit 0 applies to byte 0, and bit 3 applies to byte 3.
clkrun_l	I/O O/D	86	PCI/CardBus clock run indication. The host system asserts this signal to indicate normal operation of the clock. The host system deasserts clkrun_l when the clock is going to be stopped or slowed down to a nonoperational frequency.  If the clock is needed by the 21143, the 21143 asserts clkrun_l, requesting normal clock operation to be maintained or restored. Otherwise, the 21143 allows the system to stop the clock. If this pin is not connected to the PCI/CardBus bus, it should be connected to a pull-down resistor.

Table 4. Functional Description of 21143 Signals (Sheet 2 of 6)

Signal	Type	Pin Number	Description
devsel_I	I/O	55	Device select is asserted by the target of the current bus access. When the 21143 is the initiator of the current bus access, it expects the target to assert devsel_I within 5 bus cycles, confirming the access. If the target does not assert devsel_I within the required bus cycles, the 21143 aborts the cycle. To meet the timing requirements, the 21143 asserts this signal in a medium speed (within 2 bus cycles).
frame_I	I/O	50	The frame_I signal is driven by the bus master to indicate the beginning and duration of an access. The frame_I signal asserts to indicate the beginning of a bus transaction. While frame_I is asserted, data transfers continue. The frame_I signal deasserts to indicate that the next data phase is the final data phase transaction.
gep<0>/ aui_bnc	I/O	100	This pin can be configured by software to be: <ul style="list-style-type: none"> <li>A general-purpose pin that performs either input or output functions. This general-purpose pin can provide an interrupt when functioning as an input.</li> <li>A control pin that provides an AUI (10BASE5) or BNC (10BASE2) select line.</li> </ul> This control pin is mainly used to enable the external BNC transceiver in 10BASE2 mode. When set, the 10BASE5 mode is selected. When reset, the 10BASE2 mode is selected. <p><b>NOTE:</b> This control pin is internally forced to the aui_bnc function when the 21143 is in remote wake-up-LAN mode.</p>
gep<1>/activ	I/O	101	This pin can be configured by software to be: <ul style="list-style-type: none"> <li>A general-purpose pin that performs either input or output functions. This general-purpose pin can provide an interrupt when functioning as an input.</li> <li>A status pin that provides an LED that indicates either receive or transmit activity.</li> </ul>
gep<2>/ rcv_match/ wake	I/O	102	This pin can be configured by software to be: <ul style="list-style-type: none"> <li>A general-purpose pin that performs either input or output functions.</li> <li>A status pin that provides an LED that indicates a receive packet has passed address recognition.</li> </ul> If the PME_Enable bit (Func0_HwOptions<3>) in the serial ROM is set, this pin is forced to function as a wake-up event pin that can be connected to pin pme# of the PCI connector or pin cstschg of the CardBus connector. When the 21143 is in remote wake-up-LAN mode, this pin is used as an indicator that a Magic Packet* has been successfully detected. When this pin is in a wake function, bit MiscHwOptions<1> in the serial ROM determines the polarity. The PME function takes precedence over the Magic Packet indication function.
gep<3>/link	I/O	103	This pin can be configured by software to be: <ul style="list-style-type: none"> <li>A general-purpose pin that performs either input or output functions. When configured as an input pin in OnNow mode, this pin functions as link status. When used with an MII PHY device, this pin should be connected to the MII PHY link indication pin (the 21143 interprets link-pass when this pin is high). This pin should not be left unconnected if it is configured as an input in D1, D2 or D3 power states.</li> <li>A status pin that provides an LED to indicate:               <ul style="list-style-type: none"> <li>–Network link integrity state for 10BASE-T or 100BASE-TX if Func1_Hw_Options&lt;8&gt; is cleared in the SROM.</li> <li>–Both network activity and network link integrity state if Func1_Hw_Options&lt;8&gt; is set in the SROM.</li> </ul> </li> </ul>

Table 4. Functional Description of 21143 Signals (Sheet 3 of 6)

Signal	Type	Pin Number	Description
gnt_l	I	21	Bus grant asserts to indicate to the 21143 that access to the bus is granted.
idsel	I	34	Initialization device select asserts to indicate that the host is issuing a configuration cycle to the 21143.
int_l	O/D	15	Interrupt request asserts when one of the appropriate bits of CSR5 sets and causes an interrupt, provided that the corresponding mask bit in CSR7 is not asserted. Interrupt request deasserts by writing a 1 into the appropriate CSR5 bit. If more than one interrupt bit is asserted in CSR5 and the host does not clear all input bits, the 21143 deasserts int_l for one cycle to support edge-triggered systems.
iref	I	108	Current reference input for the analog phase-locked loop logic.
irdy_l	I/O	51	Initiator ready indicates the bus master's ability to complete the current data phase of the transaction. A data phase is completed on any rising edge of the clock when both irdy_l and target ready trdy_l are asserted. Wait cycles are inserted until both irdy_l and trdy_l are asserted together. When the 21143 is the bus master, it asserts irdy_l during write operations to indicate that valid data is present on the 32-bit ad lines. During read operations, the 21143 asserts irdy_l to indicate that it is ready to accept data.
mii_clsn/ sym_rxd<4>	I	118	In MII mode (CSR6<18>=1, CSR6<23>=0), this pin functions as the collision detect. When the external physical layer protocol (PHY) device detects a collision, it asserts this pin. In SYM mode (CSR6<18>=1, CSR6<23>=1), this pin functions as receive data. This line along with the four receive lines (sym_rxd<3:0>) provides five parallel data lines in symbol form. This data is controlled by an external physical layer medium-dependent (PMD) device and should be synchronized to the sym_rclk signal.
mii_crs/sd	I	117	In MII mode this pin functions as the carrier sense and is asserted by the PHY when the media is active. In SYM mode this pin functions as the signal detect indication. It is controlled by an external PMD device.
mii_dv	I	129	Data valid is asserted by an external PHY when receive data is present on the mii_rxd lines and is deasserted at the end of the packet. This signal should be synchronized with the mii_rclk signal.
mii_mdc	O	134	MII management data clock is sourced by the 21143 to the PHY devices as a timing reference for the transfer of information on the mii_mdio signal.
mii_mdio	I/O	135	MII management data input/output transfers control information and status between the PHY and the 21143.
mii/sym_rclk	I	128	Supports either the 25-MHz or 2.5-MHz receive clock. This clock is recovered by the PHY.
mii_rx_err/ sel10_100	I/O	127	When used with an MII PHY device (CSR6<18>=1, CSR6<23>=0), this pin functions as receive error input. It is asserted when a data decoding error is detected by an external PHY device. This signal is synchronized to mii_rclk and can be asserted for a minimum of one receive clock. When asserted during a packet reception, it sets the cyclic redundancy check (CRC) error bit in the receive descriptor (RDES0). When used with a SYM PHY device (CSR6<23>=1), this pin functions as select 10/100 output. The signal sel10_100 equals 1 when the 21143 is in 100-Mb/s SYM mode (CSR6<18>=1) and equals 0 when the 21143 is in 10BASE-T/AUI mode (CSR6<18>=0).



**Table 4. Functional Description of 21143 Signals (Sheet 4 of 6)**

Signal	Type	Pin Number	Description
mii/ sym_rxd<3:0>	I	130, 131, 132,133,	Four parallel receive data lines. This data is driven by an external PHY that attached the media and should be synchronized with the mii_rclk signal.
mii/sym_tclk	I	124	Supports the 25-MHz or 2.5-MHz transmit clock supplied by the external PMD device. This clock should always be active.
mii/ sym_txd<3:0>	O	119, 120, 121, 122	Four parallel transmit data lines. This data is synchronized to the assertion of the mii_tclk signal and is latched by the external PHY on the rising edge of the mii_tclk signal.
mii_txen/ sym_txd<4>	O	123	In MII mode (CSR6<18>=1, CSR6<23>=0), this pin functions as transmit enable. It indicates that a transmission is active on the MII port to an external PHY device. In SYM mode, this pin functions as transmit data. This line along with the four data transmit lines (sym_txd<3:0>) provides five parallel data lines in symbol form. The data is synchronized to the rising edge of the sym_tclk signal.
par	I/O	59	Parity is calculated by the 21143 as an even parity bit for the 32-bit ad and 4-bit c_be_l lines. During address and data phases, parity is calculated on all the ad and c_be_l lines whether or not any of these lines carry meaningful information.
pci_clk	I	19	The clock provides the timing for the 21143 related PCI bus transactions. All the bus signals are sampled on the rising edge of pci_clk. The supported range of the clock frequency is 20 MHz to 33 MHz.
perr_l	I/O	57	Parity error asserts when a data parity error is detected. The 21143 asserts perr_l when a data parity error is detected in either a master-read or a slave-write operation. When the 21143 is the bus master and a parity error is detected, the 21143 asserts both CSR5 bit 13 (fatal bus error) and CFCS bit 24 (data parity report). Next, it completes the current data burst transaction, then stops operation. After the host clears the fatal error bit in CSR5, the 21143 continues its operation.
req_l	O	22	Bus request is asserted by the 21143 to indicate to the bus arbiter that it wants to use the bus.
rst_l	I	16	Resets the 21143 to its initial state. This signal must be asserted for at least 10 active PCI clock cycles. When in the reset state, all PCI output pins are put into tristate and all PCI O/D signals are floated.
serr_l	O/D	58	If an address parity error is detected and CFCS bit 8 (serr_l enable) is enabled, 21143 asserts both serr_l (system error) and CFCS bit 30 (signal system error). When an address parity error is detected, system error asserts two clocks after the failing address.
sr_ck	O	114	Serial ROM clock signal. This pin provides a serial clock output for the serial ROM.
sr_cs	O	115	Serial ROM chip-select signal. This pin provides a chip select for the serial ROM.
sr_di	O	113	Serial ROM data-in signal. This pin serially shifts the write data from the 21143 to the serial ROM device.
sr_do	I	112	Serial ROM data-out signal. This pin serially shifts the read data from the serial ROM device to the 21143.

Table 4. Functional Description of 21143 Signals (Sheet 5 of 6)

Signal	Type	Pin Number	Description
stop_l	I/O	56	Stop indicator indicates that the current target is requesting the bus master to stop the current transaction. The 21143 responds to the assertion of stop_l when it is the bus master, either to disconnect, retry, or abort.
tck	I	11	JTAG clock shifts state information and test data into and out of the 21143 during JTAG test operations. If the JTAG port is unused, this pin should be connected to vss.
tdi	I	13	JTAG data in is used to serially shift test data and instructions into the 21143 during JTAG test operations.
tdo	O	14	JTAG data out is used to serially shift test data out of the 21143 during JTAG test operations.
tms	I	12	JTAG test mode select controls the state operation of JTAG testing in the 21143.
tp_rd-	I	10	Twisted-pair negative differential receive data from the twisted-pair lines.
tp_rd+	I	9	Twisted-pair positive differential receive data from the twisted-pair lines.
tp_td- tp_td- -	O O	5 4	Twisted-pair negative differential transmit data. The positive and negative differential transmit data outputs are combined resistively outside the 21143 with equalization to compensate for intersymbol interference on the twisted-pair medium.
tp_td+ tp_td+ +	O O	6 7	Twisted-pair positive differential transmit data. The positive and negative differential transmit data outputs are combined resistively outside the 21143 with equalization to compensate for intersymbol interference on the twisted-pair medium.
trdy_l	I/O	52	Target ready indicates the target agent's ability to complete the current data phase of the transaction. A data phase is completed on any clock when both trdy_l and irdy_l are asserted. Wait cycles are inserted until both irdy_l and trdy_l are asserted together. When the 21143 is the bus master, target ready is asserted by the bus slave on the read operation, which indicates that valid data is present on the ad lines. During a write cycle, it indicates that the target is prepared to accept data.
vcap_h	I	110	Capacitor input for analog phase-locked loop logic.
vdd	P	1, 2, 8, 18, 26, 36, 37, 46, 54, 67, 72, 73, 79, 95, 107, 125, 136, 141	3.3-V supply input. These pins should be connected to the auxiliary power, if such power exists. Otherwise, these pins should be connected to the main power.
vddac	P	109, 111	Supplies +3.3-V input for analog phase-locked loop logic.
vdd_clamp	P	20	Supplies +5-V or +3.3-V reference for clamp logic. This pin is also used to identify the lack of main power when the auxiliary power is on. This pin should be connected to the main power.
vss	P	3, 17, 30, 35, 38, 42, 53, 63, 71, 74, 83, 94, 104, 116, 126, 144	Ground pins.
xtal1	I	106	20-MHz crystal input, or crystal oscillator input. This pin should always be provided with a clock.

**Table 4. Functional Description of 21143 Signals (Sheet 6 of 6)**

Signal	Type	Pin Number	Description
xtal2	O	105	Crystal feedback output pin used for crystal connections only. If this pin is unused, then it should be unconnected.

## 2.3 Pin Tables

This section contains four types of pin tables:

- Table 5 lists the input pins.
- Table 6 lists the output pins.
- Table 7 lists the input/output pins.
- Table 8 lists the open drain pins.

**Table 5. Input Pins**

Signal	Active Level	Signal	Active Level
au_i_cd-	Low	mii/sym_tclk	—
au_i_cd+	High	pci_clk	—
au_i_rd-	—	rst_l	Low
au_i_rd+	—	sr_do	—
gnt_l	Low	tck	—
idsel	High	tdi	—
iref	—	tms	—
mii_clsn/sym_rxd<4>	High for mii_clsn, — for sym_rxd<4>	tp_rd-	—
mii_crs/sd	High	tp_rd+	—
mii_dv	High	vcap_h	—
mii/sym_rclk	—	xtal1	—
mii/sym_rxd<3:0>	—	—	—

**Table 6. Output Pins**

Signal	Active Level	Signal	Active Level
au_i_td-	—	sr_cs	High
au_i_td+	—	sr_di	—
br_a<1>	High	tdo	—
br_ce_l	Low	tp_td-	—
mii_mdc	—	tp_td- -	—
mii/sym_txd<3:0>	—	tp_td+	—
mii_txen/sym_txd<4>	High for mii_txen, — for sym_txd<4>	tp_td+ +	—
req_l	Low	xtal2	—
sr_ck	—	—	—

Table 7. Input/Output Pins

Signal	Active Level	Signal	Active Level
ad<31:0>	—	gep<2>/rcv_match/wake	— for gep<2>, high for rcv_match, — <sup>a</sup> for wake
br_a<0>/cb_pads_l	High for br_a<0>, low for cb_pads_l	gep<3>/link	— for gep<3>, high for link
br_ad<7:0>	—	irdy_l	Low
clkrun_l	Low	mii_mdio	—
c_be_l<3:0>	Low	mii_rx_err/sel10_100	High for mii_rx_err, — for sel10_100
devsel_l	Low	par	—
frame_l	Low	perr_l	Low
gep<0>/aui_bnc	—	stop_l	Low
gep<1>/activ	— for gep<1>, high for activ	trdy_l	Low

a. The active level is controlled by bit MiscHwOptions<1> (PME\_STSCHG) in the serial ROM.

Table 8. Open Drain Pins

Signal	Active Level	Signal	Active Level
int_l	Low	serr_l	Low

## 2.4 Signal Grouping by Function

Table 9 lists the signals according to their interface function.

**Table 9. Signal Functions (Sheet 1 of 2)**

Interface	Function	Signals
PCI/CardBus	Address and data	ad<31:0>, par
	Arbitration	gnt_l, req_l
	Bus command and byte enable	c_be_l<3:0>
	Device select	devsel_l, idsel
	Error reporting	perr_l, serr_l
	Interrupt	int_l
	System	pci_clk, rst_l
	Control signals	frame_l, stop_l, irdy_l, trdy_l
	Power-management status	wake
	Clock status	clkrun_l
	Pad select	cb_pads_l
MII/SYM network port	Transmit data lines	mii/sym_txd<3:0>
	Receive data lines	mii/sym_rxd<3:0>
	Transmit, receive clocks	mii/sym_tclk, mii/sym_rclk
	Transmit enable	mii_txen
	Collision detect	mii_clsn
	MII error reporting	mii_rx_err
	Data control	mii_dv, mii_crs
	MII management data clock	mii_mdc
	MII management data input/output	mii_mdio
	Signal detection	sd
	SYM mode data lines	sym_rxd<4>, sym_txd<4>
	SYM mode 10/100 select	sel10_100
	Test access port	JTAG test operations
Serial ROM port	Serial ROM	sr_ck, sr_cs, sr_di, sr_do
Boot ROM port	ROM interface	br_a<1:0>, br_ad<7:0>, br_ce_l
Power	3.3-V or 5.0-V supply input	vdd_clamp
	3.3-V supply input	vdd, vddac
	Ground	vss
General-purpose port and LEDs	General-purpose pins	gep<3:0>
	LED indicators	activ, rcv_match, link
	10BASE5/10BASE2 select	au_i_bnc

**Table 9. Signal Functions (Sheet 2 of 2)**

Interface	Function	Signals
Network connection	Analog phase-locked loop logic	iref, vcap_h
	AUI collision data	au_i_cd-, au_i_cd+
	AUI transmit and receive data	au_i_rd-, au_i_rd+, au_i_td-, au_i_td+
	Crystal oscillator	xtal1, xtal2
	Twisted-pair transmit and receive data	tp_rd-, tp_rd+, tp_td-, tp_td- -, tp_td+, tp_td+ +

## 3.0 Electrical and Environmental Specifications

---

This section contains the electrical and environmental specifications for the 21143.

**Caution:** Stresses greater than the maximum or less than the minimum ratings can cause permanent damage to the 21143. Exposure to the maximum or minimum ratings for extended periods of time lessen the reliability of the 21143.

### 3.1 Voltage Limit Ratings

Table 10 lists the voltage limit ratings.

**Table 10. Voltage Limit Ratings**

Parameter	Minimum	Maximum
Power supply voltage	3.0 V	3.6 V
vdd_clamp (5.0 V)	4.75 V	5.25 V
vdd_clamp (3.3 V) <sup>1</sup>	3.0 V	3.6 V
ESD protection voltage	—	2000 V

<sup>1</sup> In the 3.3-V signaling environment, vdd\_clamp must not be greater than vdd + 0.3 V.

### 3.2 Temperature Limit Ratings

Table 11 lists the temperature limit ratings.

**Table 11. Temperature Limit Ratings**

Parameter	Minimum	Maximum
Storage temperature	-55°C (-67°F)	125°C (257°F)
Operating temperature	0°C (32°F)	70°C (158°F)

### 3.3 Power Specifications

The values in Table 12 are based on a PCI or CardBus\* clock frequency of 33 MHz and a network data rate of 10/100 Mb/s for MII for legacy power-saving modes.

**Table 12. Legacy Power-Saving Modes Specification**

Mode	IDD <sup>1</sup> (mA)	Power <sup>1</sup> (mW)	IDD <sup>2</sup> (mA)	Power <sup>2</sup> (mW)
After power-up	54	178	—	—
Normal	150	495	230	828
Snooze	85	280	145	522
Sleep	25	82	115	414

<sup>1</sup>. Typical: **vdd** = 3.3 V, Ta = 25°C

<sup>2</sup>. Maximum: **vdd** = 3.6 V, Ta = 0°C

The values in Table 13 are based on a PCI clock frequency of 25 MHz, vdd at 3.3 V, Ta at 25°C, and a network data rate of 10/100 Mb/s for ACPI modes.

**Table 13. ACPI Modes Power Specification**

Condition	IDD (mA)	Typical Power Consumption (mW)
D0 normal, full network activity	145 mA	479 mW
D0 snooze, 50% network activity	130 mA	429 mW
D1 snooze, 50% network activity	118 mA	389 mW
D2 snooze, PCI clock running	109 mA	356 mW
D3 snooze, PCI clock stopped	102 mA	337 mW
After power-up, CardBus pads	51 mA	168 mW

### 3.4 PCI Bus and CardBus Electrical Parameters

This section describes the PCI Bus and CardBus characteristics for the 21143.



### 3.4.1 PCI and CardBus I/O Voltage Specifications

The 21143 meets the I/O voltage specifications listed in Table 14 and Table 15.

**Table 14. I/O Voltage Specifications for 5.0-V Levels**

Symbol	Parameter	Condition	Minimum	Maximum
$V_{ih}$	Input high voltage	—	2.0 V	vdd_clamp + 0.5 V
$V_{il}$	Input low voltage	—	-0.5 V	0.8 V
$I_i^1$	Input leakage current	$0.5\text{ V} < V_{in} < 2.7\text{ V}$	—	$\pm 10\ \mu\text{A}$
$V_{oh}$	Output high voltage	$I_{out} = -2\text{ mA}$	2.4 V	—
$V_{ol}^2$	Output low voltage	$I_{out} = 3\text{ mA}, 6\text{ mA}$	—	0.55 V
Cap <sup>3</sup>	Pin capacitance	—	5 pF	8 pF

1. Input leakage currents include high-impedance output leakage for all bidirectional buffers with tristate outputs.
2. Signals without pull-up resistors must have 3-mA low output current. Signals requiring pull-up resistors (including frame\_1, trdy\_1, irdy\_1, devsel\_1, stop\_1, serr\_1, and perr\_1) must have 6 mA.
3. Parameter design guarantee.

**Table 15. I/O Voltage Specifications for 3.3-V Levels**

Symbol	Parameter	Condition	Minimum	Maximum
$V_{ih}$	Input high voltage	—	$0.475 \cdot \text{vdd\_clamp}$	vdd_clamp + 0.5 V
$V_{il}$	Input low voltage	—	-0.5 V	$0.325 \cdot \text{vdd\_clamp}$
$I_i^1$	Input leakage current	$0.0\text{ V} < V_{in} < \text{vdd\_clamp}$	—	$\pm 70\ \mu\text{A}$
$V_{oh}$	Output high voltage	$I_{out} = -500\ \mu\text{A}$	$0.9 \cdot \text{vdd\_clamp}$	—
$V_{ol}$	Output low voltage	$I_{out} = 1500\ \mu\text{A}$	—	$0.1 \cdot \text{vdd\_clamp}$
Cap <sup>2</sup>	Pin capacitance	—	5 pF	8 pF

1. Input leakage currents include high-impedance output leakage for all bidirectional buffers with tristate outputs.
2. Parameter design guarantee.

### 3.4.2 System Bus Reset

System bus (PCI or CardBus) reset (rst\_l) is an asynchronous signal that must be active for at least 10 system bus (PCI or CardBus) clock (pci\_clk) cycles. Figure 3 shows the reset timing characteristics, and Table 16 lists the reset signal limits.

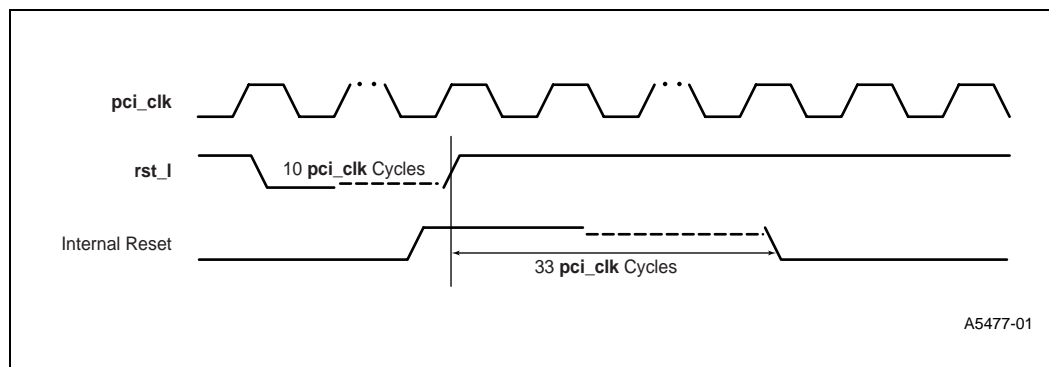

Figure 3. Reset Timing Diagram

Table 16. Reset Timing Parameters

Symbol	Parameter	Minimum	Maximum	Condition
Trst	rst_l pulse width	10*pci_clk	Not applicable	pci_clk active

### 3.4.3 PCI and CardBus Clock Specifications

The clock frequency range<sup>1</sup> for PCI and CardBus is between 20 MHz and 33 MHz. Figure 4 shows the PCI and CardBus clock specification timing characteristics and the required measurement points for both the 5.0-V and 3.3-V signaling environments. Table 17 lists the frequency-derived clock specifications.

1. The PCI and CardBus clock frequency is from dc to 33 MHz; network operational with the PCI or CardBus clock from 20 MHz to 33 MHz.

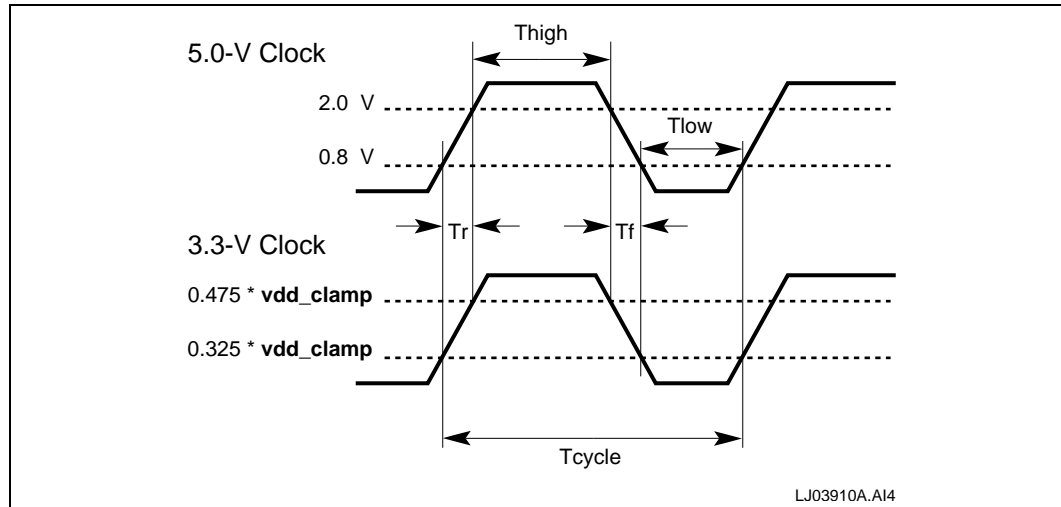

Figure 4. PCI and CardBus Clock Specification Timing Diagram

Table 17. PCI and CardBus Clock Timing Specifications

Symbol	Parameter	Minimum	Maximum
Tcycle	Cycle time	30 ns	50 ns
Thigh	pci_clk high time	11 ns	—
Tlow	pci_clk low time	11 ns	—
Tr/Tf <sup>1</sup>	pci_clk slew rate	1 V/ns	4 V/ns

<sup>1</sup>. Rise and fall times are specified in terms of the edge rate measured in V/ns. Parameter design guarantee.

### 3.4.4 Other PCI and CardBus Signals

Figure 5 shows the timing diagram characteristics for other PCI and CardBus signals and Table 18 lists their timing specifications. This timing is identical to the timing for the general-purpose register signals.

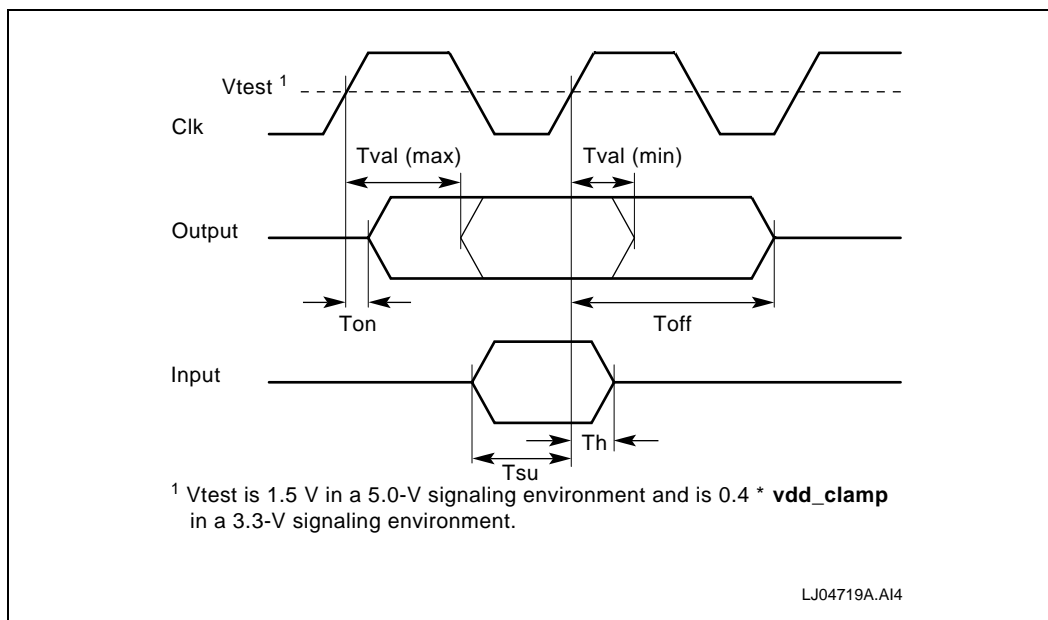

Figure 5. Timing Diagram for Other PCI and CardBus Signals

Table 18. Other PCI and CardBus Signals' Timing Specifications

Symbol	Parameter	Minimum	Maximum
Tval <sup>1</sup>	clk-to-signal valid delay <sup>2</sup>	2 ns	11 ns
Ton <sup>1</sup>	Float-to-active delay from clk <sup>3</sup>	2 ns	—
Toff <sup>4</sup>	Active-to-float delay from clk	—	28 ns
Tsu <sup>4</sup>	Input signal valid setup time before clk	7 ns	—
Th	Input signal hold time from clk	0 ns	—
Slewr, Slew <sup>f4</sup>	Output rise and fall slew rate <sup>5</sup>	1 V/ns	4 V/ns
Slewr, Slew <sup>f4</sup>	Output rise and fall slew rate <sup>6</sup>	0.25 V/ns	1 V/ns

<sup>1</sup>. Load for this measurement is as specified in *PCI Local Bus Specification*, Revision 2.0 and *PCI Local Bus Specification*, Revision 2.1.

<sup>2</sup>. Valid delays for PCI, selected by default when pin cb\_pad\_l is not pulled down externally.

<sup>3</sup>. Valid delays for CardBus, selected by default when pin cb\_pad\_l is pulled down externally.

<sup>4</sup>. Parameter design guarantee.

<sup>5</sup>. Slew rate for PCI, selected by default when pin cb\_pad\_l is not pulled down externally.

<sup>6</sup>. Slew rate for CardBus, selected when pin cb\_pad\_l is pulled down externally.

### 3.5 AUI and Twisted-Pair DC Specifications

Table 19 lists the dc specifications for the AUI and twisted-pair parts of the SIA.

**Table 19. AUI and Twisted-Pair DC Specifications**

Symbol	Definition	Condition	Minimum	Maximum	Unit
<b>AUI Pins</b>					
$V_{od}$	Transmit differential output voltage (aui_td±)	78 $\Omega$ termination	$\pm 550$	$\pm 1200$	mV
$V_{odi}^1$	Transmit differential output idle voltage (aui_td±)	78 $\Omega$ termination	-40	+40	mV
$I_{odi}^1$	Transmit differential output idle current (aui_td±)	78 $\Omega$ termination	-1	+1	mA
$V_{asq}^{+1}$	Differential positive squelch threshold (aui_rd±)	—	175	275	mV
$V_{asq}^{-1}$	Differential negative squelch threshold (aui_rd± and aui_cd±)	—	-275	-175	mV
$V_{odu}^1$	Transmit differential output undershoot voltage on return to zero (aui_td±)	78 $\Omega$ termination	—	-100	mV
<b>Twisted-Pair Interface Pins</b>					
$V_{toh}$	Output high voltage (tp_td± and tp_td±±)	$I_{oh} = -25$ mA	2.5	—	V
$V_{tol}$	Output low voltage (tp_td± and tp_td±±)	$I_{ol} = 25$ mA	—	0.5	V
$V_{tsq}^{+1}$	Differential positive squelch threshold (tp_rd±)	—	300	520	mV
$V_{tsq}^{-1}$	Differential negative squelch threshold (tp_rd±)	—	-520	-300	mV
$V_{tdif}^1$	Differential input voltage range (tp_rd±)	—	-3.1	3.1	V

<sup>1</sup>. Parameter design guarantee.

## 3.6 Serial Interface Attachment Specifications

This section describes the dc specifications and timing limits of the SIA unit.

### 3.6.1 Serial Clock Timing

Figure 6 shows the serial clock (TTL or CMOS) timing characteristics, and Table 20 lists the serial clock timing specifications.

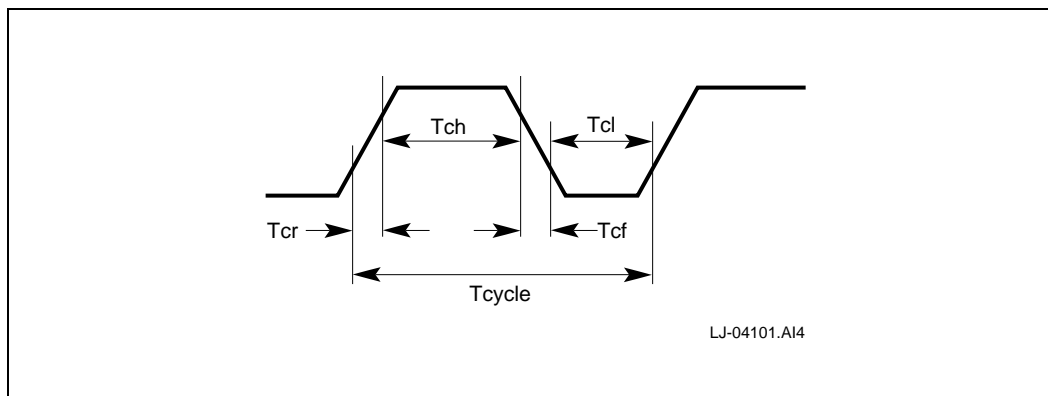

Figure 6. Serial Clock (XTAL) Timing Diagram

Table 20. Serial Clock (XTAL) Timing Specifications

Symbol	Parameter	Minimum	Maximum
$T_{cr}^1$	Rise time	—	4 ns
$T_{cf}^1$	Fall time	—	4 ns
$T_{cycle}^1$	Cycle time	49.995 ns	50.005 ns
Tch	Clock high time	$0.4 \cdot T_{cycle}$	$0.6 \cdot T_{cycle}$
Tcl	Clock low time	$0.4 \cdot T_{cycle}$	$0.6 \cdot T_{cycle}$

<sup>1</sup>. Parameter design guarantee.

### 3.6.2 Internal SIA Mode AUI Timing—Transmit

Figure 7 shows the internal SIA transmit timing characteristics for the AUI, and Table 21 lists the internal SIA transmit timing limits for the AUI.

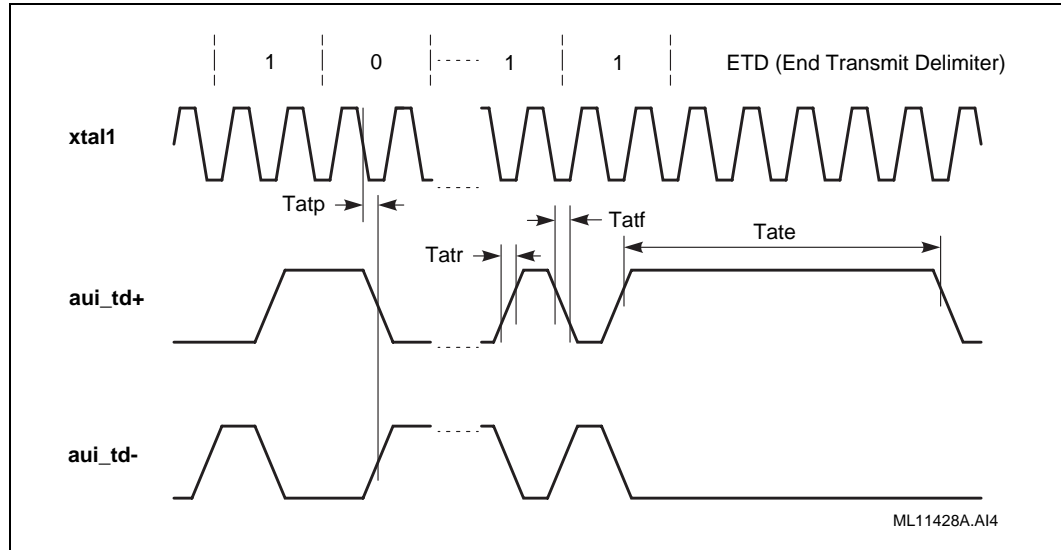

Figure 7. Internal SIA Mode AUI Timing Diagram—Transmit

Table 21. Internal SIA Mode AUI Timing Specifications—Transmit

Symbol	Definition	Minimum	Maximum	Unit
Tatp	aui_td+, aui_td- propagation delay from xtal1 fall	—	30	ns
Tatr <sup>1</sup>	aui_td+, aui_td- rise time	2	8	ns
Tatf <sup>1</sup>	aui_td+, aui_td- fall time	2	8	ns
Tatm <sup>1</sup>	aui_td+, aui_td- rise and fall time mismatch (not shown)	—	1	ns
Tate <sup>1</sup>	aui_td± end transmit delimiter length	345	405	ns

<sup>1</sup>. Parameter design guarantee.

### 3.6.3 Internal SIA Mode AUI Timing—Receive

Figure 8 shows the internal SIA receive timing characteristics for the AUI, and Table 22 lists the internal SIA receive timing limits for the AUI.

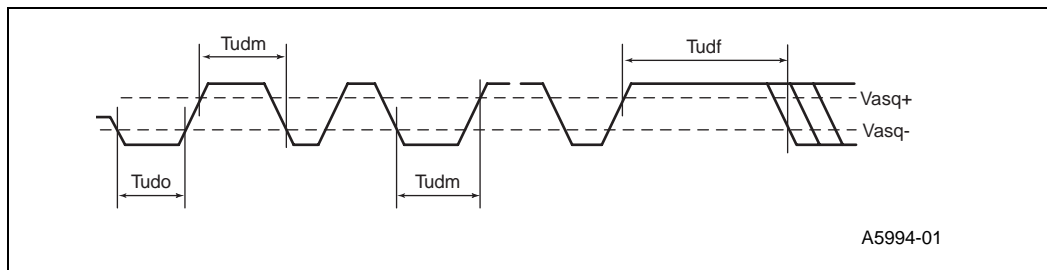

Figure 8. Internal SIA Mode AUI Timing Diagram—Receive

### 3.6.4 Internal SIA Mode AUI Timing—Collision

Figure 9 shows the internal SIA collision timing characteristics for the AUI, and Table 22 lists the internal SIA collision timing limits for the AUI.

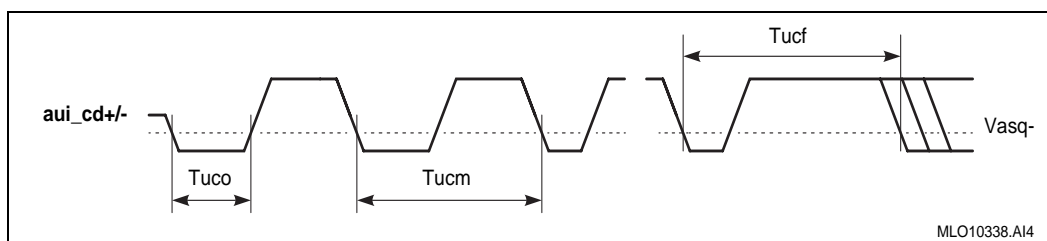

Figure 9. Internal SIA Mode AUI Timing Diagram—Collision

Table 22. Internal SIA Mode AUI Timing Specifications—Receive and Collision

Symbol	Definition	Minimum	Maximum	Unit
Tудо	aui_rd± start of frame pulse width	15	20	ns
Tудм <sup>1</sup>	aui_rd± delay between opposite squelch crossings not recognized as end of packet	—	140	ns
Tудф <sup>1</sup>	aui_rd± delay from last squelch crossing recognized as end of packet	150	—	ns
Tусо	aui_cd± start of collision pulse width	20	25	ns
Tусм <sup>1</sup>	aui_cd± delay between squelch crossings not recognized as end of collision	—	140	ns
Tуцф <sup>1</sup>	aui_cd± delay from last squelch crossing recognized as end of collision	150	—	ns

<sup>1</sup>. Parameter design guarantee.



### 3.6.5 Internal SIA Mode 10BASE-T Interface Timing—Transmit

Figure 10 shows the internal SIA transmit timing characteristics for the 10BASE-T interface, and Table 23 lists the internal SIA transmit limits.

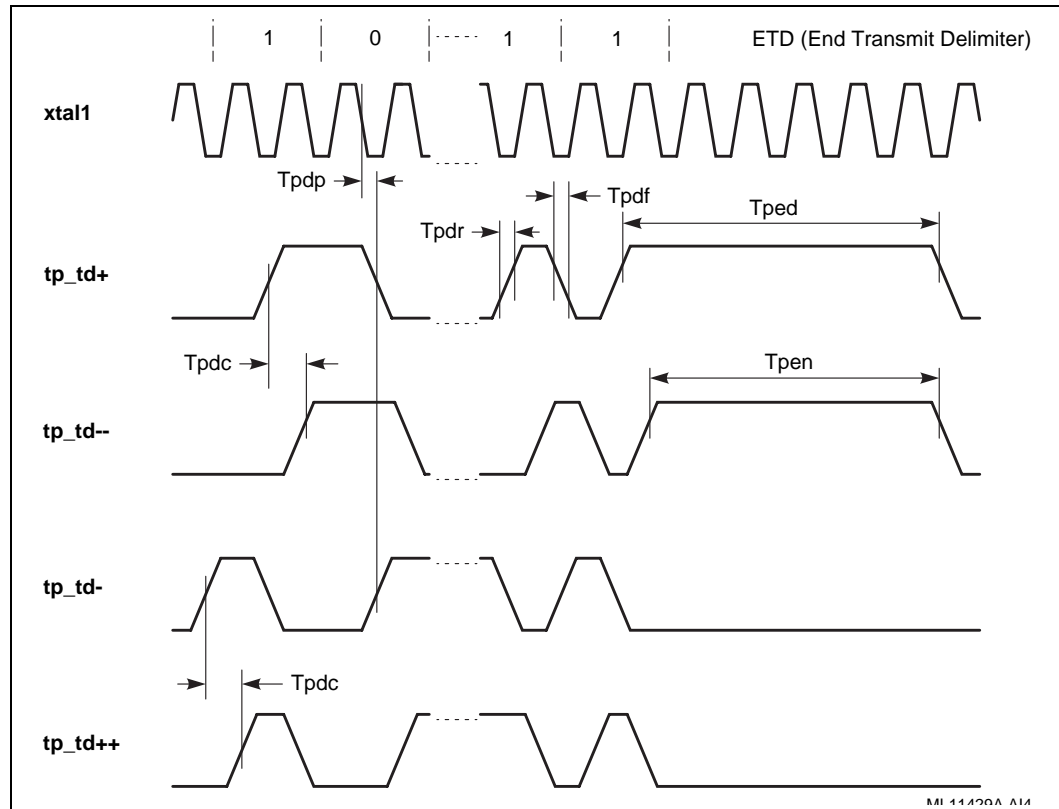

Figure 10. Internal SIA Mode 10BASE-T Interface Timing Diagram—Transmit

Table 23. Internal SIA Mode 10BASE-T Interface Timing Specifications—Transmit

Symbol	Definition	Minimum	Maximum	Unit
$T_{pdp}$	$tp\_td+$ , $tp\_td-$ propagation delay from $xtal1$ fall	—	30	ns
$T_{pdr}^1$	$tp\_td+$ , $tp\_td++$ , $tp\_td-$ , $tp\_td-$ – rise time	2	8	ns
$T_{pdf}^1$	$tp\_td+$ , $tp\_td++$ , $tp\_td-$ , $tp\_td-$ – fall time	2	8	ns
$T_{pdm}^1$	$tp\_td+$ , $tp\_td++$ , $tp\_td-$ , $tp\_td-$ – rise and fall time mismatch (not shown)	—	1	ns
$T_{pdc}^1$	$tp\_td+$ to $tp\_td-$ – and $tp\_td-$ to $tp\_td++$ delay	46	54	ns
$T_{ped}^1$	$tp\_td\pm$ end transmit delimiter length	295	355	ns
$T_{pen}^1$	$tp\_td++/-$ – end transmit delimiter length	245	305	ns

<sup>1</sup>: Parameter design guarantee.

### 3.6.6 Internal SIA Mode 10BASE-T Interface Timing—Receive

Figure 11 shows the internal SIA receive timing characteristics for the 10BASE-T interface, and Table 24 lists the internal SIA receive limits for the 10BASE-T interface.

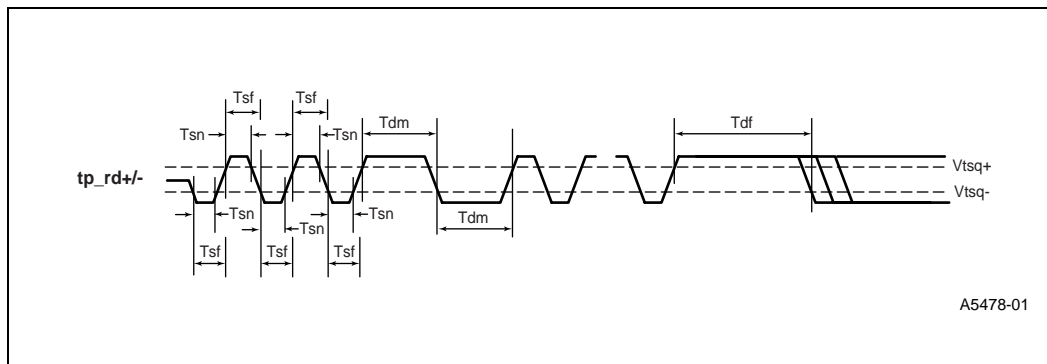

Figure 11. Internal SIA Mode 10BASE-T Interface Timing Diagram—Receive

Table 24. Internal SIA Mode 10BASE-T Interface Timing Specifications—Receive

Symbol	Definition	Minimum	Maximum	Unit
Tsn <sup>1</sup>	tp_rd± start of frame pulse width during smart squelch operation	15	20	ns
Tsf <sup>1</sup>	tp_rd± maximum delay between opposite squelch crossings not to turn smart squelch off	140	150	ns
Tdm <sup>1</sup>	tp_rd± delay between opposite squelch crossings not recognized as end of packet	—	140	ns
Tdf <sup>1</sup>	tp_rd± delay from last squelch crossing recognized as end of packet	150	—	ns

<sup>1</sup>. Parameter design guarantee.

### 3.6.7 Internal SIA Mode 10BASE-T Interface Timing—Idle Link Pulse

Figure 12 shows the internal SIA idle link pulse timing characteristics for the 10BASE-T interface, and Table 25 lists the internal SIA idle link pulse limits for the 10BASE-T interface.

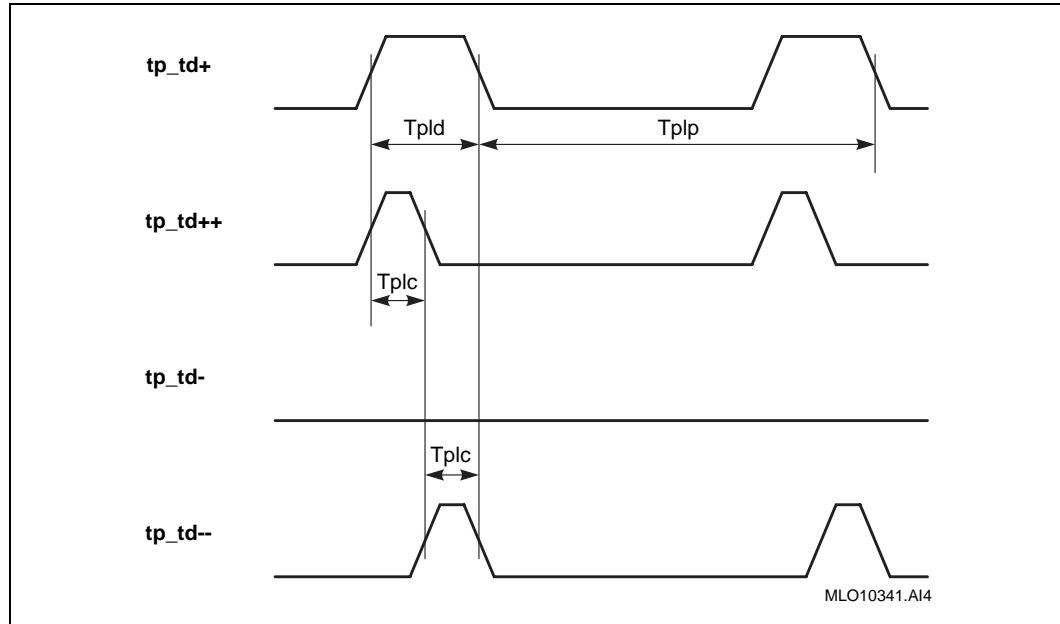

Figure 12. Internal SIA Mode 10BASE-T Interface Timing Diagram—Idle Link Pulse

Table 25. Internal SIA Mode 10BASE-T Interface Timing Specifications—Idle Link Pulse

Symbol	Definition	Minimum	Maximum	Unit
Tpld <sup>1</sup>	tp_td+ idle link pulse width	80	120	ns
Tplc <sup>1</sup>	tp_td++ and tp_td-- idle link pulse width	40	60	ns
Tplp <sup>1</sup>	Idle link pulse period	8	24	ms

<sup>1</sup>. Parameter design guarantee.

## 3.7 MII Interface Specifications

Table 26 lists the specifications for the MII interface.

**Table 26. MII Interface**

Symbol	Definition	Condition	Minimum	Maximum	Unit
$V_{oh}$	Output high voltage	$I_{oh} = -4 \text{ mA}$	2.4	—	V
$V_{ol}$	Output low voltage	$I_{ol} = 4 \text{ mA}$	—	0.4	V
$V_{ih}$	Input high voltage	—	2.0	—	V
$V_{il}$	Input low voltage	—	—	0.8	V
$I_{in}$	Input current	$V_{in} = vcc \text{ or } vss$	-10.0	10.0	$\mu\text{A}$
$I_{oz}$	Maximum tristate output leakage current	$V_{in} = vdd \text{ or } vss$	-10.0	10.0	$\mu\text{A}$

## 3.8 MII/SYM Port Timing

This section describes the MII/SYM port timing limits.

### 3.8.1 MII/SYM 10/100-Mb/s and 10-Mb/s Timing—Transmit

Figure 13 shows the MII/SYM port transmit timing characteristics, and Table 27 lists the MII/SYM port transmit timing limits.

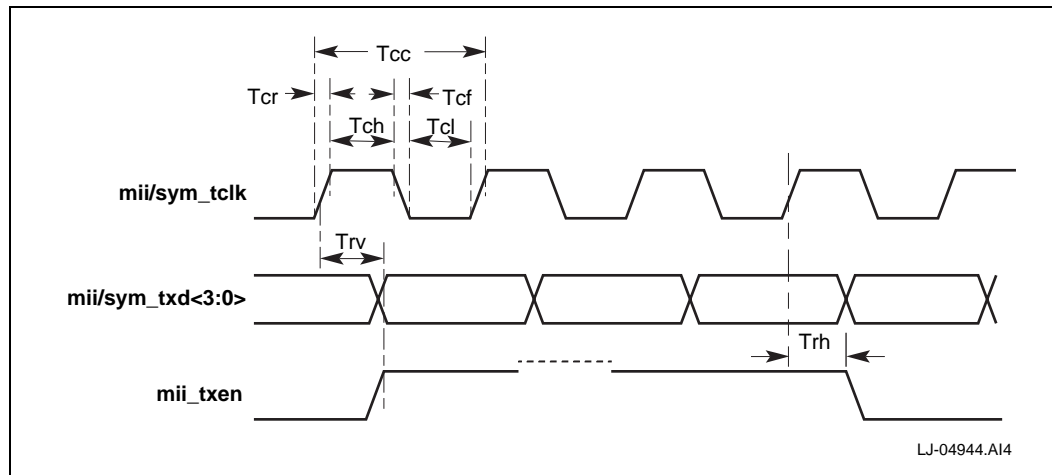

Figure 13. MII/SYM Port Timing Diagram—Transmit

Table 27. MII/SYM Port Timing Limits—Transmit

Symbol	Definition	Minimum	Typical	Maximum	Unit
Tcc <sup>1</sup>	mii/sym_tclk cycle	—	40t <sup>2</sup>	—	ns
Tch	mii/sym_tclk high time	14t <sup>2</sup>	—	26t <sup>2</sup>	ns
Tcl	mii/sym_tclk low time	14t <sup>2</sup>	—	26t <sup>2</sup>	ns
Tcr <sup>3</sup>	mii/sym_tclk rise time	—	8	—	ns
Tcf <sup>3</sup>	mii/sym_tclk fall time	—	8	—	ns
Trv <sup>4</sup>	mii_tclk rise to mii_txen valid time or mii/sym_tclk rise to mii/sym_txd valid time	—	—	20	ns
Trh	mii_txen hold after mii_tclk rise time	5	—	—	ns

<sup>1</sup>. ±50 parts per million.

<sup>2</sup>. t=1 for 100-Mb/s operation; t=10 for 10-Mb/s operation.

<sup>3</sup>. Parameter design guarantee.

<sup>4</sup>. The transmit data (mii/sym\_txd) and transmit enable (mii\_txen) output pins are driven internally from the rising edge of mii/sym\_tclk.

### 3.8.2 MII/SYM 10/100-Mb/s Timing—Receive

Figure 14 shows the MII/SYM port receive timing characteristics, and Table 28 lists the MII/SYM port receive timing limits.

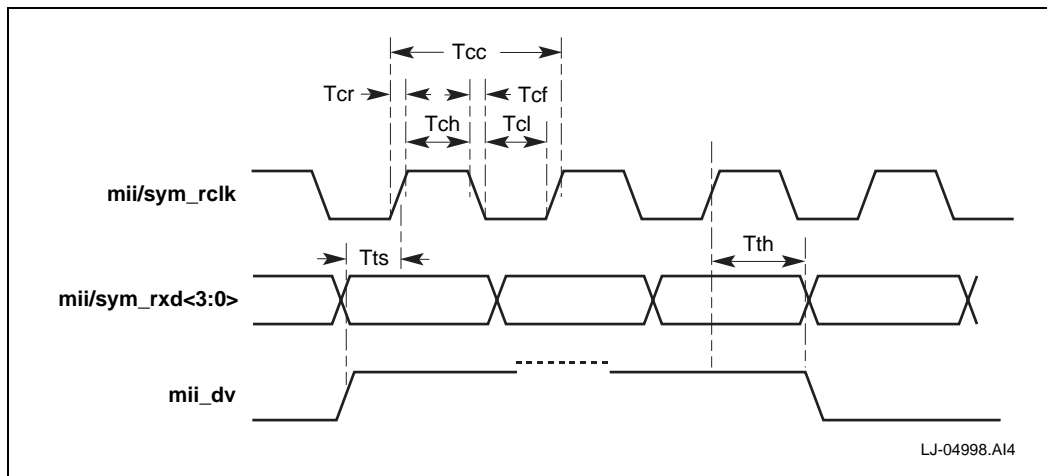

Figure 14. MII/SYM Port Timing Diagram—Receive

Table 28. MII/SYM Port Timing Limits—Receive

Symbol	Definition	Minimum	Typical	Maximum	Unit
Tcc <sup>1</sup>	mii/sym_rclk cycle time	—	40t <sup>2</sup>	—	ns
Tc	mii/sym_rclk high time	14t <sup>2</sup>	—	26t <sup>2</sup>	ns
Tcl	mii/sym_rclk low time	14t <sup>2</sup>	—	26t <sup>2</sup>	ns
Tcr <sup>3</sup>	mii/sym_rclk rise time	—	8	—	ns
Tcf <sup>3</sup>	mii/sym_rclk fall time	—	8	—	ns
Tts <sup>4</sup>	mii/sym_rxd setup (both rise and fall transactions) to mii/sym_rclk rise time or mii_dv setup (both rise and fall transactions) to mii_rclk rise time	8	—	—	ns
Tth	mii/sym_rxd hold (both rise and fall transactions) after mii/sym_rclk rise time or mii_dv hold (both rise and fall transactions) after mii_rclk rise time	10	—	—	ns

1. ±50 parts per million.

2. t=1 for 100-Mb/s operation; t=10 for 10-Mb/s operation.

3. Parameter design guarantee.

4. The receive data (mii/sym\_rxd) and data valid (mii\_dv) input pins are latched internally on the rising edge of mii/sym\_rclk.

### 3.8.3 SYM 10/100-Mb/s Timing—Signal Detect

Figure 15 shows the SYM port signal detect timing characteristics, and Table 29 lists the SYM port signal detect timing limits.

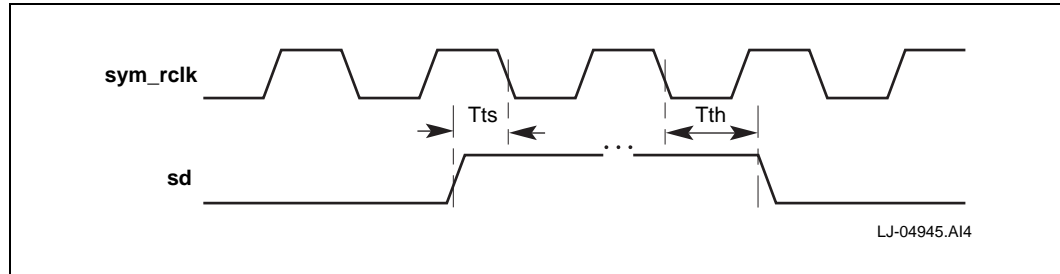

Figure 15. SYM Port Timing Diagram—Signal Detect

Table 29. SYM Port Timing Limits—Signal Detect

Symbol	Definition	Minimum	Maximum	Units
Tts <sup>1</sup>	sd setup (both rise and fall transactions) to sym_rclk fall time	10	—	ns
Tth <sup>1</sup>	sd hold (both rise and fall transactions) after sym_rclk fall time	12	—	ns

<sup>1</sup>. Input signal detect (sd) is latched internally on the falling edge of sym\_rclk.

### 3.8.4 MII 10/100-Mb/s Timing—Receive Error

Figure 16 shows the MII port receive error timing characteristics, and Table 30 lists the MII port receive error timing limits.

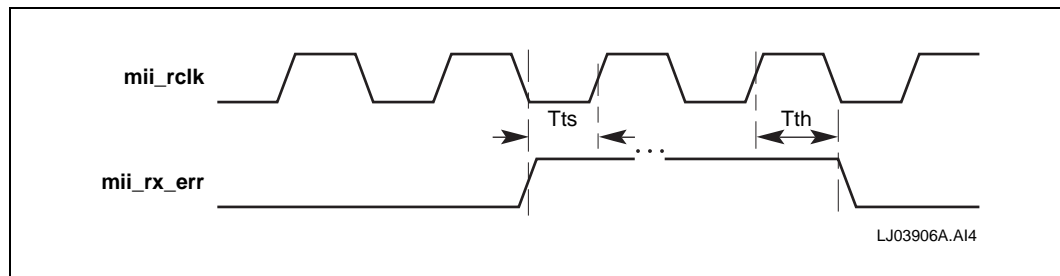

Figure 16. MII Port Timing Diagram—Receive Error

Table 30. MII Port Timing Limits—Receive Error

Symbol	Definition	Minimum	Maximum	Unit
Tts <sup>1</sup>	mii_rx_err setup (both rise and fall transactions) to mii_rclk rise time	10	—	ns
Tth <sup>1</sup>	mii_rx_err hold (both rise and fall transactions) after mii_rclk rise time	10	—	ns

<sup>1</sup>. Input signal detect (mii\_rx\_err) is latched internally on the falling edge of mii\_rclk.

### 3.8.5 MII 10/100-Mb/s Timing—Carrier Sense and Collision

Figure 17 shows the MII port carrier sense and collision timing characteristics, and Table 31 lists the MII port carrier sense and collision timing limits.

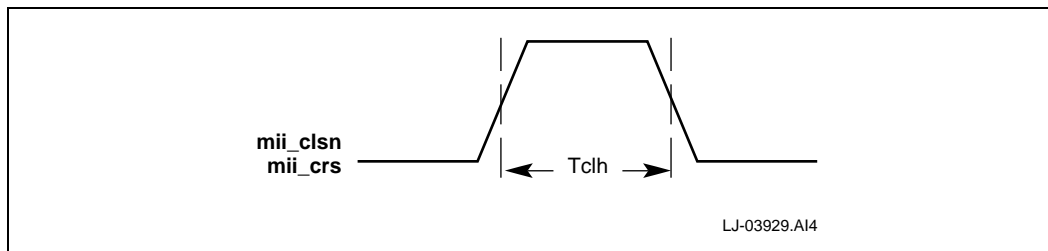

Figure 17. MII Port Timing Diagram—Carrier Sense and Collision

Table 31. MII Port Timing Limits—Carrier Sense and Collision

Symbol	Definition	Minimum	Maximum	Unit
Tchl	mii_crs, mii_clsn high time	20	—	ns

## 3.9 Boot ROM and Serial ROM Port Specification

Table 32 lists the dc specifications for the boot ROM and serial ROM ports. These specifications apply in any mode in which the ports are used.

Table 32. Boot ROM and Serial ROM Port DC Specifications

Symbol	Definition	Condition	Minimum	Maximum	Unit
$V_{oh}$	Output high voltage	$I_{oh} = -4 \text{ mA}$	2.4	—	V
$V_{ol}$	Output low voltage	$I_{ol} = 4 \text{ mA}$	—	0.4	V
$V_{ih}$	Input high voltage	—	2.0	—	V
$V_{il}$	Input low voltage	—	—	0.8	V
$I_{oz}^1$	Maximum tristate output leakage current	$V_{out} = vdd \text{ or } vss$	-10	10	$\mu\text{A}$

<sup>1</sup> For sr\_do and br\_ce\_l, the maximum value is 1000.0 mA.



### 3.10 Boot ROM Port Timing

This section describes the boot ROM port timing.

#### 3.10.1 Boot ROM Read Timing

Figure 18 shows the boot ROM read timing characteristics, and Table 33 lists the boot ROM read timing limits.

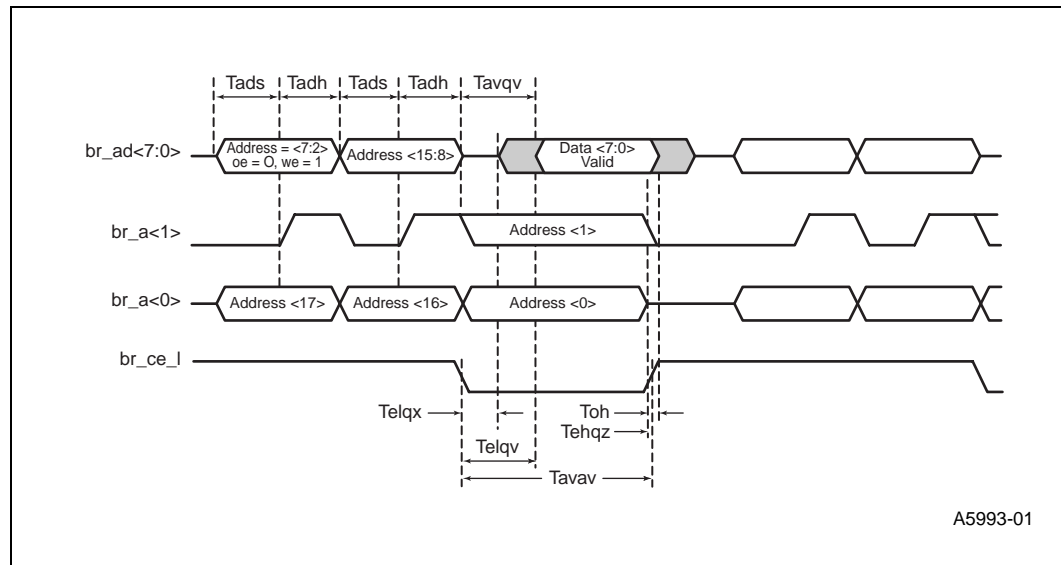

Figure 18. Boot ROM Read Timing Diagram

Table 33. Boot ROM Read Timing Specifications

Symbol	Parameter	Minimum	Maximum	Unit
Tavav	Read cycle time	240	—	ns
Tavqv	Address to output delay	—	240	ns
Telqv	br_ce_l to output delay	—	240	ns
Telqx <sup>1</sup>	br_ce_l to output low impedance	0	—	ns
Tehqz <sup>1</sup>	br_ce_l going high to output high impedance	—	55	ns
Toh	Output hold from br_ce_l change	0	—	ns
Tads	Address setup to latch enable high	30	—	ns
Tadh	Address hold from latch enable high	30	—	ns

<sup>1</sup>: Parameter design guarantee.



### 3.11 Serial ROM Port Timing

Figure 20 shows the serial ROM port timing, and Table 35 lists the characteristics. This timing is identical to the timing for the MII management signals (mii\_mdio and mii\_mdc).

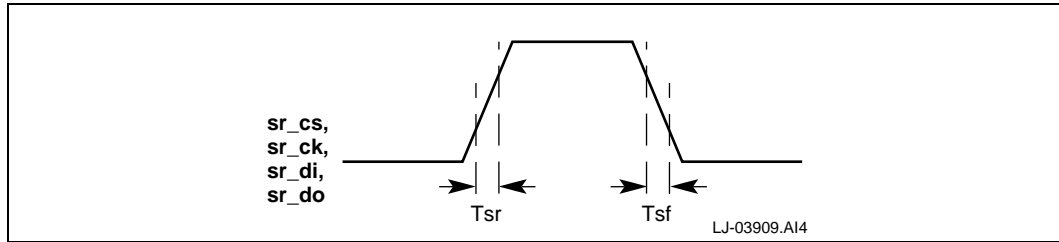

Figure 20. Serial ROM Port Timing Diagram

Table 35. Serial ROM Port Timing Characteristics

Symbol	Definition	Minimum	Maximum	Unit
Tsr <sup>1</sup>	Rise time	—	10	ns
Tsf <sup>1</sup>	Fall time	—	10	ns

<sup>1</sup>. Parameter design guarantee.

### 3.12 External Register Timing

Figure 21 shows the external register read timing characteristics, and Figure 22 shows the write timing characteristics. Table 36 lists the external register timing specifications for both read and write operations.

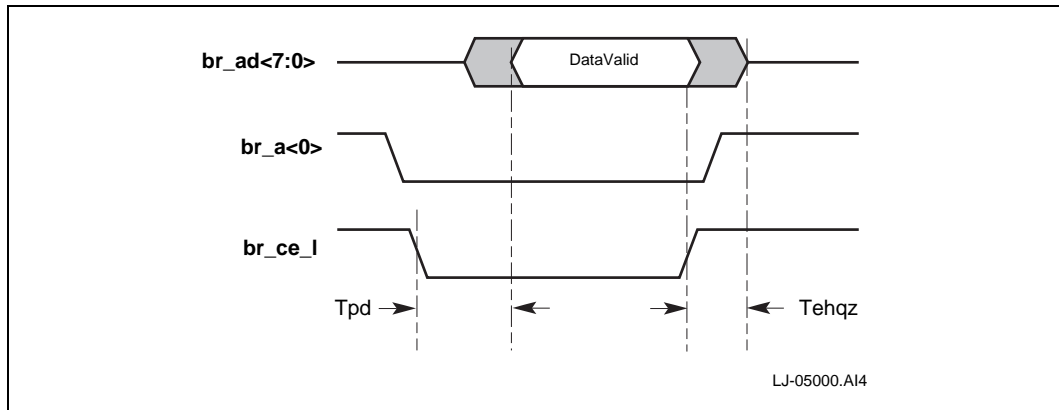

Figure 21. External Register Read Timing Diagram

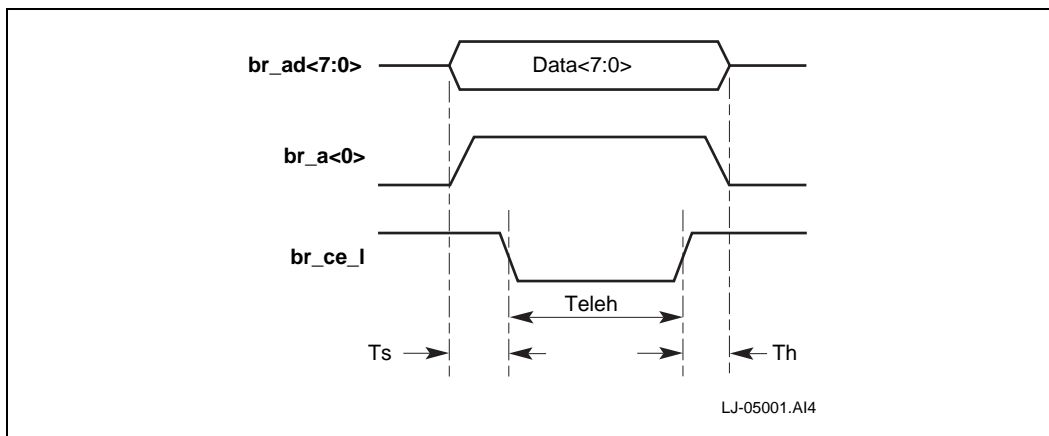

Figure 22. External Register Write Timing Diagram

Table 36. External Register Timing Specifications

Symbol	Parameter	Minimum	Maximum	Unit
Teleh	br_ce_l pulse width	240	—	ns
Read Timing				
Tpd	br_ce_l low to br_ad<7:0> valid high	—	20	ns
Tehqz <sup>1</sup>	br_ce_l high to br_ad<7:0> high impedance	—	20	ns
Write Timing				
Ts	Data setup time prior to br_ce_l	30	—	ns
Th	Data hold after br_ce_l high	30	—	ns

<sup>1</sup>. Parameter design guarantee.

### 3.13 Joint Test Action Group—Test Access Port

This section provides the joint test action group (JTAG) test access port specifications.

#### 3.13.1 JTAG DC Specifications

Table 37 lists the dc specifications for the JTAG pins

**Table 37. JTAG DC Specifications**

Symbol	Definition	Condition	Minimum	Maximum	Unit
$V_{oh}$	Output high voltage	$I_{oh} = -4 \text{ mA}$	2.4	—	V
$V_{ol}$	Output low voltage	$I_{ol} = 4 \text{ mA}$	—	0.4	V
$V_{ih}$	Input high voltage	—	2.0	—	V
$V_{il}$	Input low voltage	—	—	0.8	V
$I_{ip}$	Input leakage current on pins with internal pull-ups (tdi and tms)	$0.0 < V_{in} < v_{dd}$	—	+20/–1000 <sup>1</sup>	$\mu\text{A}$
$I_{oz}$	Tristate output leakage current (tdo)	$0.0 < V_{out} < v_{dd}$	—	$\pm 20$	$\mu\text{A}$

<sup>1</sup>. For pins tdi and tms that have internal pull-ups, the leakage current can get to 1.0 mA when  $V_{in} = 0 \text{ V}$ .

### 3.13.2 JTAG Boundary-Scan Timing

Figure 23 shows the JTAG boundary-scan timing, and Table 38 lists the interface signal timing relationships.

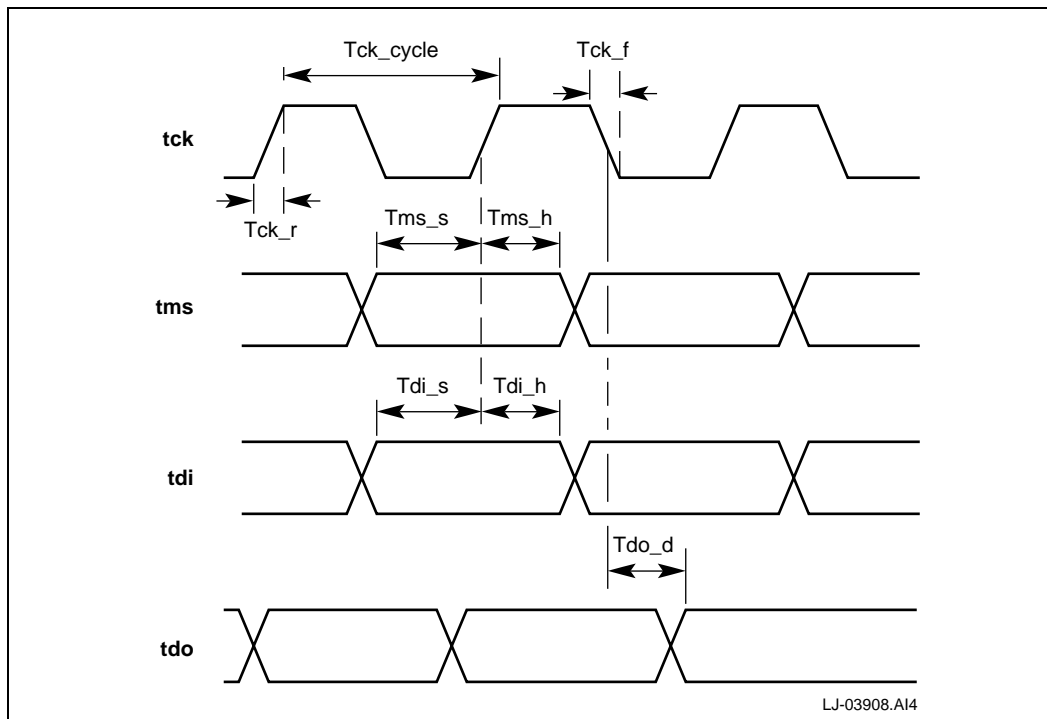

Figure 23. JTAG Boundary-Scan Timing Diagram

Table 38. JTAG Interface Signal Timing Relationships

Symbol	Parameter	Minimum	Maximum	Unit
Tms_s	tms setup time	20	—	ns
Tms_h	tms hold time	5	—	ns
Tdi_s	tdi setup time	20	—	ns
Tdi_h	tdi hold time	5	—	ns
Tdo_d	tdo delay time	—	20	ns
Tck_r <sup>1</sup>	tck rise time	—	3	ns
Tck_f <sup>1</sup>	tck fall time	—	3	ns
Tck_cycle	tck cycle time	90	—	ns

<sup>1</sup>. Parameter design guarantee.

## 4.0 Mechanical Specifications

---

The 21143 is contained in either a 144-pin LQFP package type or a 144-pin MQFP package type.

Figure 24 shows the mechanical layout of the LQFP, and Table 39 lists the LQFP package dimensions in millimeters.

Figure 25 shows the mechanical layout of the MQFP, and Table 40 lists the MQFP package dimensions in millimeters.

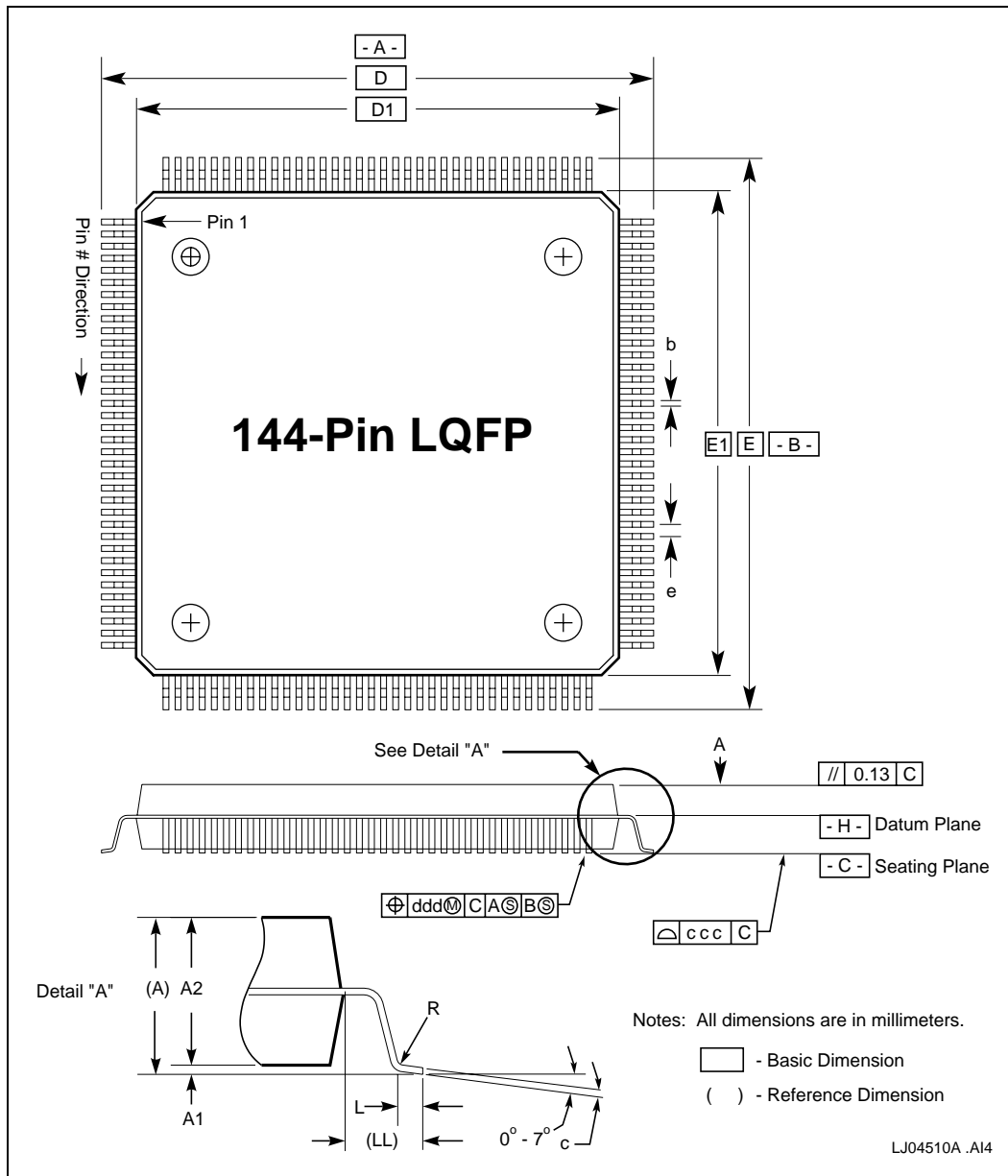

Figure 24. 144-Pin LQFP Package



**Table 39. 144-Pin LQFP Package Dimensions**

Symbol	Dimension	Value (mm)
LL	Lead length	1.00 reference <sup>1</sup>
e	Lead pitch	0.50 BSC <sup>2</sup>
L	Foot length	0.45 minimum to 0.75 maximum
A	Package overall height	1.60 maximum
A1	Package standoff height	0.05 minimum
A2	Package thickness	1.35 minimum to 1.45 maximum
b	Lead width	0.17 minimum to 0.27 maximum
c	Lead thickness	0.09 minimum to 0.20 maximum
ccc	Coplanarity	0.08
ddd	Lead skew	0.08
D	Package overall width	22.00 BSC
D1	Package width	20.00 BSC
E	Package overall length	22.00 BSC
E1	Package length	20.00 BSC
R	Ankle radius	0.08 minimum to 0.20 maximum

<sup>1</sup>. The value for this measurement is for reference only.  
<sup>2</sup>. ANSI Y14.5M–1982 American National Standard Dimensioning and Tolerancing, Section 1.3.2, defines Basic Dimension (BSC) as: A numerical value used to describe the theoretically exact size, profile, orientation, or location of a feature or datum target. It is the basis from which permissible variations are established by tolerances on other dimensions, in notes, or in feature control frames.

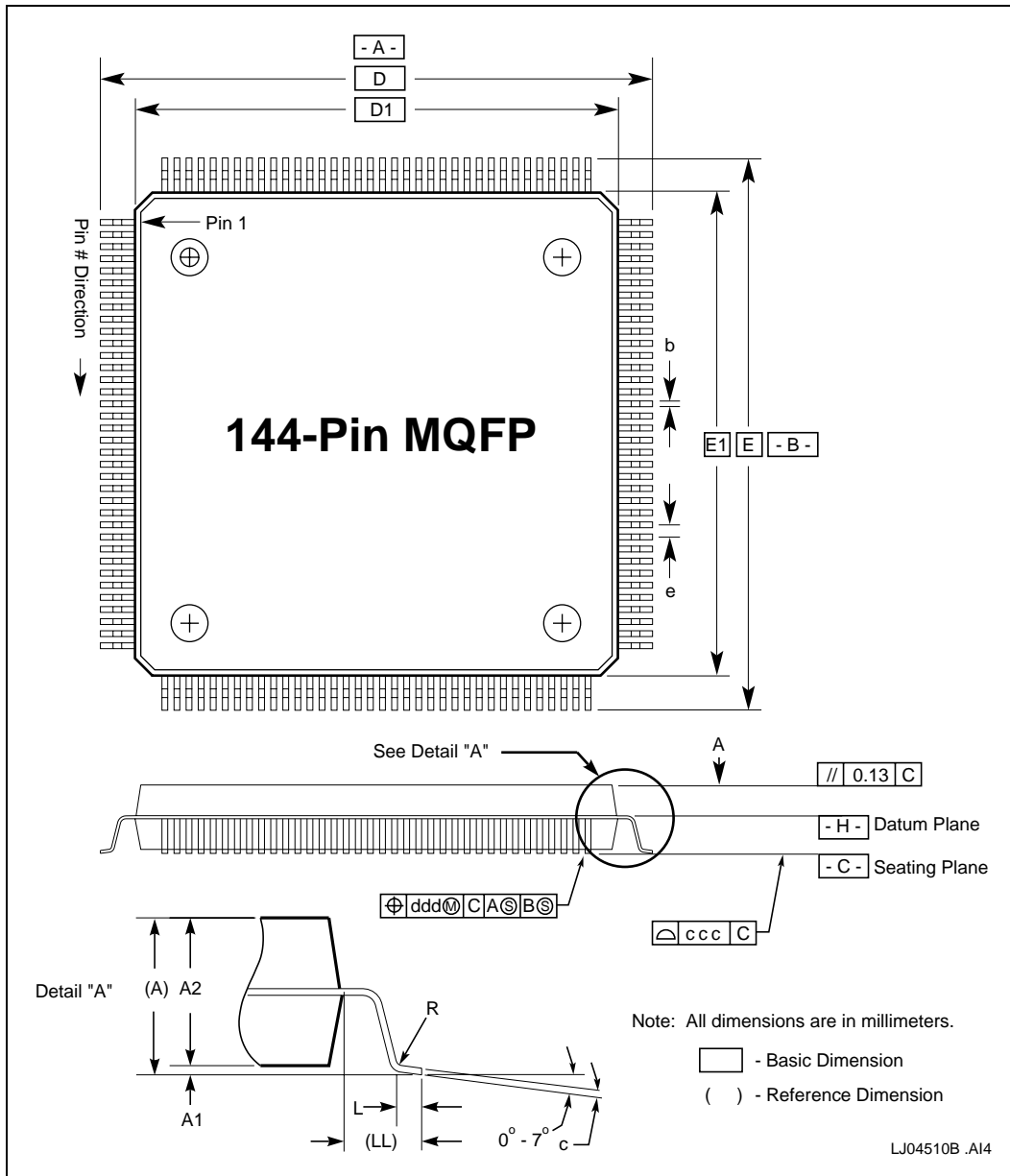

Figure 25. 144-Pin MQFP Package

**Table 40. 144-Pin MQFP Package Dimensions**

Symbol	Dimension	Value (mm)
LL	Lead length	1.60 reference <sup>1</sup>
e	Lead pitch	0.65 BSC <sup>2</sup>
L	Foot length	0.65 minimum to 1.03 maximum
A	Package overall height	4.1 maximum
A1	Package standoff height	0.25 minimum
A2	Package thickness	3.20 minimum to 3.60 maximum
b	Lead width	0.22 minimum to 0.40 maximum
c	Lead thickness	0.11 minimum to 0.23 maximum
ccc	Coplanarity	0.10
ddd	Lead skew	0.13
D	Package overall width	31.20 BSC
D1	Package width	28.00 BSC
E	Package overall length	31.20 BSC
E1	Package length	28.00 BSC
R	Ankle radius	0.13 minimum to 0.30 maximum

<sup>1</sup>. The value for this measurement is for reference only.  
<sup>2</sup>. ANSI Y14.5M–1982 American National Standard Dimensioning and Tolerancing, Section 1.3.2, defines Basic Dimension (BSC) as: A numerical value used to describe the theoretically exact size, profile, orientation, or location of a feature or datum target. It is the basis from which permissible variations are established by tolerances on other dimensions, in notes, or in feature control frames.



# Support, Products, and Documentation

---

If you need technical support, a *Product Catalog*, or help deciding which documentation best meets your needs, visit the Intel World Wide Web Internet site:

<http://www.intel.com>

Copies of documents that have an ordering number and are referenced in this document, or other Intel literature may be obtained by calling **1-800-332-2717** or by visiting Intel's website for developers at:

<http://developer.intel.com>

You can also contact the Intel Massachusetts Information Line or the Intel Massachusetts Customer Technology Center. Please use the following information lines for support:

For Documentation and General Information	
Intel Massachusetts Information Line	
United States:	1-800-332-2717
Outside United States:	1-303-675-2148
Electronic mail address:	techdoc@intel.com

For Technical Support	
Intel Massachusetts Customer Technology Center	
Phone (U.S. and international):	1-978-568-7474
Fax:	1-978-568-6698
Electronic mail address:	techsup@intel.com