

SB820 THRU SB8100



8.0 AMP SCHOTTKY BARRIER RECTIFIERS



FEATURES

- * Low forward voltage drop
- * High current capability
- * High reliability
- * High surge current capability
- * Epitaxial construction

MECHANICAL DATA

- * Case: Molded plastic
- * Epoxy: UL 94V-0 rate flame retardant
- * Lead: Lead solderable per MIL-STD-202, method 208 guaranteed
- * Polarity: As Marked
- * Mounting position: Any
- * Weight: 2.24 grams
- * Both normal and Pb free product are available:
- * Normal: 80~95%Sn, 5~20%Pb
- * Pb free: 99 Sn above can meet Rohs environment substance directive request

VOLTAGE RANGE

20 to 100 Volts

CURRENT

8.0 Amperes

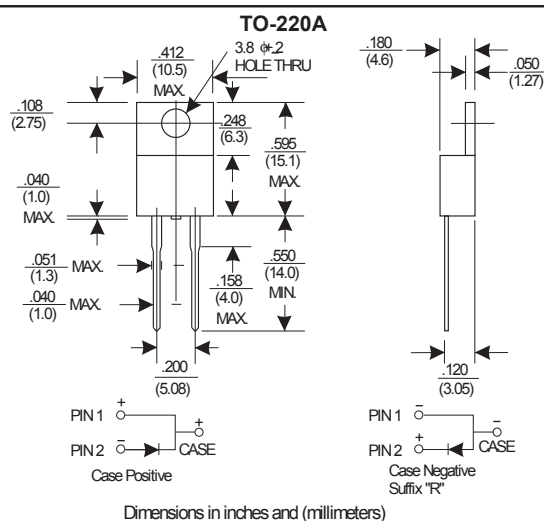

MAXIMUM RATINGS AND ELECTRICAL CHARACTERISTICS

Rating 25°C ambient temperature unless otherwise specified.
Single phase half wave, 60-Hz, resistive or inductive load.
For capacitive load, derate current by 20%.

TYPE NUMBER	SB820	SB830	SB840	SB850	SB860	SB880	SB8100	UNITS
Maximum Recurrent Peak Reverse Voltage	20	30	40	50	60	80	100	V
Maximum RMS Voltage	14	21	28	35	42	49	56	V
Maximum DC Blocking Voltage	20	30	40	50	60	80	100	V
Maximum Average Forward Rectified Current								A
See Fig. 1	8.0							A
Peak Forward Surge Current, 8.3 ms single half sine-wave superimposed on rated load (JEDEC method)	150							A
Maximum Instantaneous Forward Voltage at 8.0A	0.65		0.75					V
Maximum DC Reverse Current at Rated DC Blocking Voltage	Ta=25 C			Ta=100 C				mA
Typical Junction Capacitance (Note 1)	700			460				pF
Typical Thermal Resistance R _{θJC} (Note 2)	3.0							°C/W
Operating Temperature Range T _J	-65—+125			-65—+150				°C
Storage Temperature Range T _{STG}	-65—+150							°C

NOTES:

1. Measured at 1MHz and applied reverse voltage of 4.0V D.C.
2. Thermal Resistance Junction to Case.

RATING AND CHARACTERISTIC CURVES (SB820 THRU SB100)

FIG.1-TYPICAL FORWARD CURRENT DERATING CURVE

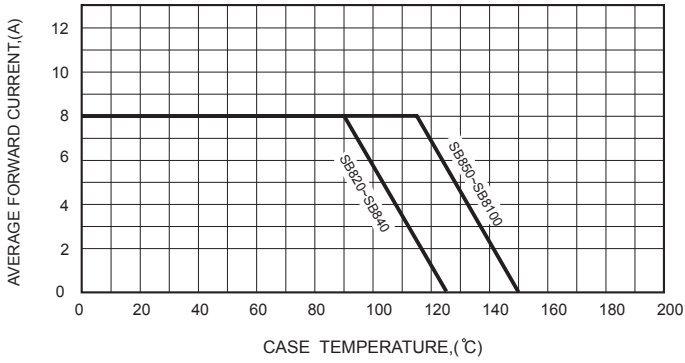

FIG.2-TYPICAL FORWARD CHARACTERISTICS

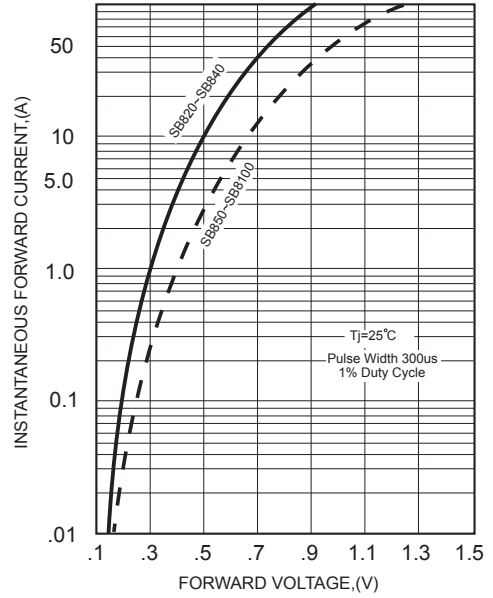

FIG.3-MAXIMUM NON-REPETITIVE FORWARD SURGE CURRENT

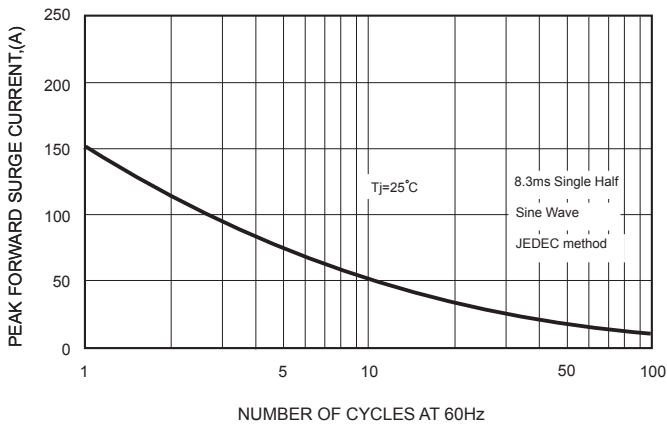

FIG.5 - TYPICAL REVERSE CHARACTERISTICS

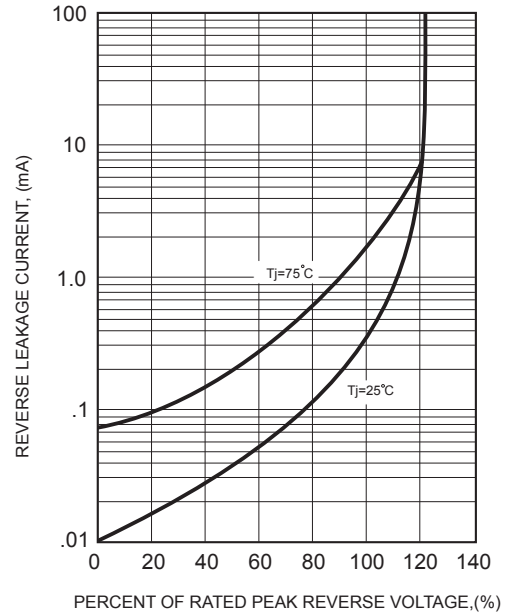

FIG.4-TYPICAL JUNCTION CAPACITANCE

